

DELHI

COLLEGE OF

ENGINEERING



**LIBRARY**

**Kashmiri Gate, Delhi-110006**

Accession No.

14947

Class No.

669

Book No.

SAM

# DELHI COLLEGE OF ENGINEERING

Kashmere Gate, Delhi

## LIBRARY

### DATE DUE

For each day's delay after the due date a fine of 10 P. per Vol. shall be charged for the first week, and 50 P. per Vol. per day for subsequent days. Text Book Re. 1.00.

Borrower's No.	Date Due	Borrower's No.	Date Due
<del>239/93</del>	<del>28 DEC 1996</del>	<del>2</del>	
<del>80/99</del>	<del>0 MAY 1997</del>	<del>1</del>	
<del>97/0-719</del>	<del>0 SEP 1999</del>	<del>11</del>	
<del>58/2</del>	<del>4 JAN 2004</del>	<del>R</del>	
08 SE	2001		
05 OCT	2006		
	2006		



**CARL H. SAMANS, PH.D.**  
*Chief, Metallurgy Section, Research Laboratory,  
American Optical Company*

**Engineering Metals  
and Their Alloys**

*New York* THE MACMILLAN COMPANY 1949

COPYRIGHT, 1949, BY THE MACMILLAN COMPANY

All rights reserved—no part of this book may be reproduced in any form without permission in writing from the publisher, except by a reviewer who wishes to quote brief passages in connection with a review written for inclusion in magazine or newspaper.

PRINTED IN THE UNITED STATES OF AMERICA

*Many of the alloys discussed in this book bear trade marked names, and United States or foreign patents frequently cover either the compositions, the processes of fabrication, or the methods of heat treatment used with them. The fact that these patents are or are not specifically mentioned is not to be construed in any way as granting or implying any rights or permissions under them.*

Dedicated to my father, Walter Samans,

who as an engineer had to use metals  
and wanted to know more about them,

and to those who bear his name:  
my brother, son and two nephews,

who may, in time, want to know more about these materials  
which they, too, will have to use.



## Preface

**T**HIS TEXT GIVES A BACKGROUND OF METALLURGY WHICH should fill the needs of any user of the metallic materials. It is inevitable that, even with a limited treatment of these materials, the book will be large. Those whose interests in metallurgy are broad will be grateful for this. The others may feel that too much detail has been omitted in their particular specialty.

As a text, this should meet the requirements of almost any instructor teaching the subject to engineers or to metallurgists. By proper selection of chapters, either Production Metallurgy, Physical Metallurgy, or Engineering Metallurgy can be adequately covered regardless of where the emphasis is placed, on the ferrous or upon any of the seven important nonferrous metals. Naturally, as with every text, some amplification must be supplied by the instructor to emphasize parts which he deems particularly important. However, in partial compensation for this added labor he will find many more charts and diagrams than are usually found in similar texts as well as an extremely complete set of photomicrographs most of which are typical examples of the best work being done today by American metallographers.

There is, of course, little that is actually new in this text. It does not concern itself with the frontiers of metallurgical science. The treatment has largely followed standard procedures except for a few sections, such as those on constitutional diagrams, where some methods, which have been found to be particularly effective in classroom work, have been incorporated. Admittedly the classification of the engineering metals from an application rather than an alloy viewpoint is unconventional. However, it is, in my opinion, the only really satisfactory one. Improvements can undoubtedly be suggested but a start in the right direction has at least been made.



I am deeply grateful for and acknowledge freely the cooperation given by my many friends throughout the metallurgical industry in preparing this text. The photomicrographs are largely the result of their assistance. The late Professor O. B. Malin of The Pennsylvania State College was particularly generous in making available a collection of the best work of his students over a period of twenty years. Without the assistance and encouragement of Dean Edward Steidle and Dr. D. F. McFarland of The Pennsylvania State College, during the early stages and of Mr. D. P. Berheim and Dr. E. D. Tillyer of the American Optical Co. during the final stages the work might never have been completed.

Carl H. Samans

CHARLTON DEPOT, MASS.

# Contents

## I. General Characteristics of the Metallic Engineering Materials 1

FACTORS OF SAFETY. METALS. ALLOYS. ENGINEERING METALS. AUXILIARY METALS. STRATEGIC METALS. NOBLE METALS. METALLIC CHARACTERISTICS. OXIDATION AND REDUCTION. CHEMICAL ACTIVITY. STANDARD ELECTRODE POTENTIAL SERIES. CORROSION AND CHEMICAL ATTACK. WORK-HARDENING. HARDNESS. IMPACT STRENGTH. TENSILE STRENGTH. CREEP STRENGTH. TIME FOR RUPTURE. RELAXATION. FATIGUE STRENGTH. DAMPING CAPACITY. ELECTRICAL CONDUCTIVITY. THERMAL CONDUCTIVITY. THERMAL EXPANSION. MELTING TEMPERATURES. SPECIFIC GRAVITY. DENSENESS. NONDESTRUCTIVE TESTS. SPECIFIC HEAT. MAGNETIC PROPERTIES. SOME ECONOMIC CONSIDERATIONS. SPECIFICATIONS.

## II. The Pure Metal 64 ~

THERMAL ANALYSIS. GRAINS AND CRYSTALS. EQUILIBRIUM. GRAIN SIZE. SPACE LATTICES. DEFORMATION. SLIP. TWINNING. COLD-WORK. STRAIN RECRYSTALLIZATION. GRAIN GROWTH. ALLOTROPY. THE METAL IRON. ALLOTROPIC RECRYSTALLIZATION. HOT-WORK.

## III. Metallurgical Methods 106 ~

ORES. METALLURGICAL PROCESSES. METALLURGICAL FURNACES. CARBON AS A METALLURGICAL REDUCING AGENT.

## IV. Production of the Metals—Magnesium, Aluminum, and Zinc—From Their Ores 124

GENERAL REDUCTION PRINCIPLES. MAGNESIUM ORES. THE DOW CHLORIDE PROCESS. THE ELEKTRON PROCESS. THE DOW SEA-WATER PROCESS. THE OXIDE PROCESS. THE HANSGIRG PROCESS. THE PIDGEON PROCESS. ALUMINUM ORES. THE BAYER PROCESS. THE HALL-HEROULT PROCESS. THE HOOPES

PROCESS. THE KALUNITE PROCESS. THE ANCOR PROCESS. ZINC ORES. THE HORIZONTAL-RETORT PROCESS. THE VERTICAL-RETORT PROCESS. REDISTILLATION. THE ST. JOSEPH LEAD COMPANY'S ELECTROTHERMIC PROCESS. THE WAEZL PROCESS. THE TANTON PROCESS.

## V. The Production of Pig Iron and Cast Iron 155

IRON ORES. THE IRON BLAST FURNACE. PIG IRON. CAST IRON. CUPOLA MELTING. AIR FURNACE MELTING. MALLEABILIZING. ALLOY CAST IRONS.

## VI. Iron and Steel Making 180

HISTORICAL. WROUGHT IRON. CRUCIBLE STEEL. BESSEMER PROCESS. THE OPEN-HEARTH PROCESS. INGOT IRON. ELECTRIC PROCESS. THE INGOT STAGE.

## VII. Production of the Metals—Copper, Nickel, Lead, and Tin—From Their Ores 227

COPPER ORES. ROASTING. BLAST FURNACE SMELTING. REVERBERATORY FURNACE SMELTING. CONVERTING. FIRE REFINING. ELECTROLYTIC REFINING. HYDROMETALLURGICAL EXTRACTION. OXYGEN-FREE COPPER. NICKEL ORES. TREATMENT OF SILICATE ORES. TREATMENT OF SULFIDE ORES. THE ORFORD PROCESS. THE HYBINETTE PROCESS. THE MOND PROCESS. LEAD ORES. TREATMENT OF SULFIDE ORES. ROASTING. BLAST FURNACE SMELTING. SOFTENING OF LEAD BULLION. THE PARKES PROCESS. DEZINCING. DEBISMUTHIZING. THE BETTS PROCESS. THE WAEZL PROCESS. TIN ORES. BLAST-FURNACE SMELTING. REVERBERATORY-FURNACE SMELTING. PYROMETALLURGICAL REFINING. ELECTROLYTIC REFINING.

## VIII. The Theory of Alloys 262

LIQUID SOLUTIONS. COMPONENTS. POWDER METALLURGY. DIFFUSION. PHASES. CONSTITUTIONAL DIAGRAMS. TYPES OF PHASES IN BINARY ALLOYS. TYPICAL BINARY ALLOY SYSTEMS. DIAGRAMS WITH COMPLETE SOLUBILITY IN BOTH SOLID AND LIQUID STATE. THE COMPOSITION RULE. THE LEVER RULE. NONEQUILIBRIUM SOLIDIFICATION. DIAGRAMS WITH PARTIAL SOLID SOLUBILITY. THE EUTECTIC. THE 1:2:1 RULE. DIAGRAMS WITH ONE OR MORE INTERMETALLIC COMPOUNDS. THE PERITECTIC REACTION. THE COPPER-ZINC DIAGRAM. THE COPPER-TIN DIAGRAM. THE IRON-CARBON DIAGRAM. THE EUTECTOID. STRUCTURAL CHANGES IN IRON-CARBON ALLOYS DURING SLOW COOLING. IRON BINARY ALLOYS. EFFECT OF CARBON ON IRON BINARY ALLOYS. S.A.E. STEEL NUMBERING SYSTEM. THE IRON-GRAPHITE DIAGRAM. GRAY CAST IRON. WHITE CAST IRON.

## IX. The Principles of Heat-Treatment 335

ENERGY INTENSITIES. STRESS RELIEF. TIME FACTOR. AGE-HARDENING. SUBCRITICAL ISOTHERMAL TRANSFORMATION OF AUSTENITE. PEARLITE. BAINITE. MARTENSITE. EFFECT OF RATE OF COOLING ON TRANSFORMATION

OF AUSTENITE. DECOMPOSITION OF MARTENSITE ON REHEATING. PROPERTIES OF TEMPERED STEEL VS. CARBON CONTENT. LAMELLAR VS. SPHEROIDAL STRUCTURES. EFFECT OF AUSTENITE GRAIN SIZE ON TRANSFORMATION OF AUSTENITE. EFFECT OF ALLOYING ELEMENTS. MALLEABILIZING. COMMERCIAL HEAT-TREATMENTS. AUSTEMPERING. BRIGHT ANNEALING. QUENCHING. INTERRUPTED QUENCHING. HARDENABILITY. EFFECTS OF ALLOYING ELEMENTS ON HARDENABILITY. TEMPERING.

## X. Shaping and Forming the Metallic Materials 390

CASTING. INVESTMENT CASTING. CENTRIFUGAL CASTING. CONTINUOUS CASTING. DIE AND PRESSURE CASTING. HOT EXTRUSION. SPECIAL MODIFICATIONS OF EXTRUSION. THE HOOKER PROCESS. IMPACT EXTRUSION. HOT-WORK. COLD-WORK. BLUE BRITTLE RANGE IN STEEL. ROLLING. HAMMER FORGING. PRESS FORGING. SWAGING. WELDED PIPE. SEAMLESS PIPE AND TUBING. PIERCING. TUBE ROLLING. HOT-FINISHING OF TUBES. CUPPING. CASI-SHELL PROCESS. DRAWING. SINKING. COLD-FORMING. POWDER METALLURGY. METHODS OF ADDING METAL. FORGE WELDING. THERMIT WELDING. RESISTANCE WELDING. GAS WELDING. ATOMIC-HYDROGEN WELDING. ARC WELDING. SUBMERGED MELT WELDING. MACHINABILITY. RELATIVE MACHINABILITIES OF ALLOYS. FLAME-CUTTING. ELECTRIC-ARC CUTTING. GRINDING. THE SPARK TEST.

## XI. Corrosion, Its Effects and Control 484

CONTROLLING FACTORS. ACCELERATING FACTORS. GALVANIC SERIES IN SEA WATER. FORMS OF CORROSION. CORROSION TESTING. METALS AND ALLOYS RESISTANT TO CORROSION. ECONOMIC FACTORS.

## XII. Protecting Metals Against Corrosion 498

HOT DIPPING. ELECTROPLATING. CEMENTATION. METAL SPRAYING. METAL CLADDING. PROTECTIVE FILM FORMATION. PAINTING. VITREOUS ENAMELING.

## XIII. Alloys Used Largely Because of Ease of Fabrication 525

INGOT IRON. COPPER-BEARING IRON. MILD STEEL. S.A.E. 1010. AGING. ANNEALING FOR MAXIMUM DUCTILITY. DUCTILITY TESTERS. COPPER. HYDROGEN EMBRITTLEMENT. ALPHA BRASSES. NICKEL SILVER. WORK-HARDENABLE ALUMINUM ALLOYS. HEAT-TREATABLE ALUMINUM ALLOYS. WROUGHT MAGNESIUM ALLOYS. LEAD AND ITS ALLOYS. NICKEL AND MONEL METAL. ROLLED ZINC ALLOYS. FREE-MACHINING ALLOYS. STEEL SCREW-MACHINE STOCK. FREE-MACHINING BRASSES. ZINC-BASE DIE CASTINGS. COPPER-BASE DIE CASTINGS. PEWTER.

## XIV. Pipe, Tubing, and Castings Resistant to Water Corrosion 572

WROUGHT IRON. MILD STEEL AND CAST IRON. COPPER AND BRASS PIPE. MUNTZ METAL. ADMIRALTY METAL. ALUMINUM BRASSES. NAVAL BRASS.

CUPRONICKEL. ADNIC. AMBRAC. ALUMINUM BRONZE. CAST RED BRASS. YELLOW BRASS. 88:10:2 BRONZE. ALUMINUM ALLOYS.

## XV. Alloys Resistant to Chemical Corrosion and the Action of Heat 593

CREEP. LOW-CARBON AND INTERMEDIATE-ALLOY STEELS. 4-6 CHROMIUM STEEL. HARDENABLE STAINLESS STEELS. FERRITIC STAINLESS STEELS. SIL-CHROME. 20-30% CHROMIUM IRONS. AUSTENITIC STAINLESS STEELS. SENSITIZATION. MODIFIED 18:8 STEELS. PRECIPITATION-HARDENABLE 18:8 STEELS. CHROMIUM-NICKEL-MOLYBDENUM TYPE STAINLESS STEEL. 29:9 ALLOYS. 25:30 AND 15:35 ALLOYS. NICHROME. HIGH-SILICON CAST IRON. AUSTENITIC CAST IRON. HEAT-RESISTING CAST IRON. NICKELS. MONEL ALLOYS. INCONEL. HASTELLOYS. ILLIUM. KONAL. SUPER-HEAT-RESISTANT ALLOYS. LEAD ALLOYS. CAST ALUMINUM PISTON ALLOYS. CAST ALUMINUM CRANKCASE AND CYLINDER-HEAD ALLOYS.

## XVI. Alloys for Applications Requiring High Strength and Toughness 664

RELATIVE STRENGTH PROPERTIES. STRUCTURAL STEELS. BRIDGE CABLE. 18:8 STAINLESS STEEL. AUTOMOTIVE STEELS. CASE-CARBURIZING STEELS. ALLOY CARBURIZING STEELS. HEAT-TREATING STEELS. FORGING STEELS. SPRING STEELS. NATIONAL EMERGENCY STEELS. CARBON-STEEL CASTINGS. LOW-ALLOY CAST STEELS. GRAY CAST IRON. HIGH-TEST CAST IRON. HIGH-STRENGTH CAST IRON. HEAT-TREATED CAST IRON. MEEHANITE. MALLEABLE CAST IRON. DURALUMIN-TYPE ALLOYS. HIDUMINIUM R.R. 77. ALCOA 75S. ALUMINUM FORGING ALLOYS. HIGH-STRENGTH ALUMINUM CASTING ALLOYS. HIGH-STRENGTH MAGNESIUM ALLOYS. SILICON BRONZES. BRONZE. NICKEL BRONZE. MANGANESE BRONZE. BERYLLIUM COPPER. COPPER-MANGANESE-NICKEL ALLOYS.

## XVII. Alloys Resistant to General Wear and Abrasion 731

SURFACE HARDENING. INDUCTION HARDENING. FLAME-HARDENING. CASE CARBURIZING. MCQUAID-EHN TEST. NITRIDING. ELECTROPLATING. CARBON RAIL STEELS, HIGH-MANGANESE STEEL. WEAR-RESISTANT GRAY IRON. WHITE AND CHILLED IRON. WEAR-RESISTING ALLOY CAST IRONS. BALL AND ROLLER BEARINGS. ALUMINUM BRONZE.



## XVIII. Tool Materials

760

TOOL STEELS. HEAT TREATMENT. COLD TREATMENT. HISTORICAL. TESTING. CLASSIFICATION. TOOLS FOR COLD CUTTING AND FORMING. PLAIN-CARBON STEELS. TEMPER COLORS. HIGH-CARBON, LOW-TUNGSTEN STEELS. SILICON-MANGANESE PUNCH AND CHISEL STEELS. LOW-CHROMIUM AND CHROMIUM-VANADIUM STEELS. MANGANESE NONDEFORMING DIE STEELS. HIGH-

CARBON, HIGH-CHROMIUM DIE STEELS. TUNGSTEN-ALLOY CHISEL AND PUNCH STEELS. CHROMIUM DIE STEELS FOR HOT WORK. TUNGSTEN DIE STEELS. TUNGSTEN-CHROMIUM DIE STEELS. HIGH-SPEED STEELS. MOLYBDENUM HIGH-SPEED STEELS. COBALT HIGH-SPEED STEELS. GRAPHITIC STEELS. SINTERED CARBIDES. CAST COBALT-CHROMIUM-TUNGSTEN ALLOYS. CAST IRON DIES. ZINC-ALLOY STAMPING DIES. NONSPARKING TOOLS.

## XIX. Bearing Alloys

801

GENERAL REQUIREMENTS. CLASSIFICATION. TESTING. FABRICATION. TIN-BASE BABBITTS. LEAD-BASE BABBITTS. CADMIUM-BASE ALLOYS. ZINC-BASE BEARING ALLOYS. ALUMINUM-BASE BEARING ALLOYS. THE BEARING BRONZES. GRAPHITE BRONZE. SILVER-BASE BEARING ALLOYS. LEADED BABBITTS. HIGH-TIN LEAD-BASE ALLOYS. LOW-TIN LEAD-BASE ALLOYS. LEAD-ANTIMONY BEARINGS. LEAD-ALKALI AND LEAD-ALKALINE EARTH ALLOYS. IRON POWDER BEARINGS.

## XX. Alloys Used Because of Their Special Physical Properties

832

CONDUCTIVITY COPPERS. ALUMINUM CONDUCTORS. FREE-MACHINING HIGH-CONDUCTIVITY COPPERS. CONDUCTIVITY BRONZES. COPPER-NICKEL RESISTANCE ALLOYS. MANGANIN. NICKEL-CHROMIUM RESISTANCE ALLOYS. IRON-NICKEL-CHROMIUM RESISTANCE ALLOYS. MOLYBDENUM AND TUNGSTEN HEATING UNITS. IRON-CHROMIUM-ALUMINUM RESISTANCE ALLOYS. SILICON CARBIDE HEATING ELEMENTS. THERMOELECTRIC MATERIALS. ALLOYS WITH LOW THERMAL EXPANSION. ALLOYS WITH CONTROLLED EXPANSION. ALLOYS WITH LOW THERMOELASTIC COEFFICIENTS. FUSIBLE ALLOYS. SOFT SOLDERS. SUBSTITUTE SOLDERS. SILVER BRAZING ALLOYS. BRAZING ALLOYS. MAGNET STEELS. PRECIPITATION-HARDENING MAGNET ALLOYS. MAGNETICALLY SOFT MATERIALS. THE EPSTEIN TEST. SILICON TRANSFORMER STEELS. ALLOYS WITH SPECIAL MAGNETIC CHARACTERISTICS.



# I General Characteristics of the Metallic Engineering Materials

## METALLURGY

**M**ETALLURGY INCLUDES WITHIN ITS SCOPE NOT ONLY THE extraction of metals from their ores, but also the subsequent combination, fabrication, and treatment of these metals, for the purpose of developing in them the characteristics which will be of the greatest value in engineering. Metallurgy is one of the oldest of the arts, and yet one of the newest of the sciences. Its progress and development have paralleled the technological development of modern industry.

## THE SCIENCE OF METALLOGRAPHY

*All metallic materials are crystalline.* Hence, all the characteristics of these materials are determined either by the nature of the minute crystals of which they are composed, or by the manner in which these crystals are aggregated into larger masses. For example, a piece of metal composed of small grains generally will be somewhat stronger and harder than an otherwise identical piece composed of large grains, and the general characteristics of a metal composed of only one type of crystal will differ from those of one composed of two or more different types of crystals.

However, it was not until the latter years of the nineteenth century that these simple facts became appreciated. For thousands of years numerous metals had been available in some form; but their production, improvement, and utilization had been an art, usually discovered by accident and passed down from master to favored apprentice through the ages. Not until Henry C. Sorby published in England, in 1886, his microscopic studies on meteorites and on iron and steel was any method or information available for correlating the structure of the metallic materials with their composition and treatment, and with the mechanical and physical properties which determine their ultimate application. The pioneer microscopic work of



Sorby and his successors, upon which the modern science of *metallography* is based, was largely responsible for the impetus which transformed metallurgy from the art that it had been into the science that it has become today.

#### METALLURGY AND ENGINEERING

The tremendous technological developments of the present century have been made possible only by close cooperation between the engineer and the metallurgist. In the United States, in particular, this has been true because, under the American system of efficient mass production, the utmost in uniformity and reproducibility is required of nearly every type of metal used. The production line, developed so successfully by the automotive industry, would never have been possible unless each piece of metal used could be machined, formed, or heat-treated to definite mechanical properties with accurate timing and a minimum of variation. Only by a proper correlation between engineering design and metallurgical development and control can this high efficiency be maintained.

Consequently, it is of the greatest importance that the engineer understand thoroughly not only the possibilities but also the limitations of the metallic materials. With this understanding he is equipped to use more efficiently the materials available, and to select suitable substitutes for them when substitution becomes necessary; to correct the minor problems of a metallurgical nature that arise in plant operation; and to cooperate intelligently with the metallurgist when he is called in to assist in solving the more complex problems.

#### FACTORS OF SAFETY IN ENGINEERING DESIGN

Nowhere is ignorance of materials more forcibly illustrated than in the use of arbitrary *factors of safety*. Although it is true that usually some allowance must be made to compensate for complexities of stresses which cannot be predicted or evaluated, in too many instances so little is known by the engineer about the reactions of specific materials to stress, corrosion, erosion, and other deteriorating influences, that these allowances are more *factors of ignorance* than anything else.

A better and more thorough knowledge of materials on the part of engineers should result in lower factors of safety in many instances and more economic designs. Although sound judgment, based upon experience and tempered with caution, still will be needed, the materials available must be used where they are best suited, and this requires knowledge and experience of a metallurgical as well as of an engineering nature.

## METALS

The metals are chemical elements. As such, they are composed, essentially, of atoms which, in turn, are specific combinations of electrically charged particles called *protons* (+), *neutrons* (no charge), and *electrons* (-). The various chemical elements differ in the positive charge on their atomic nucleus, and in the number of both tightly bound and free or valence electrons which they possess outside of this nucleus. Since the atom, as a whole, must be electrically neutral, the positive charge of the nucleus must equal the negative charge of the electrons. The magnitude of either of these charges determines the *atomic number* of the element. As far as is known, the *atomic weight* is determined almost entirely by the protons and neutrons, both of which have nearly identical masses and are found only in the atomic nucleus. The hydrogen atom, the simplest known, with an atomic weight of 1.008, would have one proton in its nucleus and one free or valence electron outside it. Were it not for the neutrons all the other chemical elements would have simple multiples of this structure, except as regards the distribution of the electrons as mentioned above, depending upon their atomic numbers. Their atomic weights would be, therefore, simple multiples of that of the hydrogen atom. The presence of neutrons as additional masses in their nuclei, however, not only gives them atomic weights which are not simple multiples of that of hydrogen but also results in the occurrence of *isotopes*. Isotopes are different varieties of the same element having the same number of positive and negative charges, and hence the same atomic number, but different atomic weights because of the presence, in their nucleus, of additional mass-increasing neutrons. As far as is known, all isotopes of a given element are chemically identical but some of them may differ in other respects, such as radioactivity, for example.

Both the nucleus and the free electrons seem to be significant in determining the properties of a material, although as yet not enough is known concerning the relationships involved to be of practical use. The nucleus and free electrons, however, apparently determine in some manner the geometrical positions of the atoms in the metal crystal as well as the unique metallic linkages which hold these atoms together and maintain these positions. Hence, they have an important effect upon all the chemical, mechanical, and physical characteristics of the metallic materials. It is these characteristics that determine what are called the properties of the material.

Of the ninety-two<sup>1</sup> chemical elements in the periodic table (Fig. 1), about seventy are metallic; and a few more are borderline cases between the met-

<sup>1</sup> The so-called transuranium metallic elements, such as *plutonium* and *neptunium*, which have atomic numbers greater than ninety-two and have been produced in recent years by special procedures are not discussed in this text.

	1A	2A	3A	4A	5A	6A	7A	8	1B	2B	3B	4B	5B	6B	7B	0		
1	1 H 1.008														1 H 1.008	2 He 4.002		
2	3 Li 6.94	4 Be 9.02									5 B 10.82	6 C 12.00	7 N 14.008	8 O 16.000	9 F 19.00	10 Ne 20.18		
3	11 Na 23.00	12 Mg 24.32	13 Al 26.97								13 Al 26.97	14 Si 28.06	15 P 31.0	16 S 32.06	17 Cl 35.46	18 Ar 39.94		
4	19 K 39.10	20 Ca 40.08	21 Sc 45.10	22 Ti 47.90	23 V 50.95	24 Cr 52.01	25 Mn 54.93	26 Fe 55.84	27 Co 58.94	28 Ni 58.69	29 Cu 63.57	30 Zn 65.38	31 Ga 69.72	32 Ge 72.60	33 As 74.91	34 Se 78.96	35 Br 79.92	36 Kr 83.7
5	37 Rb 85.48	38 Sr 87.63	39 Y 88.92	40 Zr 91.22	41 Nb 93	42 Mo 96.0	43 Tc 97.8	44 Ru 101.7	45 Rh 102.91	46 Pd 106.7	47 Ag 107.88	48 Cd 112.41	49 In 114.76	50 Sn 118.70	51 Sb 121.76	52 Te 127.61	53 I 126.92	54 Xe 131.3
6	55 Cs 132.91	56 Ba 137.36	57-71 Rare Earths	72 Hf 178.6	73 Ta 181	74 W 184	75 Re 186.31	76 Os 191	77 Ir 193.1	78 Pt 195.23	79 Au 197.2	80 Hg 200.61	81 Tl 204.39	82 Pb 207.2	83 Bi 209.00	84 Po (210)	85 At (212)	86 Rn 222
7	87 Fr (223)	88 Ra 226	89 Ac (227)	90 Th 232.12	91 Pa 231	92 U 238.1												

Rare Earths	57 La 138.92	58 Ce 140.13	59 Pr 140.92	60 Nd 144.27	61 Pm (146)	62 Sm 150.43	63 Eu 152.0	
	64 Gd 157	65 Tb 159.2	66 Dy 162.46	67 Ho 163.5	68 Er 166	69 Tm 169.4	70 Yb 173.04	71 Lu 175.0

FIGURE 1. The periodic table of the chemical elements. All the elements to the left of the heavy line are metallic. Arsenic, selenium, and tellurium are borderline elements. (Modified and reproduced with permission from *Chapters in the Chemistry of the Less Familiar Elements* by B. S. Hopkins.)

als and the nonmetals. Near room temperature most of the metals are solid; but four of them: *mercury*, *gallium*, *rubidium*, and *cesium*, can be liquid; and one element, which behaves like a metal chemically, viz., *hydrogen*, is a gas. About three-quarters of the metals today are used industrially to some extent.

## ALLOYS

Usually, the properties of a given metal are not entirely satisfactory for a definite application, and must be modified in some manner. The addition of other metals or nonmetals to a metallic base alters its properties by forming an alloy. However, the components of the alloy must be intimately mixed, preferably by first forming a solution in the liquid state; and metallic characteristics must predominate. It is customary to refer to such additional elements as *impurities* if they are added accidentally or unintentionally, and as *alloying elements* if they are added deliberately. The general effects of both impurities and alloying elements are similar, of course, usually differing only in degree.

Nearly all the metals will alloy with each other to some extent. However, under normal conditions, some metals are much more important than others either for economic reasons or because they possess unique properties. The most important basic metals will be referred to as the *engineering metals*, those used in the greatest quantities and predominating in a majority of the commercial alloys. Next most important are the metals which impart particularly advantageous properties to the engineering metals when they are alloyed with them, or which are almost indispensable for other reasons, sometimes chemical rather than metallurgical. These will be called the *auxiliary metals*. Finally, there are the *noble* or *precious metals* which have a somewhat greater permanence than the other metals because they resist the action of many chemicals, and hence, in a few instances like gold and silver, have enjoyed some prominence as monetary standards. In addition, the noble metals frequently make rather extraordinary alloys for special purposes in which their comparatively high cost is not too important a factor.

#### THE ENGINEERING METALS

Of the forty odd metals used commercially, only eight are available in sufficient quantity to serve as the bases of the common engineering alloys. Four of these eight: *copper*, *iron*, *lead*, and *tin*, have been used for thousands of years, both in the impure and in the alloyed forms. The remaining four, however: *aluminum*, *magnesium*, *nickel*, and *zinc*, are relatively new additions, their commercial use as metal dating only to the latter part of the nineteenth century, even though alloys containing zinc, e.g., the brasses, had been used for centuries and nickel had been a useful constituent of many irons, especially those of meteoric origin. All the remaining metals seem to be excluded at present from this group of basic engineering metals either because of inadequate sources of supply, or of economically unfeasible methods of production. However, some of these other metals serve as the bases of special alloys used only in restricted amounts; and many of them, as will be seen later, are present in sizable percentages in commercial alloys, and determine the important properties of these alloys, even though they are not the basic metal present.

#### FERROUS AND NONFERROUS ALLOYS

The alloys of these eight metals generally are classified as ferrous, if their properties are basically those of the metal iron, or nonferrous, if their properties are basically those of any of the metals other than iron. The relative

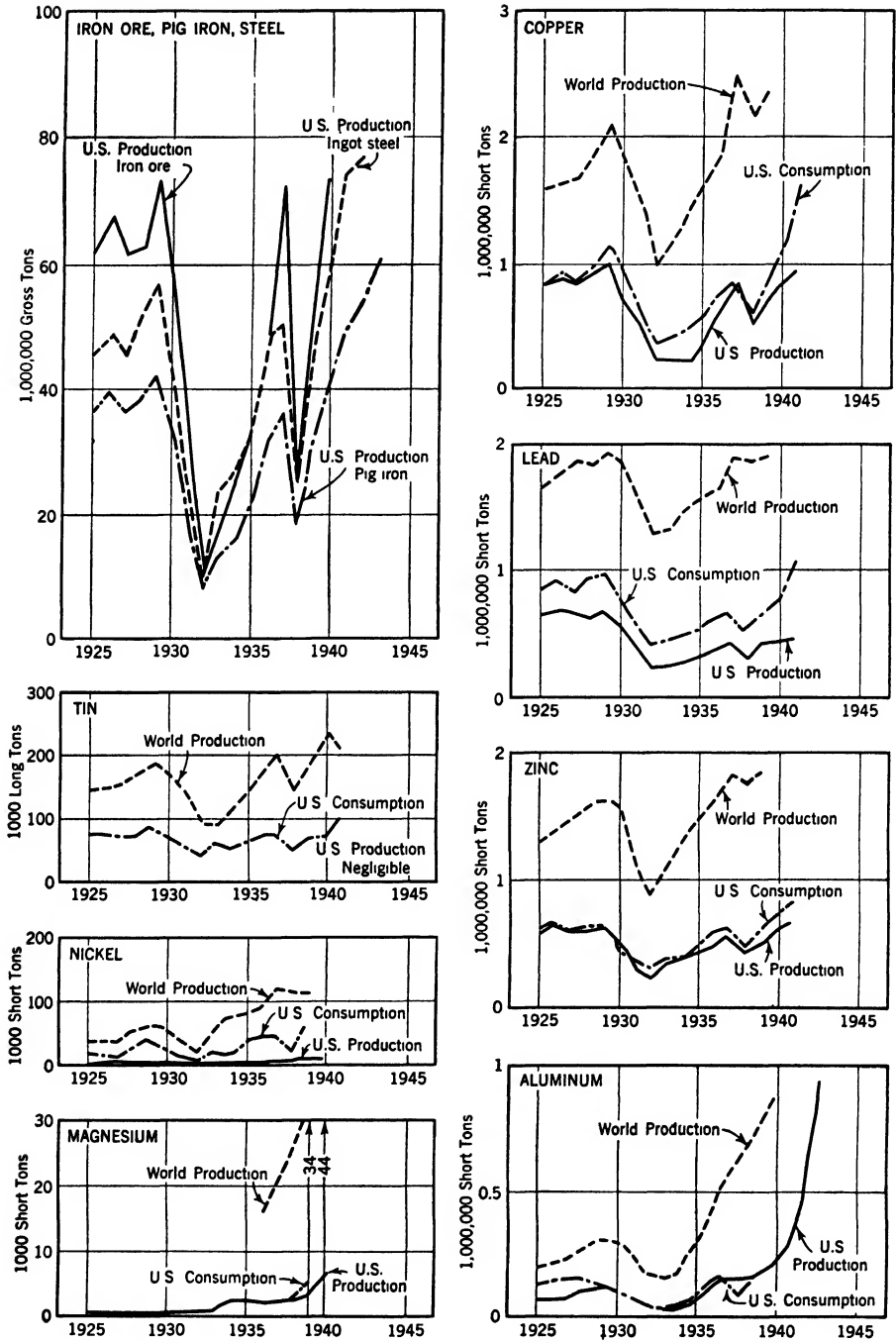


FIGURE 2. World production and United States production and consumption of the engineering metals since 1925. (After U. S. Bureau of Mines data.)

importance of the two groups can be appreciated from the tonnage of each produced, both in the United States and in the world, since 1925, and the tonnage consumed in the United States, as indicated in Fig. 2.

It must be emphasized, however, that other than this somewhat arbitrary classification there is no essential difference between the two groups, and that the same fundamental principles will apply to similar alloys of either class. Although it is true that a greater tonnage of the ferrous than of the nonferrous materials is used today and that, for this reason, more attention will be devoted to them here, the basic similarity of all metals and alloys must not be forgotten.

#### THE AUXILIARY METALS

In addition to the engineering metals, there are thirteen other metallic elements which are important either in the metallurgical or chemical industries. In this group are included *antimony, beryllium, cadmium, chromium, cobalt, columbium, manganese, mercury, molybdenum, titanium, tungsten, vanadium, and zirconium*. These will be termed the auxiliary metals.

#### STRATEGIC METALS

Eight of these twenty-one vitally important metals: *antimony, chromium, cobalt, manganese, mercury, nickel, tin, and tungsten*, are available in the United States in insufficient amounts; hence they largely must be imported. The uses and chief sources of supply of these metals in the past are listed in Table I.

TABLE I THE STRATEGIC METALS

	IMPORTANT USES	PRINCIPAL SOURCES OF SUPPLY
Antimony	Storage batteries, cable sheathing	Mexico, South America
Chromium	Alloy steels	Turkey, Rhodesia, New Caledonia
Cobalt	Tool and magnetic alloys	Canada, Rhodesia, Belgian Congo
Manganese	Steel-making necessity	U.S.S.R., India, African Gold Coast
Mercury	Chemical, electrical	Mexico, Spain, Italy
<i>Nickel</i>	Alloy steels and cast irons	Canada, New Caledonia
Tungsten	Tool steels and lamp filaments	China
<i>Tin</i>	Bearing metals, solders, tin plate	British Malaya, Netherland Indies, Bolivia, Belgian Congo

These metals, the lack of which would interfere seriously with the functioning of American industrial and economic programs, will be termed the

strategic metals. Naturally, any metal may become strategic if the demands for it are great and the supplies are small. Hence, the eight metals shown are only the most prominent ones of a list that could be much longer.

#### NOBLE METALS

The noble or precious metals are relatively inactive chemically, and are available only in limited amounts. Some of them, notably gold and silver, have had a certain monetary value in the past because of their use as mediums for international exchange, and have found limited application, because of this monetary usage, in both the pure and the alloyed forms. Future developments in the use of the noble metals are unpredictable because of changing world economic conditions, but the properties of most of them are so unusual that many more practical applications may well ensue, if their high cost can be justified.

In this group are included the well-known *gold*, *platinum*, and *silver*, and the lesser known *iridium*, *osmium*, *palladium*, *rhodium*, and *ruthenium*.

#### THE METALLIC CHARACTERISTICS

The metallic materials are important in engineering because they possess certain unique characteristics, such as their ability to become hardened and strengthened by deformation, and in some instances by heat-treatment, and their ability to conduct electricity and heat. In addition, most metals can be formed into the particular shapes found to be best suited to engineering designs, and, in those shapes, can be given a satisfactory combination of properties with which to resist overload and failure.

All of these characteristics relate back, in some manner not as yet completely understood, to the structure of the individual atoms, and to the way in which these atoms are packed together to form crystals and crystal aggregates. Consequently, different metallic elements possess these characteristics in different degrees. An understanding of their significance, and of the methods by which they can be modified, is essential to the efficient use of metals and alloys.

The characteristics of the nonmetals differ markedly from those of the metals because of the different manner in which the atoms of the nonmetals are built up and arranged. Nonmetals neither behave similarly chemically, conduct heat or electricity so readily, nor are so workable as the metals. Usually, too, they reflect light differently, which has given rise to the term metallic luster to describe a metal's characteristic appearance. In some characteristics, such as strength, especially per unit of weight, and resist-

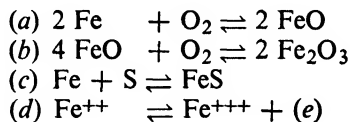
ance to chemicals, some of the ceramic and plastic materials are superior to the metals, even though they frequently possess other properties at the same time which are not so desirable.

### *Chemical Properties*

#### OXIDATION AND REDUCTION

Since metals are chemical elements, the general laws of chemistry are applicable to them. If a metal, for example, increases its positive charge it is said to be oxidized, whereas if it decreases its positive charge it is said to be reduced. It always must be remembered, however, that attention thus has been directed to only one side of the process, and that, if a metal is oxidized, something else must be reduced simultaneously and vice versa.

It also should be noted that for true chemical oxidation an addition of oxygen is not necessarily required, as in each of the following examples oxidation occurs if the reaction proceeds from left to right, just as reduction occurs if it proceeds from right to left:

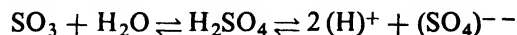


#### ACIDS AND BASES

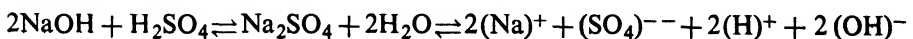
Frequently, the chemical oxidation or reduction takes place in water solution, and the products of the reaction appear as charged particles known as *ions*. If a metallic oxide is placed in water solution, it is found that both metallic ( $M^+$ ) and hydroxyl ( $\text{OH}^-$ ) ions are formed. The solution is then said to be *basic* or *alkaline*:



On the other hand, if a nonmetallic oxide is placed in water solution, it is found that hydrogen ( $\text{H}^+$ ) and nonmetallic ( $\text{R}^-$ ) ions are formed; and the solution is said to be *acid*:



The reaction between a base and an acid will give a *salt* and water; and if the salt so formed is at all soluble in water, then it, too, will be ionized to some extent:





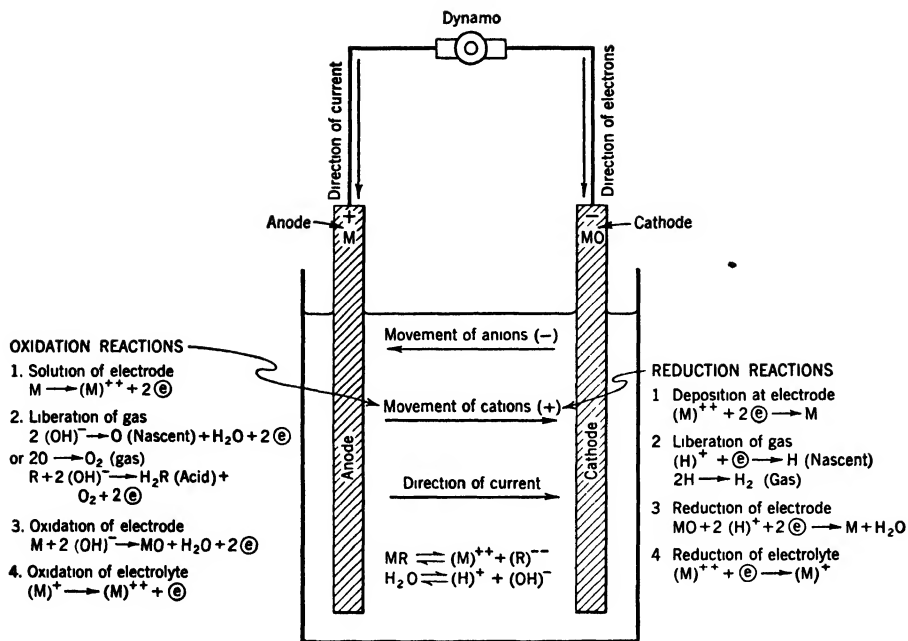


FIGURE 3. Ion and current movements in a simple electrolytic cell showing some typical reactions that may occur.

Any solution containing ions will conduct electricity, and is known as an *electrolyte*.

#### DIFFERENCE IN POTENTIAL BETWEEN A METAL AND A SOLUTION

If a metallic electrode is immersed in a solution containing its ions, a difference in potential will be set up between the metal and the solution which may be determined from measurements made with any known reference electrode. It will be found that the magnitude of this potential will vary with the *temperature*, the *pressure*, and the *concentration* of the solution.

If two connected electrodes are placed in an electrolyte with a difference in potential between them, as in Fig. 3, a current will flow. The positive charged metal *cations* will tend to move toward the negative electrode or *cathode*, take on a negative charge, and be reduced to the metallic state. Simultaneously, the negative charged nonmetallic *anions* will tend to move toward the positive electrode or *anode*, lose their negative charge, and become oxidized to the atomic state. *Reduction* thus tends to take place at the cathode, and *oxidation* at the anode.

Reduction at the cathode may result either in the deposition of a metal or of hydrogen at the electrode, or in the reduction of the electrode itself or of the electrolyte near it. Oxidation at the anode may result either in the solu-

tion of the electrode, in the oxidation of the electrode or of the electrolyte near it, or in liberation of oxygen or a similar gas.

#### CHEMICAL ACTIVITY

The specific process occurring at a given electrode is affected both by the conditions and by the chemical activity of the electrode material with reference to the solution. Some measure of this chemical activity can be secured by determining the difference in potential between metals and solutions of definite concentrations of their salts, or between the metallic and ionic states of the metals.

If the metals are listed, as in Table II, according to increasing positive values of such potential differences, when secured under comparable conditions, it will be found that they also are listed, in general, according to their chemical activity.

The more active (*electropositive*) elements are near the top of such a list and the more inert (*electronegative*) ones near the bottom. Positions in such a table are only relative, and are likely to vary if the conditions under which the data are secured are changed. The exact numerical value of this potential difference, moreover, has little significance. Even so, qualitatively such a table is of great value in indicating how various metals might be expected to react under comparable conditions.

#### CHEMICAL ACTIVITY AND EASE OF REDUCTION

The more electropositive an element is, the more difficult will it be to reduce it *completely*<sup>2</sup> to the metallic state once it is oxidized and the greater will be the energy absorbed in the reduction. This electropositive nature would be indicated roughly by the temperature at which the reduction will take place if the other conditions are maintained, because temperature is an indication of the intensity of energy required to start and carry on a reaction, i.e., of the mobility of the atoms.

Metals higher in the series than manganese require very large amounts of energy, and can be reduced best at the high temperatures produced by using the electric arc. Even then, a strong reducing agent, such as carbon or a highly electropositive metal, must be present. Hydrogen, for example, would be relatively ineffective, except under very carefully controlled conditions, chiefly because the water vapor that would of necessity be formed would be too highly dissociated at the temperatures required. In addition,

<sup>2</sup> Provided the temperature is high enough for a reaction to take place there always will be some reduction although it probably will be far from complete. The practical significance of this is discussed more thoroughly in Chap. IV.

TABLE II CHEMICAL ACTIVITY OF SOME OF THE COMMON METALS AT ROOM TEMPERATURE, AS INDICATED BY STANDARD ELECTRODE POTENTIALS<sup>1</sup>

ELECTRODE REACTION	ELECTRODE POTENTIAL
Li $\rightarrow$ Li <sup>+</sup> + $\textcircled{e}$	2.96
K $\rightarrow$ K <sup>+</sup> + $\textcircled{e}$	2.92
Ba $\rightarrow$ Ba <sup>++</sup> + 2 $\textcircled{e}$	2.90
Ca $\rightarrow$ Ca <sup>++</sup> + 2 $\textcircled{e}$	2.87
Na $\rightarrow$ Na <sup>+</sup> + $\textcircled{e}$	2.71
<i>Mg</i> $\rightarrow$ Mg <sup>++</sup> + 2 $\textcircled{e}$	2.40
<i>Al</i> $\rightarrow$ Al <sup>+++</sup> + 3 $\textcircled{e}$	1.70
<i>Be</i> $\rightarrow$ Be <sup>++</sup> + 2 $\textcircled{e}$	1.69
<i>Mn</i> $\rightarrow$ Mn <sup>++</sup> + 2 $\textcircled{e}$	1.10
<i>Zn</i> $\rightarrow$ Zn <sup>++</sup> + 2 $\textcircled{e}$	0.76
<i>Cr</i> $\rightarrow$ Cr <sup>++</sup> + 2 $\textcircled{e}$	0.56
<i>S</i> $\rightarrow$ S <sup>--</sup> - 2 $\textcircled{e}$	0.51
<i>Fe</i> $\rightarrow$ Fe <sup>++</sup> + 2 $\textcircled{e}$	0.44
<i>Cd</i> $\rightarrow$ Cd <sup>++</sup> + 2 $\textcircled{e}$	0.40
<i>In</i> $\rightarrow$ In <sup>+++</sup> + 3 $\textcircled{e}$	0.34
<i>Co</i> $\rightarrow$ Co <sup>++</sup> + 2 $\textcircled{e}$	0.28
<i>Ni</i> $\rightarrow$ Ni <sup>++</sup> + 2 $\textcircled{e}$	0.23
<i>Sn</i> $\rightarrow$ Sn <sup>++</sup> + 2 $\textcircled{e}$	0.14
<i>Pb</i> $\rightarrow$ Pb <sup>++</sup> + 2 $\textcircled{e}$	0.12
H <sub>2</sub> $\rightarrow$ 2 H <sup>+</sup> + 2 $\textcircled{e}$	0.00
<i>Sb</i> $\rightarrow$ Sb <sup>+++</sup> + 3 $\textcircled{e}$	-0.10
<i>Bi</i> $\rightarrow$ Bi <sup>+++</sup> + 3 $\textcircled{e}$	-0.23
<i>As</i> $\rightarrow$ As <sup>+++</sup> + 3 $\textcircled{e}$	-0.30
<i>Cu</i> $\rightarrow$ Cu <sup>+</sup> + $\textcircled{e}$	-0.47
<i>Hg</i> $\rightarrow$ Hg <sup>+</sup> + $\textcircled{e}$	-0.80
<i>Ag</i> $\rightarrow$ Ag <sup>+</sup> + $\textcircled{e}$	-0.80
<i>Pd</i> $\rightarrow$ Pd <sup>++</sup> + 2 $\textcircled{e}$	-0.82
<i>Pt</i> $\rightarrow$ Pt <sup>++++</sup> + 4 $\textcircled{e}$	-0.86
<i>Au</i> $\rightarrow$ Au <sup>+++</sup> + 3 $\textcircled{e}$	-1.36

<sup>1</sup>From *Oxidation Potentials*, by W. M. Latimer: Prentice-Hall, Inc., New York, 1938.

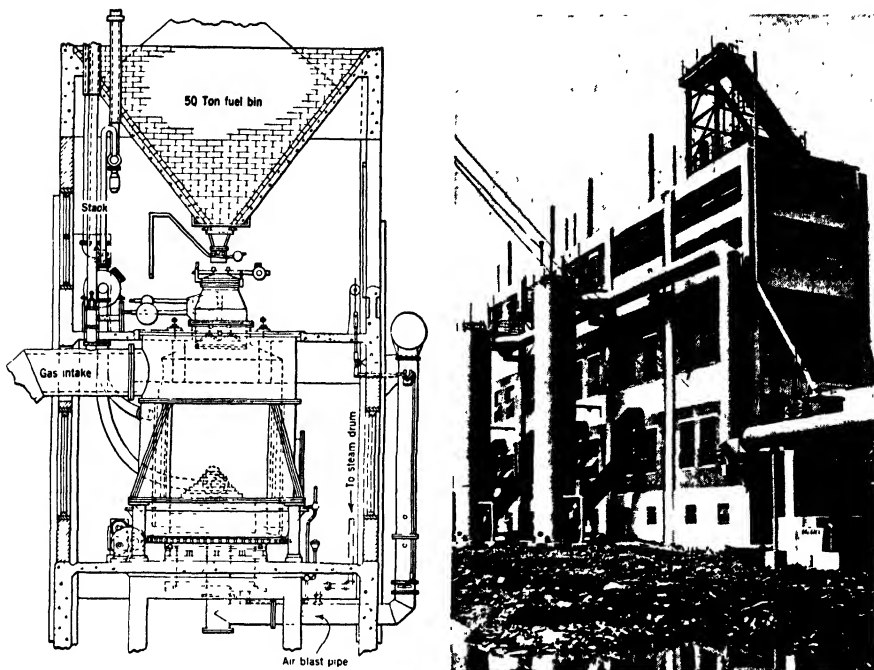
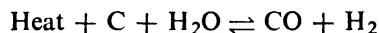


FIGURE 4. A commercial gas producer plant. (Left) General arrangement of a single gas producer shown in cross section. (Right) External view of a modern plant of four 10-ft diameter producers with a separate blower and booster house. (Courtesy Koppers Company.)

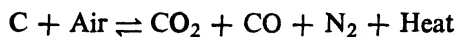
hydrogen probably, at that temperature, would be less active chemically than the metal being reduced and hence would have little tendency to replace it. These highly electropositive metals cannot be reduced at all from aqueous solution because they react chemically with the water, releasing the hydrogen and combining with the oxygen.

For metals of intermediate activity, the temperatures produced by fuel fires generally will be satisfactory. For these metals, carbon can serve not only as a reducing agent, but also as a fuel. It is of interest to note in this respect that the *water gas* reaction:



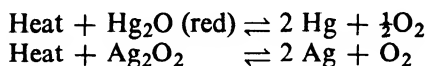
is typical of this group, the hydrogen being reduced from its oxide, water in the form of steam, by the action of carbon at elevated temperatures.

A gas producer used for this purpose is illustrated diagrammatically in Fig. 4. During the first stage of the producer cycle, the temperature of the carbon is raised by passing air through it, in effect burning it, to form a gas of relatively low calorific power, according to the equation:



During the second stage of the process, the high-calorific-power water gas is produced, as indicated above, but only with a sacrifice of heat, the temperature of the fuel falling markedly during this stage.

The metals of relatively low chemical activity, lying below hydrogen, are found frequently uncombined in nature, and those lying below copper usually are reduced easily even if they are in an oxidized form, since only a limited amount of energy is required. Simple heating to temperatures as low as 250 F (120 C), even in the absence of a reducing agent, often may suffice, as in the well-known examples of the oxides of mercury and of silver:



From this brief discussion it can be seen readily that, in the reduction of metals from their ores under the usual conditions, the oxides of any impurities less active than the desired metal will tend to be reduced completely to the metallic state, whereas the oxides of any impurities more active than the desired metal will be affected only slightly, if at all, by the reduction process. This tendency often can be either decreased markedly or eliminated completely, however, by proper modification of the conditions of operation.

#### CHEMICAL ACTIVITY AND EASE OF OXIDATION

The more electropositive a metal is, the more easily will it tend to react with oxygen to form an oxide, with the evolution of energy. The oxide so formed may or may not adhere to and so protect the base metal, and the reaction may or may not proceed spontaneously to completion, depending upon other factors. However, if the oxide is not protective, the more easily a metal is oxidized the more apt the oxidation is to proceed to completion because the heat evolved automatically will increase the rate of the reaction.

All the metals more active than copper will oxidize with comparative ease on exposure to moist air. Those less active than copper do not, as a rule, oxidize readily under these conditions.

#### OXIDATION AND THE PURIFICATION OF METALS

These oxidation and reduction effects are of importance in the purification or refining of metals by any form of oxidation. Since the metals are usually molten, the impurities which are more active chemically than the desired metal can be eliminated by this means with a minimum of difficulty.

Those which are less active, however, are almost impossible to remove to any extent. The significance of this can be appreciated readily for a highly active metal, such as aluminum, the principal impurities in which are apt to be the less active elements, iron and silicon. In this instance, purification by oxidation alone would be impossible, so other treatments, usually purely chemical in nature, must be given to the ores before the metallurgical reduction takes place.

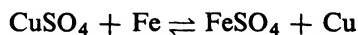
#### CORROSION AND CHEMICAL ATTACK

Chemical attack under conditions of service, or under similar conditions as reproduced or accelerated in the laboratory, usually is termed corrosion. It may or may not be accompanied by some form of mechanical wear or *abrasion*. The combination of corrosion and abrasion sometimes is referred to as *erosion*.

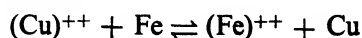
The prevention of corrosion and the protection of metals against it is of vital economic importance to modern industry. Protection usually is secured either by *physical* means, using inert or less active covering materials; or by *chemical* means, either by alloying and thus changing the chemical activity, by the use of coatings of greater chemical activity than the base metal, or by modifying the corroding conditions in some manner. On many metals, as on aluminum for example, the reaction product will adhere so tightly that it will, itself, protect against further attack. Under these latter conditions, the effects of mechanical erosion will be most marked, as by this means a new surface will be exposed constantly to attack.

The highly active alkali and alkaline earth metals will displace hydrogen from water even in the cold, and hence will be of little value in resisting corrosion unless the oxide formed adheres tightly to the metal and so protects it. Magnesium and the succeeding metals will displace hydrogen from steam. The electronegative metals lying below hydrogen will not displace it at all.

Any metal will tend to displace, in solution, another metal of lower chemical activity. Thus, if copper is in solution, and this solution is placed in contact with a more active metal such as iron, the iron will tend to replace the copper in solution. Simultaneously, the copper will be deposited upon the surface of the iron so the reaction:



will tend to stop as soon as the iron is covered completely. This reaction equally well might be written:



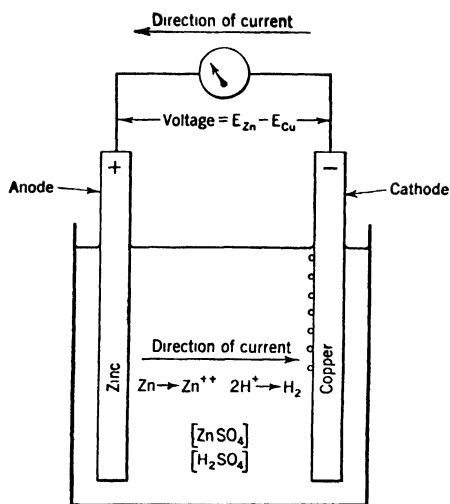
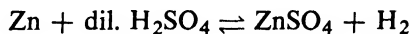


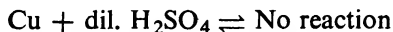
FIGURE 5. A simple galvanic cell.

Similarly, if two metals are placed in the same electrolyte and connected electrically, the more active (electropositive) one will tend to be dissolved in preference to the less active one, i.e., the more active one will tend to become the anode (positive electrode) of the cell. This is the principle of the simple galvanic cell (Fig. 5).

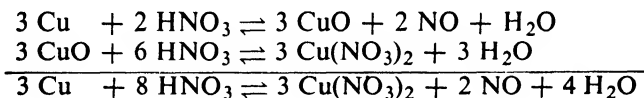
Metals more active than hydrogen react with hydrochloric acid (HCl) and dilute sulfuric acid (H<sub>2</sub>SO<sub>4</sub>) replacing the hydrogen:



but metals less active than hydrogen do not:



Metals more active than platinum react with nitric acid (HNO<sub>3</sub>) and with hot concentrated sulfuric acid (H<sub>2</sub>SO<sub>4</sub>), the acid first oxidizing the metal:



Even the most noble metals will be dissolved by *aqua regia*, a mixture of nitric and hydrochloric acids, although under some conditions, especially when the metal is very pure and free from strains, the rate of solution may be very slow.

#### EFFECTS OF TEMPERATURE UPON CHEMICAL ACTIVITY

An increase in temperature will, as is well known, tend to increase the rate of most chemical reactions. This effect, sometimes referred to as the *temperature coefficient of the reaction*, is, of course, significant in the selection of materials to resist corrosion. A given alloy might corrode so slowly at a low temperature as to be entirely suitable, and yet be attacked so rapidly at a higher temperature as to be useless.

In addition, there is some tendency for the elements to change their relative chemical activities with a change in temperature. Thus, in steelmaking, if the temperature of the molten metal is kept low, phosphorus may be oxi-

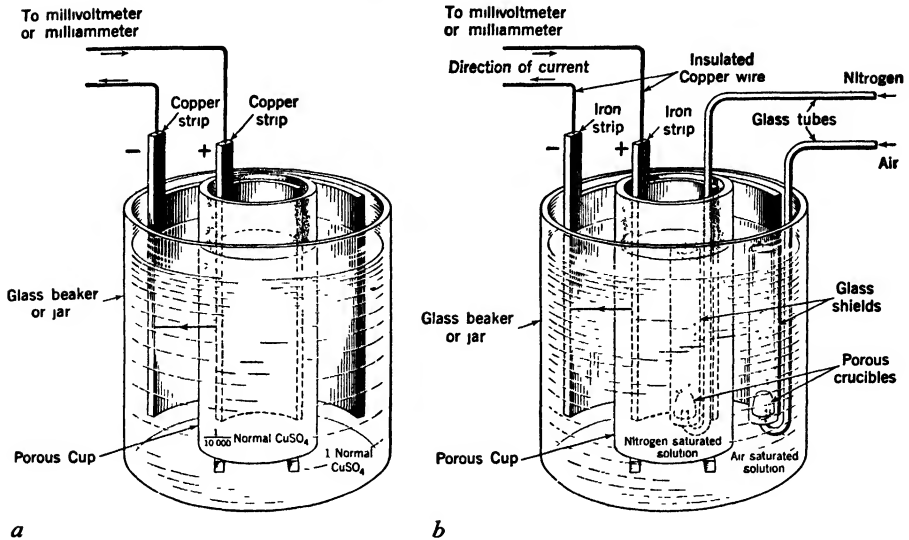


FIGURE 6a. Experimental metal-ion concentration cell. The current will flow from anode (+) to cathode (-) so the electrode in the weaker  $\frac{1}{10,000}$  normal solution will be much more attacked than the identical electrode in the stronger 1 normal solution. *b.* Experimental oxygen concentration cell. The current will flow from anode (+) to cathode (-) so the electrode in the nitrogen saturated solution will be attacked much more than the identical electrode in the air saturated solution. (From *Nickel and Nickel Alloys*, courtesy The International Nickel Company, Inc.)

dized before carbon, whereas at a higher temperature the reverse is true. The effect this has on steelmaking practice will be seen better later.

#### EFFECTS OF PRESSURE UPON CHEMICAL ACTIVITY

External pressures may have effects similar to, although generally much smaller than, those of temperature, changing either the rate of reaction or the chemical activity of the metals involved.

More important, however, are the effects of internal pressures, especially those produced by mechanical strain and usually referred to under the general name of *internal stresses*. In the loading of structural members, for instance, different portions may be strained to different amounts. Because of these differences, they will tend to corrode differently, the more highly strained portions usually tending to be anodic to the less strained sections, although this relationship is by no means general and often is complicated by other factors.

#### EFFECTS OF CONCENTRATION UPON CHEMICAL ACTIVITY

Either the resisting metal or the corroding solution may be affected by concentration changes. Variations in alloy content may change the cor-



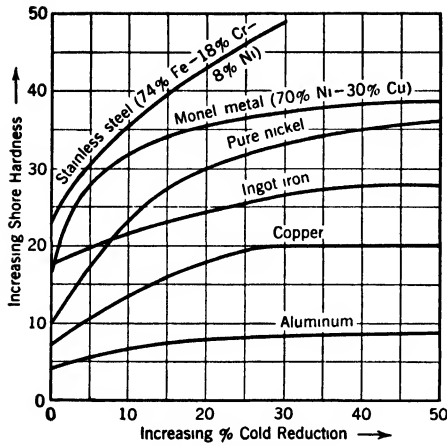


FIGURE 7. Increase in Shore hardness of various metals and alloys with cold-working. (Courtesy The International Nickel Company, Inc.)

rosion resistance markedly, either increasing or decreasing it, depending upon the nature and chemical activity of the alloy formed. Likewise, inhomogeneities, either in composition or in structure, in any given alloy may have an appreciable effect on its resistance to corrosion.

On the other hand, if two pieces of an identical metal are connected electrically and then immersed in two interconnected solutions, differing either in nature or in concentration (Fig. 6a), it will be found that one electrode will tend to become anodic to the other, and thus tend to corrode preferentially.

Which piece is affected, of course, will depend upon the chemical activity of the metal with respect to the particular solutions selected. Differences in oxygen concentration, such as would be found between water at and below the water-air surface, exemplify this effect. It is sometimes very confusing to find the heavier corrosion well below instead of at the water-air surface, but the reason for it, as indicated in Fig. 6b, is not difficult to understand.

## *Mechanical Properties*

### WORK-HARDENING

The ability of the metallic materials to be hardened and strengthened by mechanical deformation is probably the most important of all the metallic characteristics.

The application of a stress to a metallic material will tend to deform it. The resulting strain can be either *elastic*, in which case it is very nearly proportional to the stress and will disappear completely in time when the stress is removed, or *plastic*, producing thereby a permanent deformation. Within certain temperature ranges, the metal will be hardened and strengthened by any permanent deformation, as indicated in Fig. 7 for several metals and alloys, and thus will be able to sustain greater loads than it could before it was strained. This effect is known as work- or strain- hardening, and since it is related uniquely to the metallic type of atomic structure, it probably will

never be found or produced in any other type of material.<sup>3</sup> Somewhat similar effects have been found in certain rocks and crystals, but they are fundamentally different in nature.

Fortunately, at normal atmospheric temperatures, most metals and nearly all commercial alloys are susceptible to strain-hardening. Were this not so, the metallic materials probably would be of much less importance than they are in our everyday life.

#### ENGINEERING EFFECTS OF WORK-HARDENING

It is largely because of the characteristic of work-hardening that metals are of such great value in all phases of engineering, although many engineers still continue to believe that once metal in a structure undergoes any permanent set, it becomes useless. Actually, of course, as long as any structural member continues to function satisfactorily, it still is undamaged as far as the user is concerned.<sup>4</sup>

If a sufficiently large load is applied to a nonmetallic material in which any defect exists, it will be found that the stress will tend to concentrate at the defect and cause it to be propagated rapidly until fracture occurs. Metallic materials which work-harden only slightly, if at all, will behave similarly, failing rapidly and with little or no deformation once plastic yielding begins. Such materials are said to be *brittle*.

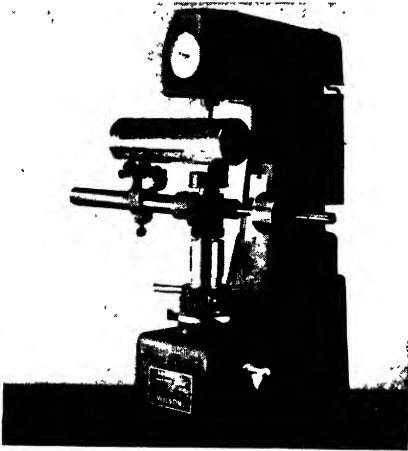
On the other hand, metals that work-harden are said to be *tough* because they first will resist the deformation by work-hardening instead of failing at once. Thus, a defect in such a material will be protected, in a sense, by the work-hardening and strengthening of the metal around it so that propagation will not proceed until the material has undergone the maximum amount of work-hardening. Because of this, in practically all applications in which work-hardening is possible, a slight overload actually will strengthen the material and make it more resistant to further deformation. This statement does not imply, naturally, that such overloading is desirable, rather, that in many cases the metallic materials can, and frequently do, withstand appreciable overloading without harmful effect.

#### FACTORS AFFECTING WORK-HARDENING

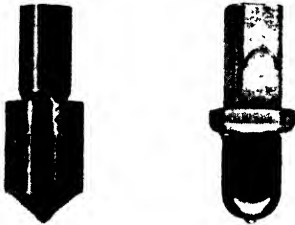
Work-hardening is a complex phenomenon and as yet no entirely satisfactory explanation of it has been found. Hence, it is much more helpful to

<sup>3</sup> That this statement is not strictly true is shown by the recent work of K. L. Fetters and M. Dienes on silver chloride, *Trans. A.I.M.E.*, **154**, 1943, 262.

<sup>4</sup> H. F. Moore, *Proc. A.S.T.M.*, **39**, 1939, 549-570, discusses this further.



The Rockwell hardness tester



Brale (left), ball (right) penetrators

FIGURE 8a. The Rockwell hardness test. (Courtesy Wilson Mechanical Instrument Co., Inc.)

In the normal "Rockwell" hardness tester the minor load is 10 kg, the major loads 60, 100, or 150 kg, and either a Brale or a ball penetrator may be used. The reference point for all readings is at the point on the scale marked "Set." This point is at 30 on the B (red) scale, rather than at 0 as on the C (black) scale, in order to avoid negative readings on the softer materials with which the ball penetrator is used more commonly. The combinations used most frequently are:

Rockwell Scale	Major Load, kg	Penetrator	Scale Color
A	60	Brale	C (black)
B	100	$\frac{1}{16}$ in. Ball	B (red)
C	150	Brale	C (black)
D	100	Brale	C (black)
E	100	$\frac{1}{8}$ in. Ball	B (red)
F	60	$\frac{1}{16}$ in. Ball	B (red)
G	150	$\frac{1}{16}$ in. Ball	B (red)
H	60	$\frac{1}{8}$ in. Ball	B (red)

Thus a reading of 68 on the B (red) scale secured with a 60 kg load and a  $\frac{1}{16}$  in. ball penetrator would be reported as Rockwell hardness F68; and a reading of 65 on the C (black) scale secured with a 150 kg load and a Brale penetrator would be reported as Rockwell hardness C65.

For thin specimens or metal with a shallow, hard surface a special *Superficial* hardness tester, having a 3 kg minor load, major loads of 15, 30, or 45 kg, and using either a Brale (N) or a  $\frac{1}{16}$  in. ball (T) penetrator, is used. A reading of 40 secured with a 30 kg load and a Brale penetrator would be reported as Rockwell Superficial hardness 40 (30N). The gauge scale on both machines is reversed so that, in conformity with custom, high hardness numbers mean a shallow indentation and thus a hard material.

The greatest hardness that can be tested is limited only by the ability of the diamond penetrator to withstand the stress. For very low hardnesses the larger diameter balls frequently must be used and constant test times also are often necessary to limit material flow. Specimens to be tested must be smooth on both sides, clean, and thick enough that no impression, called the *anvil effect*, shows on the underside.

When testing curved surfaces greater than  $\frac{1}{2}$  in. in diameter little error is introduced by the curvature but for smaller rounds the diameter always should be specified as well as whether the test was made on a flat or a round surface. When close hardness tolerances are important and must be related to readings on flat surfaces, a correction should be applied.

Great care must be used in trying to relate differences in hardness on any of the scales because one point near the high side of any scale signifies a hardness difference considerably greater than one point near the middle or low range of the scale. Different scales may overlap in certain regions but outside of such regions they cannot be compared satisfactorily. Hardness conversions between different scales also are not always the same for different materials.

Note The scale of the dial is reversed so that a deep impression gives a low reading and a shallow impression a high reading, in this way a high number means a hard material. The "set" position is at 30 on the "B" (red) scale which is used with the ball penetrator.

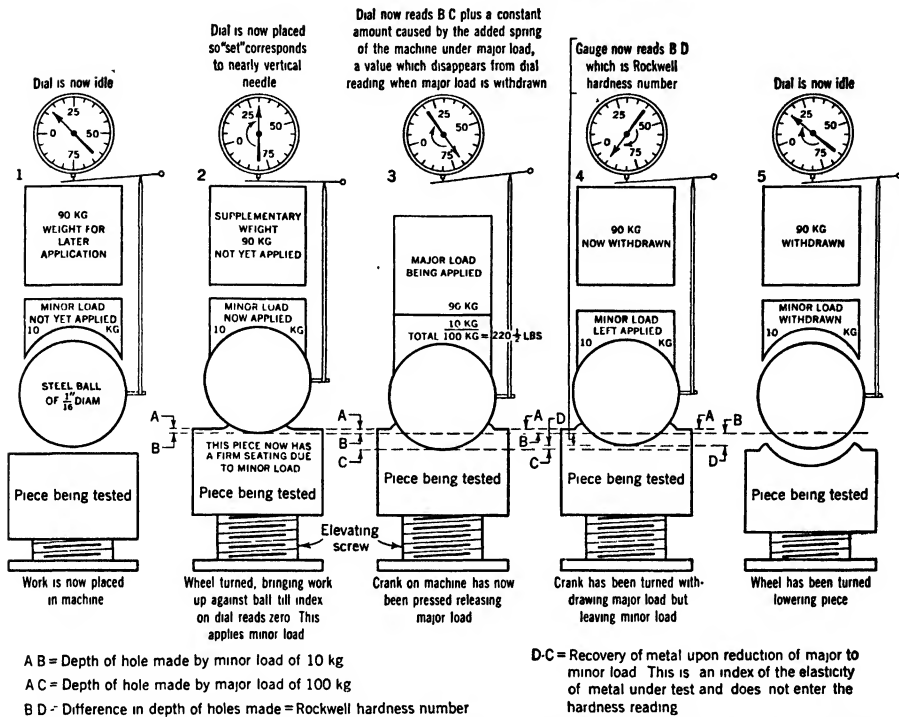


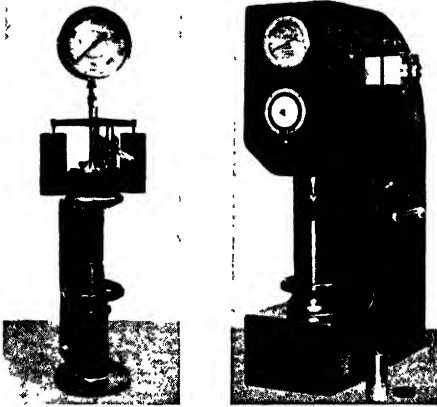
FIGURE 8a (continued). Principle of operation of the Rockwell hardness tester (B scale).

discuss its effects on physical properties rather than its basic cause. However, it is known that work-hardening is affected by several factors, among which may be mentioned: (a) the dominant metal; (b) the alloying element or elements and their concentration; (c) the temperature; (d) the type, rate, and amount of deformation. In any given alloy, it will be found that the rate of work-hardening will decrease as the percentage reduction in thickness or area is increased. This can be seen readily from the typical curves shown in Fig. 7. In each case the slope decreases as the percentage reduction increases.

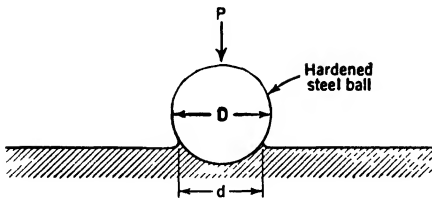
HARDNESS OR RESISTANCE TO PENETRATION

Hardness is measured in a number of different ways.<sup>5</sup> Three of the most common methods, the *Rockwell*, *Brinell*, and *Vickers diamond pyramid*

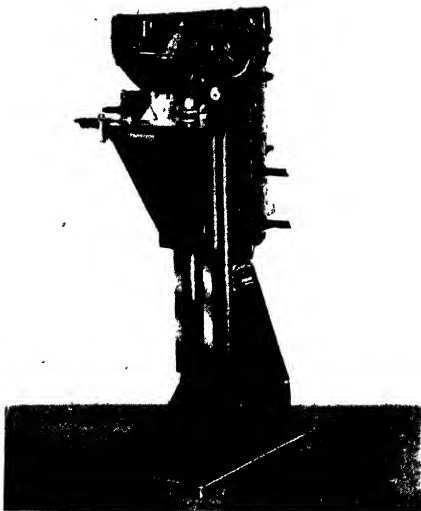
<sup>5</sup> For a more complete discussion see *The Hardness of Metals and Its Measurement*, by H. O'Neill: The Sherwood Press, Cleveland, Ohio, 1934.



Manual (left), motorized (right), Brinell hardness testers



Impression made in specimen by Brinell ball



Vickers hardness tester

FIGURE 8b. The Brinell hardness test. (Courtesy Tinius Olsen Testing Machine Co.)

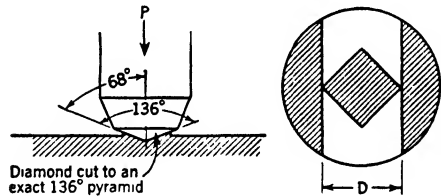
For ferrous materials  $\frac{P}{D^2} = 30$ , with  $P = 3000$  kg and  $D = 10$  mm, applied for 30 sec in the standard test. For nonferrous materials  $\frac{P}{D^2} = 5$ , with  $P = 500$  kg and  $D = 10$  mm, applied for 60 sec in the standard test.

$$B_{hn} = \frac{\text{Load in kg}}{\text{Area of spherical impression in sq mm}}$$

$$= \frac{P}{\frac{\pi D}{2} (D - \sqrt{D^2 - d^2})}$$

Specimens, preferably, should be at least  $\frac{1}{2}$  in. thick and fairly large.

FIGURE 8c. The Vickers hardness test. (Courtesy Riehle Testing Machine Division, American Machine and Metals, Inc.)

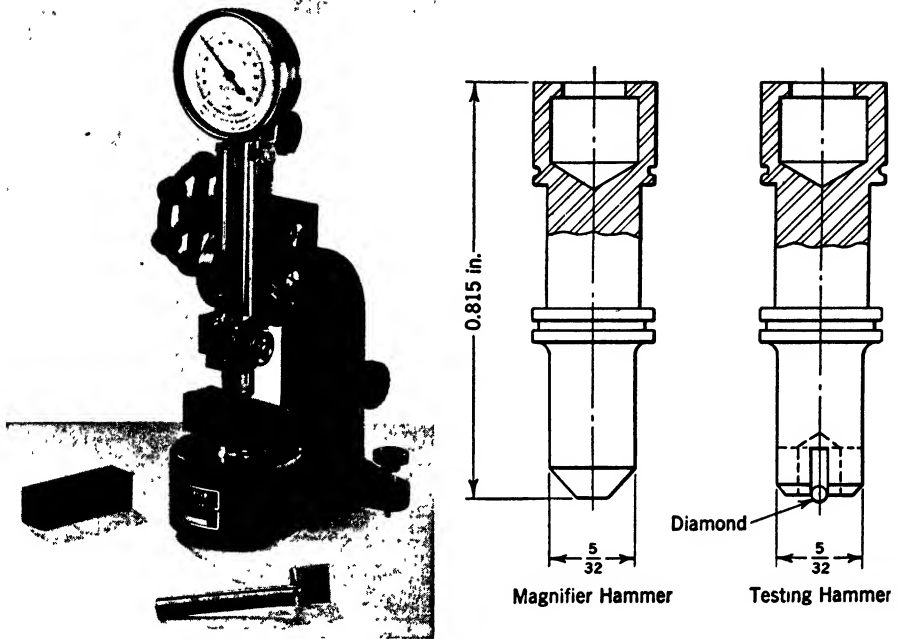


Cross-section (left), surface (right) Vickers hardness impression (schematic)

$$V_{hn} = \frac{\text{Load in kg}}{\text{Lateral area of pyramidal impression in sq mm}}$$

$$= (2 \sin 68^\circ) \frac{P}{D^2} = 1.854 \frac{P}{D^2}$$

Vickers hardness numbers are practically independent of the load which may have any value from 1 to 120 kg, and is applied for 10 sec. The test, therefore, may be used successfully with almost any type or thickness of material. A polished surface is preferable, however.



#### Shore scleroscope

FIGURE 8d. The Shore scleroscope hardness test. (Courtesy Shore Instrument Manufacturing Co.)

The height of rebound of a small diamond hammer, of definite weight and falling from a definite height, is measured either by visual observation or on a recording dial. The constants involved depend on the model instrument used but the principle of all of them is identical. The scale used is arbitrary, determined by considering the rebound from quenched pure high-carbon steel to be 100 and dividing it into 100 equal divisions. Almost any thickness specimen may be used, but a smooth surface is essential. Practically no mark is made on the specimen. For soft materials a special magnifier hammer is used. The instrument can be used in a portable manner provided the clamping pressure on the specimen is kept constant, and the mass of the specimen is at least as large as that of the usual anvil.

hardness testers, impress either a diamond cone, a hardened steel ball, or a diamond pyramid into the material being tested, under a definite load and for a definite time. The general nature of these three types of tests is illustrated in Fig. 8. The hardness number either is read directly on a dial gauge, or else determined by reference to tables based upon either the diameter, depth, or depth increment of the impression for the test conditions used.

A fourth method, the *Shore scleroscope*, purports to measure the amount of energy that is expended in deforming the specimen elastically, as indicated by the rebound of a small hammer of definite weight when dropped from a definite height on to the specimen surface. This is, therefore, more nearly a dynamic hardness test, which probably produces less work-hard-

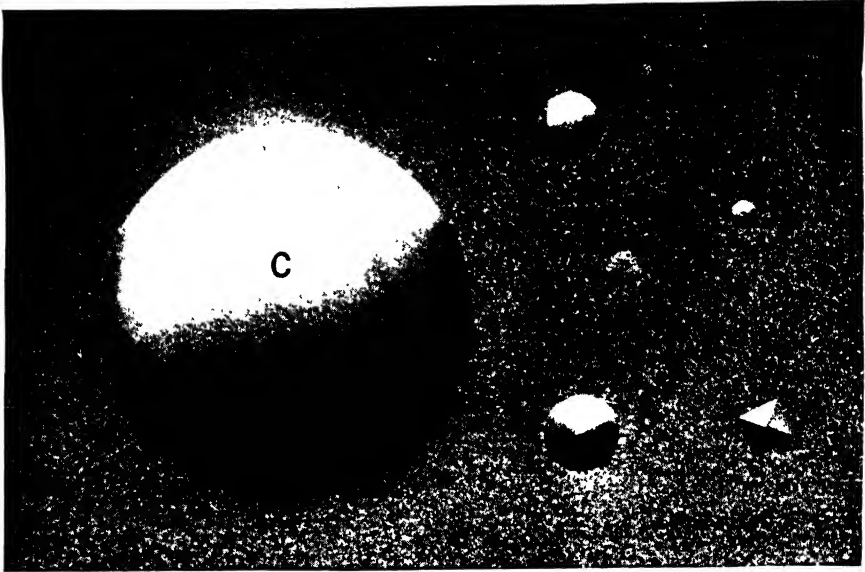


FIGURE 8e. Hardness-test impressions of six different hardness testers. Enlarged to approximately  $6\frac{1}{2}$  diameters.

A. Vickers

B. Rockwell "C"

C. Brinell

D. Monotron

E. Scleroscope

F. Rockwell "B"

(Courtesy H. B. Pulsifer, Ref. 2 at the end of this chapter.)

ening, and hence measures a somewhat different type of penetration hardness than that measured by the other three tests, although there is some relationship between values secured by all four methods.

A comparison of some of the commonly used hardness scales is shown in Fig. 9. *These relationships are only approximate, and should not be used on any other basis.*

Still other methods of hardness testing use various systems of scratch hardness, either relative or in comparison with arbitrary standards, and sometimes even such widely different properties as wear or abrasion resistance, cutting ability, and machinability, are referred to as *hardness*.

In all of these tests, work-hardening occurs to some extent, even though much effort has been directed toward eliminating or minimizing it by modifications in design. In all of them the material being tested is constantly changing during the test. No values so secured can be absolute and, in reality, they measure some combination of the actual hardness and the hardness increase resulting from the work-hardening since the two are practically inseparable.

Since hardness seldom is determined for its own sake and usually is an index of some other more complex and elusive property such as strength, workability, or machinability, it always must be remembered that it is truly

significant only when used as a comparison between similar materials of correct dimensions and in more or less comparable conditions. As a simple, easily made test, especially for control purposes, hardness tests have a definite and important place in industry.

In general, the purer a metal is, the lower will be its hardness, alloys tending to be not only inherently harder than the metals upon which they are based, but also more susceptible to changes in hardness caused by mechanical work or heat-treatment. No alloy has been developed as yet which is as hard as the diamond, the hardest material known, but certain carbide tool materials approach it.

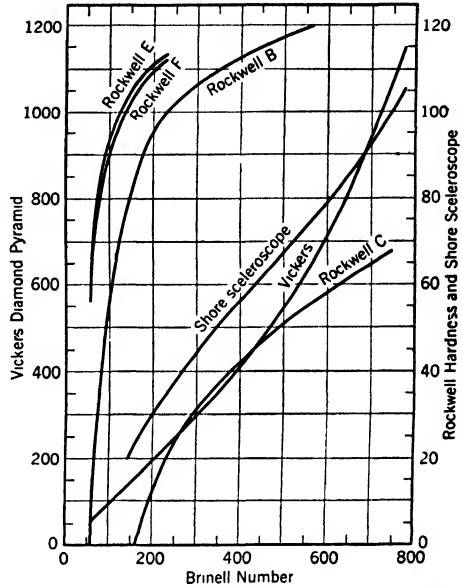


FIGURE 9. Approximate relationships between several of the commonly used hardness scales.

The hardnesses of the eight engineering metals in the soft condition are all quite low, and in addition are subject to considerable variation. Consequently, they are of interest only in a relative sense. For simplicity, only the approximate average Brinell hardness numbers (Bhn), as determined from the indentation of a 10-mm diameter ball applied for 60 sec under a load of 500 kg, are given in Table III.

TABLE III APPROXIMATE HARDNESS OF THE ENGINEERING METALS

	BHN		BHN
<i>Nickel</i>	80	<i>Aluminum</i>	25
<i>Iron</i>	75	<i>Magnesium</i>	20
<i>Copper</i>	40	<i>Tin</i>	14
<i>Zinc</i>	35	<i>Lead</i>	8

From an engineering viewpoint the data in Table III have little if any significance, however, since none of these metals is apt to be used in the soft condition for applications in which hardness has any importance. Further-



more, readings on actual specimens may vary over a comparatively wide range.

#### STRENGTH OR RESISTANCE TO DEFORMATION

The strengths of metals and alloys generally will parallel their hardnesses. With proper treatment, wires of some metals, such as tungsten, have developed strengths as high as 500,000 psi, but even this is far below the strengths found in some other materials, such as certain glass fibers, for example. Practically, about 250,000 psi seems to be the maximum strength attainable in commercial metallic materials; and even such values seldom are realized because of weaknesses or deficiencies in other respects.

Of the engineering metals, it generally will be found that alloys based upon iron or nickel are apt to be the strongest; that those of copper, aluminum, or magnesium occupy intermediate positions; and that those of lead, tin, or zinc are of comparatively low strength. Where weight or load-carrying capacity is important, the relative positions of the alloys of the light metals, aluminum and magnesium, are improved markedly because of their lower specific gravities.

In no test is the rate of work-hardening so important as in the tensile test which is used most frequently to determine strength. If such a test is made under dead loading, the rate of deformation will be determined by the other test conditions. In a majority of these tests, however, a machine imposes a deformation upon a test specimen at a controlled rate, and the pressure required to produce this deformation, or to maintain this rate, determines the load indicated by the machine as exerted upon the specimen. Since the amount of work-hardening is affected to some extent by the rate at which it occurs, the speed of testing must be controlled carefully if reproducible results are to be secured.

Only three ranges of testing rates will be discussed here as they cover most of the phenomena encountered: (a) very rapid deformation, as in the impact test; (b) intermediate rates of deformation, such as are encountered in the usual tensile test; and (c) slow rates of deformation, such as those occurring in creep and relaxation.

#### IMPACT STRENGTH

In certain applications, most of the failures are believed to result from some form of impact. In such cases, therefore, *impact tests*<sup>6</sup> are very important. As a general rule, however, impact testing of full-size specimens is impractical; such tests must be confined to relatively small specimens, which

<sup>6</sup> See, for a more complete discussion, "Symposium on Impact Testing," *Proc. A.S.T.M.*, 38, II, 1938, 21-156.

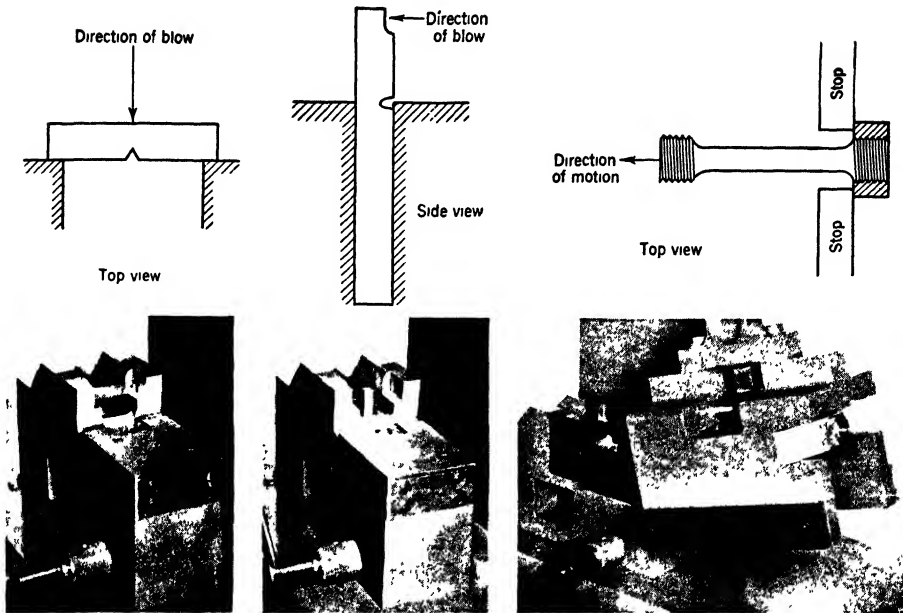


FIGURE 10. Principle of the Charpy (left), Izod (center), and tensile (right) impact tests. (Photographs courtesy Tinius Olsen Testing Machine Co.)

may or may not be comparable. The impact test assumes that the resistance of a material to shock depends on its ability to equalize concentrated stresses safely and rapidly. Usually data so secured must be measured and recorded only in terms of the energy absorbed in causing fracture, simply because the intensity and distribution of the stress during the test are too complex to be analyzed satisfactorily. On this basis, a brittle material would, as a rule, tend to absorb less energy than a tough one, although the results are by no means so simple to interpret as this statement might indicate.

Two methods of impact testing, the *Charpy* or simple beam, and the *Izod* or cantilever beam, have been used most widely although no complete standardization has been made yet. The differences between the two are indicated in Fig. 10. In both tests, a single blow is struck by a falling pendulum. Since this pendulum has a definite weight, is released from a fixed height, and swings downward in a vertical plane, its energy, when it strikes the specimen at a definite position as it passes through the lowest point in its travel, is quite reproducible. The energy remaining in the pendulum after it strikes and breaks the specimen will be used in carrying the pendulum up a certain distance in its swing. Consequently, by measuring the difference in the angle of rise when the pendulum swings free and when it



FIGURE 11. A modern impact testing machine readily adaptable for Charpy, Izod, or tensile impact testing. The hammer is set for an Izod test. (Courtesy Timmus Olsen Testing Machine Co.)

has broken a specimen, the energy absorbed in breaking the specimen may be determined.

The Charpy test employs a specimen which is a simple horizontal beam supported at the ends. Frequently, the specimen is notched in a characteristic manner to concentrate the stress. In the Izod test, on the other hand, the specimen is clamped on one end in a vertical position, and acts as a cantilever beam. The Izod specimen also may be notched.

The notches have an embrittling effect because they concentrate the stress and, hence, are extremely useful, if not necessary, in making comparative tests on specimens of fairly tough materials. Without the notch,

these simply bend in the machine, and the energy required for rupture cannot be obtained. However, the use of a notch likewise eliminates the results as far as design work is concerned because, in engineering design, it is invariably desired to get as far away from notch effects as possible.

The impact test also indicates the total energy to produce fracture, a value which would have little significance in correct engineering design in which the allowable loads are kept well below those which would produce any permanent set at all. Correlations have been made between service failures and low impact strengths, and the tests appear to have some significance in the comparison of generally similar materials, such as different types of steels, and in determining abuses in treatment.

Most modern Charpy and Izod machines, such as the one shown in Fig. 11, also are equipped for *tensile impact* testing (Fig. 10 *right*). In tensile impact, a pure tensile loading is applied suddenly by stopping one end of the specimen at the bottom of the pendulum swing, while the other end remains rigidly attached to the back of the pendulum.

The Carpenter or Luerssen-Greene *torsion impact tester*<sup>7</sup> (Fig. 12) which was developed primarily for testing hard steels and brittle materials such as tool alloys, is a relatively new addition to the impact tests. In the torsion impact test, the specimen is clamped at one end and the other is engaged with a head, rotating at a definite speed, which twists it until it breaks. The

<sup>7</sup>G. V. Luerssen and O. V. Greene, *Proc. A.S.T.M.*, 33, 11, 1933, 315-333.

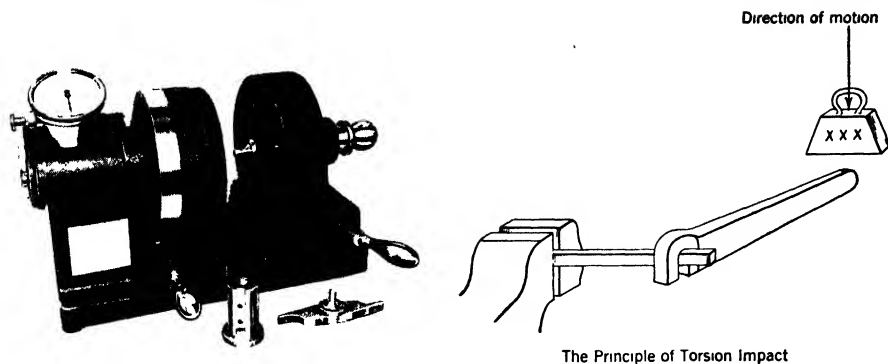


FIGURE 12. A modern Carpenter (Luerssen-Greene) torsion impact tester (*left*) for use with hard steels (courtesy Baldwin Southwark Division, The Baldwin Locomotive Works); and a schematic sketch (*right*) illustrating the basic principle of torsion impact. (From *Tool Steel Simplified* by F. R. Palmer, courtesy The Carpenter Steel Company.)

change of speed of the rotating head is used to compute the energy absorbed. In the usual impact tests on brittle materials, with either notched or unnotched specimens, results tend to be inaccurate and misleading. Torsion impact, by loading the entire cross section at the same time, gives much more significant data.

#### TENSILE STRENGTH

The ordinary tensile test<sup>8</sup> is used to secure information on both the elastic and the plastic properties of the material.

When a specimen is stressed in tension it will elongate. If it is at all elastic, the strain will be proportional to the stress, as shown by the first portions of the curves in Fig. 13, i.e., the material will obey *Hooke's law*. Actually, an exact straight-line relationship between stress and strain probably never occurs, but the law is a very close approximation for many materials in the correct ranges of stress, and the deviation from a straight line can be detected only with the most precise instruments.

As the load is increased, a stress will be reached to which the strain is no longer proportional. If the specimen is stressed above this point, and the load then released, it will be found that it has suffered a permanent set or deformation. This point, therefore, is the *elastic limit*, the maximum unit stress that can be developed in a material without causing a permanent set. To avoid subsequent confusion, it must be emphasized that, strictly, *the elastic limit can be determined only by successively loading and unloading a specimen until a load is reached for which a permanent measurable set results*. As this value is extremely laborious to determine, it is seldom secured al-

<sup>8</sup> See, for example, C. W. McGregor, *Proc. A.S.T.M.*, 40, 1940, 508-534; A.S.T.M. Standard E8.

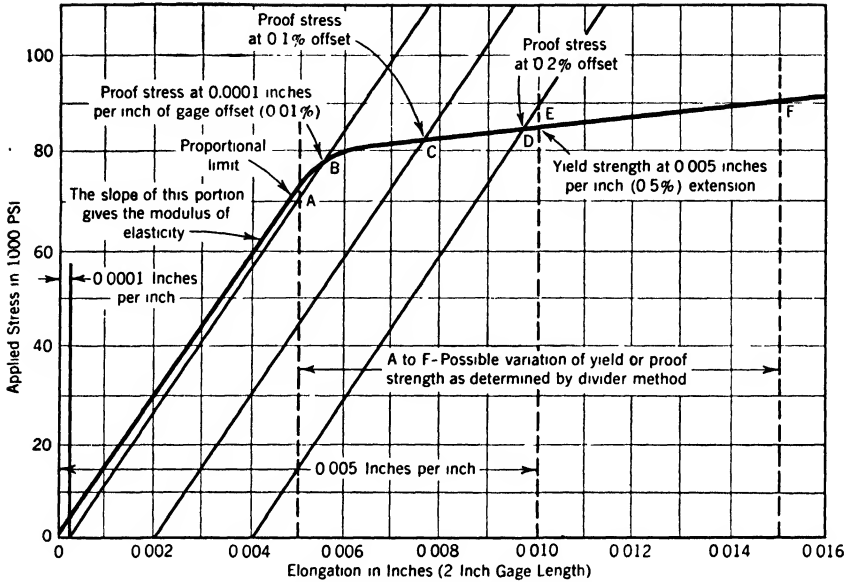


FIGURE 13. Initial portion of typical stress-strain curve for cold-drawn steel showing method of determining various values. Since the *elastic limit*, by definition, depends on the permanent set after successive reloadings, with complete release of load each time, it cannot, strictly, be shown on such a diagram.

though the term elastic limit sometimes is used loosely in referring to other points on a load-extension or stress-strain curve.

With accurate devices for measuring strain, it is possible to detect a point close to but below the elastic limit at which there is a deviation from Hooke's law, but no apparent set. This point is called the *proportional limit*, the maximum unit stress for which the unit strain increases at the same rate as the unit stress.<sup>9</sup> In a strict sense, neither the elastic limit nor the proportional limit is used commercially. The exact value of either of them will depend, to a large extent, on the accuracy of the measuring instruments used to determine the unit strain, and on the frequency with which readings are taken.

#### MODULUS OF ELASTICITY

Within the range of stress for which Hooke's law is valid, the slope of the stress-strain curve, i.e., the ratio of the unit stress to the unit strain, gives what is called the *modulus of elasticity* of the material being tested. This may be expressed as:

$$E = \frac{P/A}{e/L} = \frac{PL}{Ae}$$

<sup>9</sup> See R. L. Templin, *Proc. A.S.T.M.*, 29, II, 1929, 523.

where  $E$  is the modulus;  $P$  the load;  $A$  the cross-sectional area;  $e$  the elongation or the change in length produced by the application of the load; and  $L$  the original length.

Moduli of elasticity are of importance in engineering design because they determine the stiffness of a given material, and hence influence strongly the section shapes, the unsupported spans, and the other factors in which this value must be considered. The modulus of elasticity is determined almost entirely by the dominant metal in the alloy. It is changed somewhat by alloying but only to a small extent by mechanical or thermal treatment. Approximate values for the engineering metals are given in Table IV.

TABLE IV MODULI OF ELASTICITY OF THE ENGINEERING METALS

	E IN PSI		E IN PSI
<i>Nickel</i>	30,000,000	<i>Aluminum</i>	10,000,000
<i>Iron</i>	30,000,000	<i>Magnesium</i>	6,250,000
<i>Copper</i>	16,000,000	<i>Tin</i>	6,000,000
<i>Zinc</i>	14,000,000	<i>Lead</i>	2,500,000

Since the addition of alloying elements in moderate amounts has little effect on the modulus of elasticity, these values are also approximately applicable to most of the engineering alloys of these metals.

#### PLASTIC DEFORMATION

Increasing the load above the elastic limit results in a permanent deformation of the specimen. The first section to be so deformed will, of course, be the weakest one. It will be strain-hardened and strengthened as a result of its deformation until it can sustain the load. The next weakest section will then have to bear the load, and it will deform and be work-hardened, in a similar manner, until it also can sustain the load. As this progressive strengthening continues, the specimen will be continually elongating.

The unit stress for which the elongation reaches some arbitrarily specified value, frequently 0.1–0.2% of the gauge length, is termed the *yield strength* of the material. The extension for which the yield strength is determined is empirical, and does not seem to be particularly well standardized in all alloys, so some caution must be exercised in comparing the values for different materials to be sure they are determined on the same basis.

Sometimes, also, the term *proof stress* or *proof strength* is used. By definition, this is the unit stress which a material is capable of withstanding

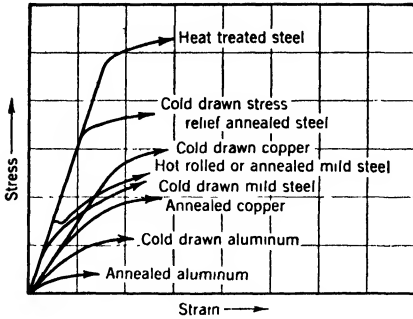


FIGURE 14. (Left) Initial portion of stress-strain curves for aluminum, copper, and steels in various conditions. Note that the higher moduli of elasticity give steeper initial slopes to the curves.

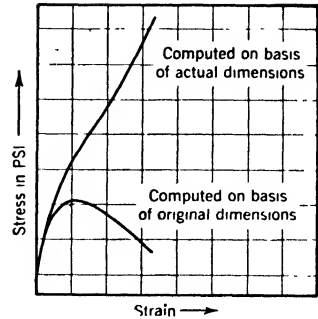


FIGURE 15. (Right) Comparison of stress-strain curves for mild steel in which the stress is plotted, both from original specimen dimensions and from actual specimen dimensions during test, against the strain (elongation). (After C. W. MacGregor, *Trans. A.I.M.E.*, 124, 1937, 208-226.)

without undergoing a permanent deformation, either after complete release of the load, or, as determined by the offset method, of more than a specified amount.

With some ductile materials, or after certain thermal or mechanical treatments, there is still another point called the *yield point* which may be defined as the unit stress at which the material continues to deform without an increase in load. In many materials, this is manifested by an apparent decrease in the load measured by the testing machine, e.g., the so-called drop of the beam, as shown in the curve for annealed steel in Fig. 14. However, it must be remembered that the testing machine is imposing a strain on the specimen at a definite rate, and if the load indicated suddenly decreases, it simply means that the specimen is momentarily yielding at a faster rate than the machine is elongating it. With a dead load, naturally, there could be no decrease in the load although a sudden increase in the rate of elongation would be noted.

Very few materials exhibit a true yield point. Hence, the proportional limit and yield strength are much more significant values, even though the actual magnitude of the former depends on the sensitivity of the measuring device used to record the elongation, and that of the latter on a more or less empirical elongation value. Values of yield strength are the ones most widely quoted, although they may be labeled incorrectly.

#### THE ULTIMATE STRENGTH

On continued application of the load, the specimen, unless it is a brittle material, will elongate further with concomitant work-hardening until a

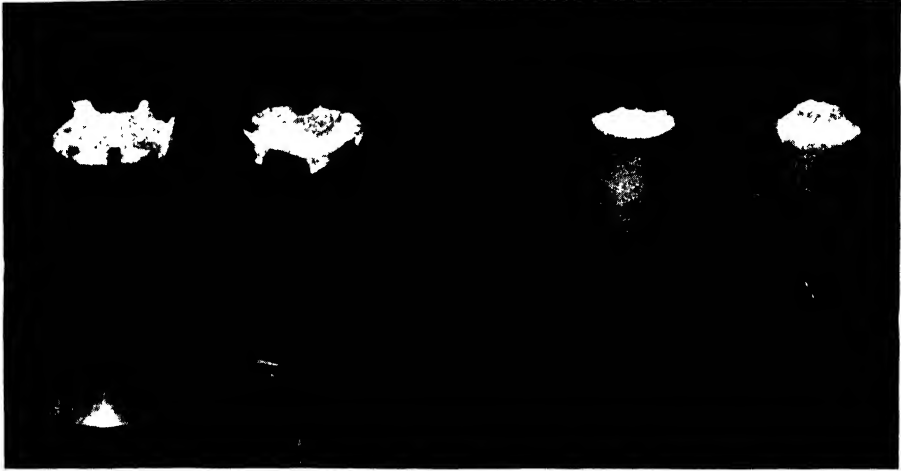


FIGURE 16. Typical brittle (*left*) and ductile (*right*) fractures secured in tensile tests of  $\frac{1}{2}$ -in. diameter brass rod. (Courtesy Technical Department, The American Brass Company.)

load is reached at which some section is unable to strain-harden rapidly enough to support the load. All of the load will then be concentrated on this section which will elongate rapidly, decreasing in cross-sectional area by *necking down*, until fracture occurs.

In the usual stress-strain or load-extension curve, the original cross-sectional area is considered to remain essentially unchanged throughout the test. As soon as the section begins to neck down, therefore, the stress will apparently decrease. The magnitude of the unit stress at this maximum point is known as the ultimate tensile strength of the material. However, if the actual cross-sectional area is used instead of the original value, as in Fig. 15, it will be found that the unit stress increases continually until fracture occurs at the breaking stress. The ratio between the ultimate tensile strength as determined from the original cross-sectional area and the actual breaking strength as determined from the actual cross-sectional area gives a satisfactory method for evaluating the work-hardening capacities of different metals. However, a better value might be secured, although with somewhat more effort, by using the yield strength as the initial or base value rather than the ultimate tensile strength because this would include all instead of only part of the plastic deformation the specimen undergoes.

#### ELONGATION AND REDUCTION IN AREA

In addition to the data on strength, some idea of the *workability* of the material can be secured from the tensile test<sup>10</sup> by measurement of the *per-*

<sup>10</sup> See H. W. Gillett, *Proc. A.S.T.M.*, 40, 1940, 551-578.



*centage elongation* and the *percentage reduction in area* after the specimen has broken. For brittle materials which have a fracture similar to that shown at the left in Fig. 16, both of these values will be low, of the order of a few per cent at most. However, for materials that are tough and workable, values of 50% or higher are common, with a fracture similar to that shown at the right in Fig. 16 and sometimes called a *cup and cone* fracture.

Two terms are used commonly in speaking of workability: *ductility*, the ability to be drawn into fine wires; and *malleability*, the ability to be beaten or compressed into thin foil. Although the two are not identical, because ductile materials must have a certain strength that malleable materials need not necessarily possess, they both are used loosely in the same sense.

Workability is a property which generally opposes hardness and strength. Thus, the pure metals which tend to have lower hardnesses and strengths usually will be quite workable, and a simple qualitative test for purity can be based upon the excellence of this property. On the other hand, alloys which are very strong and hard are apt to be brittle or to have little, if any, workability. The majority of the engineering alloys will, of course, be intermediate in nature, having varying combinations of the two properties.

#### COMPRESSIVE STRENGTH

Compression tests<sup>11</sup> are also of importance, especially for brittle materials which fail in shear. In such materials, the ultimate compressive strength is easy to determine since the specimens shatter when failure occurs. However, with ductile materials there is no definite value for the compressive strength. Comparison of ductile materials in compression, therefore, can be made best by setting a definite limit for the deformation, and by comparing the loads required to cause this deformation.

A *modulus of elasticity in compression* also can be computed by a method similar to that used in tension. Usually, the two values will be found to check closely.

#### EFFECT OF TESTING SPEED UPON TENSILE DATA

The term speed of testing is used not only with reference to the rate of elongation (movement apart of the jaws of the testing machine), but also to the rate of load application. Consequently, to avoid confusion, the intended meaning always should be specified. It has been proved repeatedly<sup>12</sup> that the manner in which the test is run will affect the results. Although the

<sup>11</sup> See A.S.T.M. Tentative Standard E9-T.

<sup>12</sup> See, for example, P. G. Jones and H. F. Moore, *Proc. A.S.T.M.*, 40, 1940, 610-624; *ibid.*, 41, 1941, 488-491; L. H. Fry, *Proc. A.S.T.M.*, 40, 1940, 625-636.

ultimate strength of ductile materials in tension is changed little by an increase either in the rate of elongation or in the rate of loading, the yield values may be increased as much as 10% and the percentage elongation decreased appreciably.

The ultimate strength in compression of both ductile and brittle materials, on the other hand, is apt to be altered considerably when the speed is increased. For best results, standard testing methods, such as those recommended by the American Society for Testing Materials, should be used; and the speed of testing should be recorded and defined along with the values secured.

#### EFFECT OF SIZE OF SPECIMEN

Most tensile and compressive tests are made upon standard size specimens. However, it has been found frequently that full-size members<sup>13</sup> do not give comparable results, possibly because the stresses are much more complex than had been anticipated by the design. This is especially true in riveted structures. Hence, there is a growing tendency on the part of some engineers to test either full-size or scale specimens, especially in those instances in which structures are so complex as to be almost indeterminate, or in which factors of safety must be kept to a minimum, as in the fields of aeronautics and motor transportation, where tests on full-size models or parts of actual units are common practice during the preliminary stages. If a proper correlation between the full-size and the standard specimens can be made, it would, of course, be less expensive and more satisfactory to use the latter. However, it is usually almost impossible, with standard specimens, to simulate the actual loading conditions to which the full-size sections are subjected in service. It should be realized that even though the tests on full-size sections may be better, they are not always practical, and that standard practice, for most applications, probably still is to use the data from standard test specimens with appropriate and fairly large factors of safety.

#### CREEP STRENGTH

Creep<sup>14</sup> is a slow spontaneous elongation of a material with time, when dead loaded to a fixed value. Tests usually are conducted at a constant temperature, although this need not necessarily be done. If a specimen is subjected to a fixed dead load greater than its elastic limit at the testing temperature, it will elongate fairly rapidly, initially. This first stage of creep

<sup>13</sup> See, for example, *Physical Testing of Metals*, by H. D. Churchill: A.S.M., Cleveland, Ohio, 1936.

<sup>14</sup> For more complete discussion see J. J. Kanter, *Metals Handbook*, A.S.M., 1939, 504-511.

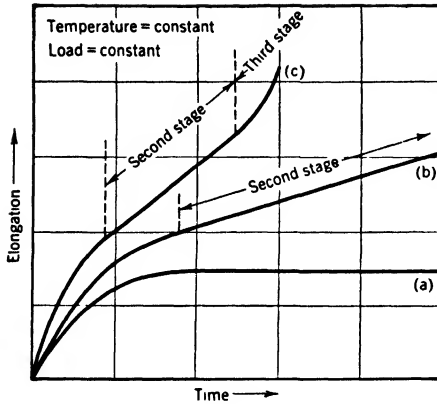


FIGURE 17. Idealized creep curves for metals held under a constant load at a constant temperature.

- a. Curve taken in range in which work-hardening occurs tends to become horizontal as the metal strengthens and supports the load.
- b. Curve taken above work-hardening range frequently tends to attain a steady state which may persist for a very long time.
- c. Curve taken above work-hardening range may tend to pass relatively quickly into a third stage in which rapid elongation occurs.

17, sometimes necking down, until fracture occurs.

Creep data, of course, are of the greatest importance in applications where a given dimensional change must not be exceeded within the life of the equipment. Although the fundamental causes of creep still are unknown, many of the factors influencing it have been determined, and will be discussed in more detail later. Unfortunately, no short-time test has yet been found which assists materially in predicting the results that would be secured under long-time creep loading. This means that the securing of reliable creep data is an extremely time-consuming job, and that, even at best, only the results of relatively simple loadings can be studied.

#### TIME FOR RUPTURE

For many applications, tests to determine the time at which rupture occurs under a given loading may be of even greater importance than the actual elongation of the specimen, or its rate of elongation by creep, because the time for rupture indicates tendencies under overloads not called for by

is a combination of both elastic and plastic deformation. If the test is made in a temperature range in which work-hardening will occur, this initial deformation will work-harden the specimen until it can support the applied load without further deformation. The elongation-time curve under these conditions will tend to become horizontal, as in (a) Fig. 17. If, however, the alloy is tested in a temperature range above that in which work-hardening occurs, then this initial rapid deformation will decrease to a steady rate of elongation known as the second stage of creep. This nearly constant rate, indicated by the straight line portion of curve (b) in Fig. 17, may persist for very long periods of time; but eventually it probably will pass into a third stage during which the specimen elongates rapidly, as shown in (c) Fig.

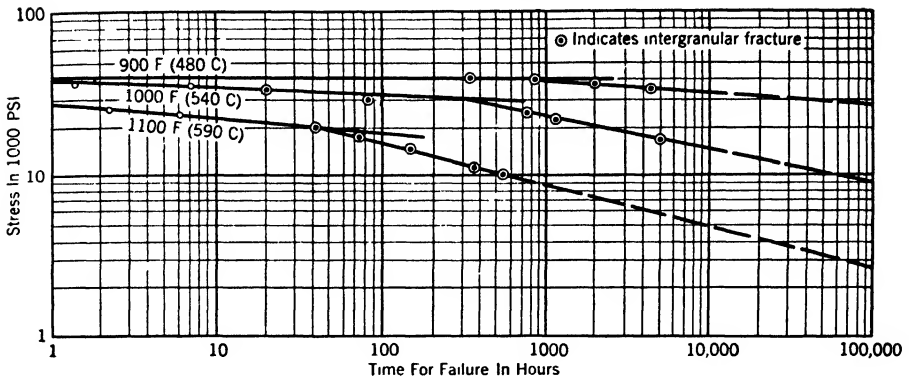


FIGURE 18. Stress vs. time for rupture curves for a carbon-molybdenum steel. The initial straight-line relationship is followed as long as the steel is stable under the temperature and atmosphere used. More rapid deterioration (instability) is marked by a steeper slope of the lines (dashed). (From R. H. Thielemann, *Proc. A.S.T.M.*, **40**, 1940, 791.)

the design. Indications are, although tests still are being carried out, that the time for rupture at any temperature is some function of the applied load, as indicated in the log-log plot of Fig. 18. The oxidation of the alloy appears to affect the time markedly and, for best results, this should be guarded against and minimized. However, the test is fundamentally different from creep and does not correlate any better with it than do short-time tensile tests.

### RELAXATION

*Relaxation*<sup>15</sup> is a phenomenon somewhat similar to creep, the main difference being that the load continually decreases or relaxes, instead of remaining constant. It is particularly significant for structural elements that are deformed a predetermined amount and then are expected to carry a load at this deformation. Thus, a tightened bolt may relax at certain temperatures by elongating to such an extent as to remove all its tension. Under such conditions the bolt will no longer fulfill its function and becomes useless simply because it was employed in the wrong temperature range. Relaxation design is still not on a sound basis, although a considerable amount of work is being done in this field.

### RESISTANCE TO HEAT

For high-temperature applications it is essential not only that a metal or alloy retain its mechanical properties, but also that it resist oxidation and

<sup>15</sup> See, for example, E. L. Robinson, *Trans. A.S.M.E.*, **61**, 1939, 543-550.

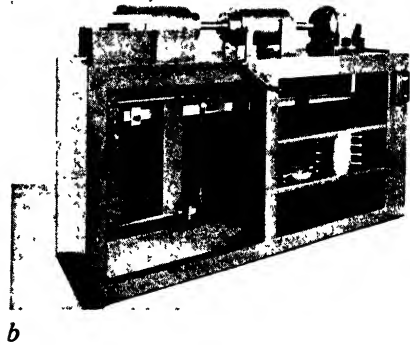
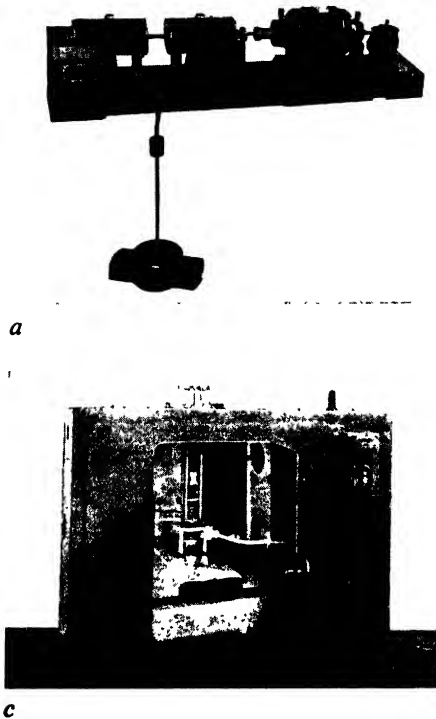


FIGURE 19. Some typical fatigue-testing machines:

*a.* R. R. Moore rotating beam machine.

*b.* Large-size R. R. Moore fatigue machine.

*c.* Baldwin Southwark universal fatigue machine for tension-compression, torsion, and flexure. (Courtesy Baldwin Southwark Division, The Baldwin Locomotive Works.)

other forms of corrosion. Materials that do both of these things satisfactorily are said to be *heat resisting*. However, in using this term, it always must be remembered that it is a general one, and might have a different specific meaning when applied to one class of alloys than it would have when applied to another.

Metals which have high melting points are generally those which have the greatest strength at elevated temperatures, and which impart the greatest strength when used as alloying elements. Hence, alloys of the engineering metals *iron* and *nickel* and of the metal *cobalt* are the important heat-resisting materials, and alloying elements like *molybdenum*, *nickel*, *tungsten*, *vanadium*, and *chromium* are apt to give interesting results. Oxidation resistance generally is increased by the presence, as alloying elements, of chemically active metals such as *aluminum*, *beryllium*, *chromium*, and *silicon* which tend to form tightly adherent refractory oxide coatings.

#### FATIGUE STRENGTH

Specimens subjected to a large number of cycles of stress reversals sometimes fracture at stresses within the elastic range which would otherwise

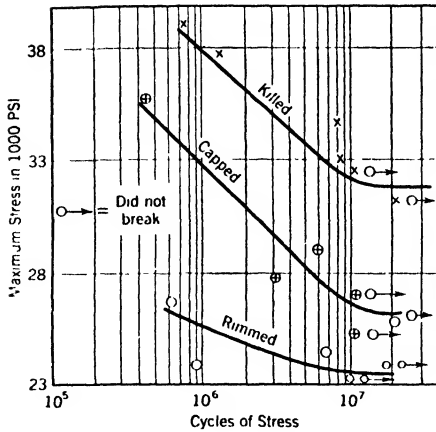


FIGURE 20. (Left) Stress-cycle diagram for killed, capped, and rimmed steels. (Courtesy *Metals and Alloys*.)

FIGURE 21. (Right) A typical fatigue fracture of a steel part. (Photograph courtesy Bethlehem Steel Company.)

produce no permanent deformation. It is probable indeed that most of the failures in rotating and reciprocating parts are of this type, known as *fatigue*.<sup>16</sup> Such stress reversals will occur in the outer fibers of rotating members, especially with imperfect alignment; in reciprocating members; and in parts, such as diaphragms, which are subject to pressures on both sides alternately.

Three types of commonly used fatigue-testing machines are illustrated in Fig. 19.

The number of cycles to cause failure will vary with the applied stress; the higher the stress the fewer the cycles to fracture. As the stress is lowered, the number of cycles to fracture will increase, as illustrated in the semilogarithmic plot of Fig. 20 for steels made by three different techniques, until eventually a stress is reached for which fracture will not occur within the limits of a standard test. The length of such a standard test depends on the material being tested and the type of loading. Preferably, it should be at least of the order of 500,000 cycles for very hard steel; 5,000,000 for soft steel; 10,000,000 for cast steel, and cast iron; and from 1,000,000 to about 50,000,000 for the nonferrous metals depending upon the metal. Indications are that if fracture does not occur within these limits, it will not occur at all.

<sup>16</sup> See *The Fatigue of Metals*, by H. F. Moore and J. B. Kammers: McGraw-Hill Book Company, Inc., New York, 1927. Report of Research Committee on Fatigue of Metals, *Proc. A.S.T.M.*, 30, 1, 1930, 259.

## FATIGUE FRACTURES

A fatigue failure, Fig. 21, has a crystalline appearance different from that of a static shear failure. The statement frequently is heard that the metal has failed because it has *crystallized* under the action of the repeated stress. This statement is, of course, *erroneous* since all metals are crystalline in nature and no change in their inherent crystallinity occurs because of the action of the repeated stresses. Fracture occurs, from static shear, after the section has been weakened by the propagation of minute cracks which form between and within the grains of the material by some process as yet not understood. By their manner of propagation these cracks tend to give the fatigue portion of the fracture a distinct crystalline appearance.

## FACTORS INFLUENCING FATIGUE

Any imperfection, such as a notch, inclusion, or other defect, may act as a stress raiser to initiate a fatigue crack.<sup>17</sup> Thus it is extremely important, in the design of machinery, to eliminate as far as possible all such sources of stress concentration, especially in shafts, connecting rods, and other parts subjected to large numbers of cycles of rotating or reciprocating motion or to dynamic loading of any sort. Certain of the possible danger points, such as inclusions and notches resulting from deep machining marks, gouges, dents, etc., cannot be eliminated by design alone although they usually can be restricted markedly by specification of suitable materials, especially with respect to internal cleanliness (inclusion ratings), or of surface finish. A surface finished with a high polish, for example, not only will be free from tool marks but also will be apt to be handled more carefully than one given only a finish cut. The airplane industry, in particular, realized this early in its life and has profited by it.

Fatigue cracks frequently start at radial oil holes or screw holes, in screw threads, keyways, or other regions where there is an abrupt change in section. Pits resulting from selective corrosion in operation are extremely dangerous and this is one reason for keeping all working parts clean and bright at all times. Frequently, the fatigue limit may be decreased 10–15% or more by pits resulting from improper care. When corrosion and fatigue act simultaneously, as in so-called corrosion fatigue, reductions as high as 65% have been noted. Under these conditions both the corrosion and the fatigue are accelerated with damaging results.

If only static stresses acted upon moving parts these defects would not be nearly as dangerous as they are. Static stresses would be much less complex

<sup>17</sup> See, for example, D. J. McAdam, Jr., and R. W. Clyne, *Journ. Res., Nat. Bur. Stand.*, **13**, 1934, 527; also Ref. 4 at the end of this chapter.

than those actually occurring in moving parts and hence could be better considered in the design. Their actual magnitudes would probably be lower and there would be a greater tendency toward, and greater opportunity for, distributing the stress more uniformly across the entire cross section of the member by gradual plastic deformation and work-hardening as discussed previously. In addition the slow plastic deformation would tend to eliminate the stress concentration by redistributing it and thus act beneficially. However, in moving parts, or in those subjected to dynamic stresses, there usually will be some part of the cycle in which the defective region alone must bear a large proportion of the load. Under these conditions the region is apt to become embrittled, possibly from extremely rapid deformation of minute portions, and to form a crack which then will propagate slowly until failure occurs. Obviously, once the crack occurs the remaining solid metal must bear a proportionately larger amount of the stress so the rate of propagation would tend to increase rather than decrease, as it does under static loading when work-hardening can occur. The presence of defects thus tends to lower the effective fatigue limit of the metal.

In general, a soft metal is apt to be less sensitive than a hard metal to the effect of notches, regardless of whether such hardness or softness is inherent or results from alloying, mechanical working, or heat-treatment. Since the decreased sensitivity is apt to result from the greater workability of the soft metal, its actual work-hardening capacity in comparison with that of the hard metal must be considered. Thus, almost any soft steel would be less sensitive to notches than a hard, and relatively brittle, hardened steel. This might not be true if the heat-treated steel had been so treated as to have considerable ductility. The desirable characteristics are apparently a fairly low yield strength and a good workability, so that considerable plastic deformation can take place, to distribute the stress concentration over a fairly large area, before any one region becomes embrittled and liable to crack.

Internal flaws, such as inclusions and holes, are very undesirable, not only because of the stress concentrations that naturally would result from any break in the solid metal, but also because the inclusion is apt to be much more unyielding than the metal, thus tending to concentrate the stress even more than if the hole were the only defect. Many companies specify an inclusion rating for the express purpose of controlling this variable.

#### DAMPING CAPACITY

The ability of a material to absorb or dampen vibrations, i.e., to dissipate internal energy as heat, during a completely reversed cycle of stress, as in-



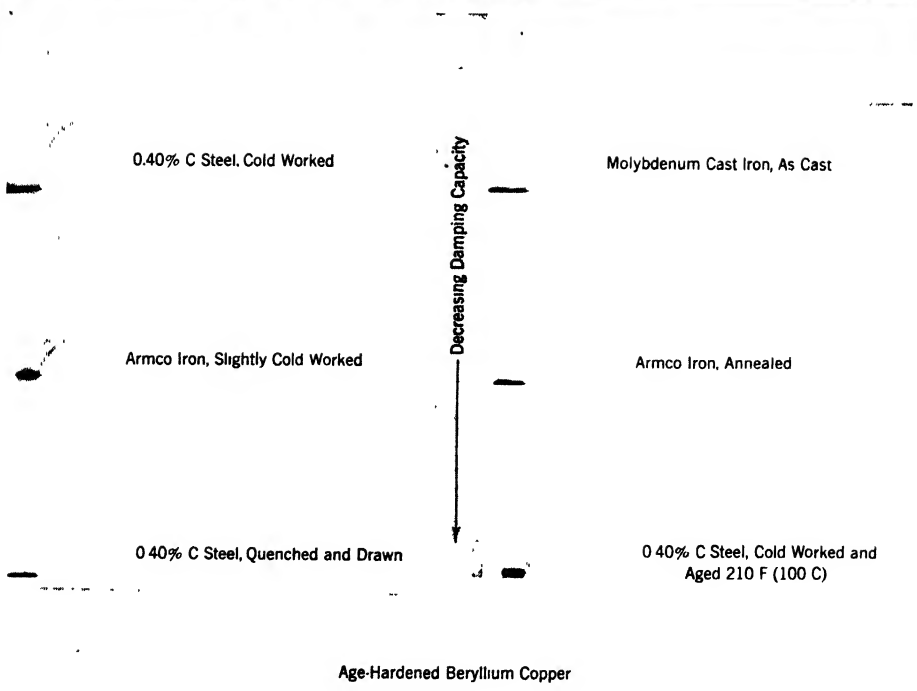
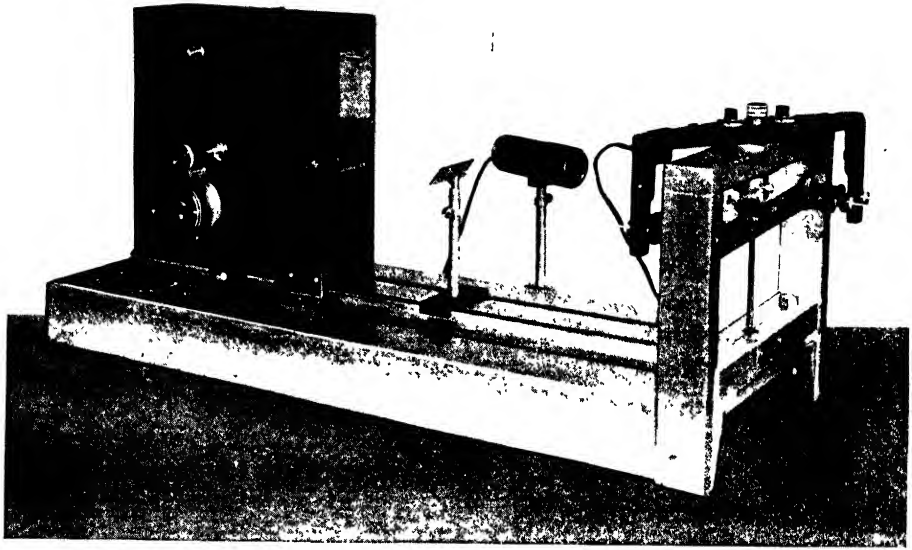


FIGURE 22. The Norton damping tester and some typical curves showing the rate at which vibrations are damped out by various materials. (Courtesy John T. Norton.)

licated diagrammatically in the Norton damping capacity<sup>18</sup> curves in Fig. 22, also appears to influence the fatigue resistance, although the exact significance of the relationship still seems to be somewhat controversial. Fatigue failure supposedly results from the fact that, at a constantly repeated stress above the endurance limit, damping increases at an increasing rate until fracture occurs, i.e., the material absorbs more and more vibrations internally until the stresses finally build themselves up to a sufficient magnitude to produce a minute crack. At a cyclic stress below the endurance limit, on the other hand, damping either attains a constant value, i.e., sufficient work-hardening occurs to distribute the stress concentration and then stops, or else decreases, because the stress is below the elastic limit, so no work-hardening occurs and the stresses are absorbed elastically.

It often is found that materials having a high damping capacity, such as gray cast iron, are resistant to notch effects, but not to overstress; and hence tend to have a low fatigue-endurance limit, which is relatively unaffected by surface conditions. On the other hand, materials having a low damping capacity, such as most heat-treated steels, are resistant to overstress, but not to notches; they therefore tend to have a high fatigue-endurance limit, although they are apt to be very sensitive to surface imperfections. This means that in using materials of a low damping capacity for applications where they are subjected to alternating stress cycles, great care must be taken to ensure good surface finish. This need not be done if the damping capacity is high.

In engineering design some consideration of damping capacity is bound to be necessary in the design of parts subjected to vibrational loads such as a bed of a high-speed machine, or a crankshaft of an engine. A material having a high tensile strength might be indicated by the design alone, but if its damping capacity were low the vibrations would build up to a high magnitude and failure actually might occur much more rapidly than it would have if a material of much lower tensile strength, but of higher damping capacity, had been selected.✻

### *Physical Properties*

#### ELECTRICAL CONDUCTIVITY

The ability of the metallic materials to conduct electricity is a characteristic which also is related, in some manner not as yet clearly understood, to their unique type of structure. Usually, it is more convenient to refer to the *resistance* of a material (in *ohms*) rather than to its *conductance* (in

<sup>18</sup> Damping capacity is discussed well by G. S. van Heyde Kampf, *Proc. A.S.T.M.*, **31**, II, 1931, 157-171; and by R. A. Flinn, Jr., and John T. Norton, *Trans. A.I.M.E.*, **128**, 1938, 143.

ohms). The resistance may be expressed as  $R = \rho \frac{L}{A}$  where  $R$  is the resistance in ohms,  $\rho$  the resistivity or specific resistance in ohms per centimeter cube<sup>19</sup> (dimensionally, in ohm-cm),  $L$  is the length of the conductor being measured, and  $A$  its cross-sectional area.

The best metallic conductor is silver, but copper, the best of the engineering metals, is only slightly inferior to it. Although the much higher cost of silver is a deterrent to its use, the time yet may come when government-owned silver stocks are stored normally as useful bus bars in electrical power stations rather than as useless ingots in a vault. This substitution was made, to some extent, as an emergency measure during World War II.

The International Annealed Copper Standard is considered to be 1.7421 microhm-cm or 0.67879 microhm-in. at 68 F (20 C). The relative conductivities (copper = 100%) and the absolute resistivities of the engineering metals are listed in Table V.

TABLE V ELECTRICAL CONDUCTIVITIES OF THE ENGINEERING METALS

	RELATIVE ELECTRICAL CONDUCTIVITY		ELECTRICAL RESISTIVITY
	<i>Per unit cross-sectional area</i>	<i>Per unit weight</i>	<i>Microhm-cm</i>
Silver	108	92	1.468
Copper	100	100	1.6
Aluminum	61	201	2.6
Magnesium	37	180	4.4
Zinc	28	35	5.8
Nickel	23	23	6.3
Iron	18	20	8.8
Tin	12	14	13.0
Lead	8	6	20.4

It will be seen readily that the lower specific gravities of both aluminum and magnesium permit them to have appreciably greater cross-sectional areas per unit length and weight, making them better relative conductors than the heavier metals on an equal weight basis. Likewise, silver is inferior to copper on this basis because of its specific gravity, which is greater than that of copper.

<sup>19</sup> A centimeter cube is a cube 1 cm on each side, and should not be confused with a cubic centimeter which is merely a volume with no directional specification.

## SUPERCONDUCTIVITY

Some metals become superconducting below a temperature which is characteristic for the substance and which is generally less than about 8 K (−445 F). In a closed conductor of these metals, an electric current once set up will continue to flow for many hours after the voltage is removed, because of the extremely low resistance. This phenomenon is not as yet understood and has, at present, no practical significance. Future development of its use cannot be predicted.

Of the important metals, *lead* (7.2 K), *mercury* (4.2 K), *tin* (3.7 K), and *molybdenum* (1 K) become superconducting at the temperature shown and zinc and aluminum do not display this characteristic so far as is now known.

## THERMAL CONDUCTIVITY

Although the thermal conductivity of metals is high, it is by no means so great that heat will flow<sup>20</sup> through them instantaneously. In general, this property, usually expressed in calories per square centimeter per centimeter per second per degree Centigrade (or in British thermal units per square inch per inch per second per degree Fahrenheit), parallels the electrical conductivity although there are some deviations. A relation between the two is expressed by the empirical *law of Lorentz*, sometimes referred to erroneously as the *law of Wiedemann-Franz*, which states that the ratio between the thermal conductivity and the electrical conductivity is proportional to the absolute temperature:

$$\frac{\text{Thermal conductivity} \times 10^8}{\text{Electrical conductivity}} = C \times T$$

where  $C$  is a constant having a value between 2.23 and 2.51; and  $T$  is the absolute temperature in degrees Kelvin.

The relative (copper = 100%) and absolute thermal conductivities (in calories per square centimeter per centimeter per second per degree Centigrade) at room temperature, of silver and of the engineering metals are listed in Table VI.

## FACTORS AFFECTING THERMAL AND ELECTRICAL CONDUCTIVITY

Electricity and heat seem to be conducted through metals in some manner by the free or valence electrons which exist in unique fashion in the metallic type of structure. In addition, the lattice itself apparently aids in

<sup>20</sup> Heat flow is discussed well in *Heat Flow in Metals*, by J. B. Austin: A.S.M., Cleveland, Ohio, 1942.

TABLE VI THERMAL CONDUCTIVITIES OF THE ENGINEERING METALS

	RELATIVE THERMAL CONDUCTIVITY	THERMAL CONDUCTIVITY
Silver	106	0.97
Copper	100	0.92
Aluminum	52	0.48
Magnesium	40	0.37
Zinc	30	0.27
Iron	18	0.16
Tin	17	0.16
Nickel	15	0.14
Lead	9	0.08

(1 cal/sq cm/cm/sec/deg C = 0.0054 Btu/sq in./in./sec/deg F)

conducting heat, which is one reason why the two conductivities are not the same. The greater the perfection of the atomic arrangement in a crystal the lower will be its resistance to the flow of electricity or heat. Any factors which tend to disturb this perfection, such as an increase in impurity content, temperature, or strain, tend to increase the resistance of the metal to the flow of either electricity or heat. Consequently, conductivity is greatest for the soft pure metals, and is decreased by alloying. The magnitude of this latter change, and the manner in which it occurs, are determined by the type of alloy formed. Even small percentages of impurities may exert an appreciable effect if they alloy in the proper manner, although, because of reactions between them, the combined effects of several impurities might appear to be anomalous in comparison with their individual effects.

Unlike oxides, the conductivity of metals is decreased somewhat by an increase in temperature. If the resistance at any temperature,  $R_o$ , is known, the resistance,  $R_t$ , at any other temperature,  $T$ , is given approximately by the equation

$$R_t = R_o (1 + \alpha_o [T - T_o])$$

where  $R_o$  is the resistance at the temperature,  $T_o$ ; and  $\alpha_o$  is the temperature coefficient of resistance, frequently a function of temperature itself so the plot would not necessarily be linear.

Work-hardening also generally decreases the conductivity to some extent. Although this change is usually less than about 5% of the initial value, it may run as high as 20% with some alloys.<sup>21</sup>

<sup>21</sup> See, for example, D. K. Crampton, H. L. Burghoff, and J. T. Stacy, *Trans. A.I.M.E.*, **143**, 1941, 228-241.

THERMAL EXPANSION

The *linear coefficient of thermal expansion* of solid metals,  $\alpha_l$ , is usually greater than that of most other solid materials. By proper alloying, however, it is possible so to modify this property that metallic materials can be made with expansions identical, in certain temperature ranges, with many nonmetallic materials. This is a valuable property for some applications, such as glass-metal seals for example. Alloys even can be made which will have practically no measurable expansion in certain fairly broad ranges of temperature, and hence are extremely useful for dimensional standards of all sorts.

The average linear coefficients of thermal expansion of the common metals in the range 0–200 F are all fairly high, and may be expressed by the relationship:

$$l_t = l_o (1 + \alpha_l [T - T_o])$$

where  $l_t$  is the length at the temperature  $T$ , and  $l_o$  that at  $T_o$ .

Some of the values commonly used for the engineering metals are shown in Table VII. It must be remembered, however, that these values are secured in the vicinity of room temperature and may be considerably different in other temperature ranges even with pure metals.

TABLE VII APPROXIMATE LINEAR THERMAL EXPANSION COEFFICIENTS FOR THE ENGINEERING METALS

	$\alpha_l$ in./in./deg F $\times 10^6$
<i>Tin</i>	19.2
<i>Lead</i>	16.4
<i>Zinc</i>	15.2
<i>Magnesium</i>	14.3
<i>Aluminum</i>	13.3
<i>Copper</i>	9.1
<i>Nickel</i>	7.6
<i>Iron</i>	6.6

The *volume coefficient of thermal expansion*,  $\alpha_v$ , generally is taken to be three times the linear coefficient,  $\alpha_l$ :

$$V_t = V_o (1 + \alpha_v [T - T_o])$$

Here,  $V_t$  is the volume at the temperature  $T$ , and  $V_o$  that at  $T_o$ .

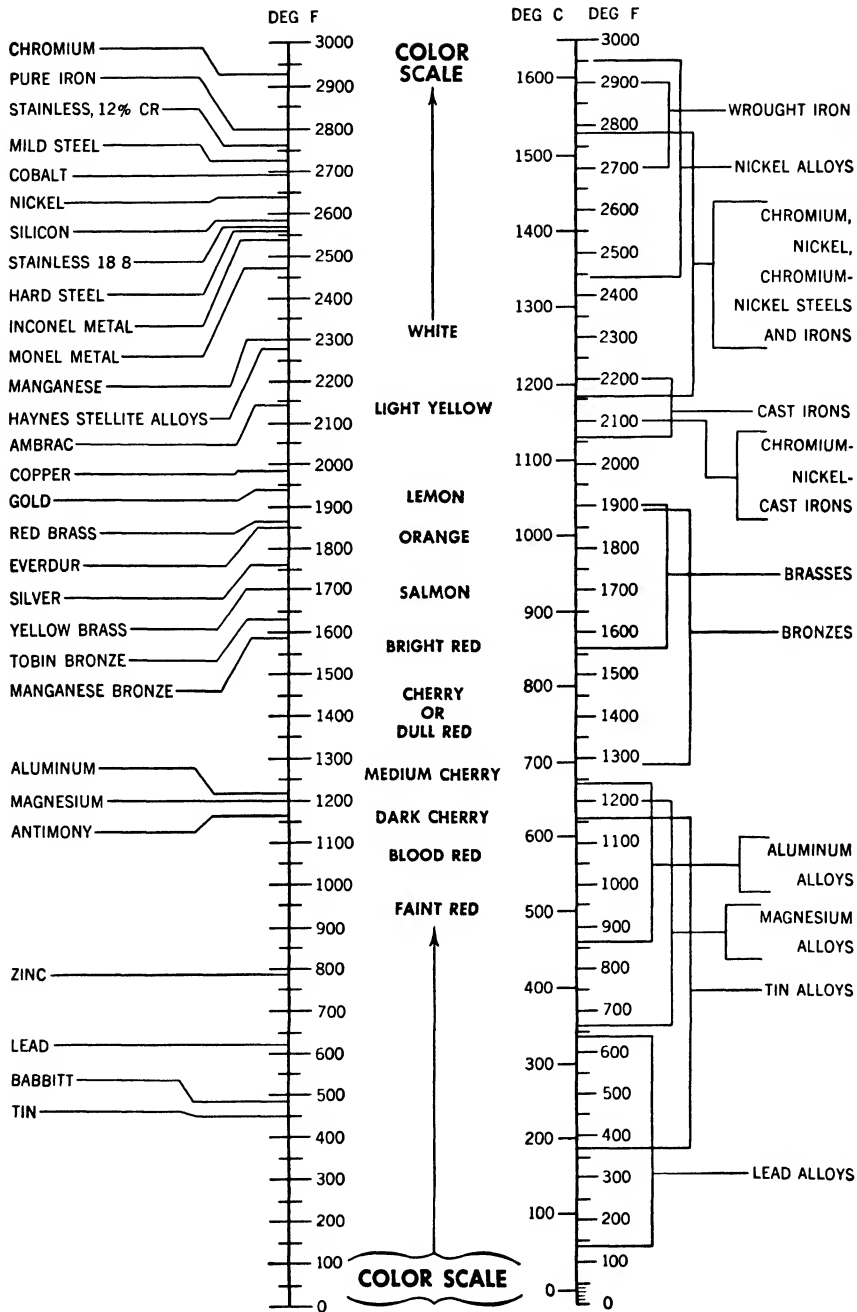


FIGURE 23. Melting points of metals and alloys of practical importance. (Courtesy The Linde Air Products Company.)

MELTING TEMPERATURES

In Fig. 23 are shown the temperatures at which the important metals and alloys become liquid. For applications in which melting point is important, such a chart is extremely helpful for selecting the general types of metals that can be considered.

Especially noteworthy are:

1. The wide range of temperatures at which the various metals and alloys melt, extending from room temperature to almost 3000 F (1650 C).
2. The fact that alloys of any given metal generally will melt at a lower temperature than the pure metal.

SPECIFIC GRAVITY

The specific gravities of the solid metals at room temperature, as indicated by the values for some of them listed in Table VIII, cover a wide range, extending from values greater than 22 to those less than 1. Even the engineering metals cover a fairly wide range, and this will, in some cases, be an important factor in selecting alloys for given applications since volumes will vary inversely as the specific gravities for a constant weight. The significance of this on the electrical conductivity already has been shown, and its influence with respect to mechanical properties will be discussed later.

TABLE VIII SPECIFIC GRAVITIES OF THE ENGINEERING METALS

	SP GR
Lithium	0.53
<i>Magnesium</i>	1.74
<i>Aluminum</i>	2.70
<i>Zinc</i>	7.14
<i>Tin</i>	7.30
<i>Iron</i>	7.87
<i>Nickel</i>	8.90
<i>Copper</i>	8.94
Silver	10.50
<i>Lead</i>	11.34
Gold	19.32
Platinum	21.45
Iridium	22.42



The specific gravities of alloys generally are found to be intermediate between those of the alloying metals, although the relationship need not be, and seldom is, linear.

#### DENSENESS

Not to be confused with *aensity* (weight per unit volume) is the term denseness, often used in metallurgy. Density is a specific property of the metal, determined by the atomic weight, atomic volume, and atomic arrangement; and is nearly independent of the shape, size, or other similar variations in the crystals of a crystal aggregate. Denseness, on the other hand, is the opposite of *porousness* and refers roughly to the density of the metallic aggregate as a whole, including inclusions, interior cavities, etc. The denseness of any material can be raised by the process of manufacture, but its true density is fixed.

Frequently the term density is used loosely for *apparent density* and in this use would include both the real density and the denseness.

#### DETERMINATION OF POROSITY

Various methods are used commercially to study the actual porosity or soundness of a given casting, weld, or other section. These may be destructive tests, such as fracturing or metallographic examination, or they may be nondestructive. The latter, although more expensive, are generally of much greater value because they permit study of the actual piece to be used rather than one made in a similar manner which might be far from identical.

#### NONDESTRUCTIVE TESTS

Four types of nondestructive tests are common today, each having certain fields of usefulness in which it is somewhat preferable to the others.

**RADIOGRAPHY** Electromagnetic waves of extremely short wave lengths ( $0.1-0.5 \times 10^{-8}$  cm or less) will pass through metal just as visible light will pass through glass and other transparent media. Radiation of these wave lengths can be produced readily as X rays by the bombardment of elements, preferably those of high melting point and high atomic weight like tungsten, with high-velocity electrons in a vacuum tube; or as gamma ray emanations from radium or radioactive salts. In addition, they can be detected readily because of their effect on a photographic plate or a fluorescent screen.

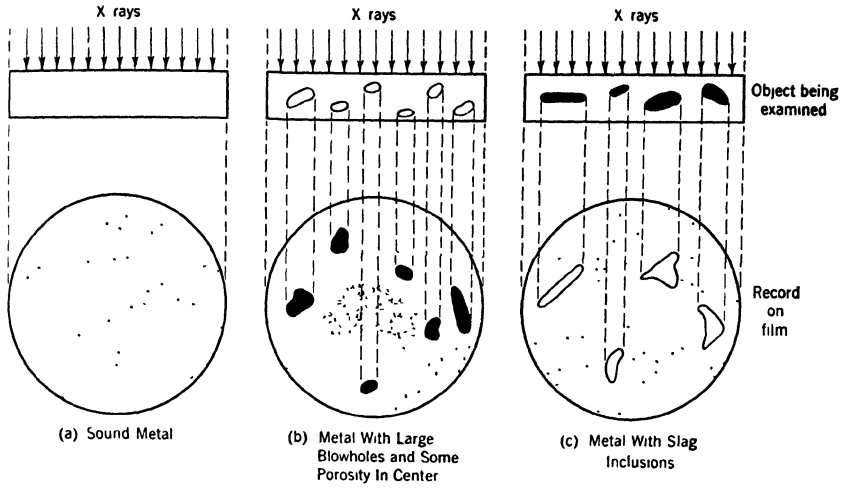


FIGURE 24. Schematic representation of X-ray negatives produced by radiographing metal containing various types of defects.



FIGURE 25. Radiographs of four welds illustrating (left to right): a. Lack of penetration of weld metal. b. Porosity. c. Slag inclusions. d. A good sound weld. (Courtesy General Electric X-Ray Corp.)

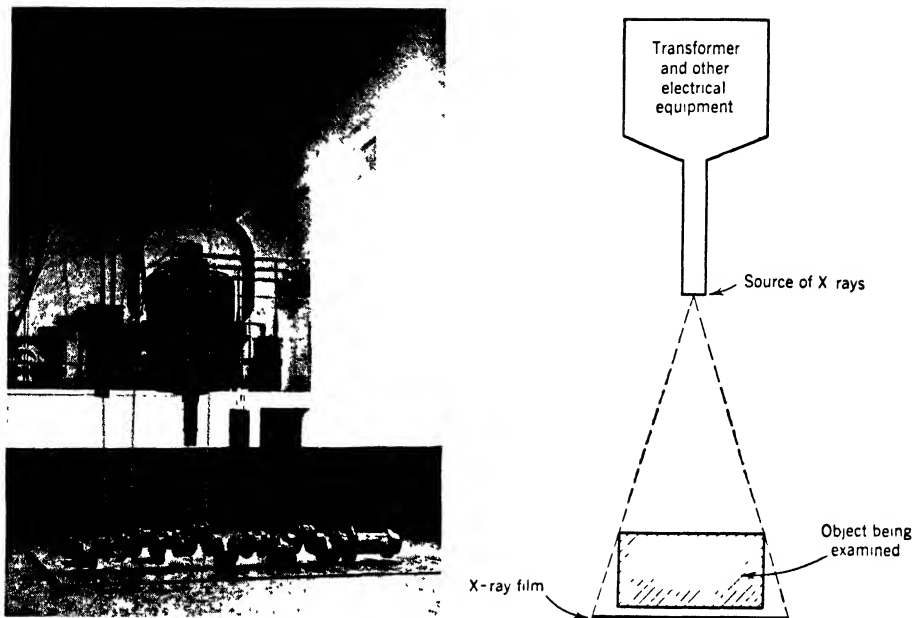
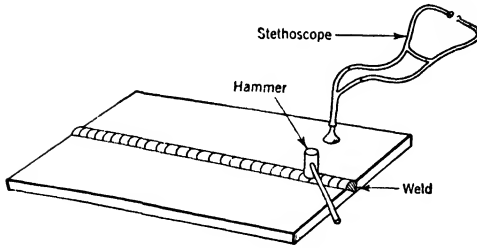


FIGURE 26. Latest type of shockproof, totally enclosed, portable, 1,000,000-v X-ray unit for radiographic examination of metals. (Courtesy General Electric X-Ray Corp.)

The basis of the radiographic method is illustrated in Fig. 24. Radiation passing through a specimen will be absorbed to some extent. If it passes through an internal hole, the absorption is less, more rays reach the film, and a dark spot results. If it passes through an inclusion, the absorption is frequently greater, fewer rays reach the film, and a light spot results. By proper evaluation of the film intensities, the soundness of the piece and the location and probable nature of the defects thus can be determined. Typical films are shown in Fig. 25.

These methods now can be used satisfactorily for all thicknesses up to about 8 in. or more, although the cost of the necessary equipment is somewhat high. The thickness that can be penetrated by X rays depends upon the metal being examined, the heavy metals, of high atomic weight, being more difficult to penetrate than the lighter metals; and upon the voltage across the X-ray tube. Commercial installations as powerful as 1,000,000 v have been constructed (Fig. 26) and are in use penetrating up to 8 in. of steel; and units as large as 10,000,000 v are under development.

**SOUND** Some measure of soundness can be gotten by tapping the suspected piece with a light hammer while examining it with a stethoscope or similar instrument (Fig. 27). For this method to be used at all, however, considerable experience is required and, even then, the reliability is not too good. Supersonic methods using high-frequency oscillators which



27



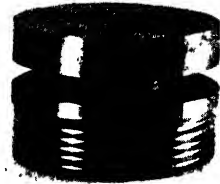
28a



29a



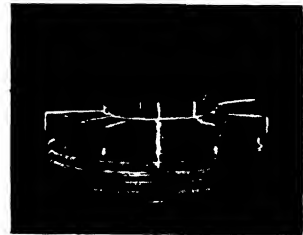
29b



28b



29c



29d

FIGURE 27. Stethoscope testing of welds. (From *Metals Handbook*, courtesy American Society for Metals.)

FIGURE 28. Indications of: *a.* grinding cracks in gear, *b.* cracks in gun breech part, as outlined by magnetic powder testing (*Magnaflux*). (Courtesy Magnaflux Corporation of New York. Part *b* reproduced, by permission, from *Principles of Magnaflux Inspection* by F. B. Doane.)

FIGURE 29a. Grinding cracks in Diesel wrist pin as indicated by *Magnaglo* process. *b.* Service cracks on Stellite-faced aircraft engine valve as indicated by *Zyglo* process. *c.* Heat-treat cracks in cast-aluminum aircraft fitting as indicated by *Zyglo* process. *d.* Cracks in gun breech part as indicated by *Magnaglo* process. (Courtesy Magnaflux Corporation of New York.)

become unbalanced in the presence of defects also have been used<sup>22</sup> with success in certain cases.

**MAGNETIC METHODS** Electromagnetic methods, such as *Magnaflux*,<sup>23</sup> depend upon the fact that the magnetic reluctance of a ferromagnetic material is increased by any fault occurring in it. If a heavy direct current is passed around a piece of a *magnetic* metal, in the proper direction, the magnetic field produced by it will be concentrated at the surface of any internal defects. By covering the surface with fine ferromagnetic particles the defect will be outlined and so revealed (Fig. 28). This method is best applied to sections less than  $\frac{1}{2}$  in. thick. It is reliable and fairly inexpensive to use, and is employed widely for small pieces whose shape is not suitable for X-ray examination. The magnetic particles may be applied either dry or in suspension in a liquid, depending upon the particular shape being examined.

Other magnetic methods have been used, but usually they have proved to be so complex and so sensitive to external conditions as to be of little practical importance to industry.

**USE OF FLUORESCENT PENETRANTS** Cracks and porosity in metals which are open to the surface may be located by use of a suitable penetrating fluid carrying a highly fluorescent dye. Extremely minute quantities of this fluid will be drawn into the cracks by capillary attraction, and later made visible by exposure to near-ultraviolet radiation, i. e., "black" light. The excess penetrant always must be removed, and frequently the liquid in the cracks must be brought to the surface by applying a finely divided powder if the cracks are to be made visible. This method is used commercially under several names, two of the better known of which are *Magnaglo* for magnetic parts, and *Zyglo*, for nonmagnetic parts, the techniques in each case differing slightly. The general appearance of cracks in several typical parts is shown in Fig. 29.

#### SPECIFIC HEAT

The specific heat of a metal is the amount of heat required to raise the temperature of a unit mass 1 degree. Although it is seldom used directly, it has a distinct effect upon such phenomena as the rates of cooling and heating, etc. Specific heats of the metals at atmospheric temperatures, range from a minimum of about 0.03 to a maximum of about 0.3. Either of the identical units British thermal units per pound per degree Fahrenheit, or calories per gram per degree Centigrade, may be used.

<sup>22</sup> See, for example, A. Behr, *Metallurgia*, 23, 1940, 7-11.

<sup>23</sup> Consult the S.A.E. Handbook for a discussion of S.A.E. recommended practice; also "Symposium on Magnetic Particle Testing": *A.S.T.M.*, Philadelphia, Pa., 1945.

## COLOR

The color of metals arises from their ability to absorb or reflect various wave lengths. Most metallic materials are blue-white to gray in color, indicating an absorption band outside the visible range. However, *copper* is red and *gold* is yellow; and, by proper alloying, many other gradations of color throughout the visible range can be produced because of the fact that the longer wave lengths are reflected whereas the shorter ones are absorbed.

## MAGNETIC PROPERTIES

Most generally referred to as *magnetic* are the so-called ferromagnetic substances which include only *iron*, *cobalt*, and *nickel*, and certain alloys containing either these metals or manganese and chromium. Magnetism again is determined by the atomic structure, and apparently arises largely from the rotations of certain of the electrons in the atom, but an entirely satisfactory explanation of it still has to be given.

## PERMEABILITY

The ratio of the magnetic induction, or the flux density  $\beta$  (in *gauss* or lines of force per sq cm), to the applied magnetizing force, or the magnetic field intensity  $H$  (in *oersteds* or  $0.4 \pi$  times the ampere turns per cm), is called the permeability,  $\mu$ . In practical measurements, however, it is more customary to refer to the *relative permeability*,  $\mu_r$ , which is the ratio of the permeability of the metal,  $\mu$ , to the permeability of a vacuum (or of air),  $\mu_0$ .

The permeability is the *magnetic conductivity* of a material and, except for the ferromagnetic alloys, for which the relative permeability may be as high as 100,000, it is usually about 1. Metals whose permeability is slightly less than 1 are said to be *diamagnetic*, and those for which it is slightly greater than 1, *paramagnetic*.

## HYSTERESIS

If the magnetizing force applied to a previously unmagnetized ferromagnetic material is increased to some value  $H_{\max}$ , and is then reduced gradually to zero, the flux density,  $\beta$ , corresponding to a given value of  $H$ , is greater while  $H$  is being diminished than it was while  $H$  was being increased. Even when  $H$  is reduced to zero,  $\beta$  still has an appreciable magnitude known as *residual* or *remanent* magnetism,  $\beta_r$ .

If a magnetizing force in the reverse direction then is applied, and

gradually increased,  $\beta$  continues to diminish until it becomes zero at a negative magnetizing force, the numerical value of which is the *coercive force* of the material,  $H_c$ .

If the negative magnetizing force is then increased to a maximum value equal to the previous positive maximum, i.e., to  $-H_{\max}$ , reduced again to zero, reversed, and increased to the original positive maximum value, a cyclic process is carried out which, when  $\beta$  is plotted against  $H$  (Fig. 30), is represented by a symmetrical loop called the *hysteresis loop*. The important point about such a loop is that it shows that the magnetic behavior of the material is dependent on its previous magnetic history. The area of the loop also represents the energy which need be expended to carry the material through the corresponding cycle of magnetization.

If alternating-current magnetization is used, a further energy loss occurs in magnetic materials because of the induction of *eddy currents*. The energy so expended is transformed into heat, and its magnitude is the principal factor in determining the temperature rise in electrical machinery and transformers which are subjected to alternating magnetization.

#### REMANENCE AND COERCIVITY

Both the *remanent magnetism*,  $\beta_r$ , and the *coercive force*,  $H_c$ , increase in magnitude with the maximum magnetizing force,  $H_{\max}$ , for which the hysteresis loop is described, but they approach limiting values very rapidly. These limiting values, known as the remanence and coercivity, are specific properties of the material.

#### PERMANENT MAGNETS

Materials suitable for permanent magnets must be capable, after the application and removal of a large magnetizing force, of maintaining a considerable flux across an air gap (Fig. 31). This residual magnetism and the ability of the material to retain it depends on the composition; the treatment, both thermal and mechanical; and the geometrical shape of the particular piece.

#### ELECTROMAGNETS

The introduction of a soft iron core into a magnetizing coil greatly increases the field strength obtainable from it. If no current flows through the coil, the core will have no magnetism since, being made of soft iron, it has no residual magnetism. When current flows, however, a certain magnetomotive force will be developed. Usually the core is of such

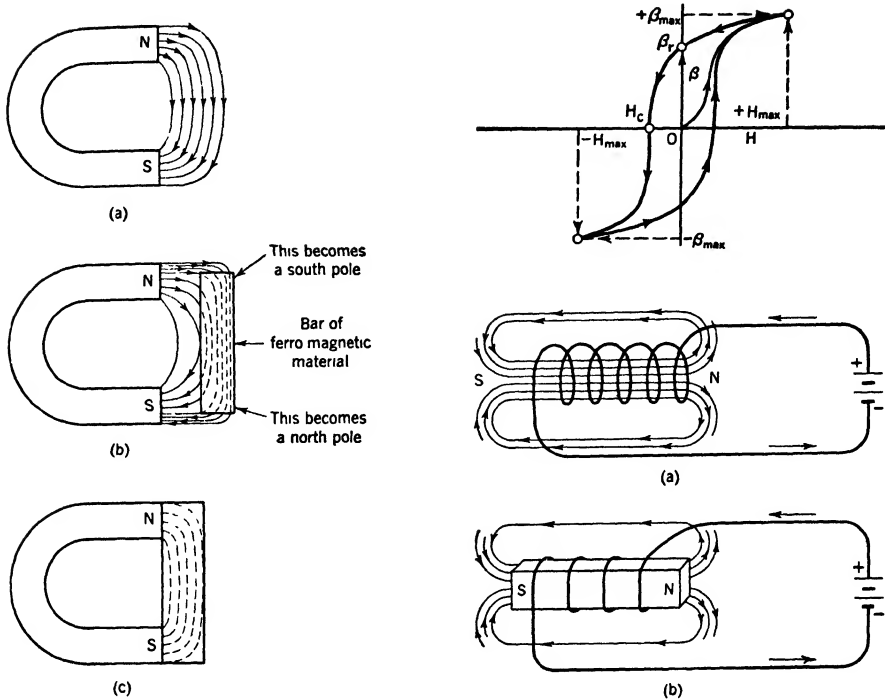


FIGURE 30. (Upper right) Typical magnetization curve and hysteresis loop. Coordinates represent magnetizing force  $H$  in oersteds (1 oersted =  $0.4\pi$  amp turns per cm) and magnetic flux density  $\beta$  in gauss (1 gauss = 1 line of force per sq cm).

FIGURE 31. (Left) Diagrammatic representation of a permanent magnet. *a.* Lines of magnetic force from a permanent magnet. *b.* Bar of ferromagnetic material is magnetized to opposite polarity by magnetic field and attracted. *c.* Lines of magnetic force now are concentrated and run through the ferromagnetic material.

FIGURE 32. (Lower right) Diagrammatic representation of an electromagnet. *a.* Lines of force in a current-bearing helix. *b.* When a soft steel core is placed in the helix the lines of force pass into it and it becomes a magnet by induction.

material that the flux will vary with the magnitude of the current in the coil. This is illustrated in Fig. 32. Every magnetic material, however, has a saturation point beyond which the magnetic flux density cannot be increased, so this will limit the current required in the coil.

### Some Economic Considerations

#### ENGINEERING DESIGN

The engineer has a specific task in that he must adapt existing materials and sources of energy efficiently in order to satisfy the requirements of industry. To do this, he must be familiar with the commercial metals and



alloys, with the properties which they can possess, and with the methods available for developing or modifying any of these properties. His problems are simplified somewhat by the fact that engineering designs are restricted usually in a more or less definite manner by limitations of space, weight, and cost, which automatically will eliminate many materials from consideration. In consequence, it is seldom that alloys of more than two or three of the eight engineering metals even can be considered for any given application, except under extraordinary conditions.

To the engineer unit stresses are important, and structural members must be designed to withstand these stresses. Since the load-bearing capacities of each alloy are fixed more or less, the minimum dimensions of any member are determined by the loads it must carry, and by the factors of safety that must be used. The greater the confidence of the engineer in his design and in his materials, and the greater the necessity for this confidence, the lower these factors of safety can be, and the more efficient will be his work. After all these items have been considered, the final selection of a material from among the available possibilities is frequently more a matter of arbitrary convenience than anything else, because any one metal or alloy seldom is found to be outstandingly superior to its competitors in every respect.

#### METAL COSTS

Metals generally are sold by *weight* and used by *volume*. Hence, alloy costs are not determined by the cost per pound of the components but rather by a combination of the metal cost of the alloy in the amount desired, plus a cost for fabrication and finishing, plus a certain amount for profit and overhead. It should be obvious, therefore, that the consumer who specifies a standard analysis in common shapes and sizes probably will get much quicker deliveries, if not a better price, than one for whom everything must be especially made.

It is important for the engineer, consequently, to consider carefully which of the standard forms of common alloys most nearly will give him the essential properties he requires rather than to attempt to find new materials to use in order to furnish what he thinks he needs. To do this requires a reasonable familiarity with metallurgical materials and processes, but in most instances, the savings so permitted more than justify the trouble involved.

In general, and only as a rough guide, it will be found that the commercial iron alloys are the cheapest of the commercial metals. They will have a base cost per pound under normal conditions of about one-third

as much as lead or zinc, one-fifth as much as copper, and one-eighth, or less, as much as aluminum, magnesium, nickel, or tin. On a volume basis these relationships naturally will be different.

#### FABRICATION AND FINISHING COSTS

In practically every case, most of the value of a finished article results from the work that has been done upon it, rather than the initial cost of the metal involved. Hence it is foolish to endeavor to economize on the basis of metal cost alone, unless it can be shown definitely that by so doing no loss in productive capacity will result.

Machining operations, in particular, increase costs to a greater extent than, probably, any other factor, not only because they are usually harder on tools than other shaping and forming operations, but also because each material has definite limitations regarding the rate at which it can be machined to produce any given dimensional tolerance and surface condition. Because of its importance more attention should be paid to machinability than to any other factor. This can be taken into account in several ways. First, any part should be formed into a shape as close to the final shape as is possible by means other than those involving machining. Obviously, the less the volume of metal that must be removed the less the time that will be required and the lower the costs. Second, the design should be carefully studied to be sure that all machined surfaces, and especially those requiring close dimensional tolerances, will be readily available using only the simplest machines. Complex and special machines are expensive and their use often can be avoided. Third, materials should be selected which will give the optimum combination of machining speed and surface finish. This sometimes necessitates specifying not only a particular composition and heat-treatment, but also metal made by a particular process, because with steel, the most commonly used commercial material, more than with any other material, careful production control is needed for best results. If automatic machines are used this is especially important because, for this purpose, uniformity of material and reproducibility of results are required. Materials must be of such character that machines can run for days or weeks at a time with only a minimum of care and attention from the operator.

The economics of each individual case differ and must be considered separately. In some instances alloys with improved machinability are less expensive than the standard types because they can be produced from lower grades of materials or by simpler methods of fabrication. In other instances, the improved alloys are proprietary and hence must carry cer-

tain development costs, or must be made by special processes which increase their cost of manufacture. Frequently the engineer may be "oversold" into specifying a material whose machinability is much better than the machines available can utilize efficiently. In all such instances there is probably no substitute for an actual trial, and the best method is still to make test runs of the various materials, which seem to be similar in other respects, in order to determine which works best for that particular purpose.

#### TREATMENT

Most alloys require certain heat and mechanical treatments for the development of their optimum engineering properties. The internal stresses incident to these treatments must be considered carefully with relationship to the design chosen in order that possible damage will be minimized. Selection of a different material, perhaps even a more expensive one, and different methods of treatment often will develop identical or even superior properties with less danger of spoilage. Unless special equipment for the purpose happens to be available, it is usually advisable to investigate all feasible methods for producing a given set of properties before the ultimate decision as to the choice of alloy is reached.

#### PROBABLE LIFE IN SERVICE

Service life is a combination of the three factors: corrosion, wear, and obsolescence. It is seldom that a properly designed engineering structure fails for other reasons. With proper training and experience, the first two of these usually can be taken care of adequately by proper specification of materials and methods of protection. However, the factor of obsolescence, although it is sometimes difficult to evaluate, should also influence the selection of materials.

Although it is usually not advisable to design for much more than the probable life of the structure or machine, a proper perspective must be maintained. Underdesigning may be dangerous because of possible results of premature failure or breakdown. A more expensive material, which is almost sure to need no repair, may be vastly superior to a cheaper one that might fail in service within its probable useful life. Breakdown introduces labor charges, if nothing more serious, and these are always high. When the dead load is limited, as in aircraft, some of these points become even more important because then the factor of safety must be kept low, without sacrificing in any way the effective strength of the structure.

## SPECIFICATIONS

Based upon experience, certain companies or professional societies have drawn up specifications covering engineering materials of types commonly used. Such groups as the American Standards Association (A.S.A.), the American Society for Testing Materials (A.S.T.M.), the Society for Automotive Engineers (S.A.E.), the American Iron and Steel Institute (A.I.S.I.), and the various United States government agencies have done admirable work in preparing specifications, thereby assisting in the standardization of industrial materials with consequent increased uniformity and decreased costs. These standards will be referred to wherever feasible. It will assist the engineer greatly if he follows their recommendations unless he has good reason to do otherwise. Materials conforming to such specifications are used more widely as a rule than those made according to less common ones; frequently they can be secured more easily, in smaller amounts, at a lower cost, and with less delay than the more "tailor-made" alloys which are usually totally unnecessary for the majority of engineering applications.

A.S.T.M. Standards are designated by a classification letter and number followed by the year of the latest revision. Thus B43-45 indicates standard 43 of classification B which was last revised in 1945. Standards which are only tentative, i.e., have been adopted only on a trial basis, are indicated by the letter T after the revision date, e.g., A206-45T. For simplicity, whenever A.S.T.M. Standards are mentioned in the text the date of last revision will be omitted, and it will be considered the reader's responsibility to refer to the latest form of any given standard before using it. The general classifications used for metallic materials are: "A" for ferrous metals; "B" for nonferrous metals; and "E" for miscellaneous subjects. The A.S.T.M. Standards may refer to either Specifications, Methods, Definitions, or Recommended Practices.

Certain of the A.S.T.M. Standards should be referred to for further information on some of the subjects already mentioned. Among these are:

- E7 Definition of Terms Relating to Metallography
- E3-T Methods of Preparation of Metallographic Specimens
- E2-T Methods of Preparation of Micrographs of Metals and Alloys (Including Recommended Practice for Photography as Applied to Metallography)
- E6 Definition of Terms Relating to Methods of Testing
- E10 Method of Test for Brinell Hardness of Metallic Materials
- E18 Methods of Test for Rockwell Hardness and Rockwell Superficial Hardness of Metallic Materials
- E48-T Hardness Conversion Tables for Steel

- E23-T Methods of Impact Testing of Metallic Materials
- E8 Methods of Tension Testing of Metallic Materials
- E21 Recommended Practice for Short-Time Elevated-Temperature Tension Tests of Metallic Materials
- E4 Methods of Verification of Testing Machines
- E9-T Methods of Compression Testing of Metallic Materials
- E22 Recommended Practice for Conducting Long-Time High-Temperature Tension Tests of Metallic Materials
- B63 Method of Test for Resistivity of Metallic Materials
- B95 Method of Test for Linear Expansion of Metals
- E15-T Methods of Radiographic Testing of Metal Castings
- A127 Definition of Terms, with Units and Symbols, Relating to Magnetic Testing

*For Further Study Refer to*

1. *Metals Handbook*: American Society for Metals, Cleveland, Ohio, 1939 (usually published triennially). A new edition will appear in 1948.
2. *Inspection of Metals*, by H. B. Pulsifer: American Society for Metals, Cleveland, Ohio, 1941.
3. *Metallographic Technique for Steel*, by J. R. Vilella: American Society for Metals, Cleveland, Ohio, 1937.
4. *Prevention of the Failure of Metals under Repeated Stress*, prepared for the Bureau of Aeronautics, Navy Department, by Battelle Memorial Institute: John Wiley & Sons, Inc., New York, 1941.
5. *The Hardness of Metals and Its Measurement*, by H. O'Neill: The Sherwood Press, Cleveland, Ohio, 1934.
6. *Hardness and Hardness Measurements*, by S. R. Williams: American Society for Metals, Cleveland, Ohio, 1942.
7. *Symposium on Radiography and X-Ray Diffraction*. American Society for Testing Materials, Philadelphia, Pa., 1936.
8. *Symposium on Radiography*: American Society for Testing Materials, Philadelphia, Pa., 1942.
9. *Industrial Radiography*, by A. St. John and H. R. Isenburger: John Wiley & Sons, Inc., New York, 1934.
10. *Magnaflux Aircraft Inspection Manual*, by F. B. Doane and W. E. Thomas: Photopress, Inc., Chicago, Ill., 1941.
11. *Materials Testing*, by E. J. Gilkey, G. Murphy, and E. O. Bergman: McGraw-Hill Book Company, Inc., New York, 1941.

12. *Heat Flow in Metals*, by J. B. Austin: American Society for Metals, Cleveland, Ohio, 1942.
13. *A.S.T.M. Standards, 1946*: American Society for Testing Materials, Philadelphia, Pa. (usually published triennially, with a yearly supplement).
14. *S.A.E. Handbook*: Society for Automotive Engineers, Inc., New York, 1947 (usually published annually).
15. *Symposium on Magnetic Particle Testing*: American Society for Testing Materials, Philadelphia, Pa., 1945.

## THE SIGNIFICANCE OF PURITY

ALTHOUGH HIGH-PURITY METALS AS SUCH ARE NOT USED commercially to any marked extent, some consideration of them is advisable because they represent what may be considered to be the normal state of the metallic type of material. A few comments on some of the usual effects of impurities also will be relevant because impurities are responsible for many of the abnormalities found in certain commercial alloys.

## PHYSICAL STATES OF A METAL

Under normal atmospheric pressure either the *gaseous*, *liquid*, or *solid* state of a pure metal may be stable, depending on the temperature. In any one of these states, the energy content will vary in a definite manner with temperature as determined by the specific heat. Furthermore, in the transition from one state to another there will be a discontinuous change in energy, the *latent heat of transformation*. This may be termed specifically a *latent heat of vaporization*, if the transformation is between the liquid and vapor states, or a *latent heat of fusion* if between the solid and liquid states.

## ATOM RELATIONSHIPS IN THE STABLE STATES

The radically different energies in these physical states are responsible for the different relationships existing between the atoms in each case. In the state possessing the highest energy, the gaseous or vapor state, the metals are known to be monatomic, each atom moving independently and with a high energy content. Gases have no definite shape, and occupy no definite volume.

In the medium energy or liquid state, some association apparently

## THE PURE METAL

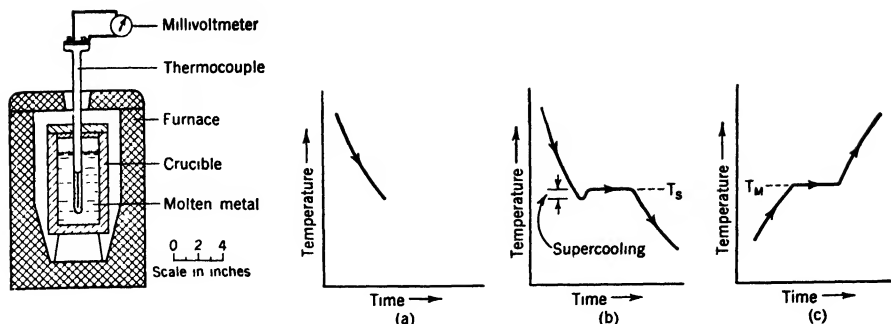


FIGURE 33. (Left) Diagrammatic cross section of apparatus suitable for determining heating and cooling curves. (After *Nat. Bur. Stand., Tech. Paper 170*, 1921.)

FIGURE 34. (Right) *a.* Cooling curve of a liquid metal. The cooling curve for a solid metal would be similar.

*b.* Solidification of a liquid metal as indicated on a cooling curve.

$T_S$  is the solidification temperature for the cooling conditions used. Some supercooling is indicated although it does not always occur.

*c.* Melting of a solid metal as indicated on a heating curve.  $T_M$  is the melting temperature for the heating conditions used.

exists between the atoms, but it is not as yet completely understood. Liquids have no definite shape, but they do occupy a definite volume.

In the lowest energy or solid state, however, the geometrical relationships between the atoms, at least, are better known because of X-ray diffraction studies. These indicate that the atoms vibrate about mean positions on a three-dimensional geometric pattern called a *space lattice*. The space lattice of each metal is known to have a characteristic size and symmetry, although the exact reasons which cause the atoms to crystallize and to remain on any particular lattice are still unknown.<sup>1</sup> Because of these factors, solids not only have a definite shape but also occupy a definite volume.

## THE THERMAL METHOD FOR DETERMINING ENERGY CHANGES

Some knowledge of these energies and of the change in the heat content of the metal on heating and cooling may be secured from measurements of temperature and time while a metal passes from the liquid to the solid state, or vice versa. This can be done most simply, as indicated in Fig. 33, by melting the metal in a crucible, inserting a protected thermocouple or some other suitable temperature-measuring device, and then taking simultaneous measurements of temperature and time as the metal cools. The

<sup>1</sup> Some of these factors are discussed in *Crystal Chemistry*, by C. W. Stillwell: McGraw-Hill Book Company, Inc., New York, 1938.



plot of such data is called a *cooling curve*, and the plot of similar data taken during a heating cycle would be termed a *heating curve*. Reference to A.S.T.M. Standard E14 will give information on the recommended practice for thermal analysis in the solid state, especially with respect to steel.

#### COOLING CURVES

A typical simple cooling curve for a pure metal, either in the solid or the liquid state, is shown in Fig. 34a.

However, when a transition, such as freezing or solidification for example, is encountered, the curve becomes more complex (Fig. 34b). The liquid metal first cools slowly and uniformly, as before, at a rate which is determined by its specific heat and thermal conductivity, and by the experimental conditions. If a very pure metal is cooled very slowly and outside disturbances are kept to a minimum, the liquid actually may be cooled to a temperature below its true freezing point before any solidification occurs. This phenomenon is known as *supercooling*. Regardless of whether supercooling takes place or whether solidification begins when the freezing temperature is reached, at some instant the first minute particle of a solid, i.e., a solidification nucleus, will form in the liquid, either by chance or because of the disturbing presence of some foreign material. Generally, more centers of solidification are found in impure than in pure metals. In changing from the liquid to the solid state, the latent heat of fusion will be liberated, and the temperature will be arrested at the freezing point of the metal concerned, i.e., solidification will take place at such a rate that the latent heat evolved will just balance the heat lost by radiation. If the temperature falls even slightly, because of the dissipation of this extra energy, more solid will form, either as new nuclei or by growth of the old ones; and the energy so released will restore the temperature to its equilibrium value. This process will continue at a constant temperature, as illustrated diagrammatically in Fig. 35, until solidification is complete. Once this has occurred, there is no additional energy to be released, and the temperature of the solid metal will fall steadily at a rate determined, as for the liquid, by its specific heat and thermal conductivity, and by the experimental conditions.

#### HEATING CURVES

Similar effects are found on heating except that the process is reversed, and superheating does not occur. The absorption of the latent heat of

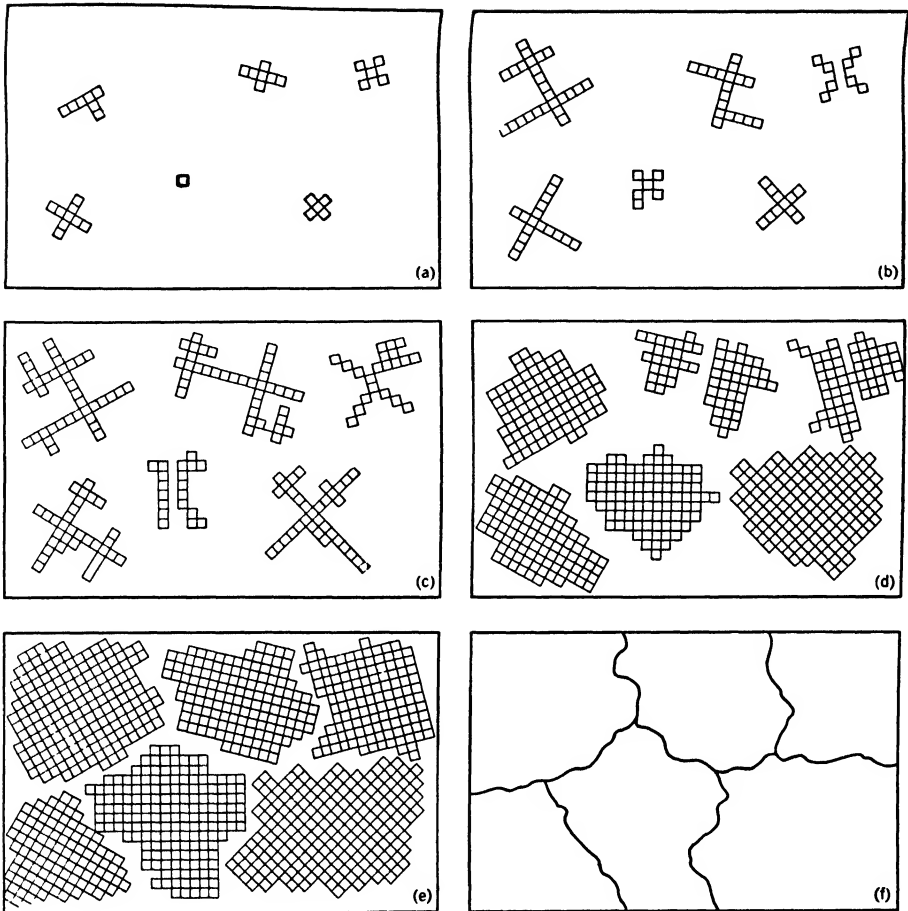


FIGURE 35. Diagrammatic representation of various stages in the process of solidification of a molten metal (after W. Rosenhain). (From *Engineering Materials and Processes* by W. H. Clapp and D. S. Clark, courtesy International Textbook Company.)

fusion at the melting point will keep the temperature constant until melting is complete (Fig. 34c).

#### GRAINS AND CRYSTALS

As a nucleus grows in size, new atoms will be added to it regularly according to a pattern which is determined in some manner by the space lattice upon which the metal is crystallizing. This process of growth will continue until it is obstructed by another grain (cf. Fig. 35). It will then either cease entirely, or else continue with some of the grains, the more



FIGURE 36. Idiomorphic crystals of the compound  $\text{SbSn}$  in an alloy of 70%  $\text{Sn}$ -30%  $\text{Sb}$ . Etched with nital.  $\times 100$ . (Photomicrograph by J. Caum.)

stable ones, absorbing the others. Grains formed in this manner, the external shape of which is determined by chance external conditions, are said to be *allotriomorphic* or *equiaxed* if all three dimensions are nearly the same, or *columnar* if elongated. In them, the atomic arrangement is just as regular as it is in a natural crystal which grows without external interference, and thus is able to develop its characteristic crystal faces.

Under some conditions, however, grains which do possess regular geometrical shapes, such as those shown in a bearing metal in Fig. 36, are formed within a solid alloy. These grains are said to be *idiomorphic*.

#### GRAIN BOUNDARIES

The exact nature of the regions at which adjacent grains come in contact is not known. However, some evidence has been presented<sup>2</sup> which indicates that many of these regions differ in chemical activity, and that they may differ in composition, from the remainder of the grain. Because each grain grows independently, in a manner determined largely by chance, it ordinarily will be oriented completely at random with respect to its neighbors.

Since each atom is subjected to a series of forces from its individual neighbors, it should be clear that, in regions near the grain boundaries upon which these differently oriented regions abut (cf. Fig. 35), the atom arrangements would be expected to be distorted drastically because of the complexity of the forces acting on them. Such an effect could account to a large extent for the different physical and chemical properties of the grain boundary material, although direct quantitative evidence of its existence still is lacking.

#### GRAIN GROWTH AND GRAIN SIZE

In order that grains may grow, energy is required to increase the atomic mobility sufficiently. The greater the intensity of this energy, or the higher

<sup>2</sup> See, for example, G. R. Dean and W. P. Davey, *Trans. A.S.M.*, 26, 1938, 267-276; E. H. Dix, Jr., *Trans. A.I.M.E.*, 137, 1940, 11-40.

the temperature, the greater will be the rate at which growth will take place; and, as a rule, the larger will be the size of the resulting grains. Also important is the number of growth nuclei, or centers of growth, on which the new grains can form. The greater this number, the greater will be the tendency toward a small grain size, and the smaller this number the greater will be the tendency toward a large grain size, although, as mentioned previously, under suitable conditions many small grains can be absorbed or can coalesce to form the larger ones.

#### THE EQUILIBRIUM STATE

Equilibrium signifies a state of rest. With regard to physical or chemical change, it means that a given reaction has proceeded as far as it can with the energy available, and that no further change can or will occur as long as the existing conditions are maintained. The rate of attainment of equilibrium will depend on the intensity of the available energy; and it is, therefore, a function of the temperature at which the change is taking place.

#### ATTAINMENT OF EQUILIBRIUM DURING HEATING OR COOLING

For a *spontaneous* reaction taking place during heating, the higher the temperature at any instant the more rapidly equilibrium conditions will tend to be approached. However, the attainment of essential equilibrium will depend on both the maximum temperature and the time of holding at that temperature. The rate of heating will affect only the instantaneous conditions, and cannot influence the final results unless the maximum temperature is not maintained for a sufficiently long time. Furthermore, once equilibrium, or essential equilibrium, has been established, subsequent cooling can exert little or no effect in reasonable time intervals since it is bound to lead to a state of lower energy intensity and atomic mobility, and hence the reaction will stop.

When the spontaneous reaction takes place during cooling the effect is somewhat different even though the same general principles apply. During cooling, equilibrium also will tend to be attained most rapidly under those conditions which will make available the greatest intensity of energy for the longest period of time. This now means, however, either holding at a temperature just under that at which the reaction occurs, or else cooling very slowly.

An additional complicating factor is introduced in reactions which do

not take place spontaneously, such as those occurring in the heat-treatment of steel. Many reactions, especially in solid alloys or impure metals, are sluggish, and require a considerable driving force to initiate them. Since this driving force generally is secured by increasing the amount of supercooling below the equilibrium reaction temperature, it can be seen readily that, in such cases, the two important effects, energy intensity and driving force, tend to exert opposing influences. The nature of the cooling reactions under these conditions will be discussed in more detail in a later chapter.

#### ATTAINMENT OF EQUILIBRIUM GRAIN SIZE DURING SOLIDIFICATION

In theory at least, therefore, the equilibrium solidification of a pure metal should result in the formation of relatively few grains. Practically, it almost invariably results in an extremely large grain size, which is essentially the same thing. The presence of impurities, either metallic or nonmetallic, generally tends to give a much smaller grain size because more nuclei will be formed, and the average grain size thus will be smaller.

Should the rate of cooling be increased, the tendency to form additional nuclei, which will serve as centers of crystallization and growth, also is increased so that a larger number of grains per unit volume would be expected. In addition, the more rapid the rate of cooling the less time the material would remain at any one temperature, and the less time would thus be available for attaining equilibrium. The combination, therefore, of a large number of nuclei with a constantly decreasing intensity of available energy and rate of attainment of equilibrium tends to result in a small grain size.

Hence, the general statement may be made that, *under normal conditions*, when crystallization nuclei are formed on cooling, the slower the rate of cooling the larger will be the resulting grain size; and the more rapid the rate of cooling the smaller will be the resulting grain size. Some modification of this statement must be made, naturally, whenever conditions are changed in such a way as to result in an abnormally large number of nuclei or an abnormally slow rate of attainment of equilibrium.

It should be pointed out also that, merely by forming, the grains automatically attain a size that will be in essential equilibrium for some temperature range. Consequently they can grow only until this temperature is reached on cooling. Once this occurs, growth will cease until the intensity of energy is increased by reheating to a higher temperature. Since the

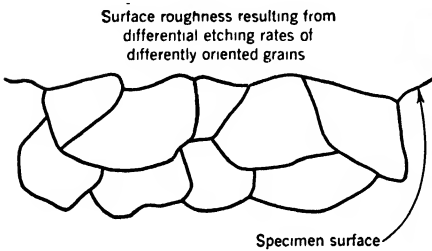
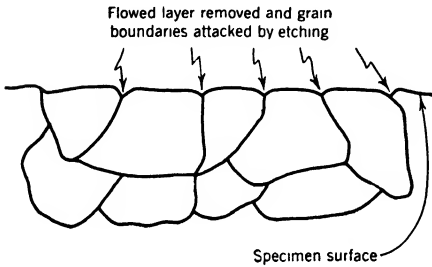
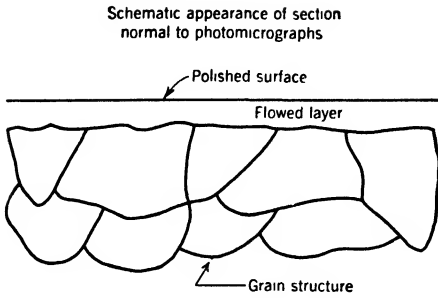


FIGURE 37. Stages in the etching of a metallographic specimen of commercially pure ingot iron.  
*a. (Top)* Specimen “as polished.” Dark spots are largely oxide inclusions. *b. (Middle)* Polished specimen after light etch. Dark lines are grain boundaries. *c. (Bottom)* Polished specimen after heavy or contrast etch. All grains have essentially the same composition but etch at different rates because of differences in orientation.

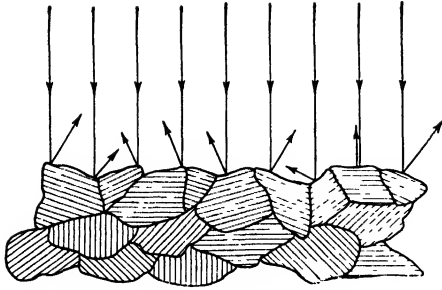


FIGURE 38. Schematic illustration of reflection of parallel rays of light from the surface grains of a specimen given a contrast (heavy) etch. (After W. Rosenhain.) The more nearly the reflected rays are parallel to the incident rays the brighter the surface of the grain will appear under the microscope.

grains are rigid structural entities, they cannot decrease in size, automatically, as the temperature falls.

### ETCHING

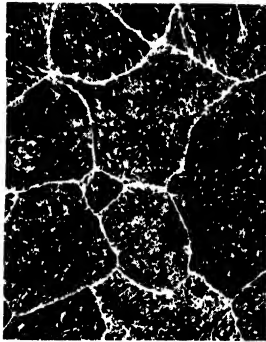
In order to make visible the grain structure of a metal, some method of differentiating between the different grains of which it is composed must be employed. If certain of the grains vary markedly in hardness, as is the case with alloys that are merely mechanical mixtures of several constituents, such as lead and copper, or graphite or slag and iron, a simple polishing operation may suffice by producing a difference in level between them. Usually, however, some form of chemical attack also is required. Such an attack, when properly controlled, is called etching. Tentative methods of preparation of metallographic specimens have been outlined completely in A.S.T.M. Tentative Standard E3-T.

Except for cases such as those already mentioned, a polished metallic surface is completely lacking in detail (Fig. 37*a*), because of the presence of a flowed surface layer and the lack of sufficient resolving power in the microscopes available, even though many grains, differing either in composition or in orientation, may be cut by it. Light etching tends first to dissolve this flowed layer and then to attack the grain boundaries (Fig. 37*b*), revealing them as thin lines. As etching is continued, these boundaries will thicken somewhat and the grains themselves will be attacked to an extent dependent, at least partially, on their orientation. Hence, a heavy or contrast etch (Fig. 37*c*) not only may result in appreciable differences in level between neighboring grains, but also frequently will produce markedly different shadings, because of the reflection or lack of reflection of light from the surface to the eye of the observer as illustrated in Fig. 38. This can result from variations in orientation, with concomitant differences in etching rates, even though all the grains are identical in composition. If the grains differ in composition, the contrast will be even more striking because of the electrochemical acceleration of the etching.

The rate of etching will depend not only on the solution employed, and the composition of the material, but also on the uniformity of the material.



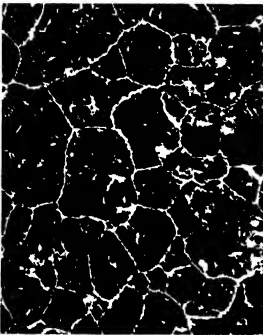
*a*-No. 1 grain size



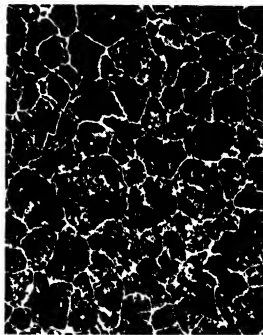
*a*-No. 2 grain size



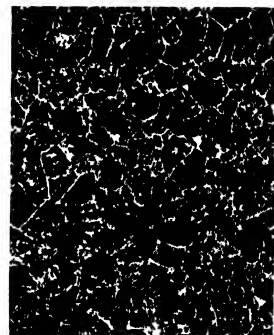
*a*-No. 3 grain size



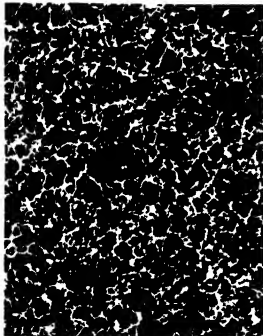
*a*-No. 4 grain size



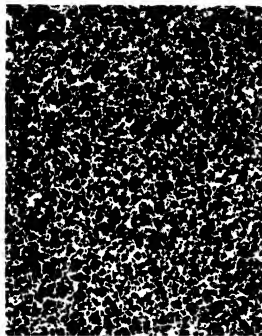
*a*-No. 5 grain size



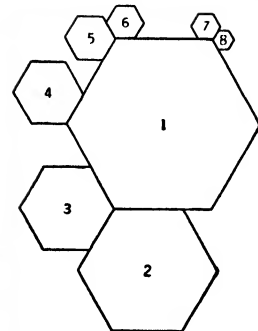
*a*-No. 6 grain size



*a*-No. 7 grain size



*a*-No. 8 grain size



*b*

FIGURE 39. A.S.T.M. Standards for estimating the (austenitic) grain size of steel. *a*. Photomicrographs of samples carburized at 1700 F (930 C) for 8 hr and slowly cooled to develop the cementite network. Etched with nital.  $\times 100$ . (Photomicrographs courtesy The Timken Roller Bearing Company.) *b*. Standard grain sizes idealized as uniform hexagonal areas. (Courtesy Heppenstall Company, 4620 Hatfield Street, Pittsburgh 1, Pa., from whom similar transparent plastic grain size cards can be secured upon request.)



As already pointed out, inhomogeneity, resulting from strain, impurity, or a difference in composition, will tend to produce accelerating conditions. In general, although there are many exceptions, pure metals are more difficult to etch than either impure metals or alloys of the same type.

#### MEASUREMENT OF GRAIN SIZE

Some knowledge of the size of the grains of which metals and alloys are composed is usually desirable since it can be determined easily and has been found to correlate well in many metals with hardness, tensile strength, workability, and other significant properties, such as machinability and reaction to heat-treatment. Such correlations as can be established hold only for the one particular metal or alloy, however, and have no real significance in comparing different materials. Three general methods for determining grain size from a polished and etched metallographic specimen are in common use today. All of them are discussed in considerably greater detail in A.S.T.M. Tentative Standard E2-T.

**DIRECT COMPARISON WITH STANDARDS** The American Society for Testing Materials has prepared a set of standard micrographs, similar to those shown in Figs. 39 and 40, of a series of grain sizes for both ferrous (A.S.T.M. Standard E19) and nonferrous (A.S.T.M. Tentative Standard E2-T) materials. The two differ in the system of nomenclature used, the ferrous alloys usually being measured at a magnification of  $100\times$ , and rated by reference to a logarithmic series of eight arbitrary areas (grains per square inch); whereas the nonferrous materials are based upon a linear diameter scale measured at  $75\times$ , and expressed as average grain diameter in millimeters. Grain sizes in aluminum alloys generally are referred to still another set of standard photomicrographs used by the Aluminum Company of America. In aluminum alloys grain volume seems to correlate better than grain diameter or area.

**MEASUREMENT OF AVERAGE GRAIN DIAMETER** Actual measurement of the average diameters of a large number of grains, either by means of a graduated eyepiece or by projection upon a ground glass screen, is a method frequently used, although it is apt to be somewhat tedious.

**THE JEFFRIES METHOD** In the Jeffries method the number of grains falling within, and on, a circle 79.8 mm in diameter (5000 sq mm area) drawn on a ground glass screen, is measured and used to determine the grain size. This gives the most accurate data, but is extremely tedious to carry out successfully, and the greater precision is seldom worth the additional trouble involved.

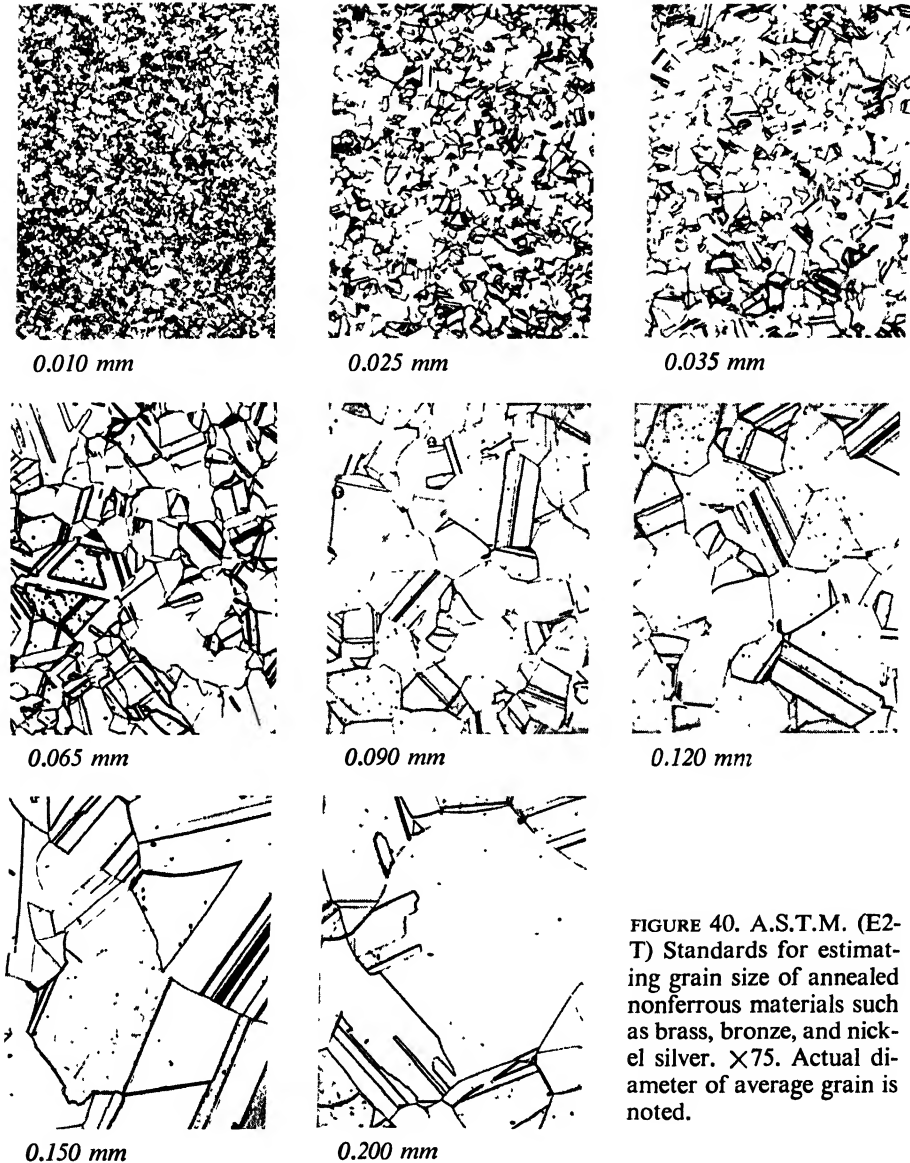


FIGURE 40. A.S.T.M. (E2-T) Standards for estimating grain size of annealed nonferrous materials such as brass, bronze, and nickel silver.  $\times 75$ . Actual diameter of average grain is noted.

Since all three methods are apt to give quite similar results, the most simple one generally is used industrially. It must always be remembered, however, that such a count is two dimensional, even though the actual grains involved are three dimensional. Therefore, for precise work a large number of readings on three mutually perpendicular faces should be taken, regardless of the method used, in order that a proper statistical average of the actual grain size or actual grain diameter may be secured.

## SPACE LATTICES

The space lattices of metals can be determined by X-ray diffraction methods<sup>3</sup> which differ from the radiographic method previously mentioned in connection with nondestructive testing. In general, the space lattices of most metals are rather symmetrical in nature. Two of the commonest types are variations of the *simple cubic lattice*, a unit of which is illustrated in Fig. 41. In this lattice each corner of each unit cube is occupied by a single atom. Since the atomic domains are presumably packed as closely as possible, it can be seen that each unit cube contains but one atom. Each of the eight corners is shared by seven other unit cubes, and, therefore, only one eighth of each corner atom can be considered as belonging to any specific unit cell.

## BODY-CENTERED CUBIC LATTICE

If two of these simple cubic lattices are so interlocked that the corners of one fall exactly in the centers of the cubes of the other, as shown in Fig. 42, the first of the common metallic lattices, the body-centered cubic lattice results. Each cube now contains two atoms, one in the center and one from the simple cubic structure, i.e., eight corners with one eighth of an atom from each.

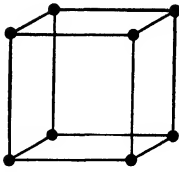
At room temperature, many of the *stronger* common metals, such as *chromium, iron, molybdenum, tantalum, tungsten, vanadium, and zirconium*, crystallize in this lattice. *Manganese* has a similar, but much more complex structure.

## FACE-CENTERED CUBIC LATTICE

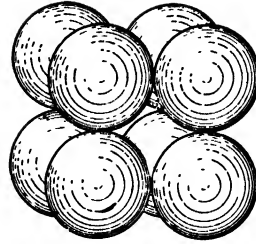
If an atom is placed in the center of each face of a simple cubic lattice, or if two simple cubic lattices are expanded in one dimension until their height is 1.414 times the side of their base and then interlocked, as in the body-centered cubic lattice, the face-centered cubic lattice shown in Fig. 43 will result. The unit cube now contains four atoms, viz., one from the simple cubic lattice and one half of an atom from each of the six faces of the cube.

At room temperature, many of the more *ductile* metals, such as *aluminum, copper, gold, iridium, lead, nickel, palladium, platinum, rhodium, and silver*, crystallize on this type of space lattice.

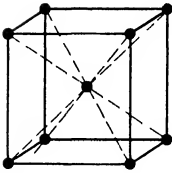
<sup>3</sup> See, for example, *Applied X-Rays*, by G. L. Clark: McGraw-Hill Book Company, Inc., New York, 1940; *Structure of Metals*, by C. S. Barrett: McGraw-Hill Book Company, Inc., New York, 1943.



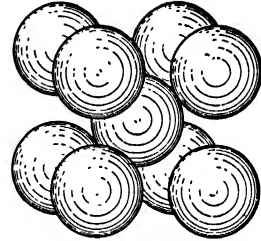
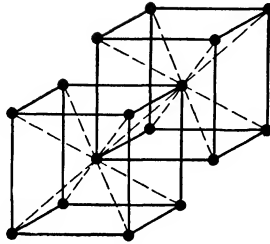
(a) Atom Positions Represented By Points



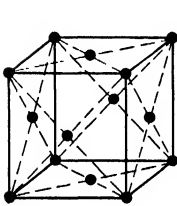
(b) Atoms Represented By Spheres



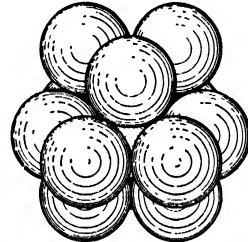
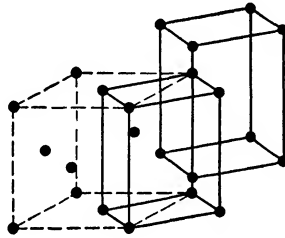
(a) Atom Positions Represented By Points



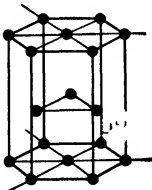
(b) Atoms Represented By Spheres



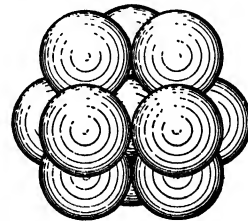
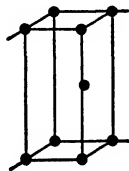
(a) Atom Positions Represented By Points



(b) Atoms Represented By Close-Packed Spheres. Note the relationship between successive close-packed planes as compared with the hexagonal lattice below



(a) Atom Positions Represented By Points



(b) Atoms Represented By Close-Packed Spheres. Note the relationship between successive close-packed planes as compared with the face-centered lattice above

FIGURE 41. (Row 1) The simple cubic lattice.

FIGURE 42. (Row 2) The body-centered cubic lattice.

FIGURE 43. (Row 3) The face-centered cubic lattice.

FIGURE 44. (Row 4) The close-packed hexagonal lattice.

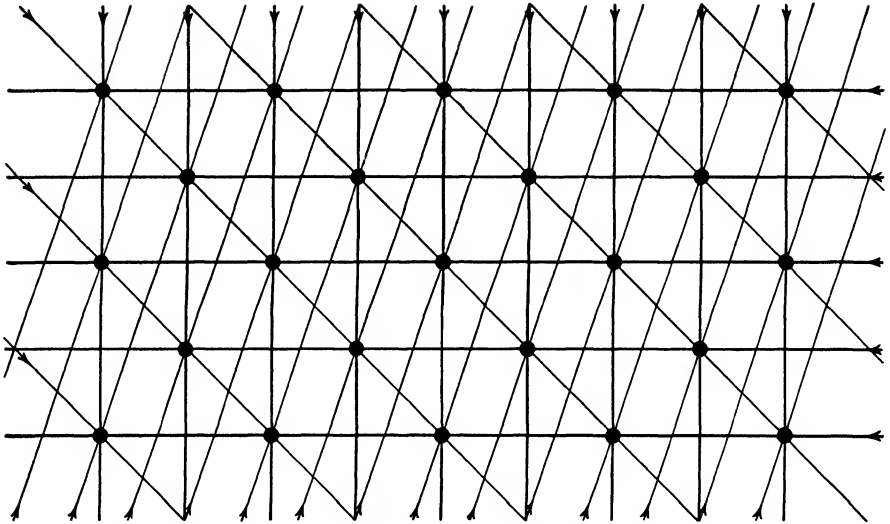


FIGURE 45. Several families of crystallographic planes represented as parallel-line traces on a two-dimensional projection of a face-centered cubic space lattice.

The arrangement of atoms in this lattice is one of the two ways in which spheres can be packed together most closely (Fig. 43*b*).

#### CLOSE-PACKED HEXAGONAL LATTICE

The second method for close-packing spheres is based upon the hexagonal arrangement illustrated in Fig. 44. Taking the hexagonal cell as a unit, this cell will contain six atoms, viz., one sixth from each of the six corners of the basal faces, one half from the centers of each of these basal faces, and three from the interior of the unit cell.

At room temperature some of the more common metals crystallizing in this lattice are: *beryllium*, *cadmium*, *magnesium*, *titanium*, *zinc*, and *zirconium*. *Mercury*, when solid, also crystallizes in it.

#### CRYSTALLOGRAPHIC PLANES

Because of the regular spacing of the atoms in solid metals upon a space lattice, it is possible, from purely geometrical considerations, to pass through that lattice families of equidistant parallel planes upon which the atoms will be regularly, but more or less densely, distributed. Several such families are illustrated as lines in Fig. 45 on a two-dimensional projection of a space lattice. These planes are called the crystallographic planes because of their relationship to similar planes used in mineralogy to

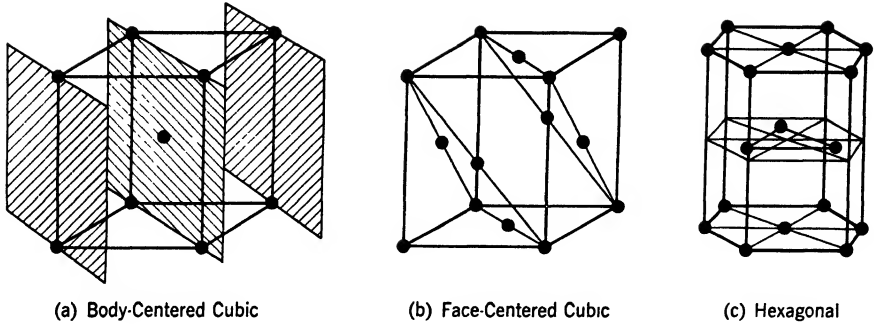


FIGURE 46. Examples of close-packed planes for the three simple metal space lattices.

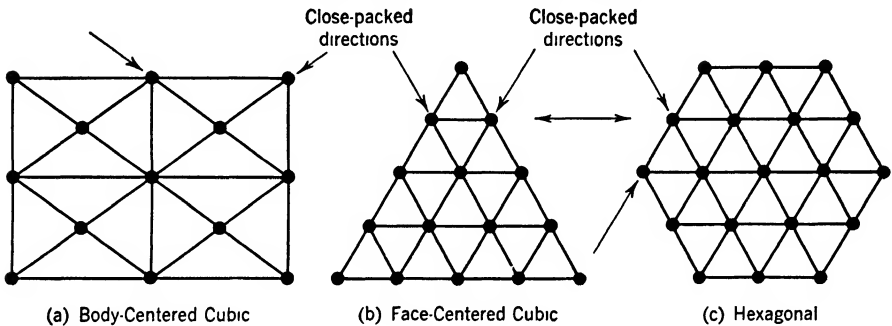


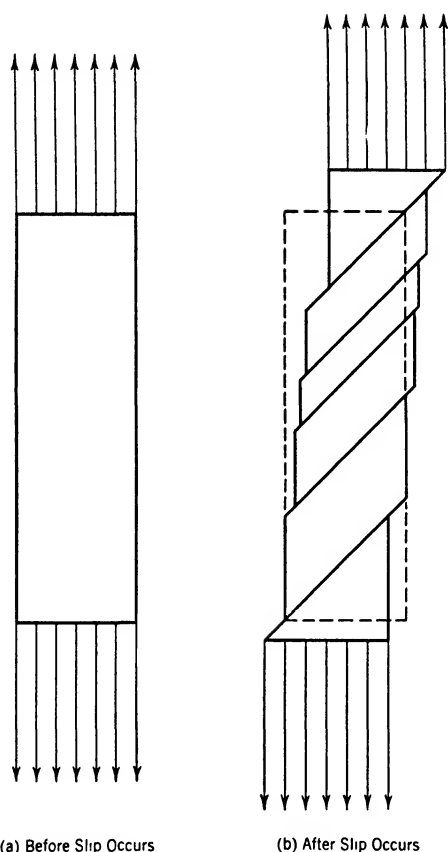
FIGURE 47. Atom arrangements on typical close-packed planes for the three simple metal space lattices. Note that the closest approach of the atoms is along the close-packed directions, and that the atom positions on any one close-packed plane are identical for both the face-centered cubic and the hexagonal lattices.

describe crystal faces, and usually are referred to by indices secured by taking the reciprocals of their intercepts upon certain axes of symmetry in the lattice.

#### CLOSED-PACKED PLANES

Since these crystallographic planes can pass through the lattice in any direction, the density of packing on any plane of a given family will be determined by the arrangement of atoms on that lattice. Obviously, if the atoms are packed most densely on each of a given family of planes, then successive planes of that family must also be spaced most widely. Planes of this type are known as close-packed planes. In other families of planes, the members are spaced more closely and the density of packing on each is, consequently, lower.

A typical series of close-packed planes for each of the three simple metal space lattices is indicated in Fig. 46. In the hexagonal system, there is only one set of such planes, parallel to the base of the hexagon; but in both



(a) Before Slip Occurs

(b) After Slip Occurs

FIGURE 48. Schematic representation of the process of slip in metallic deformation. (A third stage, not shown, consisting either of rotation or of slip in another direction, would be required to realign the tensile forces acting on each end.)

in which the applied stress is transmitted to it by its neighbors. Since every metal specimen is an aggregate of a large number of minute crystals, each of which usually is oriented entirely at random with respect to its neighbors, it should be clear that, practically, deformation must be a very complex process.

Two general mechanisms are helpful in explaining the deformation of the individual crystals: *slip* and *twinning*. Although these processes will account satisfactorily for many of the geometrical changes which are known to occur, they have not succeeded as yet in explaining the property changes, such as work-hardening, which are more important from an

<sup>4</sup> See, for example, *Distortion of Metal Crystals*, by C. F. Elam: Oxford University Press, New York, 1935.

of the cubic lattices, there are several, only one of which is illustrated although the locations of the others should be readily apparent.

#### CLOSE-PACKED DIRECTIONS

The arrangement of the atoms on a typical close-packed plane of each of the three lattices is shown in Fig. 47. It will be noticed that along certain lines in these planes the atoms again are packed more closely than along others. These are the close-packed directions which lie in the close-packed planes. Both the close-packed planes and the close-packed directions are significant in modern theories of deformation.<sup>4</sup>

#### DEFORMATION WITHIN THE GRAINS OF A METAL AGGREGATE

Under the action of external forces, each crystal of an aggregate will tend to deform or change its shape in a manner which will depend upon its own lattice orientation, as well as upon the directions

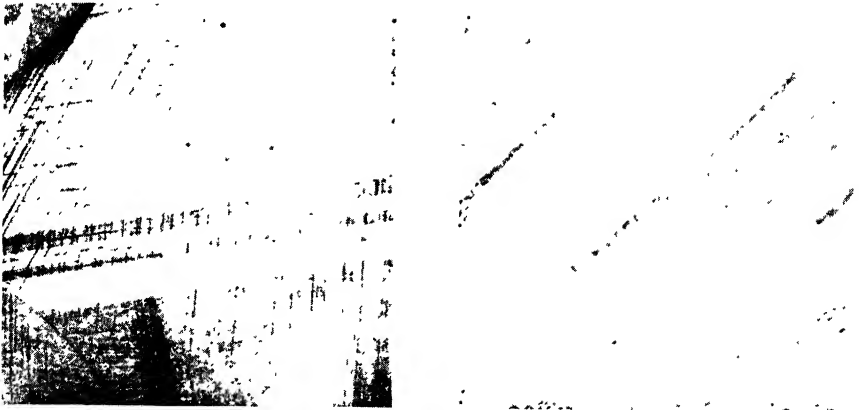


FIGURE 49. (*Left*) Slip lines in a coarsely crystalline brass. Etched with  $\text{NH}_4\text{OH} + \text{H}_2\text{O}_2$ .  $\times 200$ .

Most of the area shown is occupied by a single crystal within which two sets of slip lines appear. Notice how the secondary slip lines have produced a displacement of the primary slip lines in certain regions, and how the secondary slip lines change direction on passing through the annealing twin bands. (Photomicrograph courtesy R. M. Brick.)

FIGURE 50. (*Right*) Displacement of grain boundaries by slip in an alloy of 90%Al-10% Mg. Etched with  $\frac{1}{2}\%$  HF.  $\times 500$ .

The specimen was given a solution heat-treatment, cold-rolled, and then given a precipitation treatment of  $\frac{1}{2}$  hr at 400 F (205 C). The black slip lines, showing a clear-cut boundary displacement in several places, can be seen here because of the fine precipitate produced by the last heat-treatment. (Photomicrograph courtesy R. M. Brick.)

engineering viewpoint. No theories are available as yet which will do this entirely satisfactorily.

### SLIP

The mechanism generally believed to explain slip is illustrated in Fig. 48. Under the action of a sufficiently large stress, blocks of crystalline material apparently slide over their neighbors along planes which are usually the close-packed planes, and in directions which are almost invariably the close-packed directions. The thickness of these blocks will vary, and the reason why only certain of the eligible planes or directions should yield in this manner is, as yet, somewhat obscure, although many theories explaining it have been proposed. Deformation by slip seems to be independent of the stress normal to the slip plane; it proceeds only along certain planes and in certain directions; it is self-stopping; and it results in definite work-hardening, which affects not only the specific plane upon which it occurs but also inactive planes. Once slip has occurred, the crystal is hardened and strengthened as a whole rather than only in the regions of the active slip planes.



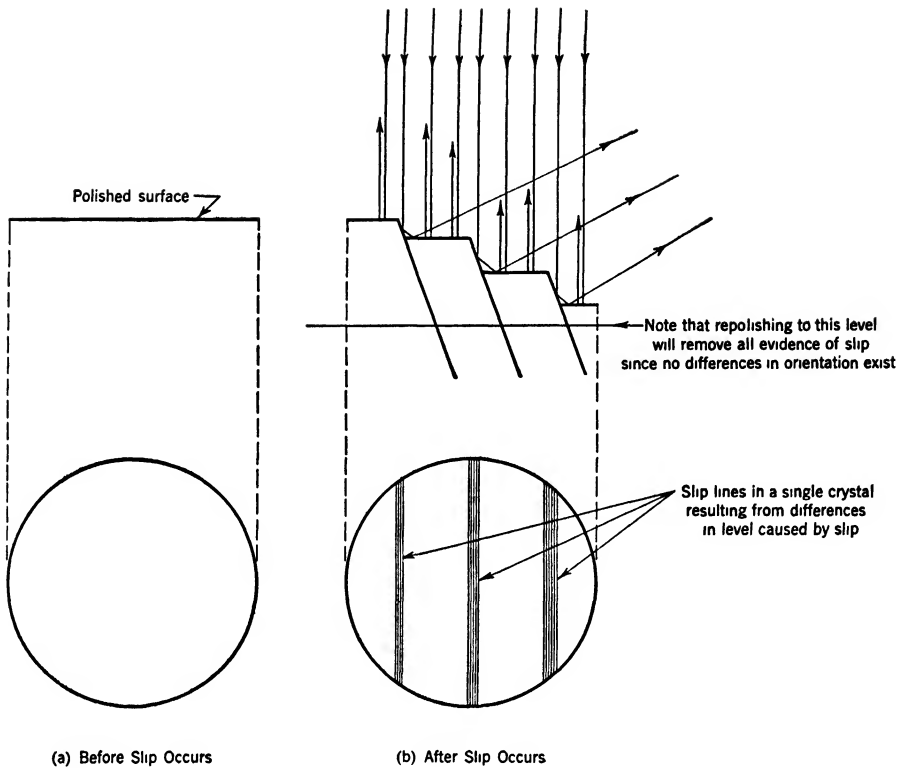


FIGURE 51. Schematic explanation of the formation of slip lines in a metal crystal.

### SLIP LINES

If a polished metal surface is deformed, the effects of the block movement, which has been called *slip*, can be seen readily. Long straight lines appear, running across each crystal, as illustrated in Fig. 49. Sometimes, also, actual displacement of the crystal with respect to neighboring grains can be observed (Fig. 50). The reasons for these slip lines easily can be understood from the diagram of Fig. 51.

Since no major difference in orientation results from this type of deformation, simple repolishing of the surface will remove the differences in level and thus eliminate the slip lines.

### TWINNING

Twins, in metal crystals, are mirror images, with respect to lattice orientation, produced on either side of a neutral plane called the *composition plane* (Fig. 52). The composition plane may or may not be a close-

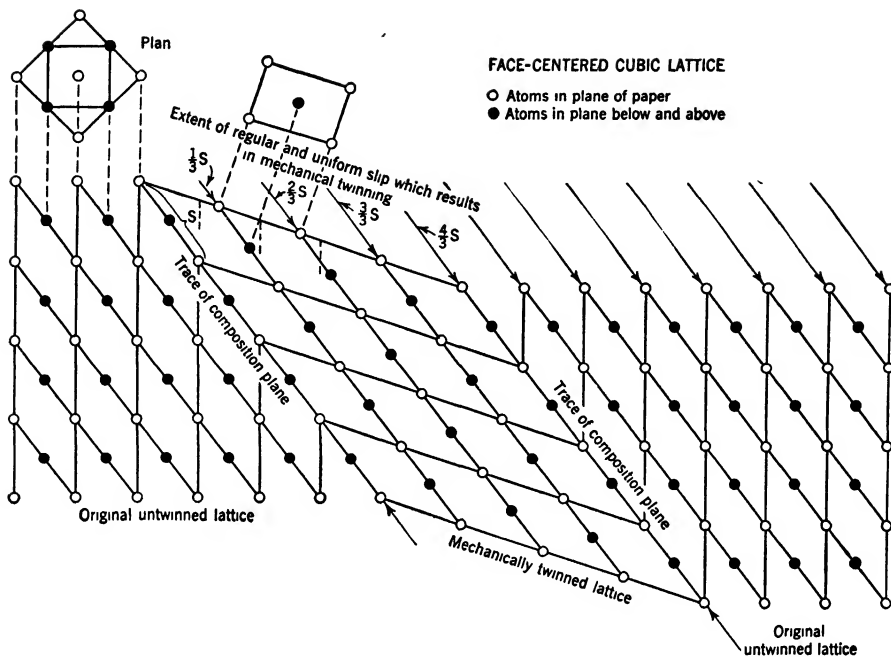


FIGURE 52. Diagrammatic explanation of the formation of a twinned orientation in a face-centered cubic lattice by a process of regular and uniform slip. (After C. H. Mathewson and K. R. Van Horn, *Trans. A.I.M.E.*, **89**, 1930.)

packed plane. The actual mechanism of twin formation is not known although satisfactory geometrical explanations have been given in most instances.<sup>5</sup> Twins may be produced either by deformation, known as *mechanical twins*, or by heat-treatment, called *annealing twins*.

#### MECHANICAL TWINNING

Mechanical twins, such as those in zinc (Fig. 53a), the *Neumann bands* in iron (Fig. 53b), or the *deformation lines* in copper and brass (Fig. 53c), may or may not be perfectly straight, depending to a large extent on the method by which they were produced. This process often displaces the grain boundary (Fig. 54). A definite difference in orientation exists between the twinned and the untwinned portions (Fig. 55) so a simple repolishing of the specimen will not remove the bands, although subsequent etching probably will be required to show them up distinctly.

Mechanical twins are usually of little significance with respect to deformation except for metals crystallizing in the hexagonal and some of the

<sup>5</sup> See, for example, C. H. Mathewson, *Trans. A.I.M.E., Inst. Met. Div.*, **78**, 1928.

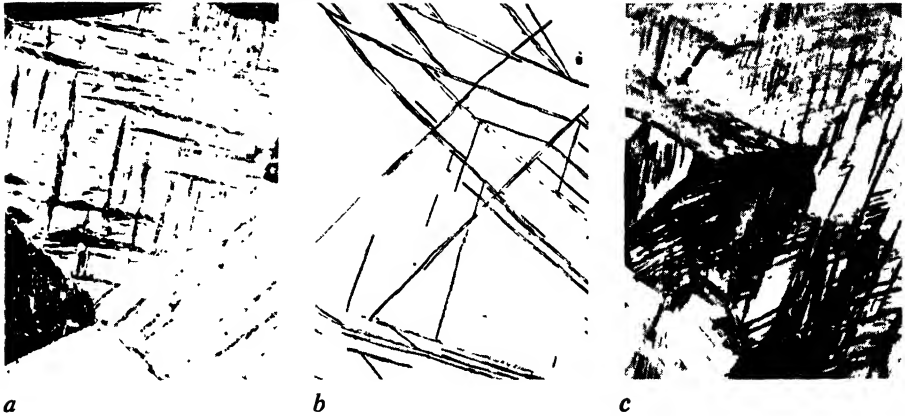


FIGURE 53. Various forms of mechanical twinning in metals.  
*a.* Mechanical twins in commercial zinc. Etched with nitric and chromic acids.  $\times 100$ . (Photomicrograph by B. S. Norris.)  
*b.* Neumann bands in electrolytic iron. Etched with nital.  $\times 250$ . (Photomicrograph courtesy Research Laboratory, General Electric Company.)  
*c.* Deformation lines in a bronze. Etched with  $\text{NH}_4\text{OH} + \text{H}_2\text{O}_2$ .  $\times 200$ . (Photomicrograph by L. Litchfield.)

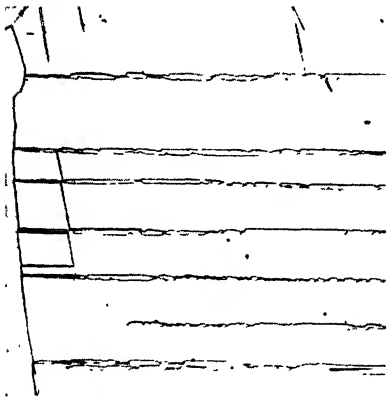


FIGURE 54. Displacement of grain boundary by Neumann bands in electrolytic iron. Etched with nital.  $\times 250$ , originally, reduced about one half in reproduction. (Photomicrograph courtesy Research Laboratory, General Electric Company.)

more complex lattices where, because of the relatively small number of possible slip planes, they are an important factor in facilitating the deformation of some orientations. In the cubic metals, they serve usually merely as an indication that mechanical deformation has taken place.

#### ANNEALING TWINNING

Annealing twins (Fig. 56) are invariably straight-sided, and are usually much thicker than mechanical twins. The exact mechanism of their formation is not known although they are particularly prominent in nearly all the face-centered cubic metals, with the exception of

aluminum, and their alloys. They offer a simple method for identifying, qualitatively, most of the metals of this type.

As might be expected from the twinned orientation, slip bands will change direction upon passing through an annealing twin band (Fig. 57).

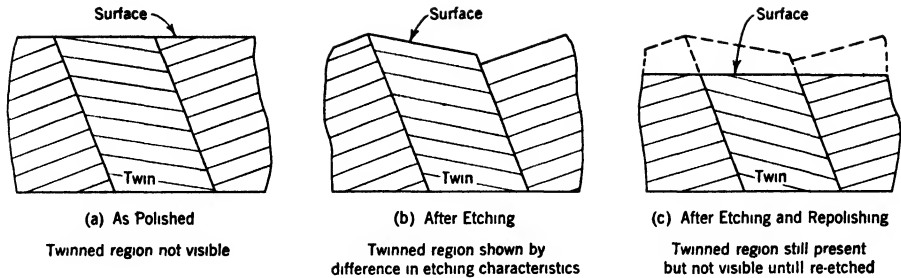


FIGURE 55. Diagrammatic representation of effect of etching and repolishing on twins in a metal crystal.

The twin bands probably exert some strengthening effect upon the aggregate, comparable possibly to that of a smaller grain size. Since the orientations of a grain and its twins are different, even though related, they will reflect light differently when heavily etched (Fig. 56*b*). Annealing twins cannot be removed by repolishing, any more than can mechanical twins, since a definite difference in orientation exists. A subsequent etch will disclose them exactly as before.

#### GRAIN BOUNDARY DEFORMATION IN A METAL AGGREGATE

It frequently has been observed that, in addition to the deformation within the grains, there is some movement between the grains themselves. This results often in the roughening of the surface of a deformed piece of metal, especially when the grains, of which it is composed, are large. In formed metal sheets such an effect results in what often is called an *orange peel* surface (Fig. 58).

The importance of this grain boundary deformation, compared to that within the grains, seems to vary both with the rate of deformation and with the temperature. The combination of very slow rates of deformation and increased testing temperatures tends to result in intercrystalline rather than in transcrystalline fracture. Consequently, under some conditions at least, the movement between the grains must be relatively important.

#### EQUICOHESIVE TEMPERATURE

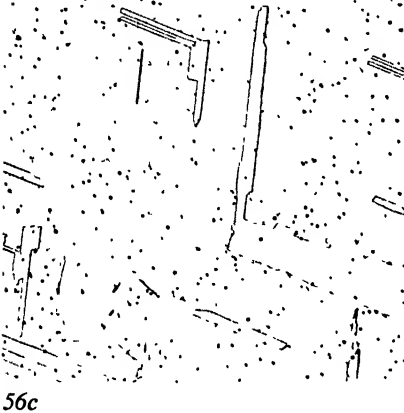
The tendency for the grain boundaries to be stronger, at lower temperatures and faster rates of application of load, than the material within the grains has caused some investigators to propose the existence of a temperature or range of temperatures which they have termed the equi-



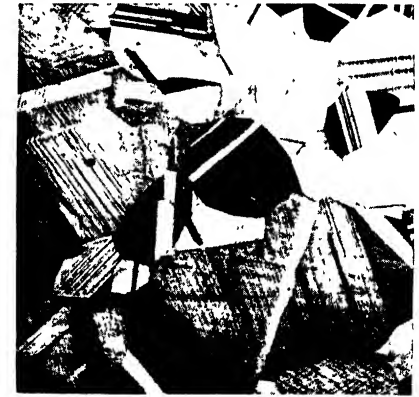
56a



56b



56c



57

FIGURE 56a. Annealing twins in soft brass. Etched with  $\text{NH}_4\text{OH} + \text{H}_2\text{O}_2$ , lightly.  $\times 100$ . *b.* Annealing twins in soft brass. Etched with  $\text{NH}_4\text{OH} + \text{H}_2\text{O}_2$ , heavily.  $\times 100$ . *c.* Annealing twin bands in single crystal of pure copper to which 0.2% phosphorus and 0.005% sulfur had been added. Sample was cold-rolled 40% and annealed 30 min at 1650 F (900 C). Etched with  $\text{NH}_4\text{OH} + \text{H}_2\text{O}_2$ .  $\times 75$ . (Photomicrograph courtesy Research Department, American Smelting and Refining Company.)

FIGURE 57. Change in direction of slip lines in brass on passing through annealing twin bands. Etched with  $\text{NH}_4\text{OH} + \text{H}_2\text{O}_2$ .  $\times 50$ . See also Fig. 49. (Photomicrograph courtesy R. M. Brick.)



FIGURE 58. "Orange peel," caused by coarse grains, on the surface of drawn steel. (Photographs courtesy The American Rolling Mill Company.)

cohesive temperature.<sup>6</sup> As illustrated schematically in Fig. 59, at temperatures lower than this range the grain boundary material is stronger than that within the grains, whereas it is weaker at those temperatures higher than it. Clearly, this explanation makes no mention of the factor, *rate of straining*, which must have an importance at least comparable with that of temperature. Although the concept of an equicohesive temperature is a convenient one, especially in discussing such things as deformation, its exact significance is somewhat obscure, and direct experimental evidence of it is still lacking.

#### AMORPHOUS METAL HYPOTHESIS

In some temperature ranges many amorphous materials, such as pitch, for example, are in reality supercooled liquids rather than crystalline solids, even though they have the external appearance of solids. Such materials behave in a manner somewhat similar to that attributed to the grain boundary material in metals, viz., become markedly weaker and less viscous with increasing temperature. Because of this, it has been suggested that an amorphous or disorganized material exists at the grain boundaries<sup>7</sup> and is formed along the crystallographic planes which are deformed by slip. Although this concept, too, is convenient for explaining some of the effects found experimentally in work on deformation, and especially the phenomenon of work-hardening, definite quantitative evidence of its validity is lacking. In fact, the available information seems to cast considerable doubt on its existence.

#### COLD-WORK ✓

When a metal is deformed in or below a temperature range in which work-hardening occurs, the deformation is known as cold-work regard-

<sup>6</sup> See, for example, *The Science of Metals*, by Z. Jeffries and R. S. Archer: McGraw-Hill Book Company, Inc., New York, 1924.

<sup>7</sup> See, for example, *Aggregation and Flow of Solids*, by G. T. Beilby: Macmillan and Company, Ltd., London, 1921.

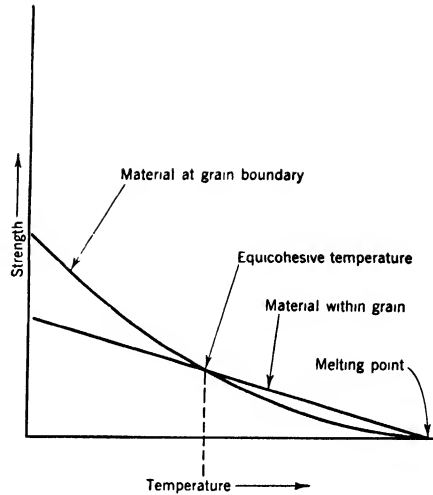


FIGURE 59. Schematic illustration of the concept of an equicohesive temperature. (After Z. Jeffries and R. S. Archer, and C. F. Elam.) Different curves will result from different rates of deformation making the "equicohesive temperature" actually a range of temperatures when this factor is considered.

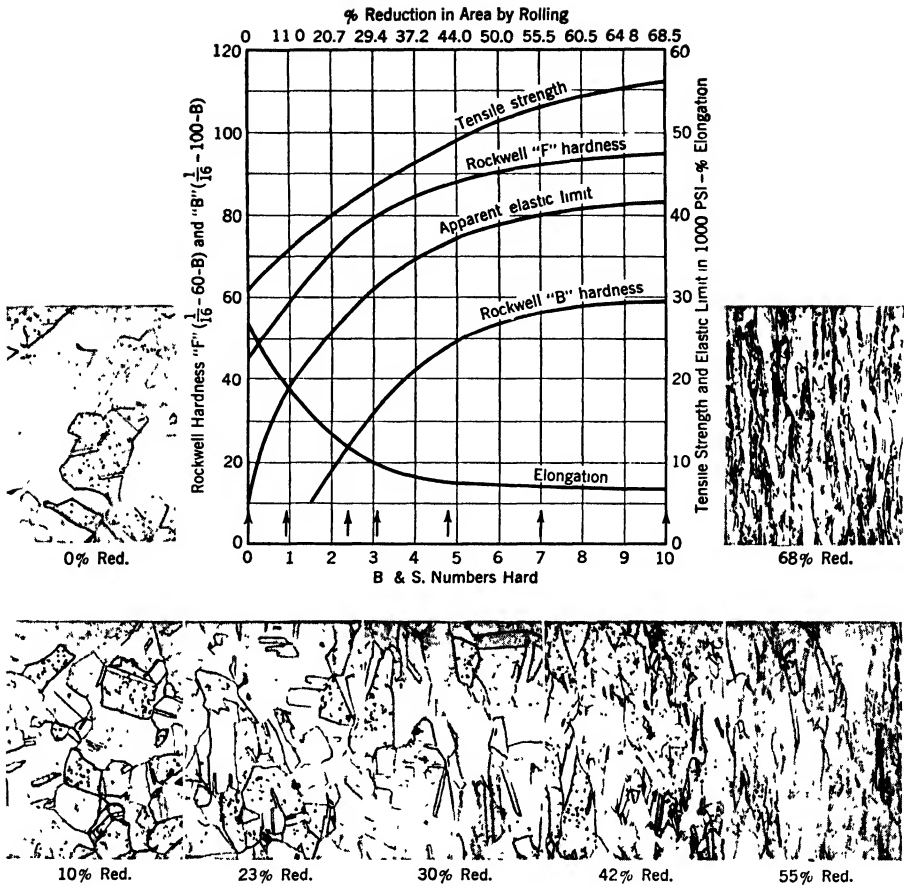


FIGURE 60. Diagrammatic representation of the changes in microstructure and properties resulting from cold-working oxygen-free copper. (Data from *Copper and Copper Alloys*, by R. A. Wilkins and E. S. Bunn: McGraw-Hill Book Company, Inc., New York; photomicrographs by L. Litchfield.)

less of the actual temperature involved. Cold-work, proceeding by a complex process of slip, either alone or accompanied by twinning, within the grains and movement between the grains, always results in a distorted and disrupted crystalline structure, a marked increase in both hardness and strength, and a decrease in workability. These changes in properties are illustrated diagrammatically in Fig. 60. For most metals the amount of energy that must be expended to produce a given reduction or change in section by cold-work is comparatively great, and increases constantly with the amount of deformation. On the other hand, accurate dimensions and an improved surface appearance are produced by cold-work. Under proper conditions, even mirrorlike finishes are possible.

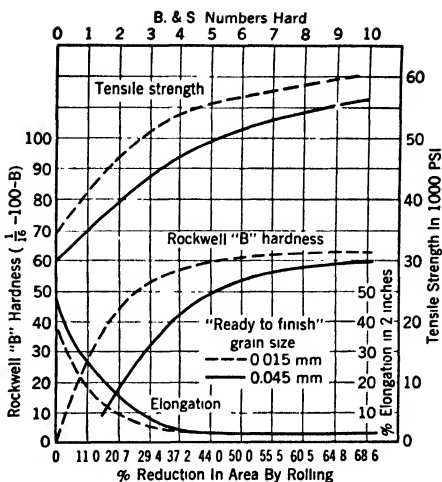
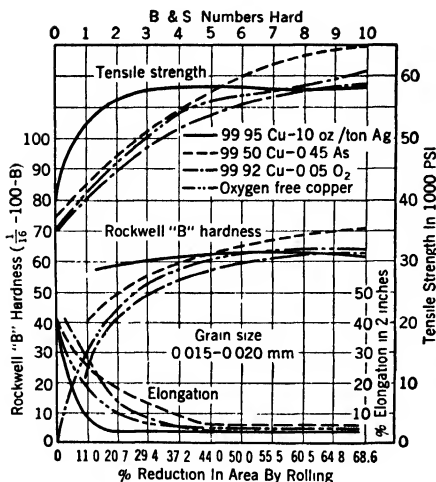


FIGURE 61. (Left) Effect of small additions of various elements on the work-hardening characteristics of copper. (From *Copper and Copper Alloys*, by R. A. Wilkins and E. S. Bunn: McGraw-Hill Book Company, Inc., New York.)

FIGURE 62. (Right) Comparative effects of grain size on the work-hardening characteristics of oxygen-free copper. (From *Copper and Copper Alloys*, by R. A. Wilkins and E. S. Bunn: McGraw-Hill Book Company, Inc., New York.)

Both impurities and alloying elements tend, in general, to cause the metal to work-harden more rapidly and to a greater extent than it would if they were absent. This is shown quite well by some of the commercial grades of copper (Fig. 61).

EFFECTS OF GRAIN SIZE ON COLD-WORKING

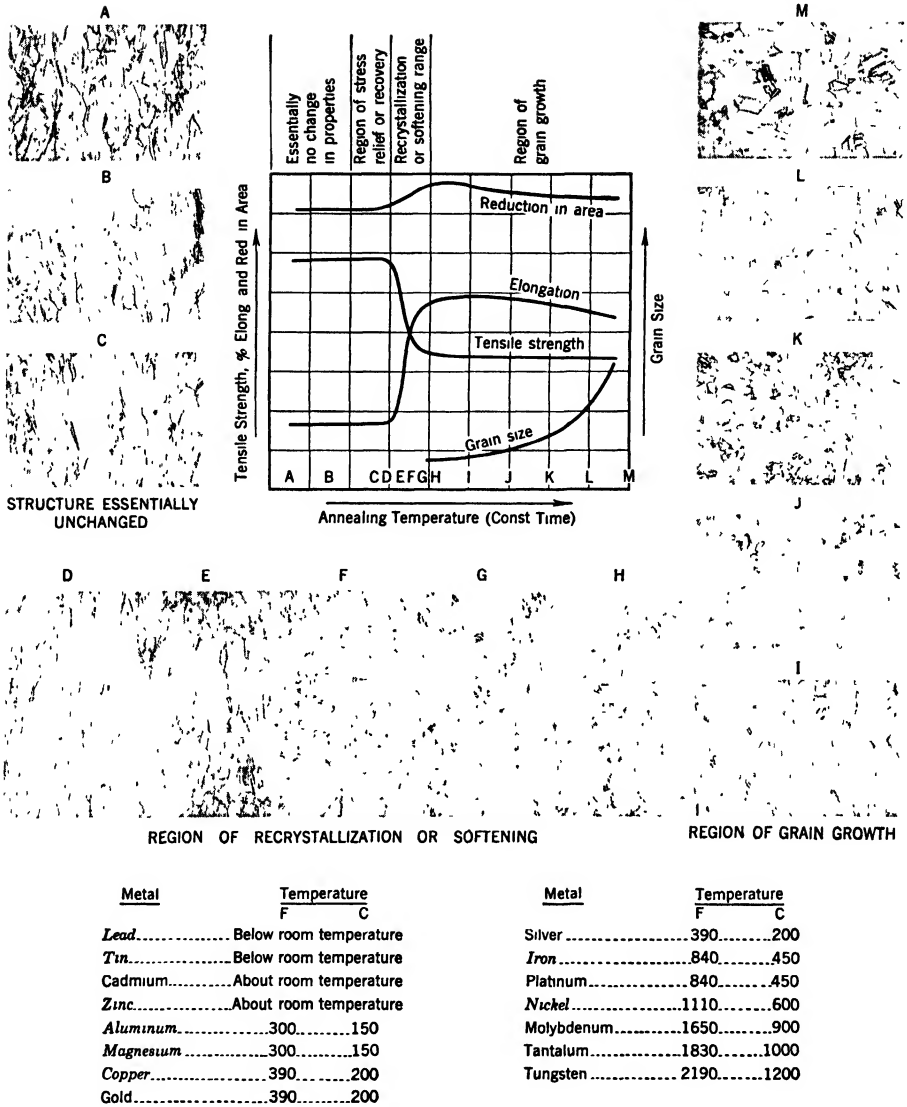
In general, the finer the grain size of the material, the greater will be the increase in strength and hardness produced by cold-work (Fig. 62), and the greater will be the energy required to produce a given deformation. Usually, a coarse grain tends to give a poor surface appearance because of the movements between the grains pointed out previously. It should be clear, therefore, that grain size control will influence not only the characteristics of the metal after working, but also its general appearance and the energy that must be expended in working it.

EFFECT OF HEATING AFTER COLD-WORKING

If a cold-worked material is heated to a series of constantly increasing temperatures and then cooled to room temperature and tested, data will be secured similar to those plotted in Figure 63.<sup>8</sup> For simplicity, the time

<sup>8</sup> See, for example, R. F. Mehl, "Recrystallization," *Metals Handbook*, A.S.M., 1939, 207-213.





APPROXIMATE LOWEST RECRYSTALLIZATION TEMPERATURES OF VARIOUS METALS<sup>1</sup>

FIGURE 63. Diagrammatic representation of the changes in microstructure and properties of a cold-worked metal resulting from heating to elevated temperatures for a constant time. (Photomicrographs courtesy R. H. Harrington.)

<sup>1</sup> (After *Science of Metals*, by Z. Jeffries and R. S. Archer: McGraw-Hill Book Co., Inc., New York, 1924.)

should be kept constant. It will be found that heating below a certain temperature range produces essentially no change in properties. The strength and hardness both remain high, the ductility low, and high inter-

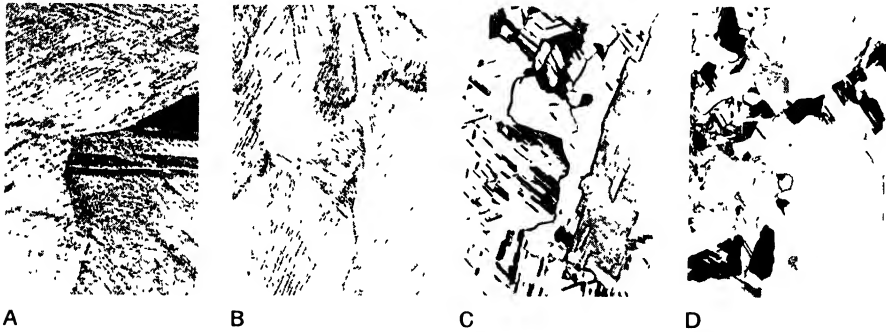
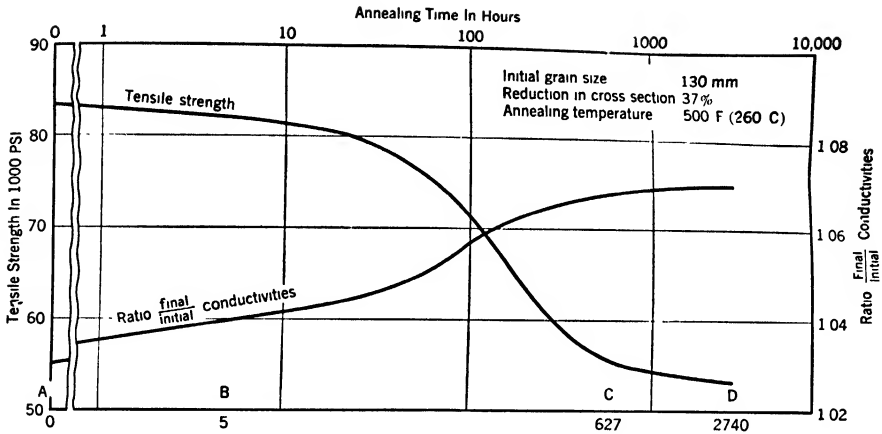


FIGURE 64. Changes in microstructure and properties at various stages of recrystallization of an alloy containing 70% Cu-30%Zn when heated for varying times at a constant temperature. Initial grain size, 0.130 mm; reduction in area by drawing, 37%; annealed at 500 F (260 C) for times shown. Etched with  $NH_4OH + H_2O_2$ . Original magnifications: A, B, C,  $\times 500$ ; D,  $\times 250$ ; reduced approximately one half in reproduction. (Courtesy Research Department, Chase Brass & Copper Co.)

nal stresses produced by the deformation will persist within the metal. A range of temperatures will then be encountered, called the *region of stress relief* or *recovery*, in which the internal stresses either will be decreased markedly or else be balanced and thus rendered ineffective. There will not, however, be any pronounced change in either the structure or the mechanical properties, except for, in some materials, an increase in the proportional limit or the yield strength. The strength and hardness even may increase slightly within this range. When heated to higher temperatures, however, marked changes will occur in both the structure and the mechanical properties. The metal will undergo both recrystallization and grain growth. The deformed structure will be removed completely, both the strength and

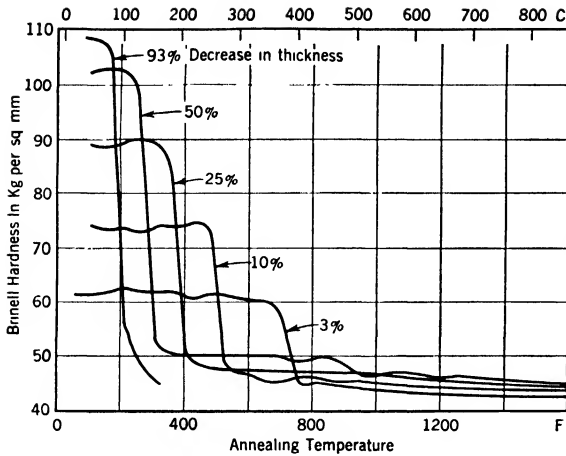


FIGURE 65. (Left) Influence of reduction in thickness on the softening temperature of cold-rolled high-purity copper. (After W. Koester.)

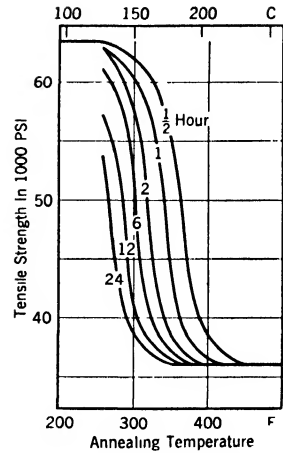


FIGURE 66. (Right) Influence of annealing time on the softening temperature of copper wire reduced 93% by cold-drawing to a diameter of 0.0105 in. (0.26 mm). (After W. E. Alkins and W. Cartwright.)

hardness will decrease markedly, and the ductility will be restored to its original high value.

### STRAIN RECRYSTALLIZATION

Within the cold-worked material there exists many small regions which may be termed strain recrystallization nuclei. These will tend to serve as centers of crystallization of a new and unstrained structure provided a sufficient intensity of energy is made available, i.e., the atomic mobility is increased sufficiently. In Fig. 64 some structural and property changes at various stages of the process of recrystallization at a constant temperature are shown. The initial deformed and strengthened structure, produced by cold-work and unaffected by heating for moderate times below the recrystallization range because of an insufficient intensity of available energy, will be removed completely and in its place will be formed an entirely new unstrained structure whose mechanical properties will be radically different from those of the cold-worked structure (cf. Fig. 63 also).

### EFFECT OF TIME, AND PERCENTAGE REDUCTION BY WORKING, UPON RECRYSTALLIZATION

✕ Recrystallization is a *rate process*, as are nearly all the other reactions in the solid state. Hence, the lower the temperature at which it occurs, or

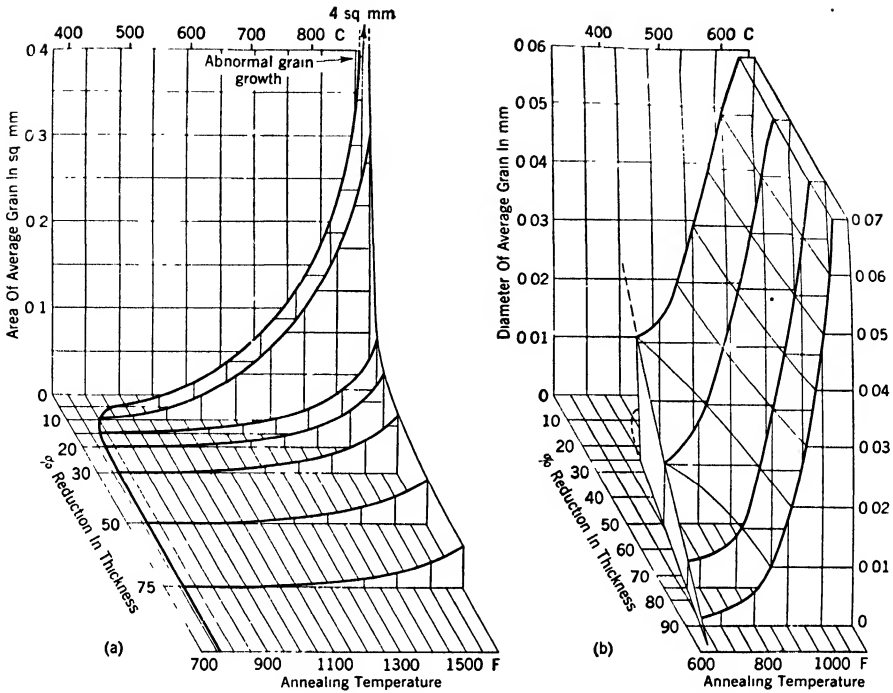


FIGURE 67. Recrystallization diagrams for (a) iron (after P. Oberhoffer and W. Oertel); (b) cartridge brass, 70% Cu-30% Zn (after R. S. French, *Metals Tech.*, A.I.M.E., Feb. 1944).

the lower the intensity of the available energy, the more slowly will it tend to take place. The exact nature of this rate function has not been established except that it is thought to be a complex one. Heavy reductions in thickness by cold-working before heat-treatment tend to increase the ease of recrystallization, possibly by increasing either the number of available nuclei or their ease of formation. Hence it may be stated that, in general, the greater the amount of previous cold-work, the lower will be the recrystallization temperature range for a constant annealing time, and the longer the annealing time the lower will be the recrystallization temperature range for a constant amount of cold-work.<sup>9</sup> These statements are illustrated for high-purity copper by the plots of Figs. 65 and 66. In Fig. 67 the combined relationship between grain size, reduction in thickness, and annealing temperature is shown for commercially pure iron and for cartridge brass.

It may be stated, also, that quite similar results can be produced either by heating for long times at temperatures slightly above the recrystalliza-

<sup>9</sup> See S. E. Maddigan and A. I. Blank, *Trans. A.I.M.E.*, 137, 1940, 170-192.

Influence Of Small Amounts Of Foreign Elements on the Recrystallization Temperature Of Copper Previously Reduced 98% by Working <sup>1</sup>

Element	Weight % added to copper	Recrystallization temperature	
		F	C
Copper (Electrolytic)	.....	390	200
Aluminum	0.12	300	150
Iron	0.21	375	190
Bismuth	0.027	390	200
Zinc	0.33	430	220
Silicon	0.06	475	245
Gold	0.20	480	250
Nickel	0.28	480	250
Arsenic	0.14	480	250
Sulfur	0.21	525	275
Antimony	0.06	535	280
Cadmium	0.19	570	300
Manganese	0.23	610	320
Phosphorus	0.36	615	325
Lead	0.15	615	325
Silver	0.24	645	340
Tin	0.24	705	375

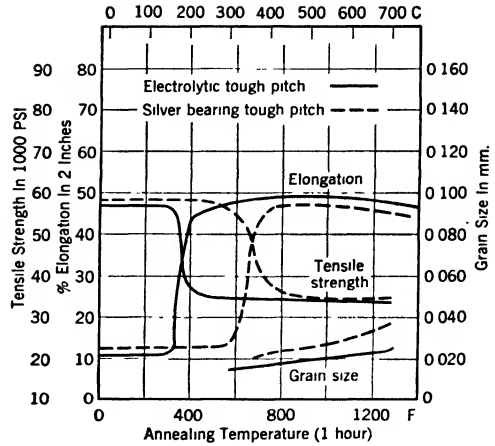


FIGURE 68. (Left) Influence of foreign elements on the recrystallization temperature of copper. (Right) Effect of silver on the annealing characteristics of copper rod. (Courtesy Bridgeport Brass Co.)

<sup>1</sup> (After H. Widmann, *Zeit. Physik*, 45, 1927, 200.)

tion range, or for short times at temperatures considerably above the recrystallization range. In the former case the material will be much more likely to be in equilibrium than in the latter case because, if equilibrium were established in both cases, the results should differ appreciably.

Usually the addition of impurities to a pure metal tends to increase its recrystallization temperature, as shown in Fig. 68 for silver and other metals in copper; and to decrease the rate at which recrystallization occurs. There are a few possible exceptions to this statement but it is generally true.

GRAIN GROWTH AFTER RECRYSTALLIZATION

Once recrystallized, grains will tend to grow in size, by absorbing both the adjacent deformed material and their recrystallized but less stable neighbors, as long as the available intensity of energy is sufficiently large. Consequently, for every temperature above the strain recrystallization range, there should be an equilibrium grain size for a given metal, which cannot be exceeded in any reasonable time. Both the magnitude and rate of attainment of this size are functions of the heat-treating temperature. In general, the higher the annealing temperature, the larger the equilibrium grain size will tend to be, and the more rapidly will it be attained.

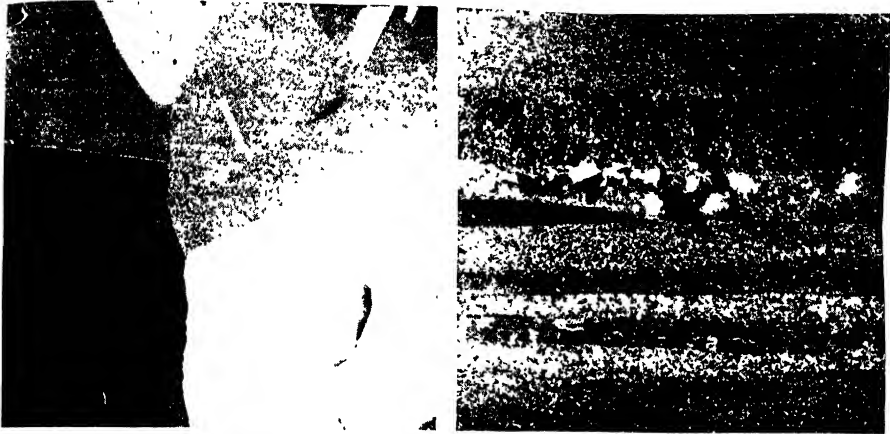


FIGURE 69. Effect of impurities on the grain size of lead. Etched with acetic acid +H<sub>2</sub>O<sub>2</sub>.  $\times 50$ .

*a.* (Left) Pure (coarse grain) 99.999+% lead, recrystallized after deformation.  
*b.* (Right) Impure (fine grain), 0.02% Ca-0.02% Mg-0.25% Sn-rem. Pb, partially recrystallized after cold-rolling 90%. The "bands" are probably remnants of the original coarse grains which were elongated during rolling. (Photomicrographs courtesy Research Department, American Smelting and Refining Company.)

Impurities tend to decrease the rate of grain growth as well as the size of the grains that will be produced in a given time at temperature. Hence, they tend to produce what is sometimes known as a *fine grain structure*. This effect is indicated in Fig. 69 for the metal lead.

#### COARSENING TEMPERATURE

The effect of impurities in producing a fine grain structure may either be temporary, or it may persist for temperatures up to the melting point. In the former case, the grains will remain fine for annealing temperatures up to a certain limit, known as the coarsening temperature. If this temperature is exceeded, the grains will become larger, just as though the impurities were not present. Increasing the annealing time also may cause the fine grains to coarsen. In some cases, indeed, they will coarsen more rapidly

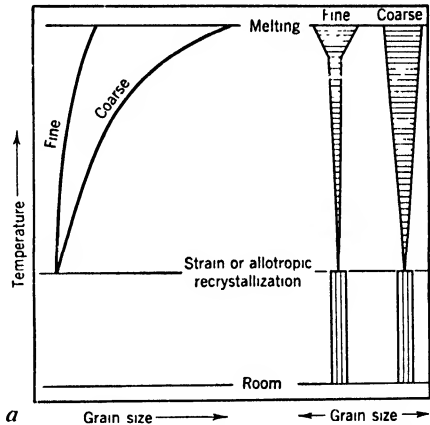
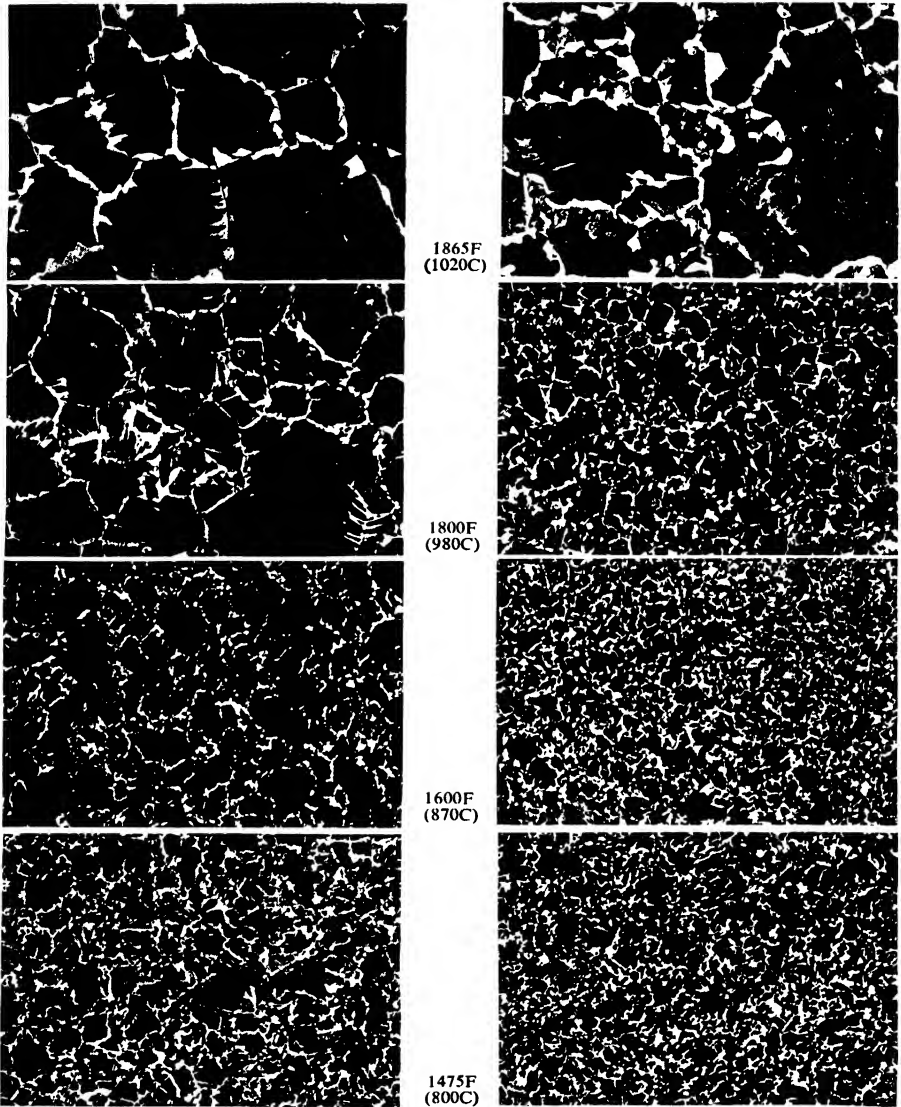


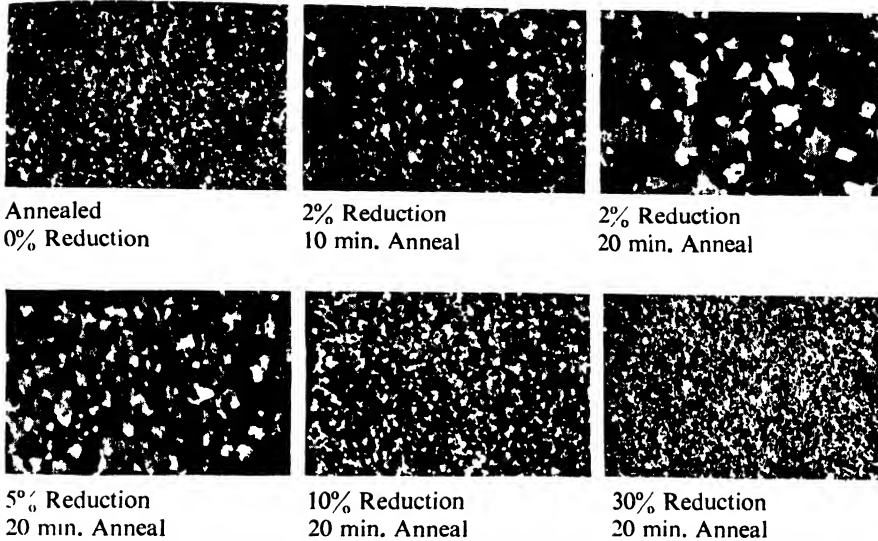
FIGURE 70. Various methods of illustrating the effects of temperature on grain size. *a.* Graphical plots in two different ways. In the left-hand example the coarsening of the fine grain material is indicated as being much less than in the right-hand example. (*b.* See p. 96.)



*b*

FIGURE 70 (continued). *b*. Composite micrographs showing the actual grain sizes of coarse- (*left*) and fine grain (*right*) steels after normalizing at the temperatures shown. Etched with 1% nital.  $\times 100$ . (Photomicrographs courtesy T. G. Digges and S. J. Rosenberg.) See also Figure 351.

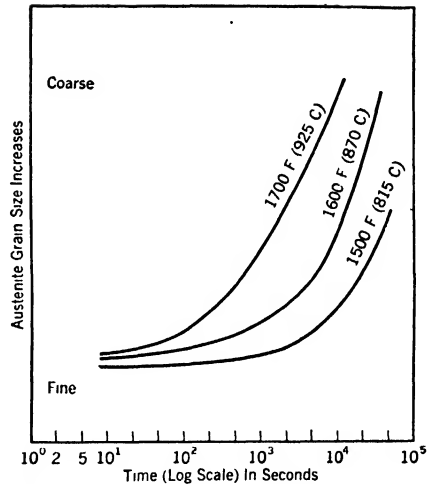
than the normal material under either change. The terms “*fine*” grain and “*coarse*” grain, therefore, refer only to the results of certain more or less definite treatments. In the so-called coarse grain materials grain growth generally proceeds in a more regular manner than in the fine grain materials. These effects are illustrated diagrammatically in Figs. 70 and 71*b*.



71a

FIGURE 71. Examples of the effects of preliminary cold-working and time of annealing on grain coarsening. *a.* The macrograin structure ( $\times 0.6$ ) of pure aluminum sheet resulting from rolling different reductions and then annealing at 950 F (510 C) for 10 or 20 min. (Macrophotographs courtesy Aluminum Company of America.) *b.* Effects of time on the coarsening of austenitic grains in an iron-carbon alloy. (From J. Johnston, *Trans. A.I.M.E.*, 150, 1942, 1-29.)

ABNORMAL GRAIN GROWTH



71b

The opposite extremes also may obtain, and the grains of an aggregate may coarsen far more than would be expected for a given annealing temperature or treatment. If the reduction by cold-work is relatively small, generally less than about 5%, few if any nuclei for recrystallization are produced, and the sole effect of the deformation seems to be a partial rupturing of the material at the grain boundaries. Consequently, when the specimen is heated to the proper temperature range, largely determined by trial and error, the existing grains will tend to grow by absorbing their less stable neighbors, but without passing through any real stage of recrystallization.



This effect is indicated in the low deformation regions of the diagram in Fig. 67a, and is illustrated for pure aluminum by means of the photomicrographs shown in Fig. 71a. It naturally leads to the formation of abnormally large grains; and, by heating to the proper temperature range, comparatively large specimens of some metals, notably aluminum, have been converted into single crystals<sup>10</sup> by this method.

Similar effects also have been found in copper after very heavy reductions in rolling and high temperature anneals,<sup>11</sup> so the particular metal involved must have some influence.

In some cases, furnace atmospheric conditions, i.e., reducing, oxidizing, or neutral, have been known to exert a pronounced effect upon grain growth<sup>12</sup> because of their influence on the factors which normally inhibit it. In view of the statements made previously regarding the effect of large grains in producing an orange-peel surface, it readily can be seen that the conditions tending to produce such effects must be known and kept under careful control if consistent results are to be secured.

#### EFFECT OF RATE OF COOLING FOLLOWING STRAIN RECRYSTALLIZATION UPON GRAIN SIZE

After strain recrystallization of a material deformed a definite amount, the grain size is determined both by the temperature to which the strained material is heated, and the time it is held at that temperature. Even if equilibrium has not been attained at the actual temperature of heating, as soon as cooling begins a temperature will be reached for which the grain size is as large as it can grow in a given time with the intensity of energy available; and for which it will be, therefore, in essential equilibrium. These grains so produced are rigid structures, and the only way their size can be decreased is by working, and subsequent recrystallization to a smaller size. Hence, cooling alone involves simply decreasing the intensity of energy to such a low level that no further changes can occur in the time available. As a result, the rate of cooling will have no effect upon the grain size and no effect upon the properties unless the thermal strains produced by rapid cooling are sufficiently large to produce some deformation or high internal stresses.

After ordinary strain recrystallization, therefore, it should make little

<sup>10</sup> See, C. F. Elam, *loc. cit.*

<sup>11</sup> See M. Cook and C. Macquarie, *Trans. A.I.M.E.*, **133**, 1939, 142-160.

<sup>12</sup> See, for example, A. Phillips and M. J. Weldon, *Trans. A.S.M.*, **23**, 1935, 886-905, and discussion.

difference upon either the mechanical properties or the structure whether the metal is cooled slowly or quenched.

### ALLOTROPY

The atoms of some chemical elements, both metallic and nonmetallic, will crystallize on different space lattices under different conditions of temperature or pressure. Such materials are said to be allotropic. Practically, this term is used interchangeably with the term *polymorphic*.

### ALLOTROPIC METALS

The principal allotropic metals are: *chromium, cobalt, iron, manganese, nickel, tin, and tungsten*. Of these, the most important, from both a practical and a scientific viewpoint, is undoubtedly the metal iron. All of the major changes which take place in steel, and the other iron alloys, are related either directly or indirectly to the allotropic changes occurring in iron. Without these changes, iron and its alloys would not be nearly so important as they are today since it would not be possible to modify their properties so drastically by heat-treatment.

### THE METAL IRON<sup>13</sup>

The allotropic changes occurring in pure iron are illustrated in Fig. 72a. Below its melting point, at about 2800 F (1535 C), iron crystallizes in a body-centered cubic arrangement which is termed *delta* ( $\delta$ ) iron. This form persists, perfectly stable, until a temperature of 2570 F (1410 C) is reached. Here, there is a spontaneous rearrangement of the atoms into a face-centered cubic form which is known as *gamma* ( $\gamma$ ) iron. No further change occurs until 1670 F (910 C) is reached. The most important change takes place at this temperature, the change from the face-centered cubic gamma form back to the body-centered cubic arrangement, now, however, termed *alpha* ( $\alpha$ ) iron. In so far as is known today, no atomic rearrangement occurs at any temperature below this in iron of any purity that has been studied.

### THE CURIE POINT

Although the change from gamma to alpha is the last change known involving an atomic rearrangement, there is another change, at about

<sup>13</sup> See *The Metal Iron*, by H. E. Cleaves and J. G. Thompson: McGraw-Hill Book Company, Inc., New York, 1935.

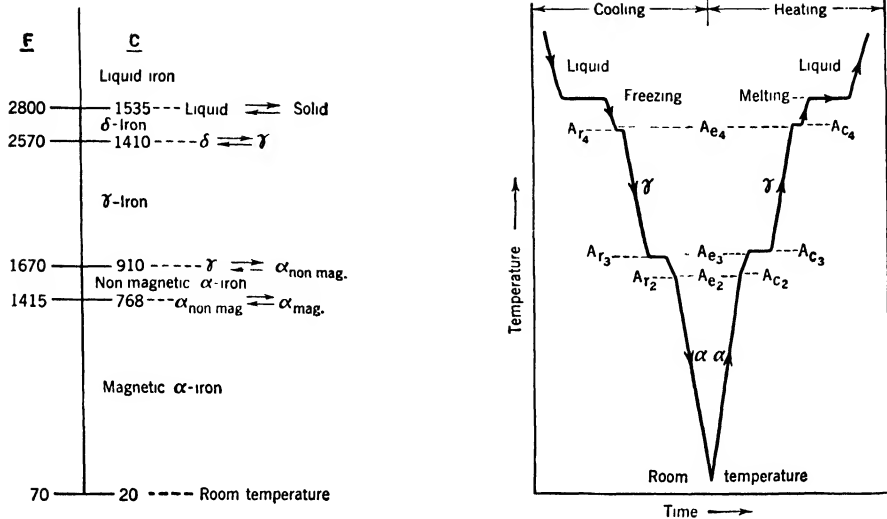


FIGURE 72a. (Left) Schematic representation of allotropic transformations in iron. b. (Right) Schematic cooling and heating curves for iron, showing nomenclature customarily employed.

1415 F (768 C), known as the *Curie point*, in which alpha iron becomes ferromagnetic. This probably is caused by some change in the atoms themselves, such as an electron rearrangement or shift, although the exact reason for it has not been established.

#### ENERGY CHANGES CONNECTED WITH ALLOTROPY

Just as there is an evolution of a latent heat of fusion when liquid iron solidifies, there is an evolution of heat when each of the allotropic changes occurs. In fact, the energy spontaneously evolved at the change from the gamma to the alpha form on cooling is sufficiently great to cause the temperature of the metal to increase appreciably, a phenomenon known as *recalescence*.

With careful experimental procedure, these changes in heat content would be indicated on a cooling or heating curve, either as a constant temperature halt or arrest, or as a change in slope of the curve. Since these arrests were determined first by the French scientist, LeChatelier, his original terminology always has been used in designating them, as indicated in Fig. 72b. The occurrence of an arrest is indicated by the letter *A* (from the French *arrêt*). If the change occurs on heating, the subscript *c* is used (from the French *chauffage*), whereas if it occurs on cooling, the

subscript  $r$  is employed (from the French *refroidissement*). These changes then are designated individually by number, the highest temperature one (delta  $\rightleftharpoons$  gamma) being  $A_{c_4}$  or  $A_{r_4}$  as the case might be, the next (gamma  $\rightleftharpoons$  alpha)  $A_{c_3}$  or  $A_{r_3}$ , and the magnetic change  $A_{c_2}$  or  $A_{r_2}$ . In a general reference to one of these transformations, the letter subscript is usually eliminated, and it is referred to simply as  $A_4$ ,  $A_3$ ,  $A_2$ , etc. The  $A_1$  change occurs only in the presence of carbon, and hence is not found in pure iron. The exact nature of the  $A_0$  change, which will be mentioned later, is still obscure. The letter  $e$  which sometimes is used also as a subscript in referring to these changes, e. g.,  $A_{e_3}$ , customarily indicates the equilibrium temperature at which the transformation occurs, viz., the transformation temperature approached as the rates of heating or cooling approach zero.

#### ALLOTROPIC RECRYSTALLIZATION

In addition to the strain recrystallization which pure iron will undergo after cold-working, when heated to about 1200 F (650 C) or higher, another type of recrystallization is possible, which under the proper conditions occurs spontaneously and without any necessity for strain or other complicating conditions. This is the recrystallization accompanying the allotropic change occurring at  $A_3$ . When pure iron is heated through this temperature, regardless of its previous physical condition, it will recrystallize spontaneously because of the allotropic rearrangement of the atoms into the face-centered cubic gamma form. The grain size of the resulting gamma iron, Fig. 73, will depend, exactly as in the case of strain recrystallization, upon the purity, and upon the temperature and the time, viz., the intensity of energy required to be effective in a given time. Thus, by supplying only a relatively low intensity of energy, as by heating just above  $A_3$ , a small gamma iron grain size will result. On the other hand, a large gamma iron grain size can be produced by heating just below  $A_4$ , and thus supplying a comparatively high intensity of energy. As before, also, the lower the temperature the longer will be the time required to attain a grain size that is in essential equilibrium, although in these temperature ranges none of the times is very great.

A similar recrystallization would take place on heating through  $A_4$ , but this is relatively unimportant commercially.

The ferrite grain size, or the grain size of the room-temperature stable alpha iron, is the one most frequently referred to in commercially pure irons, whereas the grain size of the gamma iron is the important one in most commercial iron alloys, including the steels.

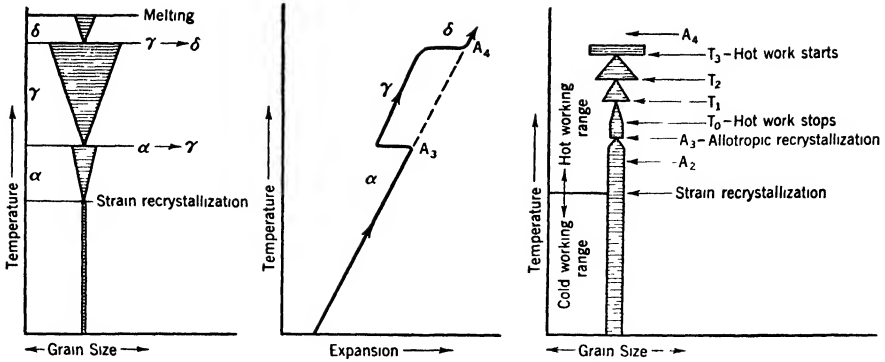


FIGURE 73. (Left) Schematic representation of strain recrystallization and allotropic recrystallizations when cold-worked iron is heated. See also Fig. 351.

FIGURE 74. (Center) Schematic representation of the thermal expansion and contraction of iron during heating.

FIGURE 75. (Right) Schematic representation of the change in grain size of pure iron during hot-rolling to a temperature just above  $A_3$ .

#### PROPERTY CHANGES RESULTING FROM ALLOTROPIC RECRYSTALLIZATION IN IRON

The allotropic changes in commercially pure iron (ferrite) are important because they permit the production of either a relatively weak coarse grain or a stronger fine grain alpha ferrite structure at will, merely by varying the heat treatment used. All of the mechanical properties of the iron will depend, to some extent, on its grain size. In addition, there is a pronounced contraction in volume at  $A_{c_3}$  and a comparable expansion at  $A_{c_4}$ , because of the fact that the face-centered cubic arrangement is more closely packed than the body-centered cubic one. These volume changes are reversed on cooling. This is illustrated in Fig. 74, and is of some importance commercially.

#### EFFECT OF RATE OF COOLING AFTER ALLOTROPIC RECRYSTALLIZATION

In the case of the allotropic recrystallization of iron, in direct contrast with that of strain recrystallization, the rate of cooling will affect the final grain size of the alpha ferrite markedly, even though it will have no influence upon the grain size of the gamma iron produced by heating. In this instance, nuclei for starting the recrystallization are produced spontaneously by the allotropic transformation, which takes place on cooling as well as on heating. Since nuclei are produced on cooling, the effects

resulting are comparable to those already discussed under the solidification of a liquid metal. This is true even though, in this instance, the changes take place entirely within the solid state instead of in the transition between the liquid and solid states.

When iron is cooled slowly through  $A_3$ , therefore, comparatively few alpha nuclei are formed. In addition, the decrease in the intensity of energy is so gradual, and the rate of growth of the new grains is so rapid, that a coarse alpha ferrite grain size almost invariably results unless impurities exist to modify one or more of the controlling factors.

On the other hand, as the rate of cooling is increased, the number of available alpha nuclei tends to increase, the decrease in the intensity of energy becomes more marked, and the time available for grain growth decreases. All of these factors tend to combine to give a fine alpha grain size.

In some metals and alloys, since a certain amount of energy in addition to a tendency to transform also is required to start the change, the allotropic transformation may be suppressed entirely by cooling rapidly enough, and the higher temperature form will be retained at room temperature even though it will be unstable. However, in pure iron this cannot be done, and, regardless of the rapidity of cooling, the allotropic change will take place. Only by slowing down the transformation by alloying can it be suppressed, and the gamma form retained at room temperature.

#### RECRYSTALLIZATION OF CAST STRUCTURES

Since castings, as a rule, solidify comparatively slowly from the liquid state they normally will have a coarse grained structure, as already pointed out. Comparatively poor mechanical properties generally accompany such structures, and hence it would be desirable to refine them by recrystallization if it could be done. Unfortunately, however, this is only possible when the metal or alloy undergoes an allotropic transformation, and hence, can recrystallize spontaneously. Practically, this is only true of iron alloys. In all other metals and alloys some cold-working is required before strain recrystallization can take place. Clearly, such cold-working of a casting would be difficult if not impossible, because not only are castings poured directly to their final shape, but also they are frequently of compositions which are not amenable to mechanical working.

It is this fact, more than any other, which restricts the use of nonferrous castings in many applications. With these materials the initial cast structure is the final structure, and no further refinement of it is possible, even though the properties of some alloys can be improved somewhat by proper

heat-treatment. With ferrous castings, on the other hand, a grain refinement results from every heating or cooling through an allotropic transformation, and, hence, appreciable improvement of both structure and properties can be secured by simple heat-treatments, as will be discussed in more detail in later sections.

### HOT-WORK ✓

When a metal is worked above its strain recrystallization temperature, it will tend to recrystallize spontaneously as soon as it is deformed mechanically. Hence, it cannot work-harden because any effects of stress will be removed as soon as they are produced. Work of this nature is known as hot-work, and it must be emphasized again that reference is to a temperature which is characteristic for the metal concerned, and that, by itself, has no significance. For example, lead or zinc would be hot-worked at 68 F (20 C) or less, whereas iron and nickel could be cold-worked at 1000 F (540 C) or more.

Hot-work has other advantages. It requires a much smaller amount of energy than cold-work because, with the exception of tungsten, metal is always more plastic in the hot-working than in the cold-working range. In addition, the metal can be deformed hot to a greater extent, and in larger steps than in cold-work because it remains soft throughout, and does not work-harden.

Hot-work also has certain disadvantages, however. The comparatively high temperatures at which it occurs in most metals usually make accurate dimensions difficult, if not impossible, to attain; surface oxidation is apt to be heavy; and the metal cannot be hardened or strengthened by the working.

Hot-working is used more frequently for the early and intermediate stages of working than for the final ones, although the finish, the accuracy of dimensions, and the properties desired are the real determining factors on this point.

### EFFECT OF HOT-WORK ON GRAIN SIZE

In general, hot-working tends to reduce the size of the grains that are stable at the working temperature. However, this is only true because cooling nearly always occurs simultaneously with hot-working, especially as the thickness of the piece is decreased, and its other dimensions are increased.

If a piece of metal (Fig. 75) is worked at a temperature,  $T_3$ , at which it

has a relatively coarse grain size, strain recrystallization will result. The grains in the new structure will tend to grow immediately toward their equilibrium size. However, this equilibrium size will be smaller than that existing before deformation, because the metal will have cooled to a lower temperature,  $T_2$ . Further working and cooling will produce still smaller grains; and, thus, it can be seen readily that the limiting size will be reached at the strain recrystallization range itself. If working is stopped just above this range, the resulting unstrained grains will have the smallest possible size. If, on the other hand, it is continued below it, then the existing grains will be strained and cold-worked. In some instances, an increase in the strain recrystallization temperature resulting from alloying makes the temperature at which an allotropic change occurs, rather than that of the strain recrystallization range, the lowest at which it is desirable to hot-work. The principle will be the same in either case.

*For Further Study Refer to*

1. *The Principles of Physical Metallurgy*, 2d ed., by G. E. Doan and E. H. Mahla: McGraw-Hill Book Company, Inc., New York, 1941.
2. *Introduction to Physical Metallurgy*, by L. R. Van Wert: McGraw-Hill Book Company, Inc., New York, 1936.
3. *Metals Handbook*: American Society for Metals, Cleveland, Ohio, 1939 (usually published triennially). A new edition will appear in 1948.
4. *Principles of Metallography*, 4th ed., by R. S. Williams and V. O. Homberg: McGraw-Hill Book Company, Inc., New York, 1939.
5. *Metals*, by Sir Harold Carpenter and J. M. Robertson: Oxford University Press, London and New York, 1939.
6. *Metallography*, 4th ed., by C. H. Desch: Longmans, Green and Company, New York, 1937.
7. *The Metallography and Heat Treatment of Iron and Steel*, 4th ed., by A. Sauveur: University Press, Cambridge, Mass., 1935.
8. *Practical Metallurgy*, by G. Sachs and K. R. Van Horn: American Society for Metals, Cleveland, Ohio, 1940.



### III Metallurgical Methods

#### THE NATURAL OCCURRENCE OF METALS

THE EARTH'S CRUST IS A RELATIVELY THIN LAYER UPON WHICH we live, and from which we extract the metals that we use. The average percentage distribution of the more plentiful of them in this crust is shown in Table IX, and, geographically, they are quite widespread.

TABLE IX AVERAGE PERCENTAGE DISTRIBUTION OF THE COMMON ELEMENTS IN THE EARTH'S CRUST

Si	27.61	H <sub>2</sub>	0.14
Al	8.07	P	0.12
Fe	5.06	C	0.09
Ca	3.64	Mn	0.09
Na	2.75	S	0.06
K	2.58	Ba	0.03
Mg	2.07	Sr	0.02
Ti	0.62		

It is noteworthy that only three of the basic engineering metals, viz., *aluminum*, *iron*, and *magnesium*, appear on this list; and that none of the others constitutes more than 0.02% of the earth's crust. This, of course, is an average figure and does not preclude their occurrence in isolated ore bodies, which is the state of affairs actually existing.

These elements occur more often in physical and chemical combination with other elements than in the pure state; and such naturally occurring chemical elements or compounds are known as *minerals*. The metals in them first must be extracted and purified before they can be of value in engineering.

#### ORES

Although, as a rule, minerals are distributed over the surface of the earth in a fairly uniform manner, occasionally certain of them, either alone

or in combination with other minerals, are found deposited in sufficient quantity to permit the profitable extraction, on a large scale for commercial use, of one or more of the metals present. Such deposits then are known as ores,<sup>1</sup> and are so considered as long as a margin of profit can be maintained in the extraction of the metallic values from them. The worthless minerals in an ore body, usually discarded, are known as the *gangue*, although the term *tailings* is applied to waste products of a process of concentration.

The necessity for maintaining a margin of profit in the development of any ore body cannot be emphasized too greatly. Frequently, it happens that, because of improvements in older methods of extraction or the development of new methods, it becomes profitable to work over dump heaps of discarded gangue or tailings, and to extract from them even more of their metallic values. Cases are known in which these refuse piles have yielded values even after three or four reworkings. Frequently, therefore, the tailings of one generation, in certain localities, become the ore supplies of the next, simply because they are richer than the natural deposits which are left in that vicinity or because new methods allow their working at a lower cost than originally, and because the demand for the metals present is sufficient to enable them to be worked at a profit.

Likewise, an increase in the market price of a given metal can well determine the status of a certain mineral deposit. For every ore body there is a definite production cost, dependent upon a large number of factors. To meet this, the value of the metal produced must exceed a certain figure. If it does not, then the deposit ceases to be an ore, and is just a mineral body having only potential value. The real value of any ore body, therefore, depends not only upon its metal content, but also upon its location, and its proximity to other materials necessary for the economical extraction of its metal content. Transportation facilities are also significant because, obviously, no metal is of any commercial importance until it can be gotten to a market where it can be disposed of and utilized.

#### IMPURITIES IN ORES AND THEIR CONTROL

Since ore bodies are usually mixtures of minerals, they are sources of impurities as well as of the metal desired. This, too, will determine their utility and development. As has been pointed out already, any impurity which is less active chemically than the desired metal generally will be reduced with it; and, depending on the composition of the ore and the nature of the extraction process, even some of the more active elements may find their way into the metal in small amounts if they are present in suffi-

<sup>1</sup>For a further discussion see *Ore Deposits of the Western States*: A.I.M.E., New York, 1933.

cient quantity, even though most of them will tend to oxidize, and, in this form, to combine with the gangue to form a slag. Hence, some preliminary purification or conditioning of the ore by either chemical or physical means is frequently desirable if it can be done economically. Such processes fall under the general classification of *ore dressing*. Ore-dressing processes have the added advantages that they decrease both the useless weight that must be handled and shipped and the amount of inert material that is of no value and serves only to decrease the efficiency of the later metallurgical reduction.

#### BENEFICIATION AND CONCENTRATION

Methods of ore dressing in which the worthless portions of the ore are eliminated before the metallic extraction begins are known as *beneficiation* or *concentration*.<sup>2</sup> Their purpose is to increase the effective metallic content of the ore, either by removing the worthless materials or by removing the specific minerals which are to be reduced. In many instances, the saving in transportation charges alone resulting from the removing of worthless portions of the ore more than compensates for the increased cost of the beneficiated product.

Under existing conditions, about one third of the iron ores mined in this country are beneficiated, and the percentage is increasing. Ores of the other common metals usually are concentrated by at least one of the many methods available.

Numerous methods for dressing ores may be used depending on the specific material being treated. These may be chemical in nature, such as *roasting*, i.e., heating in air or other atmospheres to change the form of the ore as well as to remove its impurities, or *leaching*, i.e., a chemical solution of either the desirable or undesirable minerals; or they may be physical, i.e., methods dependent on differences in physical properties, such as *gravity concentration* to separate the heavy from the light minerals, *magnetic concentration*, or *flotation*.

#### FLOTATION

One of the most effective concentrating methods, flotation,<sup>3</sup> takes advantage of the surface tension of foams, and the differential wetting of specific minerals by certain oils. If air is introduced into a properly prepared suspension or pulp of finely divided ore and water to which the proper wetting agent has been added, the froth formed will wet certain of the minerals and

<sup>2</sup> See *Textbook of Ore Dressing*, by R. H. Richards and C. E. Locke: McGraw-Hill Book Company, Inc., New York, 1940.

<sup>3</sup> See, also, *Flotation*, by A. M. Gaudin: McGraw-Hill Book Company, Inc., New York, 1932.

carry them to the surface, even though they may be heavier than water. If the particle is wet by the water instead of the foam, it will sink to the bottom and remain there. The mineralized froth can be removed by mechanical means. By this method, clean separations can be made economically with little labor or equipment. Either the desired mineral or the impurity can be carried off in the foam, depending on which is more economically removed, and the process can be carried out as either a rough or a refined separation of several minerals.

The tremendous development of flotation methods and reagents in recent years has permitted not only an expansion of facilities in many plants, but also the attainment of a greater degree of purification and the efficient utilization of many ores and tailings that were virtually worthless with the processes available previously.

#### METALLURGICAL PROCESSES

In general, all processes for the extraction of metals from their ores, and their ultimate purification, are chemical in nature. Since the combined state is the most common one, the first stage is generally one of reduction, using carbon as the usual reducing agent because of its low cost and abundance. However, in such a reduction some impurities also may be reduced, thus necessitating a subsequent purification or *refining* stage to produce commercially useful metal. Refining is generally an oxidizing process, customarily using oxygen as the oxidizing agent to remove the impurities. The chemical activities of both the desired metal and the impurities, as well as the conditions under which the process is carried out, are all, of course, of importance in determining the efficiency with which it can be operated.

Metallurgical processes generally may be classified into the three groups: *pyrometallurgical*, *hydrometallurgical*, and *electrometallurgical*, depending on whether the process takes place at high temperatures, by wet methods, or by the aid of electricity. Because of the importance of ferrous metallurgy and its products to the engineer, major emphasis here will be directed toward the methods of pyrometallurgy.

The first, or reducing, stage of a pyrometallurgical process generally is referred to as *smelting*, and may be described most simply as melting accompanied by a chemical change.

#### SLAGS

The chemistry of pyrometallurgy differs from ordinary chemistry only in the terminology used, and in the absence of water as a necessary agent.

As before, oxides of metal are generally *basic oxides*, whereas those of the nonmetals and metalloids are *acid oxides*. A few exceptions to these statements are found, however. For example,  $\text{Al}_2\text{O}_3$ , which is normally basic, acts sometimes as an acid oxide, just as its counterpart  $\text{Al}(\text{OH})_3$  sometimes acts like an acid. The two types of oxides will react and combine to form a slag, the chemical composition of which determines its melting point, fluidity, nature, and its ability to combine with and retain certain impurities. A slag, therefore, is essentially a combination and mixture of metallic and nonmetallic oxides. It is one of the most important factors in the removal of impurities by metallurgical methods, as it serves not only as a means of retaining the oxidized impurities but also, frequently, as a source of the active oxidizing agent. Furthermore, many basic slags, after they have been discarded metallurgically, are excellent fertilizers.

#### FLUXES

Any portions of the gangue in an ore, which are not chemically reduced in the process, will form a slag. However, this slag will not, as a rule, have the most desirable characteristics. Its melting point and fluidity, in particular, seldom will be exactly what is needed for its most efficient use in the process in which it is formed. For this reason, other oxides usually are added intentionally to combine with the oxidized impurities and form a slag, to control the melting point of the slag, and to control its fluidity. Because of this latter point, such oxides usually are termed fluxes. Depending upon the nature of the gangue material, these fluxes may be either acid or basic in nature, an acid gangue generally requiring a basic flux and vice versa. Depending upon the nature of the ratio between the gangue and flux, therefore, a slag may contain either an excess of the acid constituent and be an acid slag, or an excess of the basic constituent and be a basic slag. It will, however, always contain both acid and basic oxides, the type which determines the nature of the slag merely being in slight excess.

The fluxes most commonly used today are limestone ( $\text{CaCO}_3$ ), silica ( $\text{SiO}_2$ ), and certain of the fluorides.

#### REFRACTORIES

Oxides which resist the effects of high temperatures are said to be refractory. However, in order to meet the majority of the commercial requirements for this type of material, a refractory must resist as completely, and over as wide a range of temperatures as possible: (a) fusing or softening at any temperature at which it would be operated; (b) crumbling, cracking,

or spalling; (c) contraction or expansion; (d) heat flow; (e) penetration of high-temperature gases and liquids; (f) mechanical abrasion; (g) chemical reaction with the substances in contact with it. Refractories may be either acid, basic, or neutral in nature. As a rule, when they are used in contact with slags, as in a furnace lining, they should be of the same general class as the slags with which they are in contact. An acid slag in contact with a basic lining, or vice versa, naturally would corrode the lining. However, in basic-lined steel furnaces, for example, acid (silica) roofs commonly are used in conjunction with basic bottoms with a layer of a neutral refractory separating the two to prevent their interaction.

The most common refractory oxides used metallurgically today are: *silica*, *alumina*, *chromite*, *magnesite*, and *dolomite*. Generally these are used in their naturally occurring, rather than a purified, form. The last two, of course, occur naturally as carbonates and usually are calcined to the oxide entirely or partially before using.

#### PURITY OF REFRACTORIES

Both refractories and fluxes can be secured which introduce very little impurity into the metal for the processing of which they are being used. They are chiefly of interest because of their ability, under the proper conditions, to react with certain impurities and to form, in the slag, stable compounds with them. Their use as furnace linings is vital, because without them most metallurgical processes, taking place as they do at high temperatures, would not be feasible.

#### METALLURGICAL FURNACES

Furnaces used in pyrometallurgical processes generally are heated either by fuel or by electrical energy. Numerous factors are involved in the selection of a furnace for a particular process, among which may be mentioned the economic factors arising from plant location, the thermal efficiencies, and the efficiency of impurity removal when operated under specific conditions. Each type of furnace has certain advantages and disadvantages which must be balanced for each application.

#### FUEL-FIRED FURNACES

There are three general types of fuel-fired furnaces, depending upon the contact between the metallurgical charge, which will ultimately yield the desired product; the fuel; and the products of combustion.

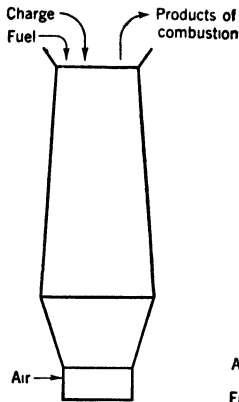


FIGURE 76. (Left) Diagrammatic example of a shaft-type fuel-fired furnace.

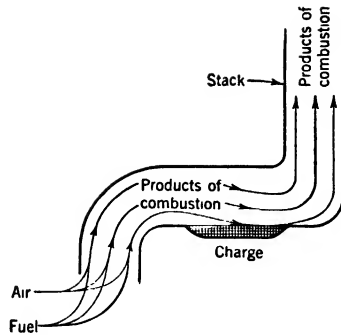


FIGURE 77. (Center) Diagrammatic example of a hearth-type fuel-fired furnace.

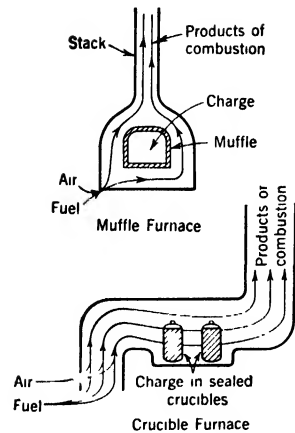


FIGURE 78. (Right) Diagrammatic examples of the muffle and crucible types of fuel-fired furnaces.

**SHAFT FURNACES** In the first type, the charge, fuel, and products of combustion, are mixed intimately, as in a shaft furnace (Fig. 76). The several types of blast furnaces used for copper, iron, lead, and tin, for example, and the cupola in which cast iron is made, are all examples of this type. Fuel generally burns when it reaches the bottom of the shaft where air is blown in to maintain combustion; and the heat and gases produced rise throughout the charge.

In these furnaces the thermal efficiency is generally high, sometimes exceeding 60%, because of the good physical contact. For the same reason, the purity is generally low. Consequently, this type seldom is used as a refining furnace, although, as a reduction furnace, its use is widespread. Because of the simple construction and high efficiency, its cost of operation is generally comparatively low. As a rule, these are all continuous furnaces.

**HEARTH FURNACES** In the second type, the fuel is burned separately, and only the charge and the products of combustion are in close contact. Air furnaces, reverberatory, and the various other types of open-hearth furnaces, similar in general shape to Fig. 77, are of this general classification. They are characterized by a shallow hearth of large area, upon which the heat can impinge either directly or by reflection from the roof. As would be anticipated, the thermal efficiency of a hearth furnace is appreciably lower than that of a shaft furnace, seldom rising above 20%, although a much greater purity can be secured because of the closer control and the absence of some of the sources of contamination. This type is used to a

limited extent as a reduction furnace, but much more widely as a refining furnace. It is used both as a continuous and as a batch-type furnace.

**MUFFLE FURNACES** In the third type, both the fuel and the products of combustion are separated from the charge. Such an arrangement is found in the muffle furnace and in the crucible furnace, for example (Fig. 78). Because of this separation, the thermal efficiency is low, nearly always less than 10%, although somewhat higher temperatures sometimes can be secured because of the relatively small volume of charge that is handled, and the lower heat losses from it. Since both the fuel and the products of combustion are eliminated as possible sources of impurity, the purity of the product is usually higher than in the other types. However, this type of furnace is generally adapted only to batch operations; and the combination of this with its small size and low efficiency tends to lead to comparatively high operating costs.

#### ELICTRIC FURNACFS

Only two general types of electric furnaces are used in pyrometallurgy: *arc* and *induction* furnaces. Some examples of both types employ resistance heating also; but because of the high temperatures required resistance heating alone is not economical as a rule.

(Electric furnaces have several advantages which serve to offset their greater operating costs. They can be run in almost any range of temperature and can maintain this temperature within fairly close limits for long periods of time. Because of the absence of both fuel and products of combustion, the dangers of contamination are decreased and almost any atmosphere or slag desired, e.g., oxidizing, reducing, or neutral can be reproduced at will. Consequently, the purity of the product can be much greater than that of the fuel-fired furnaces although, unless necessary precautions and care are taken, this need not necessarily be true. Counterbalancing these advantages there is always the higher cost of electric power, unless the unit can be located near a low-cost development or can utilize off-peak loading or some similar method for reducing these charges.)

#### ARC FURNACES

Only the *Heroult* type of arc furnace is used in the United States today to any extent, although a modification, the *Ludlum* type, is used by at least one company. The two differ principally in the arrangement of the electrodes, the Heroult having three arranged in the form of a triangle, except in the larger sizes where six electrodes are more efficient, whereas the Ludlum



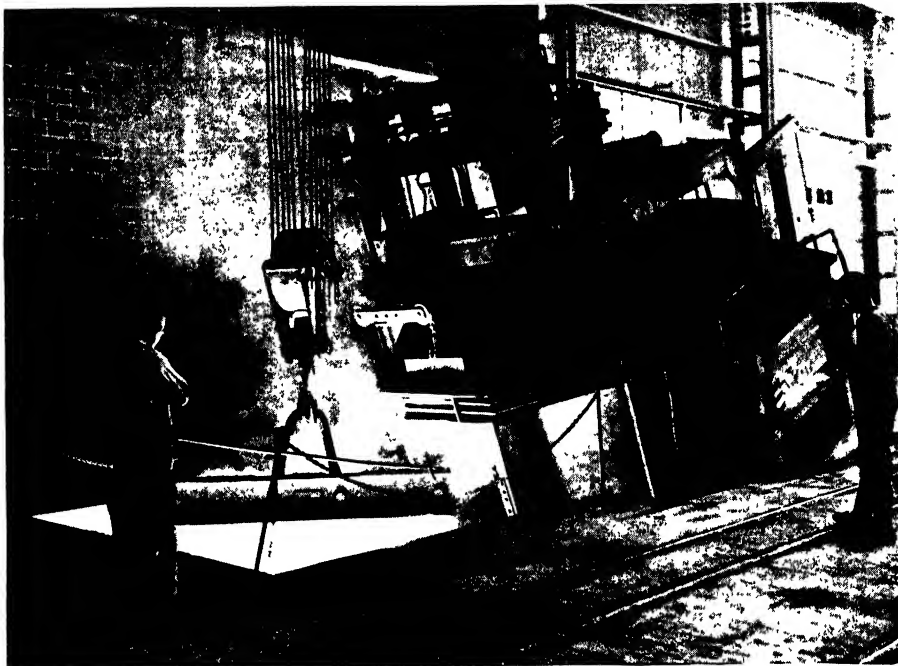


FIGURE 79. Tapping an Heroult type 20 electric-arc furnace. (Courtesy American Bridge Company.)

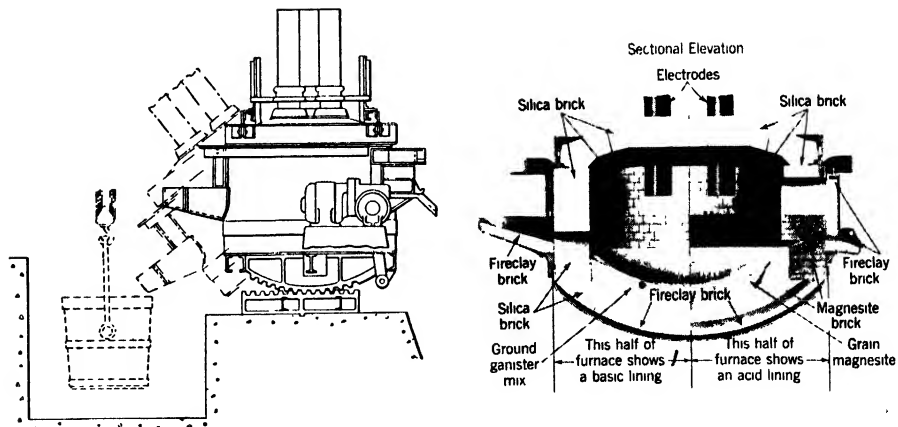


FIGURE 80. (Left) Schematic layout of a typical Heroult furnace. (Courtesy American Bridge Company.)

FIGURE 81. (Right) Cross section of a typical arc-type electric steel-melting furnace showing application of refractories. (From *Modern Refractory Practice*, courtesy Harbison-Walker Refractories Company.)

has three in a straight line. Heroult-type furnaces also are sold under the names *Lectromelt* and *Swindell-Dressler*.

The general principles of the Heroult type of furnace are illustrated in Figs. 79 and 80. The furnace is usually of the three-phase series-arc type, drawing current from a three-phase Y-delta connected transformer. All three electrodes are kept within arcing distance of the slag. The current will jump the high-resistance gap to the slag, which also has a high resistance; and then be conducted by the comparatively low-resistance metal to the region below a second electrode, where it again must pass through the high-resistance slag and jump the gap to this electrode. The power input is controlled by the distance between the electrode and the bath or slag, and in most cases this is taken care of by automatic adjustment. Practically all the heat, therefore, is formed in the arcs above the slag. The slag, by its presence, shields the metal, protecting it both from the high temperatures of the arc and from the carbon vapors thrown off from the base of the electrode. Heat distribution takes place by convection and radiation from the regions opposite the base of the arcs, and by radiation from the furnace lining. There is a slight motor or stirring effect produced in the bath by the current, and this also assists in distributing the heat.

#### ARC-FURNACE CONSTRUCTION

Arc furnaces are made in capacities varying between  $\frac{1}{2}$  and 100 tons, although an exact rating depends upon the contour, electrical capacity, etc., rather than upon metal volume alone. The range from 5 to 40 tons is most popular. These furnaces usually will tilt both forward, for pouring molten metal, and backward, for raking off slag; and may be charged either through a door or, in the larger sizes, the entire top may tilt or be removable for bucket charging. As illustrated in Fig. 81, either an acid or basic refractory may be used for lining material, depending on the specific use for which the furnace is intended.

#### ROCKING FURNACES

The rocking-type arc furnace is used to some extent in many foundries, and in some nonferrous plants. Principally, it is a melting furnace only. This furnace is a single-phase, alternating-current type, in which the heat is generated by an arc between two horizontal electrodes placed on the axis of a horizontal cylinder (Fig. 82). This is an indirect arc, i.e., neither the bath nor the slag is involved; and the heat is transmitted to the metal by reflection and radiation from the furnace lining, which may be either

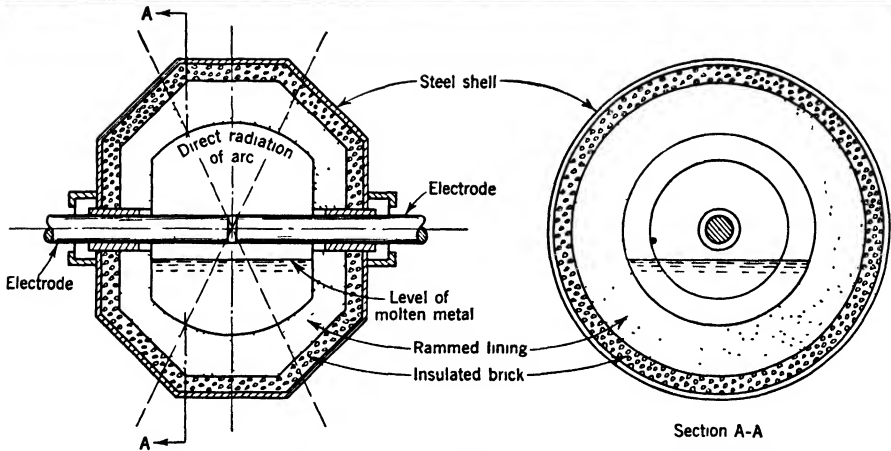
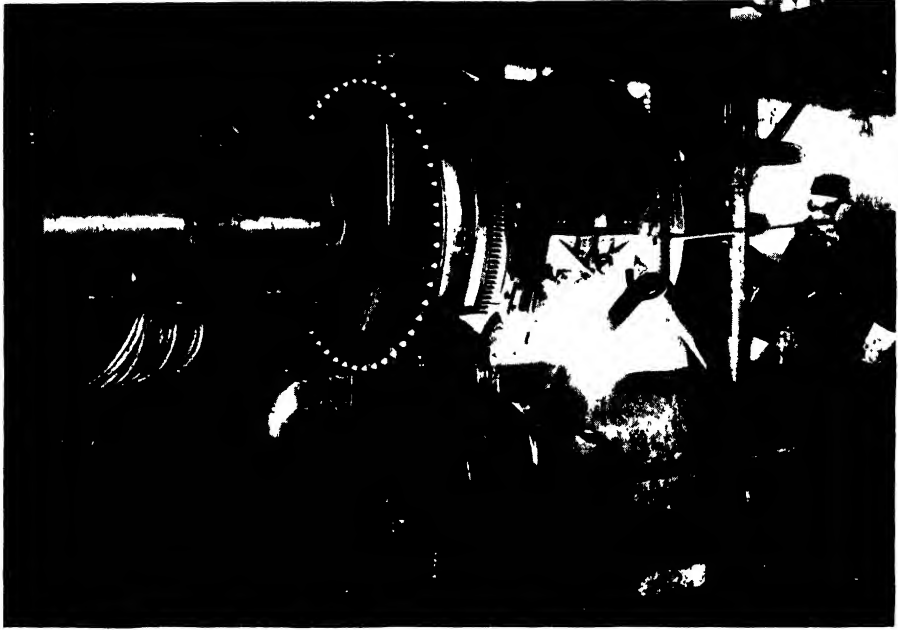


FIGURE 82a. (Upper) Type AA, 400-kw, 1000-lb Detroit rocking electric-arc furnace melting alloyed white iron and gray iron. b. (Lower) Cross sections of typical rocking-type arc furnace with conical shell construction. (Courtesy Detroit Electric Furnace Div., Kuhlman Electric Co.)

acid or basic. In order to facilitate mixing, the furnace may be either oscillating or rolling, although a stationary type sometimes is used.

#### INDUCTION FURNACES

In induction furnaces the heating effect arises from the resistance offered by the charge to the flow of an inductively produced eddy current. If a

current is passed through the primary of two electromagnetically linked circuits, a current also will be generated by induction in the secondary circuit. Since there is always an appreciable resistance in this secondary circuit, a considerable amount of heat may be so produced.

In the *Ajax-Wyatt* and *Ajax-Tama-Wyatt* furnaces, used for melting in the copper and brass and aluminum industries, respectively, and in the recently announced *Lindberg-Fisher* continuous pouring furnace, a low-frequency current is passed through a core transformer with the liquid metal bath forming the secondary circuit. In the *Ajax-Northrup*, or coreless induction furnace, a high-frequency current is passed through a hollow copper coil, usually water cooled, which surrounds a refractory crucible. The crucible may be either conducting or nonconducting, but either the crucible or the charge must have some electrical conductivity. By electromagnetic induction, a heavy enough secondary current is generated in any conductor placed within the field to melt it by direct resistance.

#### THE LOW-FREQUENCY INDUCTION FURNACE

The *Ajax-Wyatt* and *Ajax-Tama-Wyatt* *low-frequency* induction furnaces, as built today, have a maximum capacity of about 2500 lb of molten metal, of which only about 1800–2000 lb can be poured at one time because of the necessity of withholding sufficient molten metal in the furnace to maintain the secondary circuit. The construction of the furnaces is illustrated in Fig. 83. The actual secondary circuit is a comparatively small channel, at the bottom of the furnace, and shaped like a triangular or rectangular prism depending on the type. This must be filled with molten metal before operations can begin, and must be kept full if the furnace is to operate satisfactorily. Heat distribution and mixing of the metal in this passage is facilitated by two electromagnetic phenomena,<sup>4</sup> the *motor effect* and the *pinch effect*, both of which serve to maintain continual motion in the molten metal. Since the channel is placed vertically, the force of gravity acting upon the molten metal also serves to maintain a continuous bath.

The top leg of the secondary is integral with the bath, and by heat transfer between the molten metal and the solid charge, the latter is melted down fairly rapidly. This furnace finds its greatest application when charges of identical composition are to be melted for long periods of time, preferably the entire life of the furnace. Once the furnace cools, it usually must be relined, if only because of the cracking and spalling of the refractory. Any marked change in metal composition necessitates emptying the furnace and immediately refilling it with sufficient molten metal of the new

<sup>4</sup> See C. Hering, *Trans Am. Electrochem. Soc.*, **11**, 1907, 329; *ibid.*, **15**, 1909, 255; *ibid.*, **39**, 1921, 313.

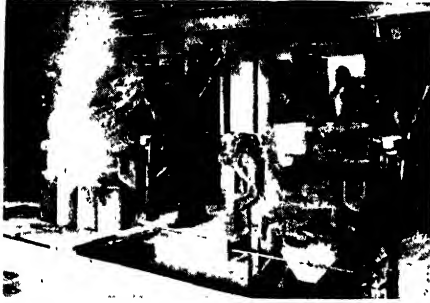
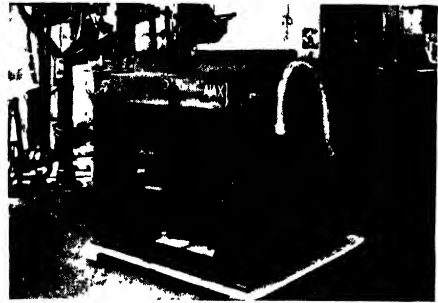
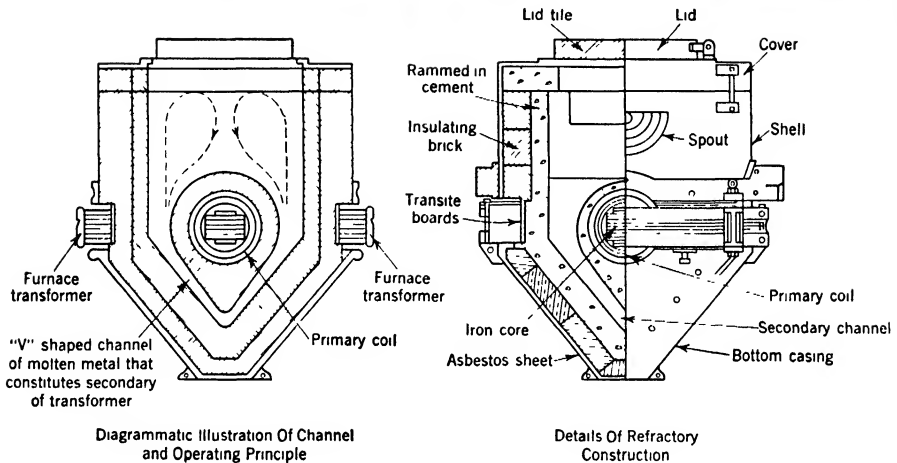
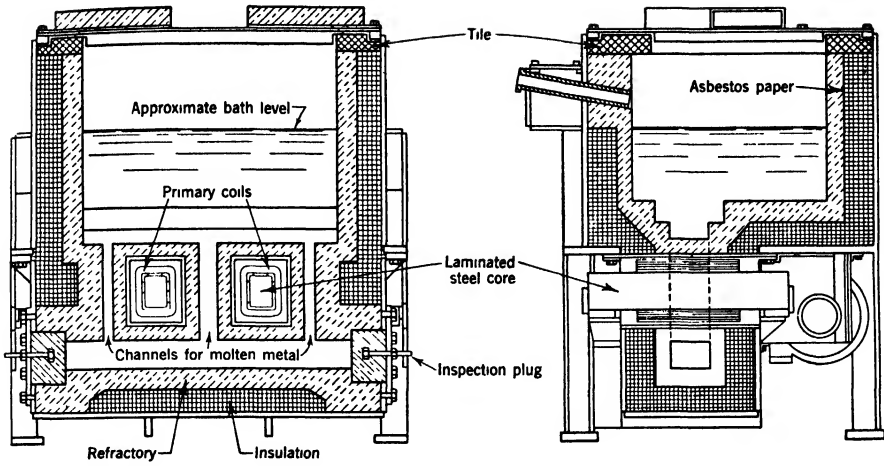
*a (Left)**a (Right)**b*

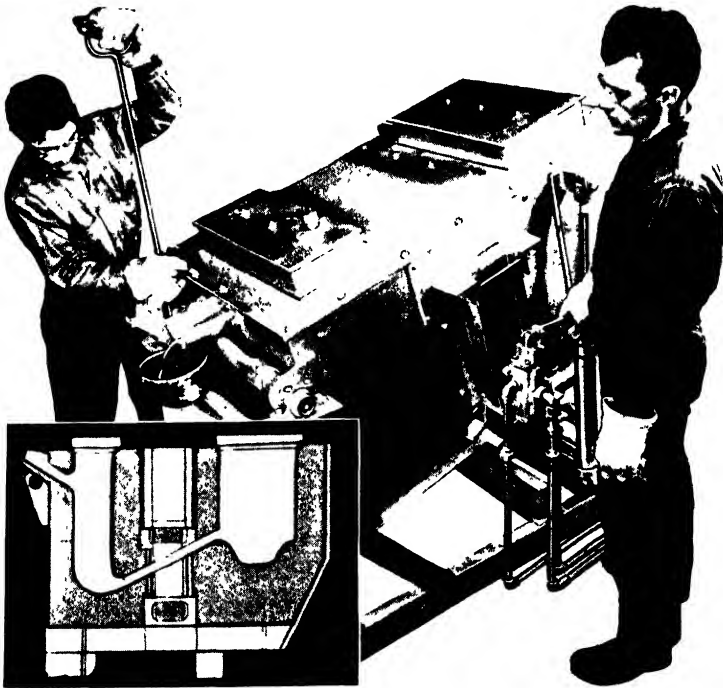
FIGURE 83. Low-frequency melting furnaces. *a*. The Ajax-Wyatt furnace used for copper alloys (*left*) and the Ajax-Tama-Wyatt furnace used for aluminum alloys (*right*). *b*. Diagrammatic illustrations of operating principle and construction details of the Ajax-Wyatt furnace. (Courtesy Titan Metal Manufacturing Co., Norton Company, and Ajax Electric Furnace Corp.)

composition. This risks possible damage to the lining, as well as possible contamination from the former charge. As a rule, these low-frequency induction furnaces are used only for melting, no impurities being removed.

The Lindberg-Fisher induction melting furnace (Fig. 83*d*), intended primarily for aluminum, brass, and zinc is a two-chamber unit which permits continuous pouring. A series of straight-line melting channels act as the real secondary circuit connecting the pouring chamber and the charging chamber. Because of the construction, the pouring chamber always contains clean residue-free metal at the proper temperature for pouring. The cooling effects of freshly charged metal and any dross or residue added with it appear only in the charging chamber and have little effect on the metal in the pouring chamber.



c



d

FIGURE 83 (continued). c. Cross sections of Ajax-Tama-Wyatt furnace showing some construction details. (Courtesy Ajax Electric Furnace Corp.) d. The new Lindberg-Fisher continuous-pouring induction melting furnace. (Courtesy Fisher Furnace Division, Lindberg Engineering Co.)

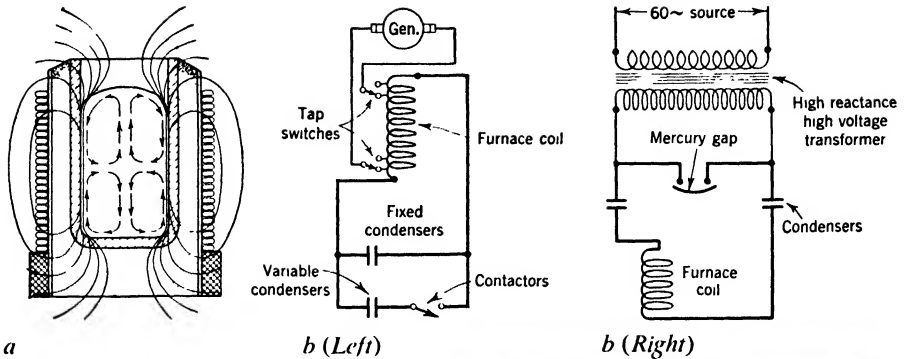


FIGURE 84. The Ajax-Northrup high-frequency electric induction furnace. *a*. Sectional view of Ajax-Northrup furnace showing magnetic field and stirring of molten charge. *b*. (*Left, right*) Simplified circuit diagrams of converters and furnace. *c*. 1-ton commercial furnace used for melting steel in the plant of the Wilber B. Driver Co. This is a 333-kw, 960-cycle unit and requires a little over 2 hr to melt a charge. (Courtesy Wilber B. Driver Co., and Ajax Electrothermic Corp.)



### THE CORELESS INDUCTION FURNACE

As made and used commercially, the high-frequency coreless induction furnace may vary in capacity from a fraction of a pound, in the precious metal industries, to the installations of 100-8000 lb capacity used in the steel industry. At the present time, the limiting holding capacity of this type of furnace appears to be about 5 tons, because of the difficulty of supporting the crucible, and it is doubtful if a 15-ton size ever will be exceeded. This is much smaller than the arc furnace. Induction furnaces are employed for melting only usually, and hence are much more rapid than the arc furnace in operation. The temperatures attainable are limited only by the available power, and almost any type of atmosphere or slag can be used in connection with them. The purity, also, is generally somewhat greater than can be secured with arc furnaces because of the elimination of the electrodes as a source of contamination, especially by carbon.

The furnace construction, illustrated in Fig. 84, is quite simple, although it is apt to be considerably more complex in the larger models because of the weight of metal to be sustained. The heat is developed in the charge by the heavy secondary current, mainly in the outer rim. However, it is quickly transmitted throughout by conduction. Once molten, mixing is facilitated

considerably by the strong motor effect produced in the liquid metal by the current. The resultant motion of the metal takes place in eddies, as indicated, and gives the bath a convex surface which varies in height with the power input. This stirring motion makes the use of a slag somewhat difficult except for low-power inputs.

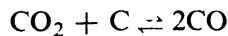
The high-frequency induction furnace has found its major use in the special- and high-quality alloy steel industry where metal can be made economically in small carefully controlled heats. Because of the difficulty in maintaining complete slag coverage, it is used largely for remelting and alloying rather than for refining. The third, or crucible, type of fuel-fired furnace has been replaced almost entirely by it for melting small lots of metal.

#### CARBON AS A METALLURGICAL REDUCING AGENT

When an oxide is reduced by an excess of carbon, the carbon itself will be oxidized simultaneously to one or both of its two oxides, CO and CO<sub>2</sub>. This chemical reaction, like all others, proceeds in a regular manner toward a definite equilibrium concentration, which is dependent upon the temperature and pressure. Although in most metallurgical processes involving reduction by carbon true equilibrium never is attained, still the conditions under which it exists are very helpful in understanding many of the reactions that occur.

#### THE EQUILIBRIUM BETWEEN C, CO, AND CO<sub>2</sub>

*In the presence of an excess of carbon*, the reactions between carbon and its oxides will proceed according to the equation:



When equilibrium has been attained there will be present definite percentages of CO and CO<sub>2</sub>, depending upon the temperature. This relationship between gas composition and temperature is shown in Fig. 85.

From this graph, it readily can be seen that, *for equilibrium conditions*, CO<sub>2</sub> cannot exist at temperatures higher than about 1900 F (1040 C) in the presence of excess carbon. If any should be present, because of non-equilibrium conditions, it will tend to react with the carbon to form CO.

Likewise, under equilibrium conditions, appreciable amounts of CO cannot exist in the presence of excess carbon below about 800 F (425 C). If any should be present because of nonequilibrium conditions, it will tend to decompose to carbon and CO<sub>2</sub>.



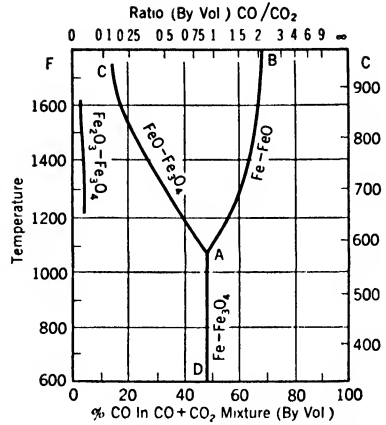
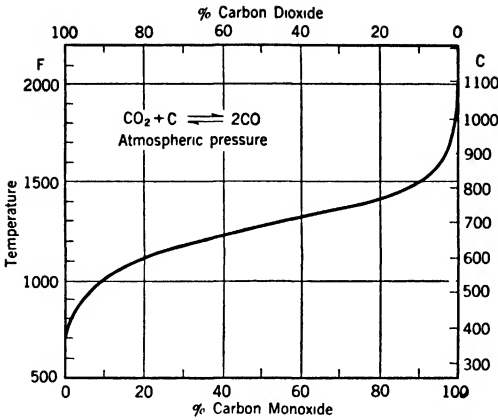


FIGURE 85. (Left) Equilibrium relationships between CO and CO<sub>2</sub> at various temperatures under atmospheric pressure and in the presence of excess carbon.

FIGURE 86. (Right) Equilibrium concentration of CO in reduction of iron oxides. (After J. B. Austin.) In order to reduce iron from FeO, and to keep it from being reoxidized at a given temperature, the final concentration of CO in the gas must be greater than the equilibrium concentration shown for that temperature by the line AB. Likewise the gas can reduce Fe<sub>3</sub>O<sub>4</sub> to Fe if the concentration of CO is greater than that shown by the line DA, and it can reduce Fe<sub>3</sub>O<sub>4</sub> to FeO if the concentration of CO is greater than that shown by the line AC.

Between these temperature limits, both gases can coexist in a definite ratio in the presence of free carbon, and they will tend to return to that ratio if it be disturbed in any way. This is in accord with *LeChatelier's principle*, which states that the application of a stress (i.e., a change in temperature, concentration, or pressure) to a system in equilibrium causes a reaction, displacing the equilibrium in the direction that tends to undo the effect of the stress. It also accords with *van't Hoff's law of mobile equilibrium*, a particular case of LeChatelier's principle, which states that if the temperature of a system in equilibrium is raised, the equilibrium point is displaced in the direction that absorbs heat. As pointed out earlier, under such conditions equilibrium will be attained much more rapidly at higher temperatures than at lower ones.

Practically, the equilibrium between carbon and its oxides indicates that (a) at temperatures above 1900 F (1040 C), since CO<sub>2</sub> cannot be stable, carbon itself must be the principal reducing agent, and CO is essentially inactive in this respect; (b) for temperatures below 1900 F (1040 C) and above 800 F (425 C) either carbon or carbon monoxide can serve as a reducing agent, forming carbon monoxide or dioxide, respectively; and (c) at temperatures below 800 F (425 C) only CO<sub>2</sub> will tend to form. However, in this low-temperature range the reactions are generally so sluggish that little chemical change takes place.

When dealing with ferrous materials, it also is known that mixtures of carbon monoxide and dioxide have no power to reduce the oxides of iron, and may even reoxidize iron already reduced, whenever the ratio by volume of CO to CO<sub>2</sub> in the gases is less than 49 to 51 or 0.96. This is expressed by the diagram reproduced in Fig. 86. It should be emphasized, however, that the significant ratio takes into account all sources of CO and CO<sub>2</sub>, whether these arise from the combustion of the fuel, the calcination of the flux, or some other source. It will be noted that this concept indicates a temperature of about 1100 F (595 C), as about the minimum for reduction of FeO by the oxides of carbon.

These statements may be considered to be approximately true although they have little exact significance because equilibrium, upon which they are based, probably seldom is approached in the metallurgical reactions to which they apply. The conditions also usually will be much more complex than expressed by this simple explanation.

#### *For Further Study Refer to*

1. *The Making, Shaping, and Treating of Steel*, 5th ed., by J. M. Camp and C. B. Francis: Carnegie-Illinois Steel Corp., Pittsburgh, Pa., 1940.
2. *Metals Handbook*: American Society for Metals, Cleveland, Ohio, 1939 (usually published triennially). A new edition will appear in 1948.
3. *Metallurgy of Iron and Steel*, 4th ed., by Bradley Stoughton: McGraw-Hill Book Company, Inc., New York, 1934.
4. *Milling Methods, Rocky Mountain Fund Volume*: Amer. Inst. of Mining and Metallurgical Eng., New York, 1934.
5. *Refractories*, 2d ed., by F. H. Norton: McGraw-Hill Book Company, Inc., New York, 1942.
6. *Reports of Refractory Committee*: The Iron and Steel Institute, London (issued at varying intervals).
7. *Ferrous Metallurgy*, by E. J. Teichert: McGraw-Hill Book Company, Inc., New York, 1944.
8. *Transactions Amer. Inst. of Mining and Metallurgical Eng.*, Iron and Steel Division: A.I.M.E., New York (published annually).

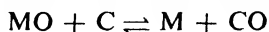
## IV Production of the Metals— Magnesium, Aluminum, and Zinc—from Their Ores

### GENERAL REDUCTION PRINCIPLES

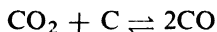
THE ENGINEERING METALS: MAGNESIUM, ALUMINUM, AND ZINC, are quite active chemically. Hence, unusual care must be taken in their production to ensure purity. It is not entirely feasible first to reduce the ore to metal and then to refine the metal, because the impurities which are apt to be present are usually less active chemically than the metal desired and therefore cannot be removed readily by inexpensive methods. As a rule, this necessitates the use of purely chemical methods of purification as a preliminary stage to the metallurgical reduction. Clearly, if the impurities can be removed by such methods before the actual reduction of the metal begins they cannot appear in the final product. With magnesium and zinc, also, additional purification is made possible by the use of vapor distillation because of the comparatively low boiling points of these two metals.

Since these three metals are all more active chemically than carbon, the commercial reduction of their oxides by it illustrates some interesting methods by which reactions, which would not be possible under equilibrium conditions, can be made to operate to a desired end point under nonequilibrium conditions.

The reduction of a metal from its oxide by carbon can be expressed by the general equation:



For any given set of conditions an equilibrium between the two opposing reactions will be set up just as for the reduction of carbon dioxide by carbon:



which has been discussed already. It also is found, for the two examples shown, that the reaction from left to right generally is *endothermic*, i.e.,

absorbs energy, and hence proceeds more readily at elevated temperatures, whereas the reaction from right to left is *exothermic*, i.e., liberates energy, and proceeds more readily at lower temperatures.

Three general methods are available for preventing the reverse reaction, i.e., right to left, from taking place to any marked extent, thus enabling the commercial production of these metals:

1. One of the constituents can be removed as rapidly as it is formed. For example, if the metal formed is only slightly volatile, the carbon monoxide can be removed continuously by any of several methods, thus preventing the reverse reaction from taking place.
2. Both of the products of the reaction can be removed together, and simultaneously cooled so rapidly that they will have little or no tendency to react. Thus, if the metal formed is volatile, both it and the carbon monoxide can be swept out of the reaction zone together. Rapid cooling of the mixture then will prevent reaction simply because, even with exothermic reactions, a certain intensity of heat energy or atomic mobility is required to start the reaction, and the sudden chilling makes this unattainable.
3. The products of the direct reaction can be formed separately. In the electrolytic reduction of molten salts, for example, the reduced metal is liberated at the cathode and the carbon monoxide, or other oxidized product, is liberated at the anode. By preventing contact between the two, as can be done readily by proper design of the equipment used, the reverse reaction is prevented quite effectively.

All of these general methods are illustrated in the reduction of the metals magnesium, aluminum, and zinc from their ores.

## *Magnesium*

### MAGNESIUM ORES

Magnesium is produced today chiefly from three sources:

1. *Magnesium chloride* ( $\text{MgCl}_2 \cdot \text{H}_2\text{O}$ , containing, when pure, 21.5% magnesium), and *carnallite* ( $\text{MgCl}_2 \cdot \text{KCl} \cdot 6\text{H}_2\text{O}$ , containing, when pure, 8.7% magnesium) derived either from salt deposits found in the vicinity of Midland, Michigan, or from sea water, containing 0.13% magnesium, taken from the ocean near Freeport, Texas.
2. *Magnesite* ( $\text{MgCO}_3$ , containing, when pure, 28.8% magnesium), and *dolomite* ( $\text{MgCO}_3 \cdot \text{CaCO}_3$ , containing, when pure, 13.7% magnesium) both of which are found in relatively large deposits in the states of Washington, California, and Nevada.

3. *Brucite* ( $\text{Mg}(\text{OH})_2$ , containing, when pure, 41.6% magnesium) which, until very recently, has not been used widely in the United States, even though quite extensive deposits of it occur in at least twelve states.

As a general rule, the ores contain relatively small percentages of magnesium, and must first be concentrated. Further, the naturally occurring minerals contain water of crystallization. This must be driven off to form either anhydrous magnesium chloride,  $\text{MgCl}_2$ , or the 85% dried salt,  $\text{MgCl}_2 \cdot \text{H}_2\text{O}$ , before the process of reduction can proceed because magnesium prepared and produced in the presence of too much water will tend to hydrolyze and form the hydroxide.

#### METHODS OF REDUCTION

Because of increased war production, the magnesium industry has undergone a tremendous expansion. As a result of this, six variations of the two basic processes: (a) electrolytic reduction and (b) chemical reduction, have been used or developed for use in the production of the metal. These are: (1) the *Dow chloride* process, (2) the *Elektron* process, (3) the *Dow sea-water* process, and (4) the *oxide* process, all of which depend on electrolytic reduction; (5) the *Hansgirk* process, using chemical reduction by means of carbon, and (6) the *Pidgeon* process, using chemical reduction by ferrosilicon. Although all of these have been used to some extent, their real test will come after the demand for metal becomes more stable, requiring the elimination of any processes or plants which cannot meet competitive costs. At this time, it is not possible to make any reliable predictions in this respect although the chloride and sea-water electrolytic processes seem most likely to continue in operation.

#### THE DOW CHLORIDE PROCESS

The Dow Chemical Company chloride process for producing magnesium by electrolytic reduction, a simplified flow sheet for which is shown in Fig. 87, uses the salt deposits found near Midland, Michigan, as its principal raw material. Until the present expansion of this industry, it was the only process in commercial operation in this country.

**PREPARATION OF ANHYDROUS CHLORIDE** When these brines are evaporated and crystallized, the hydrated salt,  $\text{MgCl}_2 \cdot 6\text{H}_2\text{O}$ , is secured. Heating this would cause it to decompose, according to the equation:



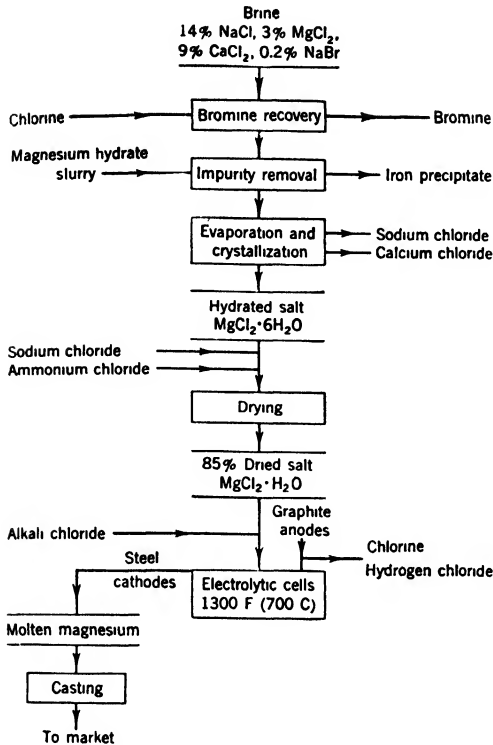
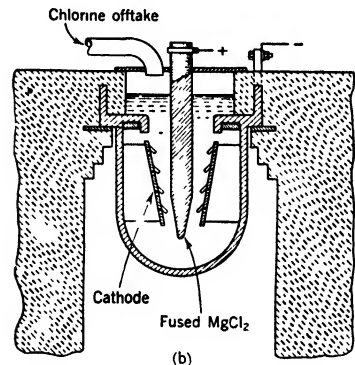
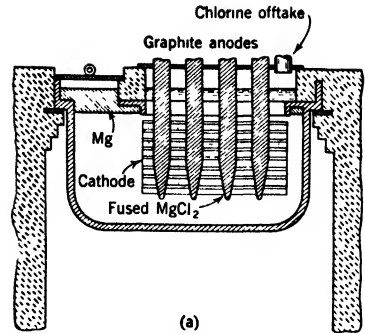


FIGURE 87. (Left) Simplified flow sheet of the Dow salt-brine process for producing magnesium.

FIGURE 88. (Right) Ward magnesium-chlorine cell. (From M. deK. Thompson's *Theoretical and Applied Electrochemistry* by permission of The Macmillan Company, publishers.)



However, this undesirable reaction can be prevented by first mixing with the hydrated magnesium chloride about 25% of sodium chloride plus a small amount of ammonium chloride. Heating this mixture at a low temperature drives off about half of the water of crystallization, and by then cooling this partly dried mixture and reheating at a higher temperature the remainder can be removed. The removal of the last molecule of water of crystallization is a rather difficult and costly process. Anhydrous magnesium chloride prepared by this method was the basis of the original chloride process, but most plants have now so modified their methods that 85% dried salt,  $\text{MgCl}_2 \cdot \text{H}_2\text{O}$ , is satisfactory. This yields a mixture of hydrogen chloride and chlorine in the electrolysis instead of pure chlorine.

**ELECTROLYSIS** A properly proportioned mixture of magnesium chloride and an alkali chloride is heated to about 1300 F (700 C) in a rectangular cast-steel cell similar to the one illustrated diagrammatically in Fig. 88.

External heat, frequently gas, must be used initially, and may be used also throughout the entire process. However, once the electrolysis is started, the current through the cell will maintain the temperature. Graphite anodes enter the open top of the cell. Chlorine, possibly mixed with some hydrogen chloride depending upon the exact process, will be liberated at the anode, and can be recovered. Molten magnesium will collect at the cathodes, which are so designed as to deflect the magnesium through holes to a collecting chamber.

Since the molten metal has a specific gravity lower than any of the salts employed, it will rise to the surface and must be protected there against oxidation. An iron cylinder may be used for this purpose. The molten magnesium is ladled out from time to time and cast into pigs weighing about 18 lb, and having an average purity of 99.9% magnesium.

**POWER REQUIREMENTS** . Each pound of magnesium will require 8–10 kw·hr, and 6–9 v ordinarily are used. Each cell consumes about 4000 lb of magnesium chloride, and produces about 1000 lb of metal per day.

#### THE ELEKTRON PROCESS

Another electrolytic process, using an anhydrous chloride electrolyte prepared in a somewhat different manner, was developed by the I. G. Farbenindustrie in Germany. It has been used successfully since by Magnesium Elektron, Ltd., in England, and hence sometimes is known as the M. E. L. process. A plant using this process was in commercial operation in this country near Las Vegas, Nevada, where cheap power from Hoover Dam is available. A simplified flow sheet is given in Fig. 89.

Magnesite is the principal raw material, although dolomite can be used. The ore is first finely ground and concentrated by flotation. It then is calcined to magnesia by multiple-hearth roasting. The calcined magnesia is ground, briquetted with coke and peat moss to make the mass spongy, and then treated with chlorine to convert it to anhydrous magnesium chloride for use in the electrolytic cells. This is done in a resistance furnace in the form of a tower (Fig. 90). The briquetted magnesia is charged into the tower, and converted to magnesium chloride which is tapped in the fused condition and fed to the electrolytic cells. The temperature in the chlorination tower is maintained at 1300–1650 F (700–900 C). By using anhydrous magnesium chloride in the electrolytic cell the chlorine given off at the anode can be collected, and reused in the chlorination tower. The electrolytic cell used in the Elektron process differs somewhat in design from the Ward cell, but follows the same general principles.

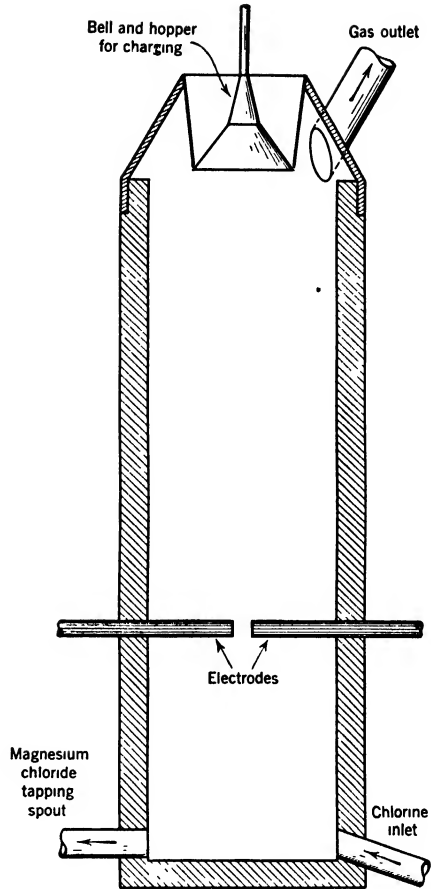
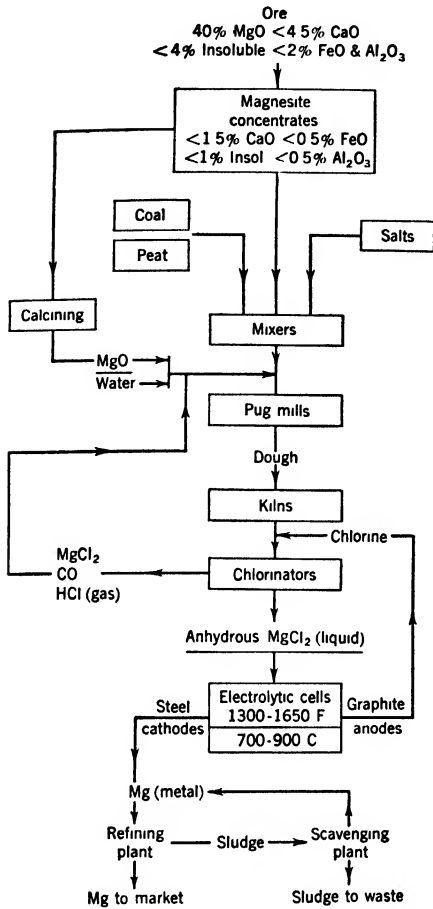


FIGURE 89. (Left) Simplified flow sheet of the Elektron (M. E. L.) process used for producing magnesium by Basic Magnesium, Inc., at Las Vegas, Nevada.

FIGURE 90. (Right) Type of electrical-resistance furnace used to make anhydrous fused magnesium chloride in the Elektron process (schematic).

THE DOW SEA-WATER PROCESS

Magnesium is found in raw ocean water in the ratio of about 1:770. This is being recovered now by the Dow Chemical Company in its plant at Freeport, Texas. A simplified flow sheet is illustrated in Fig. 91. There are four essential steps to the process:

1. *Precipitation* of magnesium hydrate,  $Mg(OH)_2$ , from the water under carefully controlled conditions, using milk of lime,  $Ca(OH)_2$ , made from oyster shells dredged from the bottom of Galveston Bay.
2. *Filtration* of the magnesium hydrate and *treatment* of it with 10%



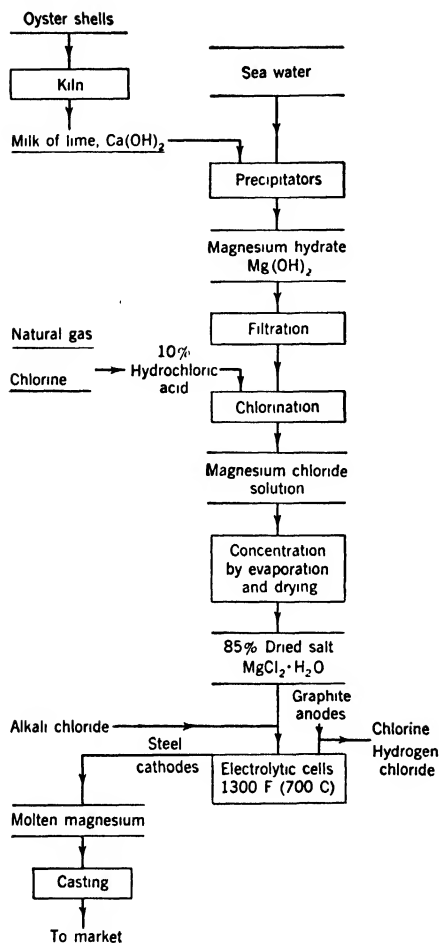


FIGURE 91. Simplified flow sheet of the Dow sea-water process for producing magnesium.

magnesium and bromine have been extracted can be discharged to the ocean at a point 7 miles away, thus producing no dilution of the entering supply.

#### THE OXIDE PROCESS

Production of magnesium by the electrolytic reduction of the molten oxide, as shown in the flow sheet of Fig. 92, was carried out by the American Magnesium Company until 1927, but then was discontinued because it could not compete economically with the chloride process. The process is mentioned here largely because of its historical interest and because it

hydrochloric acid, made synthetically by burning natural gas and chlorine, to convert it to magnesium chloride.

3. *Concentration* of the magnesium chloride by a complex process, requiring successive treatment in direct fired evaporators, shelf dryers, and rotary dryers, either to anhydrous or to 85% dried salt.
4. *Electrolysis* of the flaked magnesium chloride to produce metallic magnesium (99.9–99.95% pure), hydrogen chloride and/or chlorine gas (which can be then used to make hydrochloric acid) in a manner similar to that described previously under the chloride process.

The first unit using this process required the treatment of about 300,000,000 gal of water each day, and present capacity is about four times that of the original unit. The same water also is processed to remove bromine for use in the manufacture of tetraethyl lead for the gasoline industry.

Because of the unique location of the plant, the sea water from which

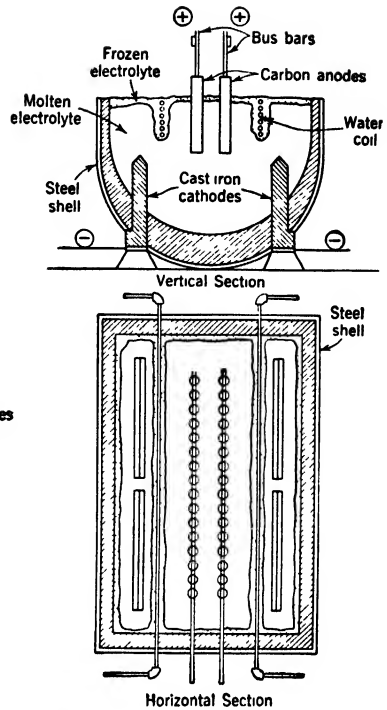
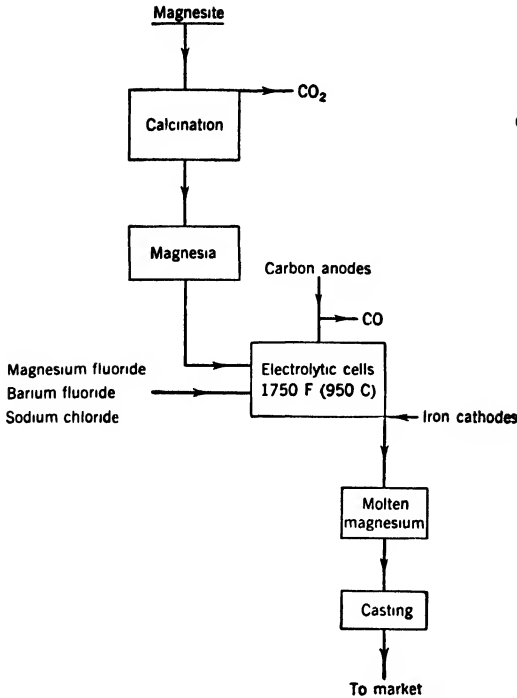


FIGURE 92. (Left) Simplified flow sheet of the oxide process for producing magnesium.

FIGURE 93. (Right) Magnesium oxide cell. (Reprinted by permission from *Non-Ferrous Production Metallurgy* by J. L. Bray, published by John Wiley & Sons, Inc., New York.)

employs magnesite and dolomite, two of the most widespread ores. At the present time its resumption seems very unlikely.

**THE FUSED ELECTROLYTE** Substantially pure magnesia can be prepared by the calcination of magnesite:



A small amount of this magnesia then can be dissolved in a molten electrolyte held at about 1750 F (950 C), and consisting of about equal parts of magnesium and barium fluorides (sp gr = 3.2). The viscosity of this bath can be adjusted by the addition of small amounts of sodium chloride. Although the solubility of magnesium oxide is only about 0.5%, sufficient excess oxide can be used to keep the bath constantly saturated.

**THE REDUCTION CELL** The reduction vessel (Fig. 93) is made of iron and supported on blocks. Cast-iron cathodes enter through the bottom of the vessel, and are connected to it electrically. Anodes of carbon or graphite are suspended from above in order to facilitate the removal of the carbon

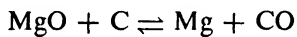
monoxide formed by their reaction with the liberated oxygen. Since the magnesium has a specific gravity lower than that of the bath, it will tend to rise to the surface as soon as it is liberated at the cathodes. In the molten condition, it must be protected from oxidation by the air. This is accomplished by utilizing the excess magnesia which is kept on the surface to replenish that dissolved in the bath. Cooling plates are arranged around the anode to solidify the molten material, and thus form vertical partitions of insulating salt. Near the outside, i.e., the cathodic iron pot, this also forms a protecting hood for the liquid magnesium which then may be tapped off as required.

**POWER REQUIREMENTS** These cells usually require about 9000–13,000 amp at 9–16 v and operate at a current efficiency of about 50% with a power efficiency of about 40%.

#### THE HANSGIRG PROCESS

After earlier trials in Austria, Korea, and Wales, a plant employing the electrothermic reduction process developed by Dr. Fritz J. Hansgirk was constructed in 1941 in Permanente, California. The general nature of this process is chemical and can be followed best from the simplified flow sheet in Fig. 94.

**PRINCIPLE** The basic reaction may be written



This reduction of magnesium oxide to magnesium by the use of finely divided carbon is carried out in an electric furnace at a temperature of approximately 3600–3800 F (2000–2100 C). Although the reaction, under these conditions, will proceed from left to right, it will reverse itself quickly, producing little or no magnesium, unless the products of the reaction, both of which are gaseous at these temperatures, are cooled rapidly to below 400 F (200 C).

**RAW MATERIALS** In the Permanente plant the magnesia is obtained by calcining either magnesite or brucite from Nevada. This calcine is mixed with petroleum coke and formed into briquettes, using pitch or hydrocarbon oils as binders, which are fed continuously into the reduction furnace, a totally enclosed, carbon-brick-lined, three-phase electric-arc furnace of 8000 kva capacity in the initial installation. Furnaces of much greater capacity may be used ultimately. An atmosphere of hydrogen was maintained in the furnace originally, but this has been changed to a less explosive gas in later developments.

**REACTION PRODUCTS** The reaction products, viz., magnesium vapor and carbon monoxide, are drawn off at one side and immediately chilled

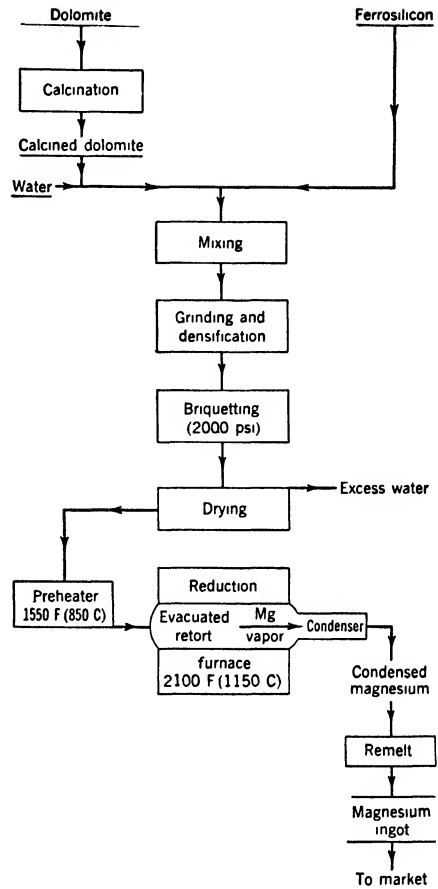
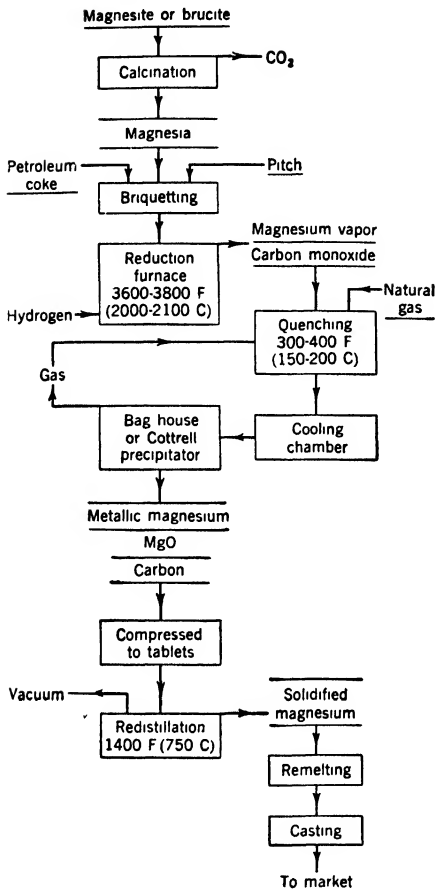


FIGURE 94. (Left) Simplified flow sheet of the Hansgier process as used for producing magnesium in the Permanente plant.

FIGURE 95. (Right) Simplified flow sheet of the ferrosilicon process for producing magnesium.

by a blast of natural gas. Approximately 25 volumes of natural gas are used for each volume of furnace vapor.

An interesting phase of the Permanente plant, and the one which was expected to enable it to compete economically with the other processes, is that this natural gas, which is used there as a cooling medium instead of hydrogen, is recovered and utilized as fuel by an adjoining cement mill. Hence, there is no necessity for any expensive equipment to purify it for reuse. The expense required for the purification of the hydrogen proved to be a serious obstacle in the earlier attempts to use this process.

After the initial quenching, the magnesium, along with certain impurities, is carried as fine dust into a cooling chamber. The temperature of the

gas has fallen by this time to 300–400 F (150–200 C), and the magnesium powder can be removed readily by collecting it in oil, by Cottrell electrostatic precipitators, or by passing the gas through large woolen bags. About 25% of the gas is recirculated and the remainder withdrawn for use in the cement mill.

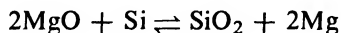
**REDISTILLATION OF THE MAGNESIUM DUST** The dust from this first stage contains 60–65% of metallic magnesium along with some magnesia and carbon. Before redistilling, it is compressed into tablets without a binder and then charged into totally enclosed, electrically heated retorts that operate at temperatures of about 1400 F (750 C) under high vacuum. Each of these retorts operated on a batch basis will yield, roughly, 1 ton of magnesium every 72 hr. The vaporized metal rises to the upper part of the retort, and is deposited there on the liquid cooled steel walls of a removable shell. After the distillation is complete, this upper shell is taken off, and the magnesium “doughnut” adhering to it is dumped. It then is remelted and cast into the form of pigs and ingots. The metal in this form has a purity of better than 99.97%, and as high as 99.997+‰ has been produced.

**POWER REQUIREMENTS** According to estimates, the total power requirements for the process will amount to about 9.5 kwhr per pound of magnesium. When running at full capacity, this plant will have an approximate daily electrical demand of 100,000 hp. It thus can be seen readily that a low-cost source of electrical power is also a prerequisite for successful operation of this process. This low-cost power has been found in the tremendous government-built hydroelectric projects in the Far West, which were constructed during the depression decade.

Thus far, the ultimate success of the Permanente plant seems to be somewhat uncertain, largely because of the numerous mechanical and operating problems which have arisen. The basic idea is undoubtedly sound, but gas explosions and other difficulties have curtailed production greatly. These may be overcome, however, by any of several modifications which are being tried out.

#### THE PIDGEON FERROSILICON PROCESS

A second direct chemical reduction process for magnesium (Fig. 95) was developed by Dr. L. M. Pidgeon in Canada. Magnesium oxide can be reduced by silicon in a vacuum according to the equation:



Aluminum, calcium carbide, carbon, or ferrosilicon also can be used as the reducing agent. Although this reaction is also reversible, metallic

magnesium can be made by it as long as it can be volatilized and removed continuously. This is not too difficult as the reaction takes place at about 2100 F (1150 C) in a vacuum.

In the commercial installations a high-grade pulverized ferrosilicon is used instead of silicon, and dolomite is the essential raw material. The reaction is carried out in large metallic reaction tubes 5–20 in. in diameter, heated either by electricity or gas. The vaporized magnesium condenses as a metal of high purity on water-cooled sections of the furnace or retort. The chief difficulty arises from the high operating temperature, and from the necessity of finding a metal which will have a reasonable life when used for reaction tubes at this temperature. A reaction-tube life as high as 6 months has been secured in a few isolated instances by the use of certain iron-nickel-chromium heat-resisting alloys, although the usual life is very much less because of the combined effects of surface oxidation and collapsing from atmospheric pressures outside working against the vacuum inside. Many of the difficulties were overcome by immersing the reaction tubes in molten glass. This served both to support the tubes and to protect them against surface oxidation. Also air under pressure frequently is applied periodically to the hot collapsed tubes in order to restore them to shape.

A pound of 75% ferrosilicon or its equivalent is required per pound of magnesium so this must be available from other sources and contributes substantially to the cost of the process. Even when electricity is used wherever possible, the power consumption is considerably below that of any of the electrolytic processes.

#### SPECIFICATIONS FOR COMMERCIAL MAGNESIUM

Magnesium ingot and stick for remelting are covered by A.S.T.M. Standard B92. According to this the maximum allowable amounts of impurity are:

Total % Al, Cu, Fe, Mn, Ni, Si	0.20
% Cu	0.05
% Ni	0.01

and the magnesium must be purer than 99.80% (by difference).

Iron is particularly troublesome since it is present in the free state and initiates galvanic corrosion. Practical freedom from this impurity is one of

the main advantages of the chemically reduced, and distilled, metal over that made electrolytically, although this advantage may be lost in the subsequent remelting.

## *Aluminum*

### ALUMINUM ORES

Aluminum is produced by the electrolytic reduction of aluminum oxide dissolved in a bath of molten cryolite. Despite the high percentage of aluminum in the earth's crust, only one ore was used in its production before the war. This was *bauxite*, a hydrated aluminum oxide: either  $\text{Al}_2\text{O}_3 \cdot 3\text{H}_2\text{O}$  or  $\text{Al}_2\text{O}_3 \cdot \text{H}_2\text{O}$  or a mixture of the two, with the oxides of iron, silicon, and titanium as impurities. The cost of separating the aluminum from lower grade ores is higher because of the low content of alumina and because of the impurities which are usually present.

In 1938 Germany produced about 30% of the world's supply of aluminum, closely followed by the United States with about 22%, Canada, U.S.S.R., and France. As a result of the war, increased United States production reached a peak of about seven times that of the prewar period.

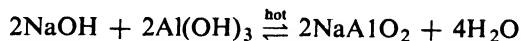
In the United States there are several large bauxite deposits although only those in Arkansas and a few in the southern states are used at the present time for the production of aluminum. Large quantities of ore are imported also from Surinam (Dutch Guiana) in South America.

### THE HALL-HEROULT PROCESS

Iron oxide, silicon oxide, and titanium oxide, all oxides of elements less active chemically than aluminum, are always present in bauxite as impurities. These first must be separated chemically from the ore in order to produce pure alumina,  $\text{Al}_2\text{O}_3$ , for reduction to aluminum. If these impurities are retained in the oxide they contaminate the aluminum and cannot be removed except by electrolytic refining, a process which is very expensive and impractical for large-scale production.

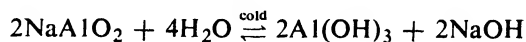
**PURIFICATION BY THE BAYER PROCESS** For purification, the process developed some fifty years ago by the Austrian chemist, Karl Josef Bayer, is used. In the *Bayer process*, shown diagrammatically as the first portion of the chart in Fig. 96, the thoroughly crushed, washed, and calcined bauxite is ground to a powder, mixed with a hot solution of sodium hydroxide, and then pumped into large pressure tanks called *digesters*.

Here caustic soda dissolves the aluminum hydroxide in the bauxite to form a sodium aluminate solution:



The impurities are attacked only slightly, and essentially remain in a solid form in which they can be filtered off as a *red mud* residue. A low silica content is desirable in the bauxite because silica causes the loss of both soda and alumina in the red mud, as sodium aluminum silicate.

The sodium aluminate solution then is pumped into large tanks, diluted with water and seeded with aluminum hydroxide crystals. As it cools, crystalline aluminum hydroxide separates:



Note that this equation is the reverse of the solution reaction, the only difference being in the temperature.

The aluminum hydroxide is separated from the solution and thoroughly washed free of caustic. The caustic solution then is concentrated, heated, and used to digest fresh bauxite; and the aluminum hydroxide is calcined in large rotating kilns to drive off its chemically combined water:



The powdery white alumina thus produced comprises about one-half the weight of the original bauxite. It is the principal raw material in the production of aluminum.

**THE ELECTROLYSIS** The Hall-Heroult process for the electrolytic smelting of alumina was discovered in 1886 by Charles Martin Hall, in Ohio, and Paul Louis Heroult, in France, working independently. For economical operation it requires large amounts of electrical power, and plants using the process, therefore, are scattered all over the country wherever cheap hydroelectric power is available.

The cells used, illustrated diagrammatically in Fig. 97a, are rectangular in shape, and are made of steel plates 1–2 in. thick. The cells are insulated thermally with alumina, and have a carbon lining 6–10 in. thick which serves as the cathode. Carbon anodes are suspended from overhead bus bars. Because of their intimate contact with the bath, these carbon electrodes must be of high purity themselves. Each cell will produce up to about 1000 lb of aluminum each day, and anywhere from 30 to 100 cells usually are operated in series.

*Alumina*,  $\text{Al}_2\text{O}_3$ , when dissolved in molten *cryolite*,  $3\text{NaF}\cdot\text{AlF}_3$ , can be decomposed electrolytically without changing the solvent. This is the



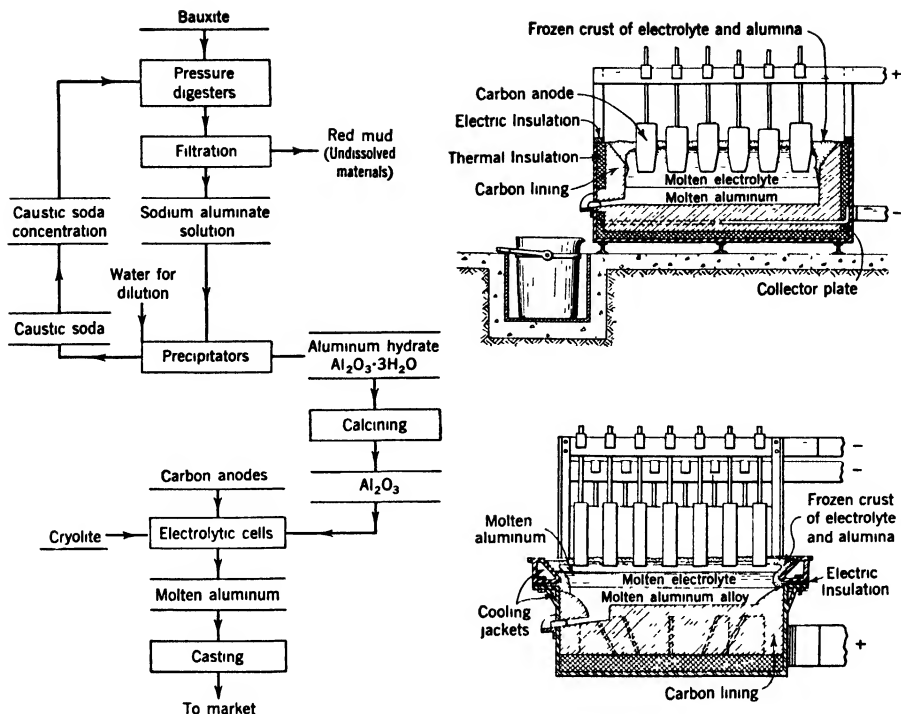


FIGURE 96. (Left) Steps in the purification of alumina by the Bayer process and the production of aluminum by the Hall-Heroult process.

FIGURE 97a. (Upper right) The Hall-Heroult electrolytic aluminum cell. (From *The Aluminum Industry* by J. D. Edwards, F. C. Frary, and Zay Jeffries: McGraw-Hill Book Company, Inc., New York.) b. (Lower right) The Hoopes electrolytic refining cell for making high-purity aluminum. (From *The Aluminum Industry* by J. D. Edwards, F. C. Frary, and Zay Jeffries: McGraw-Hill Book Company, Inc., New York.)

principle upon which the Hall-Heroult process is based. Although cryolite is found naturally only in Greenland, it can be synthesized readily. Either form may be used satisfactorily once the cell is started, but the natural form still seems to be desirable for starting.

The molten bath, which is maintained at about 1800 F (980 C) is composed of cryolite and may contain a small amount of calcium fluoride. Usually about 2–5% alumina is dissolved in it, although it will hold up to 20% in solution. Each pot consumes 8000–50,000 amp at a potential of about 6 v, most of which is used to overcome the resistance of the electrolyte. However, cells taking 55,000 amp have been in use since 1934 and larger ones may be built. The process is continuous, alumina being added periodically to replace that decomposed by the current. As electrolysis proceeds, the oxygen liberated at the anodes combines with the carbon,

and escapes through the crust which forms over the bath. The aluminum is deposited at the carbon cathode on the bottom of the cell. Since the bath is at a temperature above the melting point of aluminum the deposited metal remains at the bottom as a molten layer until it is tapped off and cast into pigs. Each of these pigs weighs about 50 lb and has a purity up to about 99.7%. The pigs are remelted to remove the dross and bath material before undergoing further fabrication.

Each pound of aluminum will require about 2 lb of alumina, 12 kwhr of electricity, and  $\frac{3}{4}$  lb of carbon electrodes. The current efficiency is usually 75–90%.

#### THE HOOPES ELECTROLYTIC REFINING PROCESS

Aluminum as high as 99.99% in purity can be produced in the Hoopes cell illustrated in Fig 97*b*, but the process is expensive and impractical for large-scale operation. It will be noted that there are now three molten layers in the cell instead of two as in the Hall cell. The bottom layer, a molten layer of a heavy copper-aluminum alloy, low in titanium and iron but containing some silicon, is the anode. Next is the layer of molten salt which constitutes the electrolytic bath. Finally, on top and in contact with the cathodes, is the molten cathodic layer of relatively pure aluminum (99.8% or better). In order to achieve this separation, barium fluoride must be added to the molten salt to increase its specific gravity to a point where it lies between that of the anodic and cathodic layers. This bath is operated at temperatures of the order of 1800 F (980 C).

#### SPECIFICATIONS FOR COMMERCIAL ALUMINUM

Aluminum ingots for remelting are covered by A.S.T.M. Standard B24, and classified according to their aluminum content (as determined by difference) into one of two grades: 99<sup>1</sup> and 99.75. The allowable percentages of impurities will vary with the grades as shown in Table X.

#### POSSIBLE COMPETITORS OF THE BAYER PROCESS

At the present time both the *Kalunite* and the *Ancor* or *lime-sinter* processes appear to have some possibility of becoming future competitors of the Bayer process for producing metal-grade alumina. However, it is probable that both of them will have to overcome certain economic deficiencies if they are to replace it even partially.

TABLE X A.S.T.M. CLASSIFICATION OF GRADES OF ALUMINUM INGOTS

GRADE	99+	99.75
(Max)		
% Cu	0.10	
% Fe	0.50	
% Si	0.30	
% Mg	0.05	
Others, each	0.05	
Total of all impurities	0.70	0.25
% Al (min)	99.30	99.75
by difference		

#### THE KALUNITE PROCESS

Fundamentally, the *Kalunite* process,<sup>1</sup> a simplified flow sheet for which is given in Fig. 98a, is applicable to any aluminum-bearing material that can be converted into a normal potassium alum or its equivalent. The process was developed actually, however, to convert the Utah alunite ores into alumina and potassium sulfate.

*Alunite*, essentially, is a combination of 1 unit of potassium alum,  $K_2SO_4 \cdot Al_2(SO_4)_3$ , with 4 units of aluminum hydroxide,  $Al(OH)_3$ , and varying amounts of water of crystallization. Commercial ores containing 18–33% alumina are available. The ore first is dehydrated in the range 850–1100 F (450–600 C) in order to eliminate the bulk of the water with a minimum loss of  $SO_3$  and to diminish the solubility of the iron content of the ore. Only the dehydrated alunite, called *metalunite*, will dissolve and react properly in the acid solutions conveniently available in the process.

This metalunite is given a countercurrent leaching with a boiling solution containing sufficient quantities of sulfuric acid and potassium sulfate to convert the valuable constituents to a 50% potassium alum solution, i.e., 50% by weight of  $K_2SO_4 \cdot Al_2(SO_4)_3 \cdot 24H_2O$  or, roughly, 75% water and 25% anhydrous salt. The bulk of the insoluble material in the solution can be separated by settling. Since the solubility of potassium alum is high at 200 F (92 C) and only about 10% by weight at 68 F (20 C) pure potassium alum crystals can be crystallized out merely by cooling the muddy solution. A potassium alum mother liquor first is mixed with the 50% solution in

<sup>1</sup> See also, A. Fleischer, *A.I.M.E. Tech. Pub. No. 1713*, 1944.

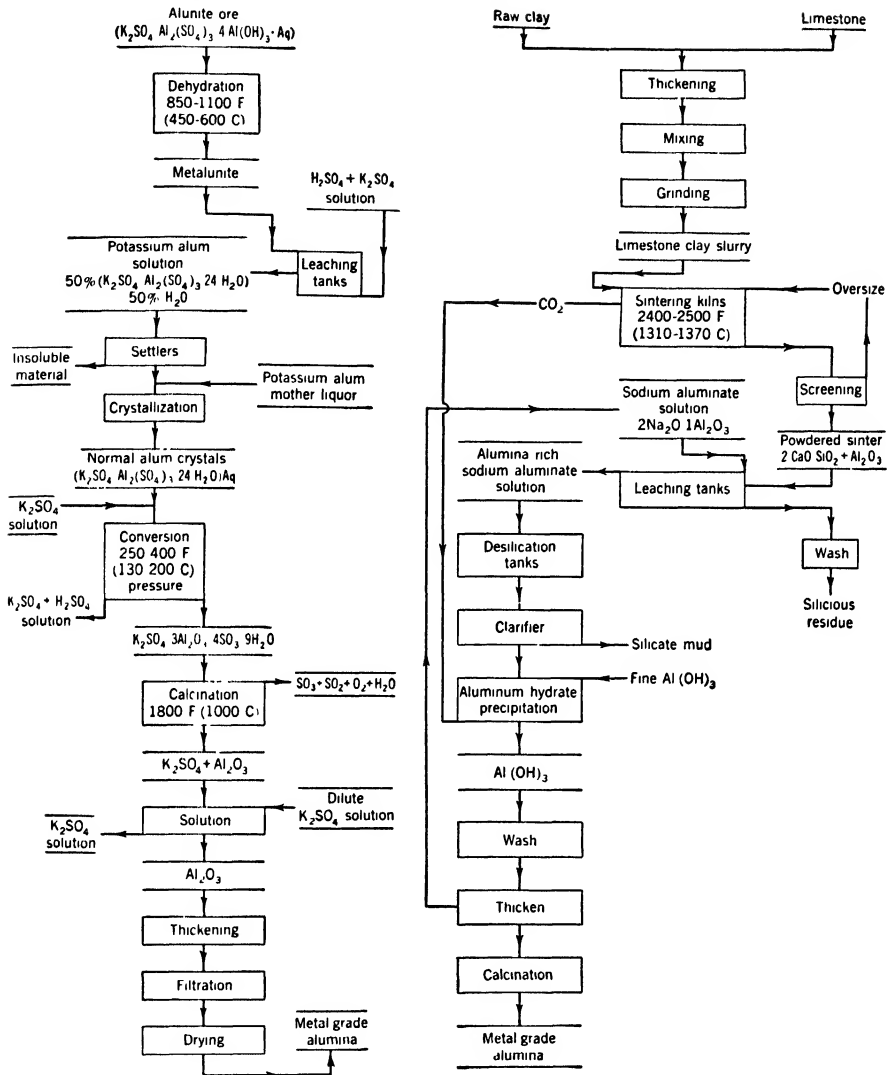
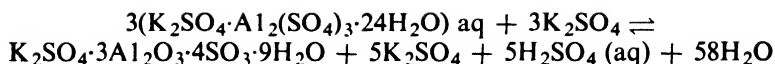


FIGURE 98a. (Left) Simplified flow sheet of the Kalunite process for producing metal-grade alumina. b. (Right) Simplified flow sheet of the Ancor lime-sinter process for producing metal-grade alumina.

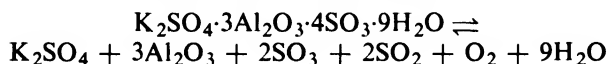
order to cool it and to start crystallization. Filtration also can be used previous to the crystallization, but some of the ores yield solutions which filter only with great difficulty for a reason not as yet clearly understood.

The normal alum crystals then are separated and heated, under pressure, in the range 250–400 F (130–200 C) in order to convert them to a water-insoluble basic alum according to the equation:



The pressure is necessary to avoid evaporation of the solution formed by the crystals dissolving in their own water of crystallization and to secure a temperature sufficiently high for the reaction to occur. Note that both of the basic reagents, potassium sulfate and sulfuric acid,  $\text{K}_2\text{SO}_4$  and  $\text{H}_2\text{SO}_4$ , are regenerated in this stage of the process.

By calcining this water-insoluble product at about 1830 F (1000 C) all the unwanted products can be driven off as gases as shown by the equation



The potassium sulfate remaining then can be dissolved with water or with a dilute ( $\text{K}_2\text{SO}_4$ ) solution leaving a residue of alumina which, after separating by thickening and filtration, can be dried at a low temperature and is supposedly ready for direct reduction to metal by the Hall-Heroult process.

#### THE ANCOR PROCESS

The *lime-sinter* process<sup>2</sup> was developed primarily to extract alumina from a kaolin-type South Carolina clay.

The process derives its name from its basic idea which is the use of lime,  $\text{CaO}$ , from limestone for fixation of the silica in the raw clay as a calcium silicate. It is a modification of the lime-soda-sinter process which also uses soda,  $\text{Na}_2\text{O}$ , for silica fixation in addition to the lime. As shown in the simplified flow sheet in Fig. 98*b*, these raw materials first are mixed into a slurry which is filtered and passed through kilns at 2400–2500 F (1310–1370 C) to cause the formation of dicalcium silicate,  $2\text{CaO} \cdot \text{SiO}_2$ . Properly prepared sinter is a fine powder and any coarse material is returned to the kiln for retreatment.

The powdered sinter then is subjected to a countercurrent leaching and filtering at about 145 F (63 C) using a sodium aluminate solution containing a 2:1 mole ratio of  $\text{Na}_2\text{O}$  to  $\text{Al}_2\text{O}_3$  and a concentration of 85 g  $\text{Al}_2\text{O}_3$ , or its equivalent, per liter of solution. Ordinarily the silica dissolved is about 1.5–3% of the alumina extracted.

This dissolved silica may be kept to a minimum by careful attention and balancing in the preceding stages or by converting it into an insoluble compound, e.g., sodium aluminum silicate, by treating the leaching liquor.

After the desilication treatment the solution is filtered to clarify it and is then diluted, cooled, and seeded with fine aluminum hydrate to precipi-

<sup>2</sup> See also F. R. Archibald and C. F. Jackson, *A.I.M.E. Tech. Pub. No. 1706*, 1944.

tate alumina. Simultaneous carbonation facilitates this precipitation and regenerates the sodium carbonate which is returned to the leaching cycle.

After classification, filtration, and calcination, as in the Bayer process, the alumina is supposedly suitable for use in making metal.

### *Zinc*

The metal zinc has a sufficiently low boiling point to enable it to be purified by distillation, and it is sufficiently inactive chemically to be electrodeposited from aqueous solutions. However, it is still sufficiently active to require carefully controlled conditions in either the fire-refining or electrolytic methods. All of these factors influence the processes used for its commercial production.

About 35% of the zinc produced in the United States is made by electrolytic methods; and about 75% by methods involving reduction with carbon and distillation. Before World War II, the United States produced about 40% of the world's supply of zinc, with Belgium, Germany, Canada, and Poland furnishing most of the remainder. However, a major portion of the United States production was produced and used in the form of zinc oxide, ZnO, rather than metallic zinc which is the only material discussed here.

In addition to their importance as zinc producers these processes, especially the electrolytic process, provide the only important sources of cadmium, indium, and germanium.

### ZINC ORES

The Tri-State or Joplin region (Kansas, Missouri, and Oklahoma), New Jersey, Idaho, Montana, Utah, New York, and Tennessee supply the majority of the zinc ores in this country.

The six ores of zinc in use today are listed in Table XI.

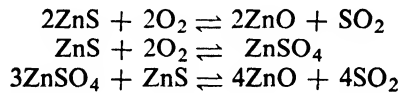
TABLE XI COMMON ORES OF ZINC

NAME	FORMULA	% ZINC WHEN PURE
<i>Calamine</i>	$\text{ZnO} \cdot \text{Zn}(\text{OH})_2 \cdot \text{SiO}_2$	54.2
<i>Franklinite</i>	$(\text{ZnO}, \text{MnO}) \cdot \text{Fe}_2\text{O}_3$	6-18
<i>Smithsonite</i>	$\text{ZnCO}_3$	52.1
<i>Sphalerite</i> or <i>Black Jack</i>	$\text{ZnS}$	67.0
<i>Zincite</i>	$\text{ZnO}$	80.3
<i>Willemite</i>	$2\text{ZnO} \cdot \text{SiO}_2$	58.6

Generally, ore deposits average about 3% zinc, and must be concentrated to about 55% zinc. This usually is done by gravity concentration, by flotation, or by heavy solution separation.

#### PRELIMINARY TREATMENT

All of the ores are crushed if they are not already sufficiently fine as a result of the concentration process. The sulfide ores must be roasted or heated in air at 1500–1550 F (815–845 C) to convert them either to zinc oxide, or to a mixture of zinc oxide and zinc sulfate if the ore is to be treated by a distillation method, according to the equations:



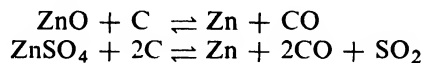
If the ore is to be treated electrolytically, the water-soluble zinc sulfate may be formed instead of the oxide by roasting in the lower temperature range 1300–1350 F (700–735 C), although this is not too important if a sulfuric acid solution is used as a solvent. In either case, the amount of sulfide left after roasting should be as low as possible.

Carbonate ores frequently are calcined to drive off the carbon dioxide and to dry them. This may be done in the actual reduction process, however, rather than separately.

The silicate ores can be used directly in the distillation process although they usually are blended or mixed with some of the other ores.

#### THE DISTILLATION PROCESS

**PRINCIPLE** The prepared ores are mixed with a carbonaceous reducing material, and heated in closed retorts until as much of the zinc oxide as possible has been reduced to metallic zinc vapor:



At the temperature of operation this vapor is distilled from the retorts into a condenser where it condenses to the molten state. These reactions will take place as low as 1400 F (760 C), but the retorts frequently are operated considerably higher than this in order to speed up the distillation of the zinc, which boils at about 1660 F (905 C).

**METHODS OF OPERATION** Three methods have been developed for carrying out these reactions efficiently:

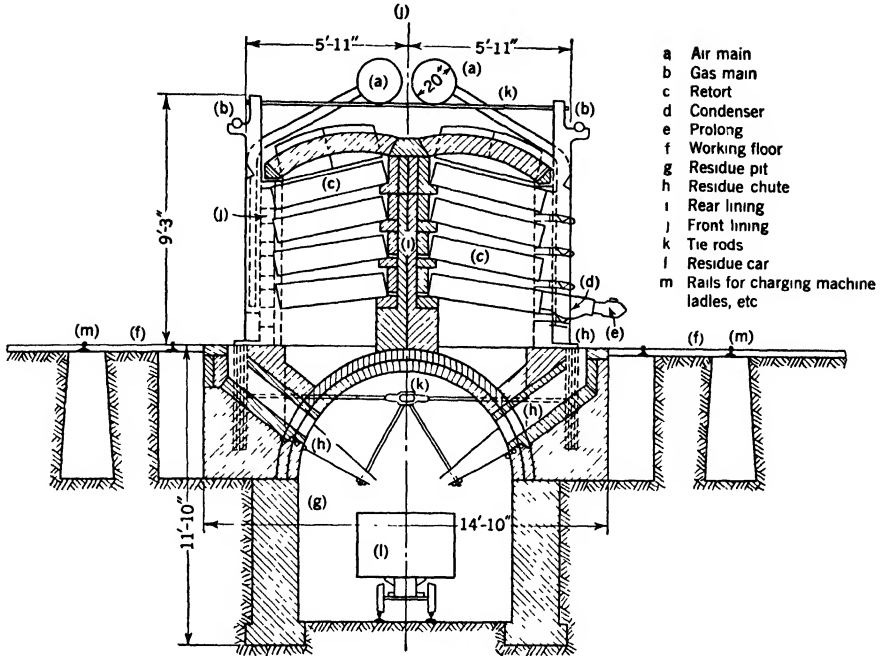


FIGURE 99. Diagrammatic cross section of a Belgian-type horizontal-retort zinc distillation furnace. (Reprinted by permission from *Non-Ferrous Production Metallurgy* by J. L. Bray, published by John Wiley & Sons, Inc., New York.)

1. The *Belgian-type horizontal-retort* process.
2. The *New Jersey Zinc continuous vertical-retort* process.
3. The *St. Joseph Lead Company's electrothermic* process.

A fourth process, the *Waelz rotary kiln* process, recovers zinc from ores largely in the form of the oxide instead of the metal, but is very useful under some conditions in spite of this fact.

#### THE HORIZONTAL RETORT PROCESS

In Fig. 99 a diagrammatic cross section of a Belgian-type zinc distillation furnace is shown, and in Fig. 100 a simplified flow sheet of the process. Each furnace has two units built back to back to save space and to reduce radiation losses. Each unit will hold about forty-eight retorts, circular or elliptical cylinders, customarily about 60 in. in length, 11 in. in diameter, and closed at one end. These usually are arranged in four vertical rows of twelve each. Each retort is supported at a slight incline in the furnace with the closed back end somewhat higher than the mouth. Fire-clay condensers about 18 in. long and 6 in. in diameter at the larger end are inserted into



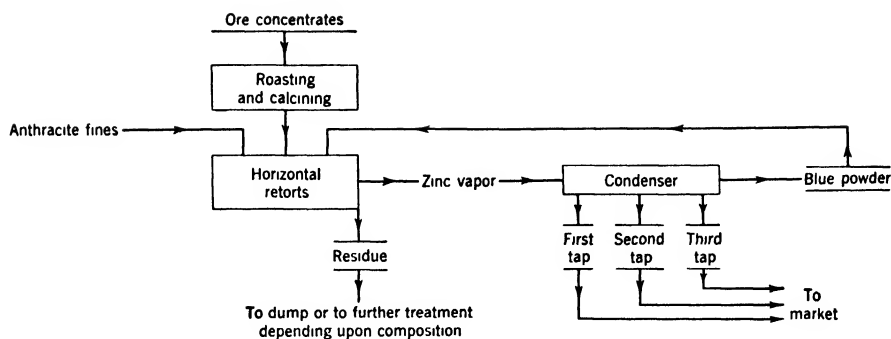


FIGURE 100. Simplified flow sheet of the horizontal-retort zinc distillation process.

the open end of the retort, and sealed with fire clay. The retorts, which may be made of fire clay or carborundum and may last from 20–40 days, will hold about 135 lb of charge. The average life of the furnace as a whole is about 4–5 yr.

**CYCLE OF OPERATION** The charge, which may be introduced either by hand or by a charging machine, contains about 30–40% reducing fuel with the balance ore and recharged material. It is desirable to obtain complete reduction, if possible, and to maintain an atmosphere of carbon monoxide. Either anthracite fines or coal crushed to about  $\frac{1}{4}$  in. diameter make an excellent fuel for this purpose.

When the retorts are charged and the condensers are fixed in position, the furnace is heated as rapidly as possible to about 1830 F (1000 C). The time at which the retorts reach the correct temperature can be detected by the carbon monoxide gas burning at the mouth of the condenser. From this point onward the temperature is adjusted so as to maintain a steady distillation rate.

The first product to come over is called *blue powder*, an intimate mixture of finely divided zinc and zinc oxide. This will contain also much of the cadmium if cadmium is present. The blue powder is collected and recharged later. As the temperature of the condensers rises to the proper operating range, 800–1000 F (425–540 C), the amount of blue powder decreases markedly. The zinc will begin to come over about 6 hr after charging. As the condensers fill, the zinc is removed to a ladle or a kettle, and cast into bars for market. This removal or drawing may take place from two to six times a cycle. For tapping three times a cycle, about 40% of the zinc recovered is removed in the first draw, 50% in the second, and 10% in the third. The purity depends on the tapping, the first tap generally being most pure, and the last tap least pure. The principal impurities are *lead*, *iron*,

*cadmium*, *copper*, and *arsenic*, depending to some extent on the ore used.

#### HORIZONTAL-RETORT REDISTILLATION

If this zinc or spelter is not of sufficient purity, it can be redistilled to give metal containing better than 99% zinc. Reflux distilling even will produce a 99.997% grade.

Redistillation is carried out in essentially the same way as the original reduction, although the retort differs somewhat in design, and the temperature can be considerably lower. Each redistillation naturally increases the cost and the zinc loss, so all the higher purity grades command an appreciable premium.

#### THE CONTINUOUS VERTICAL-RETORT PROCESS

The development of the vertical-retort process<sup>3</sup> in the period 1925–29 by the New Jersey Zinc Company, holder of numerous United States and foreign patents on it, resulted in the production of a purer grade of zinc at lower cost by methods of reduction that not only were more efficient, but also were easier on the laborers employed.

The relation between the three principal steps in the process, viz., *briquetting*, *reduction*, and *condensation*, can be understood from the flow sheet shown in Fig. 101.

**BRIQUETTING** The briquettes, which must retain their shape throughout the process if it is to operate satisfactorily, are made by mixing oxide zinc ore with reducing agents and binders. For best results, at least part of the carbonaceous material should be coking coal. The briquettes are dried and finally coked in a continuously operated but intermittently charged process, using the exhaust combustion gases from the firing chamber that supplies heat to the vertical retort. This gas enters at 1350–1650 F (730–900 C) and leaves at 570–1300 F (300–700 C).

**REDUCTION** The reduction is carried out in a vertical retort, made of silicon carbide, having a heated height of about 25 ft and a rectangular cross-section 1 ft by 6 ft.

The retorts are heated by producer gas. They operate continuously, but are fed through the top in batches, and discharge continuously at the bottom where there is a water seal to prevent loss of vapor. The reduction of zinc under these conditions is an endothermic process. Hence, both the

<sup>3</sup> See, for a more detailed description, E. H. Bunce and E. C. Handwerk, *Trans. A.I.M.E.*, 121, 1936, 427–440.

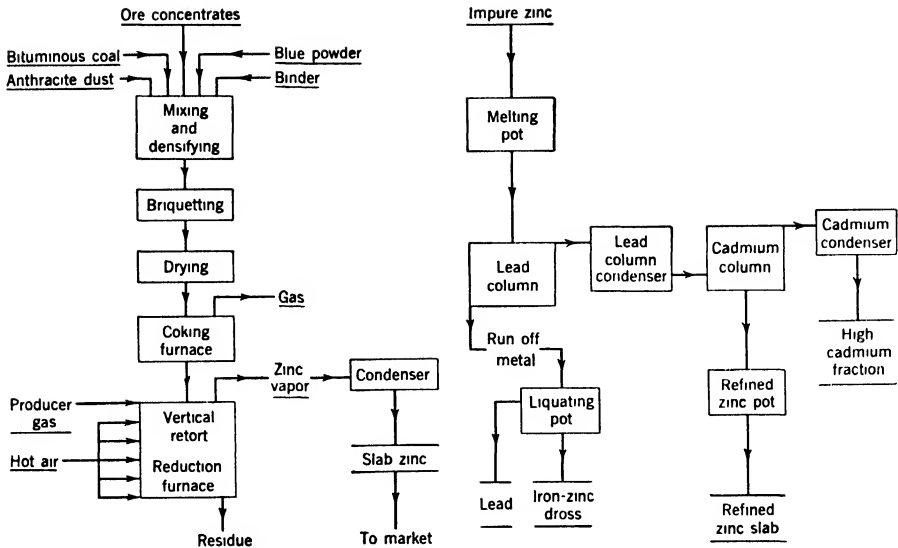


FIGURE 101. (Left) Simplified flow sheet of the vertical-retort zinc distillation process.

FIGURE 102. (Right) Simplified flow sheet of the process for refining zinc by redistillation.

rate of reduction and the producing capacity are governed by the amount of heat that can be introduced into the charge. Production should average about 30 lb of metallic zinc per 24 hr per square foot of heated long wall surface, with 92% recovery when operated at 2370 F (1300 C). A normal retort life is 3–5 yr because of the uniform conditions under which they operate.

A vertical extension of the retort which precedes the condensers serves to filter out the blue powder and zinc dust from the gases.

**CONDENSATION** The condensers are constructed of silicon carbide plates with alternating baffles to produce a zigzag and turbulent flow of the vapors and to give a high rate of heat transfer. Since there is a continuous supply of large volumes of gases of a uniform composition and temperature, the condensers can be fairly large and still operate efficiently under the optimum conditions.

There are two main parts to the condensers:

1. A cool portion, designed to cool the gases rapidly.
2. A zinc sump where the molten zinc collects and where the cooling and condensation of the zinc vapor is slow enough to avoid the formation of blue powder.

Each tapping of the condenser sump, about every 5 hr, yields about 1½ tons of zinc.

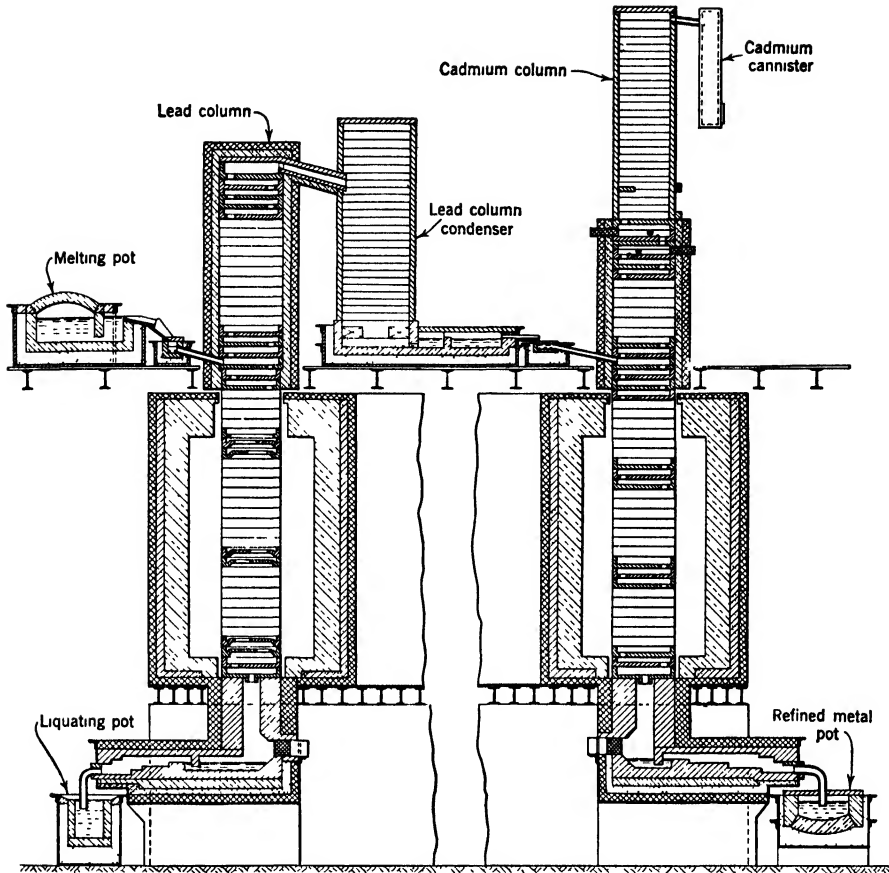


FIGURE 103. Schematic layout of the New Jersey Zinc Company vertical furnace for the redistillation of zinc. (From W. M. Peirce and R. K. Waring, *Trans. A.I.M.E.*, **121**, 1936, 449.)

The exhaust gases are scrubbed to collect zinc dust, which, with the blue powder, is recirculated.

#### REDISTILLATION OF VERTICAL-RETORT ZINC

The modern redistillation process,<sup>4</sup> a simplified flow sheet for which is shown in Fig. 102, is carried out in a vertical furnace, Fig. 103, also developed by the New Jersey Zinc Company, composed of trays specially shaped to give the maximum surface for heat absorption. Because of the different boiling points of *zinc*, 1660 F (905 C), *cadmium*, 1430 F (780 C), and *lead*, 2950 F (1620 C), a form of fractional distillation can be used successfully to produce zinc as high as 99.99+ % pure.

<sup>4</sup> See, for further details, W. M. Peirce and R. K. Waring, *Trans. A.I.M.E.*, **121**, 1936, 445-452

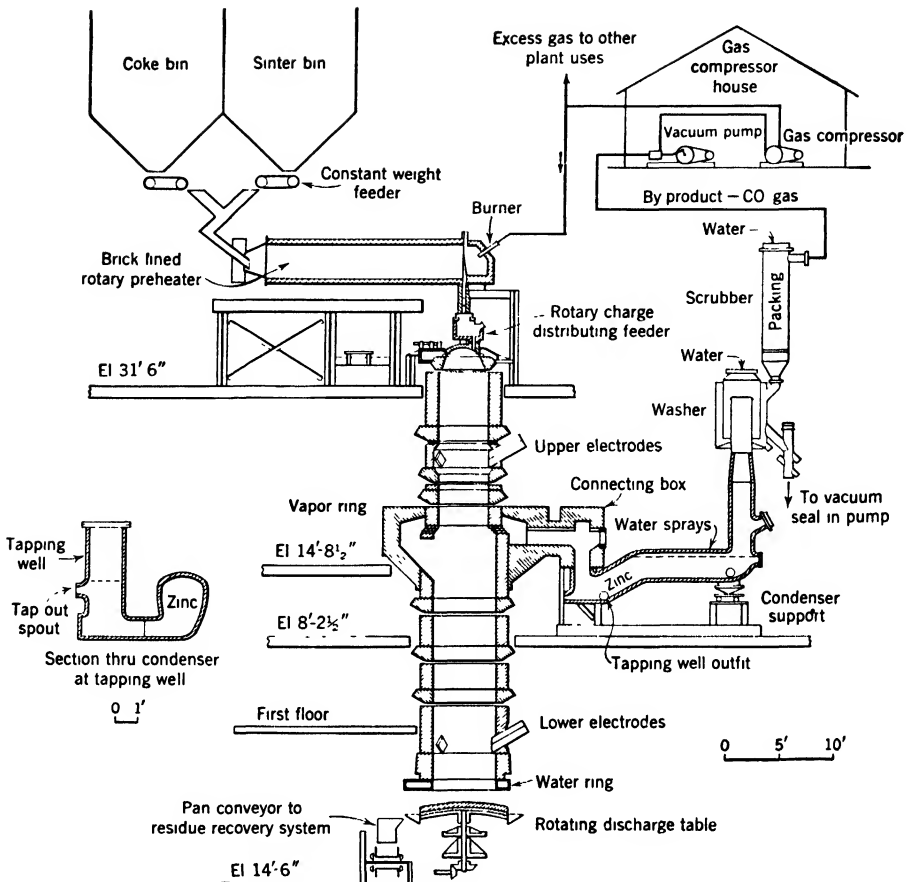


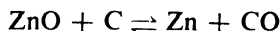
FIGURE 104. Schematic layout of furnace and condensing equipment in St. Joseph Lead Company's electrothermic process for refining zinc. (From G. F. Weaton and C. C. Long, *Metals Tech.*, A.I.M.E., Feb. 1939.)

#### THE ST. JOSEPH LEAD COMPANY'S ELECTROTHERMIC PROCESS

In Fig. 104, the general layout of the equipment developed by the St. Joseph Lead Company in the period 1926–30 for the electrothermic reduction of zinc<sup>5</sup> is shown. A constant ratio of coke and zinc ore sinter is mixed in a rotary, gas-fired, brick-lined, kiln preheater, which is maintained at 1380 F (750 C). The mixture then is fed into the furnace through a rotating distributor top. The furnace charge, 25 tons, serves as a current-carrying medium and is heated by its own resistance. Two sets of three horizontal electrodes spaced 24 ft apart vertically are used, and the

<sup>5</sup> See, G. F. Weaton, *Trans. A.I.M.E.*, 121, 1936, 599–609.

total daily input to the furnace is about 29,000 kwhr. The temperature in the charge will vary somewhat because of variations in its resistance, but will average about 2200 F (1200 C). The reaction is similar to that in the other distillation processes:



the zinc vapor and carbon monoxide passing first into an encircling vapor ring, and thence to the condenser. The gas temperature at this point is just above the temperature at which zinc will begin to condense, about 1525 F (830 C).

The gases are condensed to metal continuously by bubbling them through a bath of molten metal, weighing about 11 tons, in a condenser shaped like a U-tube. By keeping the exit arm of this tube under a vacuum, a continuous agitation of the metal is produced by the intermittent passage of bubbles of vapor through it with concomitant release of the vacuum. This efficiently scrubs the gas.

This furnace will treat about 40 tons of charge daily with an over-all recovery of about 93%. About 2550 kwhr are used per ton of zinc.

#### THE WAELZ PROCESS

Many ores and metallurgical residues contain small amounts of zinc that may be recovered profitably and efficiently by volatilization in a rotary kiln by the Waelz process<sup>6</sup> (from the German word *waelzen* meaning a "trundling motion"). The ore or residue is mixed with a solid carbonaceous reducing agent and fed into a horizontal rotary kiln where it is dried and heated by hot gases flowing in the opposite direction. A strong reducing atmosphere, at the temperature existing within the charge, frees the metal and volatilizes it. This metallic vapor, as well as the carbon monoxide present, then is reoxidized in the oxidizing atmosphere above the charge in the kiln, and the zinc is recovered in bag houses as zinc oxide.

For successful operation, thorough mixing with some form of cheap solid fuel, such as coke breeze or anthracite fines, is essential. By the use of a long reduction zone and careful control of the maximum temperature of operation in order to prevent the charge from slagging and becoming fluid, even complex zinc compounds, like ferrites and silicates, can be reduced. This makes the process valuable for treating low-grade complex zinc ores, such as are found in the western states. The labor requirement is also small, a definite advantage.

<sup>6</sup> See W. E. Harris, *Trans. A.I.M.E.*, **121**, 1936, 702-720.

## ELECTROLYTIC DEPOSITION OF ZINC

Zinc has been produced commercially by electrolytic methods since about 1915.<sup>7</sup> Sulfide ores are roasted under conditions suitable for producing the right proportions of sulfate and oxide and then are leached with dilute sulfuric acid. This solution first is filtered to remove iron, which will be present as the hydroxide if the acidity of the leaching solution is controlled properly. The solution then is heated with steam coils, and treated with zinc dust to precipitate copper and some of the other impurities. These impurities are removed as a sludge by filtration.

The purity of the solution is very important because the decomposition voltage of zinc sulfate is so close to that of water that, unless proper conditions are maintained, hydrogen will be given off at the cathode instead of zinc. Even a few parts per million of some impurities will be sufficient to make the process inoperative by changing the decomposition voltage too much. Although this interfered seriously with commercial operation in the beginning, the effect of all the possible impurities and the amounts of each that are permissible now is known, and proper control can be maintained.

Electrolysis is carried out either in lead-lined wooden tanks or in concrete tanks lined with a sulfur-sand or rubber mixture. About 150 cells are connected in the circuit which draws 8000 amp direct current.

Cathodes are aluminum plates  $\frac{1}{8} - \frac{3}{32}$  in. thick, and have an area of 12 sq ft, of which about 75% is submerged.

Anodes are cast refined-lead sheets about  $\frac{1}{4}$  in. thick with an area of 9–10 sq ft, of which about 84% is submerged. They have a life of better than 3 yr.

The solution is circulated at a rate of about 10 gal per min per cell, passing through special cooling cells at various stages to keep its temperature about 100 F (35 C).

In the *low current-density process*, using 10% sulfuric acid in the solution, the current density usually is maintained at about 25–30 amp per sq ft; and, under these conditions, 1 ton of zinc will require about 3550 kwhr. Cathodes usually are withdrawn at the end of 24 hr, although times as long as 48 or 96 hr are not uncommon. The longer times tend to result in much rougher deposits.

## THE TANTON HIGH CURRENT-DENSITY PROCESS

Some improvement in zinc deposition can be effected by the use of a solution containing 22–27% sulfuric acid and current densities of about

<sup>7</sup> See, for example, W. C. Snow, *Trans. A.I.M.E.*, **121**, 1936, 482–526.

100 amp per sq ft. This so-called Tainton process<sup>8</sup> gives better purification, produces three times as much zinc per unit of cathode area, and is more compact than the low current-density process. It has the disadvantages that the solutions must be run hotter and that the stronger acid has a greater corrosive effect which also is increased by the higher temperature of operation.

#### REMELTING

In all the electrolytic zinc processes, the cathodes are remelted in fuel-fired reverberatory furnaces, holding about 100 tons, for casting into commercial slabs weighing about 50 lb each.

#### COMMERCIAL GRADES OF ZINC

Slab zinc (spelter) is graded, according to its impurity content, into six classifications. These are described fully in A.S.T.M. Standard B6, some of the information in which is listed in Table XII.

TABLE XII A.S.T.M. CLASSIFICATION OF SLAB ZINC

GRADE	% PB*	% FE*	% CD*	SUM* OF PB, FE, CD	% ZINC (MIN)	RELATIVE TONNAGE PRODUCED
Special high grade	0.006	0.005	0.004	0.010	—	—
High grade	0.07	0.02	0.07	0.10	99.5–99.8	30% of total
Intermediate	0.20	0.03	0.50	0.50	99.35	12% “ “
Brass special	0.60	0.03	0.50	1.0	98.7	15% “ “
Selected	0.80	0.04	0.75	1.25	—	—
Prime western	1.60	0.08	—	—	98.0	43% “ “

\* Max. “None” specified for aluminum in all but prime western.

The *special high grade* and the *selected* types usually are not marketed commercially. *High grade* zinc normally commands a premium of about ½ cent per pound over the *prime western* grade, with the premium for the other grades of intermediate purity running somewhat lower. The grade of metal selected will depend upon the intended application since some of the impurities may be more, or less, harmful than others.

<sup>8</sup> See, for example, W. G. Woolf and E. R. Crutcher, *Trans. A.I.M.E.*, **121**, 1936, 527–539.



*For Further Study Refer to*

1. *Non-Ferrous Production Metallurgy*, by John L. Bray: John Wiley & Sons, Inc., New York, 1941.
2. *An Outline of Metallurgical Practice*, 2d ed., by Carle R. Hayward: D. Van Nostrand Company, Inc., New York, 1940.
3. *The Mineral Industry*, Edited by G. A. Roush: McGraw-Hill Book Company, Inc., New York (published annually).
4. *Minerals Yearbook*: U.S. Dept. of the Interior, Bureau of Mines (published annually).
5. *Handbook of Non-Ferrous Metallurgy*, 2d ed., Edited by Donald M. Liddell: McGraw-Hill Book Company, Inc., New York, 1945.
6. *Metallurgy of Lead and Zinc*, Rocky Mountain Fund Volume: Trans. A.I.M.E., **121**, 1936, 339-737.
7. *Magnesium Metal*, by W. W. Moss: The Williams and Wilkins Company, Baltimore, Md., 1942.
8. *The Technology of Magnesium and Its Alloys*: F. A. Hughes & Co., Ltd., London, 1940.
9. "Enlarging Magnesium Output a Hundred Fold," by Philip D. Wilson, *Mining and Metallurgy*, **23**, 1942, 201-204; *Metal Progress*, **41**, 1942, 339-341.
10. "How Europe Produces Its Magnesium," *Chem. & Met. Eng.*, **48**, January 1941, 78-81.
11. "Magnesium from the Sea," by S. D. Kirkpatrick, *Chem. & Met. Eng.*, **48**, November 1941, 76-84.
12. "Magnesium by the Hansgiring Process," by S. D. Kirkpatrick, *Chem. & Met. Eng.*, **48**, September 1941, 91-94.
13. "Magnesium Production at the World's Largest Plant," by R. H. Ramsey, *Chem. & Met. Eng.*, **50**, October 1943, 98-101, 115; *Eng. & Min. Journ.*, October 1943, 61-67.
14. *Magnesium*: American Society for Metals, Cleveland, Ohio, 1946.
15. *Transactions Amer. Inst. of Mining and Metallurgical Engs.*, Non-Ferrous Metallurgy Division: A.I.M.E., New York (published annually).
16. *An Outline of Aluminum*: Aluminum Company of America, Pittsburgh, Pa., 1940.
17. *The Aluminum Industry*, by J. D. Edwards, F. C. Frary, and Zay Jeffries: McGraw-Hill Book Company, Inc., New York, 1930.

## The Production of Pig Iron and Cast Iron

### IRON ORES

THERE ARE ONLY FOUR IRON ORES<sup>1</sup> USED TO ANY EXTENT today in this country. The first and most important of these, *hematite* or *red ore*, corresponds to the chemical formula,  $\text{Fe}_2\text{O}_3$ , and when pure contains about 70% iron by weight. Commercial ores of this type, in use at the present time in this country, average about 51% iron, although some are much poorer. The hematites comprise more than 90% of the ores mined in this country today. The most extensive deposits in the United States are those in Minnesota, Wisconsin, and Michigan in the Lake Superior region, which produced 85% of the ore mined in 1940; and those in the vicinity of Birmingham, Alabama, which produced 9%. Tremendous amounts of lower grade ores are available in deposits scattered throughout the country. Sometime in the future, no doubt, these will be worked with profit, although the ores probably will have to be concentrated to be of much value under present reduction practice.

The second important class of iron ores is the *brown hydrated iron oxides*, corresponding to the general formula,  $m\text{Fe}_2\text{O}_3 \cdot n\text{H}_2\text{O}$ , and containing about 52–61% iron in the pure state. The commonest example is known as *limonite* or *bog iron ore*,  $2\text{Fe}_2\text{O}_3 \cdot 3\text{H}_2\text{O}$ . These ores are not so rich as the hematite ores, the commercial brown ores in this country generally containing appreciably less than 50% iron. Consequently, the brown iron ores comprise only a little more than 1% of the ore used at this time in the United States, although they are used more extensively in other parts of the world.

The third ore, *magnetite* or *black ore*,  $\text{Fe}_3\text{O}_4$ , has been known for thousands of years, and frequently is referred to as *lodestone* because of its high density and ferromagnetic characteristics. When pure, it contains

<sup>1</sup> See the *Minerals Yearbook*, U.S. Dept. of Interior, Bureau of Mines, 1941 (Review of 1940), 529–547.

about 75% iron; and the commercial ores, although relatively scarce, contain about 63% iron. The magnetite ores can be concentrated readily by magnetic methods. Most of the magnetite used today is mined near Cornwall, Pennsylvania, Port Henry, New York, and in northern New Jersey. It is a valuable iron ore; but deposits of it are relatively infrequent, comprising only about 5% of the country's supply.

The fourth ore, *siderite*,  $\text{FeCO}_3$ , is used frequently in other countries, but is of little importance here because of our tremendous reserves of the richer hematite, nearly  $1\frac{1}{2}$  billion tons in known deposits in Michigan and Minnesota alone. Usually, part of the iron in siderite has been replaced with calcium or magnesium forming the so-called spathic or kidney ores. Siderite usually is calcined to drive off its  $\text{CO}_2$  before using. Frequently it will contain sufficient lime to be self-fluxing.

If these more valuable ores should become exhausted, we still have available tremendous deposits of the *iron silicates* and of *pyrites*,  $\text{FeS}_2$ , more frequently referred to as *fool's gold*, because of its color. Sulfur is the most serious of the impurities in iron; and, consequently, before these pyritic ores can be used they must be roasted or heated in air to remove as much of it as possible. This makes pyrites of little importance on a tonnage basis at the present time because of the expense involved, but future needs or developments may modify this picture drastically. Even now a process, which shows exceptional promise, is under development for preparing iron powder from this material.<sup>2</sup>

#### IMPURITIES IN IRON ORES

The impurities commonly found in iron ores can be classified into one of three groups depending upon their chemical reactivity in the reduction process:

1. The impurities that never are reduced in the blast furnace, and hence do not affect the composition of the iron. These are compounds of the chemically active elements such as alumina,  $\text{Al}_2\text{O}_3$ , lime,  $\text{CaO}$ , magnesia,  $\text{MgO}$ , soda,  $\text{Na}_2\text{O}$ , potassia,  $\text{K}_2\text{O}$ , and the oxides of the other alkali and alkaline earth elements.
2. The impurities that may be reduced partially in the blast furnace, forming elements that will alloy with the iron. These include silica; the silicates, sulfates, and selenates; titania,  $\text{TiO}_2$ ; and various compounds of manganese, chromium, vanadium, cobalt, columbium, zirconium, and certain of the rarer elements.

<sup>2</sup> Private communication from John Wulff.

3. The impurities that always are completely reduced in the blast furnace, and alloy with the iron. These include all the compounds of arsenic and phosphorus, both harmful elements in most iron alloys. Arsenic compounds, fortunately, are not common in iron ores.

#### REDUCTION OF IRON ORE

Almost all of the world's supply of iron first is reduced in the iron blast furnace to an impure form called *pig iron*.<sup>3</sup>

The only notable exception is the so-called Swedish sponge iron which is made by the Sieurin process. In this process, ore concentrates of high purity, coal, and lime are charged in layers into covered crucibles. They then are heated in kilns until reduction is complete. After cooling, the iron produced is removed, either in the form of a round porous cake about 10 in. in diameter and 2–2½ in. thick, or in the form of a coarse powder. Swedish sponge iron, which is the purest obtainable commercially for making certain special grades of steel, usually contains about 93% metallic iron and 4% iron oxide (FeO), with the remainder essentially all gangue consisting mostly of silica (SiO<sub>2</sub>) with small amounts of V<sub>2</sub>O<sub>5</sub> and about 0.03% carbon. The normal impurities will average about 0.013% phosphorus, 0.025% sulfur, and 0.025% manganese, all combined with the iron. Special grades of this material may contain up to about 99.5% iron. The process is only successful because of the particular conditions, both economical and metallurgical, which exist in Sweden.

No other methods of direct reduction ever have proved to be practical although millions of dollars have been spent in their development.<sup>4</sup>

Into the top of an average blast furnace each day is poured about 1100 tons of ore; 250 tons of limestone flux; and 600 tons of coke; while simultaneously into the bottom is blown, under a pressure of about 15 psi, about 75,000 cu ft of air per min, which has been preheated to a temperature higher than 1000 F (540 C).

From this tremendous mass of material is produced each day about 700 tons<sup>5</sup> of pig iron, and about 380 tons of slag.

The analyses of typical examples of these products are given in Table XIII although the actual analysis of the metal and slag in any heat will depend on so many different factors that wide variations are possible.

<sup>3</sup> See, for an excellent account of American practice, W. A. Haven, *Journ. Iron & Steel Inst. (Brit.)*, **141**, 1940, 405–458.

<sup>4</sup> See, for example, *Engineer*, **174**, No. 29, 1942, 417; *Fortune*, **27**, Jan., 1943, 44.

<sup>5</sup> Many blast furnaces can, and are, producing 1400 tons or more of pig iron each day.

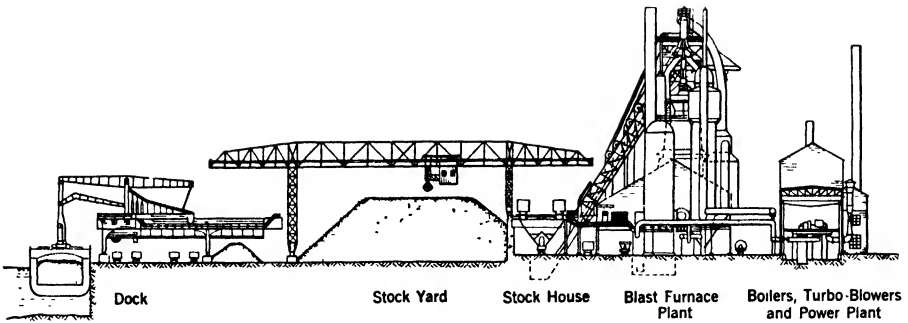


FIGURE 105. Elevation of a typical blast furnace plant located on a water front. (Courtesy W. A. Haven, Arthur G. McKee & Company.)

TABLE XIII CHEMICAL ANALYSES OF SOME TYPICAL PIG IRONS

"FOUNDRY" PIG IRON	"BESSEMER" PIG IRON	"BASIC" PIG IRON	SLAG (FROM FURNACE MAKING "BASIC" PIG IRON)
Rem. Fe	Rem. Fe	Rem. Fe	35% SiO <sub>2</sub>
3.0 -4.5% C	4.15-4.40% C	4.10-4.40% C	15% Al <sub>2</sub> O <sub>3</sub>
1 - 4% Si	1.0 -2.25% Si	1.5 (max) % Si	44% CaO
0.2 -1.5% Mn	0.5 -1.00% Mn	0.4 -2.0 % Mn	2.7% MgO
0.10-2.0% P	0.04-0.10% P	0.11-0.30% P	1.1% MnO
0.04-1.0% S	0.045 (max) % S	0.05 (max) % S	1.2% FeO
			1.4% S

The gases removed from a furnace each day have sufficient heating value remaining in them to preheat and blow all the air used; to furnish, in some installations, all the electricity used in the plants when they are burned in gas engines; or to fill an appreciable portion of the fuel requirements of the furnaces and soaking pits. However, some enrichment in calorific power usually is required for at least some of these purposes.

In a day nearly 8,000,000 gal of cooling water are used, sufficient to supply a town of 100,000 people in the United States.

It can be comprehended readily that a single blast furnace, which may run throughout a campaign of as much as five years without shutdown and produce more than 1,000,000 tons of pig iron, entails a good-sized operation in itself.

There are three essential features to a *blast furnace plant* (Fig. 105):

1. The *furnace*.

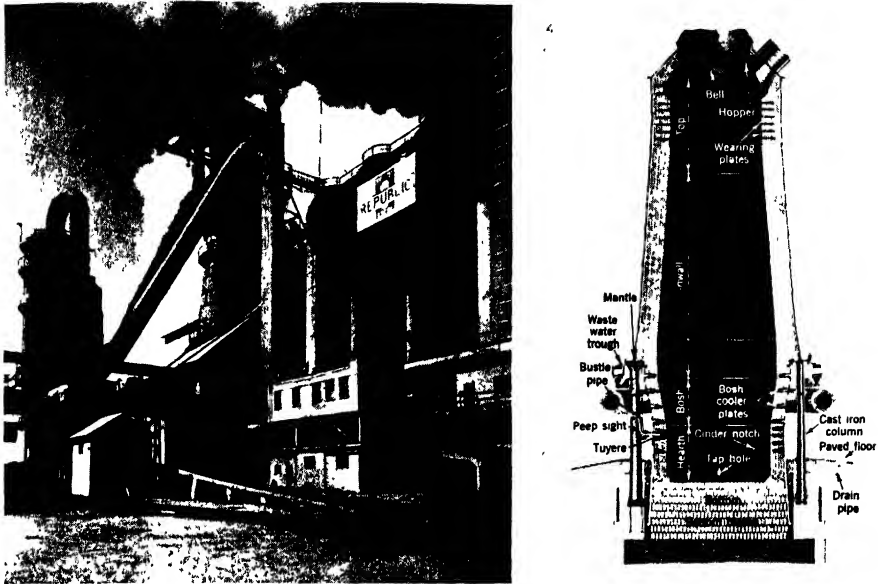


FIGURE 106. Typical modern blast furnace. *a.* (Left) External view. (Courtesy Republic Steel Co.) *b.* (Right) Cross section. (From *Modern Refractory Practice*, courtesy Harbison-Walker Refractories Company.)

2. The *air and gas plant*, which includes the stoves for preheating the air and the blowing engines.
3. The *pig and slag plant*.

#### THE IRON BLAST FURNACE

As a structure, the iron blast furnace (Figs. 106 and 107) consists of three main parts: (*a*) the *hearth*; (*b*) the *bosh*; (*c*) the *stack*.

The hearth or crucible is nearly always about 18–25 ft in diameter and 10–12 ft deep with a slight basin shape. Its size determines the tapping interval. The pig iron is tapped from the bottom of the hearth, at the tapping hole or *iron notch*; and the slag from the *cinder notch*, which is usually about 4–5 ft above the iron notch and 45–90 deg removed from it. Usually iron is tapped every 4–5 hr; and slag every 2–3 hr or as frequently as it becomes necessary. The *tuyeres*, 10–16 in number, with an internal diameter of 4–7 in., are placed around the periphery of, and at the top of, the hearth. Through them, the preheated air enters the furnace from the bustle pipe, so they are, of necessity, water cooled. Much of what actually is known about the reactions inside of full-size blast furnaces has been learned by observations through the sight holes in these tuyeres. The posi-

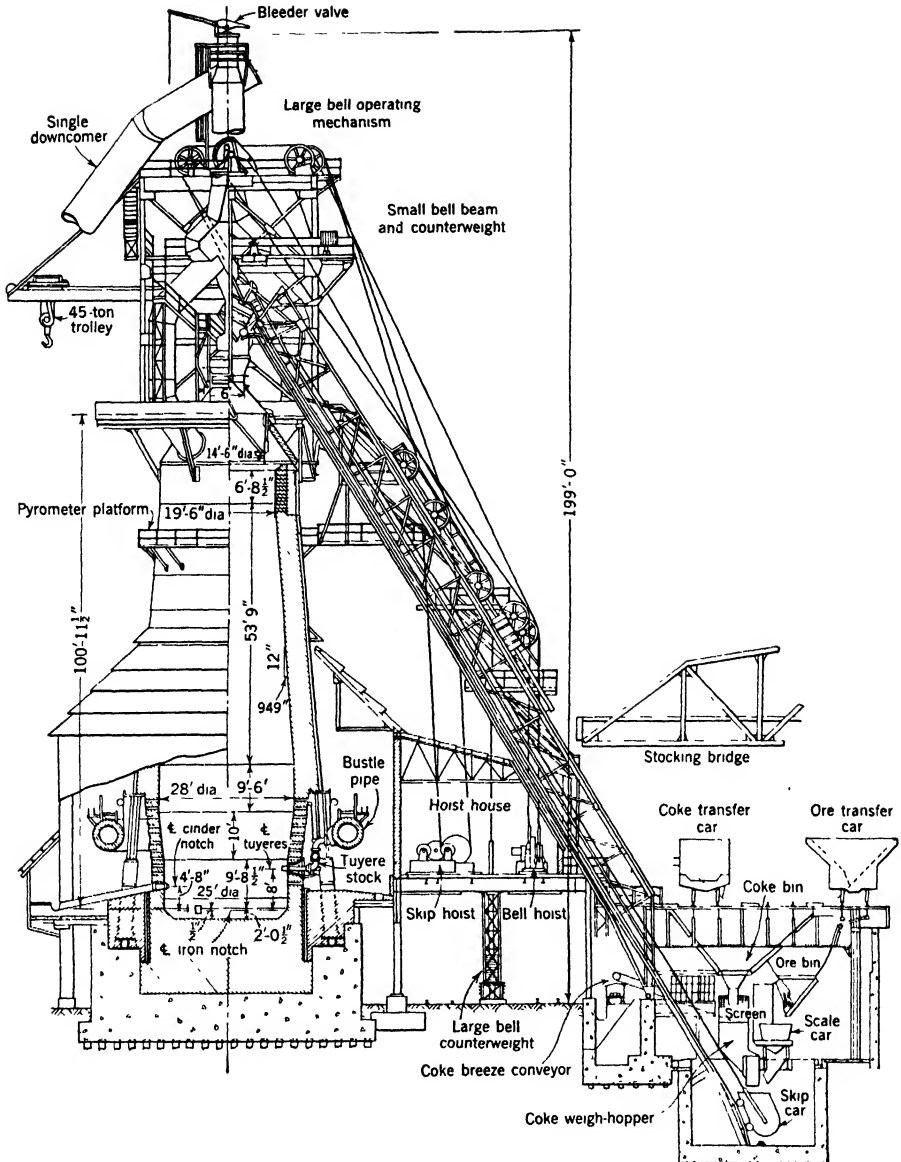


FIGURE 107. Diagrammatic cross section through a 1000-ton blast furnace. (Courtesy W. A. Haven, Arthur G. McKee & Company.)

tion of the tuyeres determines also the height to which the slag can rise above the cinder notch.

The bosh of the furnace lies just above the hearth. It has the form of an inverted frustrum of a cone 9–12 ft high. The smaller end of the bosh tops the crucible, and the larger end comprises the section of greatest diameter

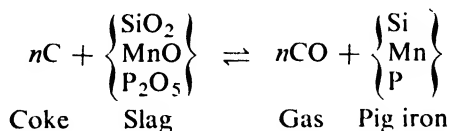
of the furnace. It is in the bosh, just above the tuyere line, that the highest temperature in the furnace is attained.

Placed above the bosh, in an upright position with a height of 70–100 ft, is the stack or shaft. The *inwall section* of the stack tapers from the bosh diameter of 28 ft at the bottom to 18–22 ft in the nearly straight *top section*. It is topped by the gas offtakes, and by the double bell and hoppers used for distributing the charge within the furnace without loss of gas.

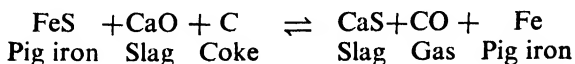
#### REACTIONS IN THE IRON BLAST FURNACE

The fundamental reactions in the blast furnace are illustrated in Fig. 108. Probably better than 85% of the coke in the charge burns to CO at the tuyere zone. The temperature produced by this combustion is of the order of 3360 F (1850 C), so it can be seen easily, in the light of the earlier discussion on the CO–CO<sub>2</sub> equilibria with temperature, that practically nothing but CO results from the burning. This gas, along with the nitrogen in the air which serves only as a carrier of heat and does not react chemically, rises through the furnace in about 5 sec under full blast as compared with the time of about 8–14 hr required for the solid charge to descend through it. Because of the high temperature of these gases, most of the solid material, with the exception of the coke, tends to melt in about the lowest 20 ft of the furnace. After rising about 40 ft, the temperature of the gases has fallen to about 1850 F (1000 C), and CO<sub>2</sub> can exist. CO, consequently, can begin to act as a reducing agent.

In the smelting (lower) portion of the bosh two things tend to occur, one physical and one chemical: (a) the volume of the charge decreases rapidly as it melts; and (b) reduction by carbon alone takes place. Because of the high temperature, the carbon reduces certain of the oxides present, thereby increasing the impurity content of the metal, according to the general reaction:



In addition, the high temperature will assist the reaction between the iron sulfide, dissolved in the molten iron, and any excess lime in the slag to form calcium sulfide, thus removing sulfur from the molten iron, and putting it into the slag, according to the reaction:





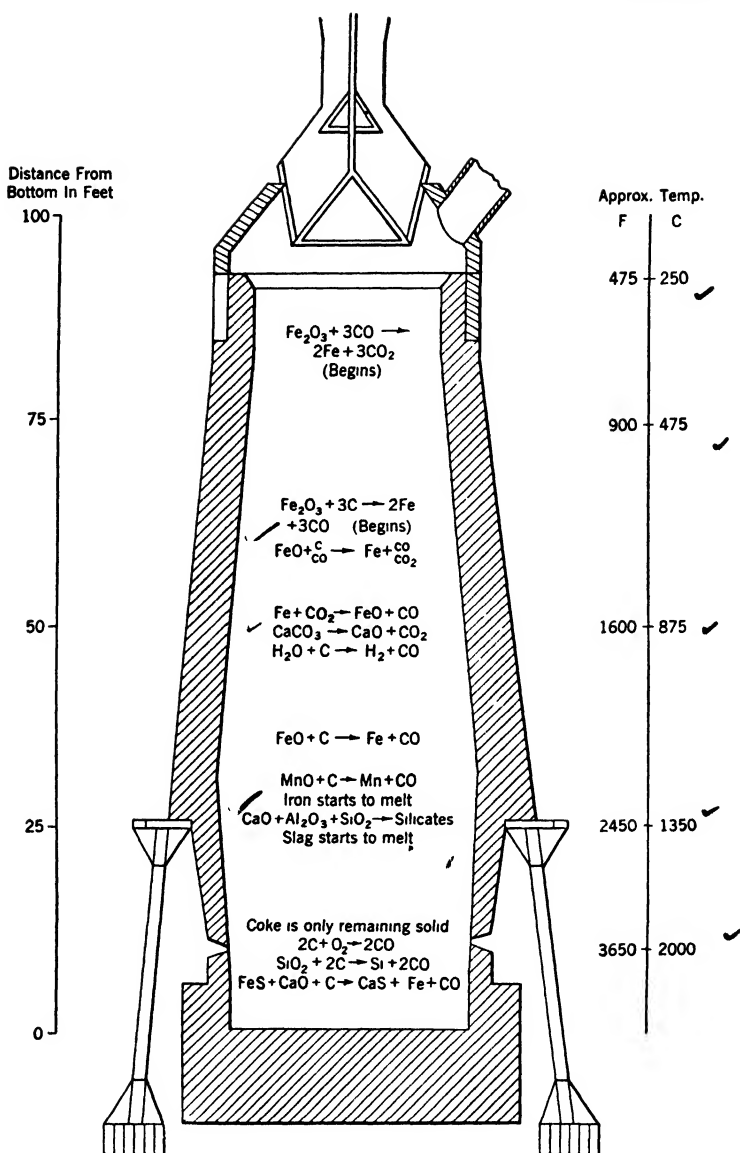
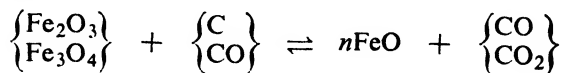


FIGURE 108. The fundamental reactions in the blast furnace shown in relationship to the sections of the furnace in which they are believed to occur.

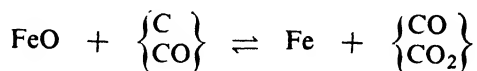
The region in which rapid melting occurs determines the height of the bosh, which will, therefore, be about 20 ft. The diameter of the bosh at the top is determined by the diameter of the bottom of the stack, and this, in turn, by the amount the charge swells as it descends through the stack.

The CO in the gases rising through the stack will continue to act as a reducing agent for the oxides of iron until its temperature drops to about

1000–1100 F (540–590 C). However, because of the lower temperature, only those oxides whose chemical activity is similar to or less than iron will be affected. It may be considered, for simplicity's sake, that the first reduction is always to FeO:

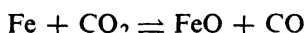


and that this then is reduced to metallic (sponge) iron



Although these equations are probably much too simple, they give a sufficiently accurate idea of what is occurring. The CO gas certainly will be a more important reducing agent than carbon in this region because of the much more intimate contact between it and the surface of the ore where the reduction must occur. Although the gas is in contact with this surface for a much shorter period of time than the solid carbon, it is being renewed constantly by a fresh supply arising from below.

Unfortunately, some of this reduction is nullified by the counterreaction:



which will occur to some extent, especially at lower temperatures.

By the time the gas has reached a point roughly 10 ft below the top of the stack, its temperature has fallen to about 600 F (310 C), and about the only reactions that occur are those relating to the drying and preheating of the charge.

Throughout nearly the entire stack, the rising gas will be enriched in CO<sub>2</sub> because of the calcining of the limestone which normally takes place in the range 1475–1825 F (800–1000 C). As pointed out in Chap. III, this will affect the reactions which occur, by changing the CO:CO<sub>2</sub> ratio.

#### IMPURITIES IN THE BLAST FURNACE

All commercial iron contains varying amounts of the five impurities, *carbon, silicon, manganese, phosphorus, and sulfur*. The last two are the most harmful although even these, if properly used, impart properties which are advantageous for certain applications. All of these impurities are found in pig iron, and their control is important.

**CARBON** Carbon is the most important element in pig iron because it gives an opportunity for controlling physical properties, and, in steel-

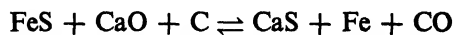
making, serves as a fuel. The carbon content of the pig is determined almost entirely by the solubility of carbon in the impure liquid iron at the temperature of smelting. This solubility usually ranges from 4.00–4.25% carbon, but may vary appreciably, depending on the other impurities present and the operating temperature of the furnace.

**MANGANESE** Any manganese present comes in with the ore as an oxide, and passes through the furnace essentially unchanged. Its reduction to manganese by carbon occurs in the smelting zone as noted previously, about 50–75% of the total amount of manganese charged being found in the pig iron.

**PHOSPHORUS** In the presence of excess carbon or iron, either phosphorus pentoxide,  $P_2O_5$ , or the calcium phosphates, such as  $3CaO \cdot P_2O_5$ , will be reduced to phosphorus, especially at the high temperature of the smelting zone. This is the only element that *cannot be controlled* in the blast furnace in any way. Any phosphorus in the ore will pass directly through the furnace and enter the pig iron.) In the past, this led to a rough classification of iron ores, on the basis of their phosphorus content, into *Bessemer ores*, which contained less than 1000 times as much iron as phosphorus, i.e., less than 0.1% phosphorus, and *non-Bessemer* or *basic ores*, which contained more phosphorus than this amount. This classification was used widely in the earlier part of the century when the Bessemer process was of major importance and Bessemer ores commanded a good premium. However, under present-day conditions, much less of the available ore is of Bessemer grade, and so much steel is made by the basic open-hearth process, in which phosphorus can be removed, that the classification means much less, although it still is used and the premium rating for Bessemer ores still remains in effect.

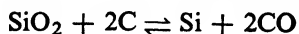
**SILICON AND SULFUR** The percentages of the final two impurities are somewhat interdependent. Conditions in the smelting which tend to remove one will increase the other, and vice versa, so that the saying has arisen “high sulfur, low silicon—low sulfur, high silicon.”

Sulfur nearly always will be found in the smelting zone as an iron sulfide,  $FeS$ , which is soluble in molten iron. It enters the furnace both in the ore and in the coke so it can be minimized by controlling their purity. In the presence of excess carbon or silicon and  $CaO$ , i.e., reducing conditions and a basic slag, the sulfur can be removed to the slag according to the reaction:



which never will go to completion for other reasons. Because  $CaO$  is a strong oxide, the reaction will take place only at high temperatures, of the order of 3400 F (1850 C) or higher.

On the other hand, at temperatures above about 2750 F (1500 C), carbon will reduce  $\text{SiO}_2$ , and put silicon into the pig iron according to the reaction:



The manganese and carbon contents of the pig iron also will increase at the same time under these conditions. Consequently, a "hot" furnace hearth will tend to produce a pig iron containing high silicon and low sulfur. The product of this treatment is sometimes called *hot iron*.

If the furnace hearth is run at lower temperatures, on the other hand, neither of these reactions will occur to any extent. Therefore, a "cold" furnace hearth will tend to give a pig iron containing comparatively low silicon and high sulfur or *cold iron*.

The removal of sulfur in the slag is affected markedly by the exact composition of the slag used, the basicity being especially important. Some slag compositions are much better for this purpose than others, even at low temperatures. Specific examples necessarily would depend upon the particular type of iron ore being utilized.

Methods have been developed for controlling sulfur by the addition of various chemical compounds to the molten pig iron after it has been tapped from the furnace.<sup>6</sup> These methods are much more widely used in European practice than in American today. With the advent of high sulfur ores, they will undoubtedly be used to a much greater extent but probably in a greatly improved form.

#### TEMPERATURE CONTROL IN THE IRON BLAST FURNACE

In theory, the blast-furnace operator can control the hearth temperature by changing any of three factors: (a) the amount of coke or *coke burden*; (b) the composition of the slag; (c) the temperature and volume of the blast. The first two have an obvious disadvantage because of the time required for the charge to pass down through the furnace and influence the temperature in the melting zone. The need for higher temperatures must be foreseen well in advance if either of them is to be used. On the other hand, the use of a greater volume of blast puts into the furnace more nitrogen, a gas which serves no useful purpose except as a carrier of heat. Nevertheless, for rapid heat only the third method can be used and it is not too efficient unless oxygen enrichment of the blast also is used.

Usually the operator can tell from his ores when higher temperatures will be needed and can plan his charge accordingly. Under these conditions, the three methods are somewhat interdependent. Less coke with a higher

<sup>6</sup>See, for example, G. S. Evans, *Steel*, 110, 1942, 82-88, 111-115.

blast temperature will give the same amount of heat as more coke with a lower blast temperature. The actual control generally falls on the slag, which acts as a carrier of heat, and is usually at a temperature somewhat higher than that of the pig iron. If it is viscous, it will absorb more heat, drip more slowly through the smelting zone, and thus tend to give a higher temperature in this region than would be produced by a fluid slag dripping rapidly through it. The composition of the slag, therefore, must be controlled carefully so that it may remove as much sulfur as possible at the most efficient temperature of operation without requiring excessive fuel.

Precise temperature control is almost impossible because the pig iron, in order to be cast, should not be below 2500 F (1370 C) or above 2800 F (1540 C), thus giving a total working range of only 300° F. The use of lower temperatures results in too great a loss of fluidity whereas higher temperatures lead to excessive gas absorption by the molten metal, although this may not be too important in many instances.

#### THE FURNACE GASES

To control the furnace gases, an elaborate system has been built up. After rising to the top of the furnace, the gas is piped off, and usually passed through various devices to clean it, sometimes to less than 0.02 grains of solid material per cubic foot. About 20% of it then goes to pre-heat the hot stoves; 10–20% to actuate the blowing engines, depending on the type used; and the balance, usually after some enrichment, serves as a fuel for coke ovens, steelmaking furnaces, soaking pits, or in gas engines used to generate electrical power.

As a rule, three or four *hot stoves* are available for preheating the air. These are, as illustrated in Fig. 109, about 100 ft high and 22 ft in diameter. They average about 7 sq ft of heating surface and 1.8 cu ft of refractory brick volume per cubic foot of wind blown per minute. They may be either center- or side-combustion stoves. During the usual cycle, the stoves are preheated by the combustion of the cleaned gases for 3 hr, and then are cooled, by the passage of cold air through them in a direction opposite to the path of the flame during the heating cycle, for 1 hr. The cold air will be preheated, of course, during this cooling process. With this system, one stove at a time is used for heating the blast and the stoves are changed once each hour. By alternating the gas and air flow at the proper intervals, which can be determined automatically by ordinary temperature-control equipment, the air supplied to the blast furnace can be maintained within reasonably close temperature limits. This method of preheating by the use of alternate countercurrent heating and cooling cycles is known as the

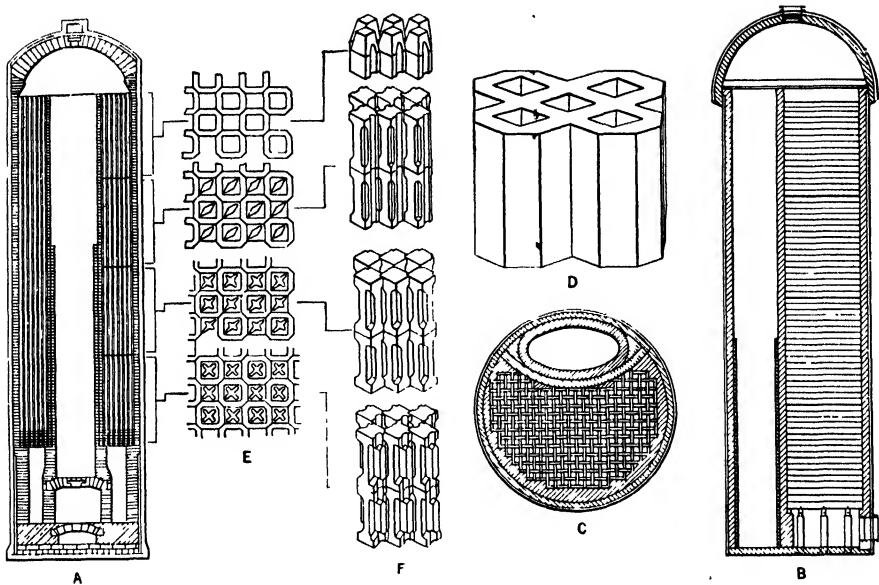


FIGURE 109. Blast furnace stoves, linings, and checkers, 1936 standard types. A. Longitudinal section, two-pass center-combustion type. B. Longitudinal section, two-pass side-combustion type. C. Cross section, two-pass side-combustion type, showing lining of ordinary checker type commonly used prior to 1930. D. Perspective of multihole-type checker proposed in 1932. E. Cross section of stove-lining filler-type tile checkers, proposed construction for 1937. F. Perspective of improved type open-joint checkers proposed in 1934. (From *The Making, Shaping, and Treating of Steel*, by permission of Carnegie-Illinois Steel Corporation.)

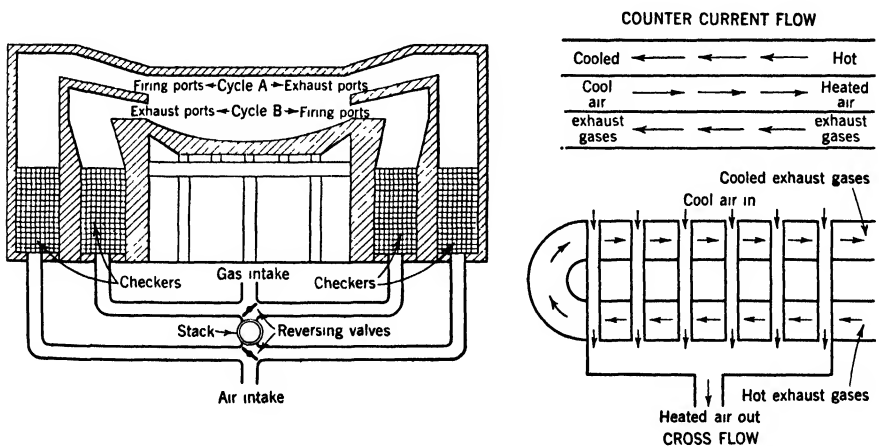


FIGURE 110. Two methods for preheating air and gas before combustion in a fuel-fired furnace. (Left) Regenerative or alternate flow system. (Right) Recuperative or continuous flow system.

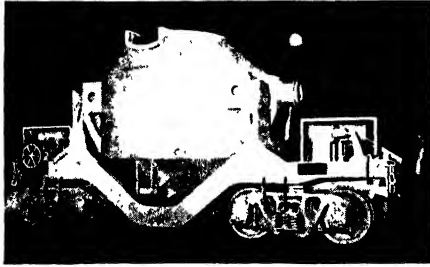


FIGURE 111. (Left) Hot metal car, 125-ton mixer-type. (Courtesy Wm. B. Pollock Company.)

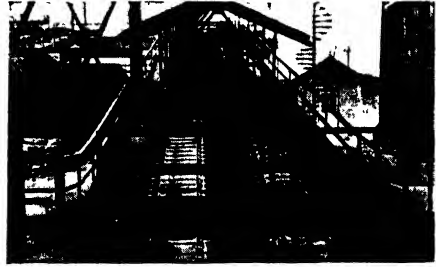


FIGURE 112. (Right) Uehling pig-casting machine of the double-strand type. (Courtesy Heyl & Patterson, Inc.)

*regenerative* system. It should not be confused with the somewhat less efficient *recuperative* system, in which the flow may be parallel-, cross-, or counter-current, but is continuous rather than alternate (Fig. 110).

#### PIG IRON

The pig iron tapped from the iron blast furnace used to be cast into small cakes on a large sand casting floor. Because of the manner of casting, the shape of these cakes, with the runners which fed them, resembled somewhat a litter of pigs suckling on a sow. The cakes consequently were called *pigs* and the product *pig iron*.

In modern practice the liquid pig iron either is taken directly to the steel-refining furnaces in huge mixing ladles (Fig. 111) which can keep 100 tons or more of molten metal hot for several hours without using external fuel, or else cast on a pig casting machine into standard sized pigs, weighing 50–150 lb. These machines (Fig. 112), working automatically and using water sprays to accelerate the cooling, replace many men in work which was extremely arduous. Pig iron used in the foundry for making castings of various kinds is sold as *foundry pig iron*, a typical analysis of which has been given previously. This is covered by A.S.T.M. Tentative Standard A43-T which limits the permissible variations from specified percentage compositions for 284 different grades.

#### SLAG

The blast furnace slag, which is tapped much more frequently than the pig iron, was discarded until recent years. After proper treatment, however, it can be crushed for use as railroad ballast, road-building material, or concrete aggregate; it can be granulated, by pouring molten into flowing

water, for use in making Portland cement; or it can be blown with air or steam to make quite a satisfactory insulating material.

### CAST IRON

Pig iron itself is used infrequently for castings in the form just as it comes from the blast furnace. Not only is its composition apt to be unsuitable, but it is not particularly uniform. Both of these factors require very experienced casting technique to overcome, and even then are likely to give an inferior product. However, by tapping into a large mixing ladle, using rapid analytical methods, and mixing partially refined iron with the raw liquid pig, sufficient improvement can be secured to make the metal satisfactory for some applications. This would be, naturally, a comparatively low-cost product, but the mechanical properties probably would also be poor.

The partially purified pig irons are called *cast irons* because their properties are such that they cannot be worked satisfactorily, and hence must be cast while liquid directly into what is essentially their final shapes. In all of these materials, the carbon is present, usually in amounts ranging from 2–4%, either as flake graphite or as a hard, brittle compound with iron, having the formula  $\text{Fe}_3\text{C}$  and known as *cementite*, iron carbide, or simply as combined carbon. The properties, and the type of solid cast iron produced, are determined largely by which of these forms predominates. Control over this is secured by varying the chemical composition and the rate of cooling. The section thickness in any given casting obviously would affect this latter factor. The primary cast irons, i.e., those used chiefly “as cast,” are known as *gray* and *white cast iron*.

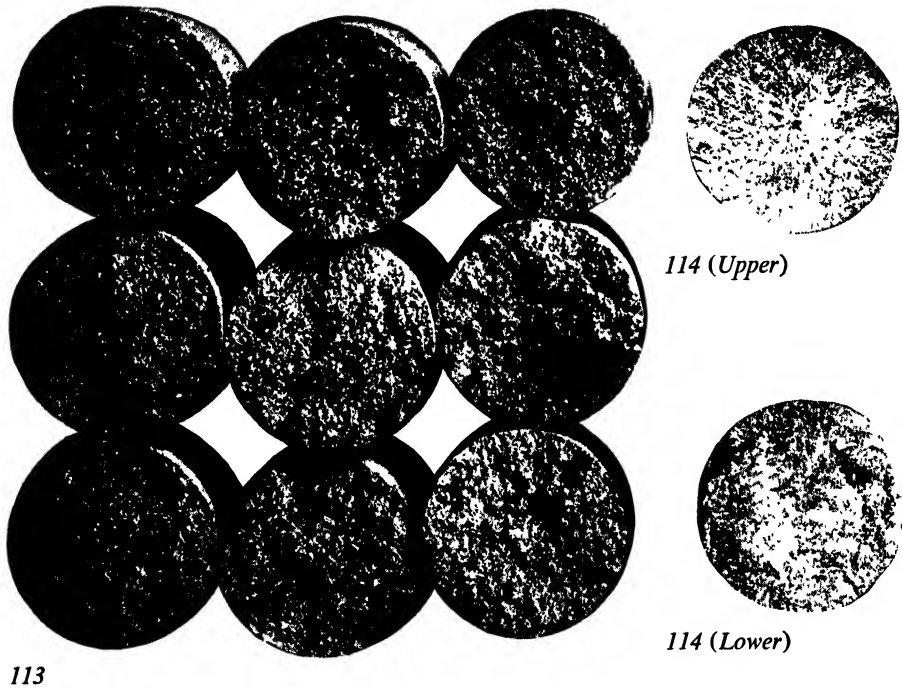
Definitions of terms relating to cast iron are covered by A.S.T.M. Tentative Standard A196-T which should be referred to in case of doubt or discussion.

### GRAY IRON

If the majority of the carbon in the iron is in the form of the relatively soft and weak graphite, with less than 0.8% carbon in the combined form, the material is termed gray cast iron. It derives its name from the fact that, when fractured, the break tends to occur through the weakest sections, viz., the graphite flakes, thus exposing a surface which is dull gray in color (Fig. 113).

The separation of the carbon in this form during solidification is favored, in general, by a high silicon content, varying from 1½–3% depending on the section thickness, and by a slow rate of cooling. The thinner the





113

FIGURE 113. Fractures typical of gray cast irons showing how increased carbon content coarsens and darkens the fracture. The carbon contents increase as position in the group changes from lower right to upper left. (Photograph courtesy The International Nickel Company, Inc.)

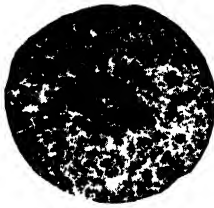
FIGURE 114. Fractures typical of Ni-Hard-type white cast iron containing 3.5% C — 5% Si — 4.5% Ni — 1.5% Cr — rem. Fe. (*Upper*) Sand cast. (*Lower*) Chill cast. (Specimens courtesy The International Nickel Company, Inc.)

section is, the higher will be the silicon content required to produce a given structure, because thinner sections cool more rapidly than thicker ones. The mechanical properties, as will be discussed in more detail later, will be affected markedly by the size, shape, and distribution of the graphite flakes.

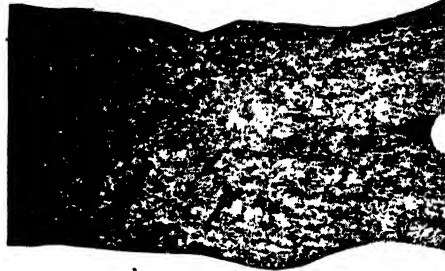
#### WHITE IRON

If practically all of the carbon occurs in the combined form as the hard brittle iron carbide, the fracture will tend to occur through this material because of its brittleness, and the surface thus exposed will have a silvery white metallic luster (Fig. 114). The material is termed white cast iron, because of this fact.

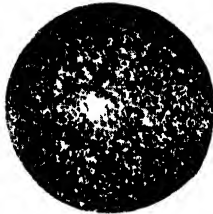
The separation of carbon as iron carbide on solidification is favored by a low silicon content, and by rapid cooling. It is possible, and, in fact, common, so to control the composition of the iron that a small section will



115 (Upper)



116 (Upper)



115 (Lower)



116 (Lower)

FIGURE 115. Fractures typical of mottled cast iron. (*Upper*) Normal type, a white iron turning gray, as shown by graphitic spots in the structure. (*Lower*) A carbidic iron containing 3.25% C — 2.5% Si — 1.2% Cr — rem. Fe, a gray iron turning white by forming a well-defined carbide network. (Specimens courtesy Albany Castings Co., and the International Nickel Company, Inc.)

FIGURE 116. Fractures typical of chill cast iron containing about 2.8% carbon, 2.3% silicon. (*Upper*) Uninoculated. (*Lower*) Inoculated. (Specimens courtesy The International Nickel Company, Inc.)

be completely white in fracture, whereas a somewhat larger one will be completely gray.

#### MOTTLED AND CHILL CAST IRON

Borderline castings, in which the structure and fracture show a mixture of gray iron and white iron because of proper balancing of the factors of chemical composition and rate of cooling, are termed mottled cast iron (Fig. 115). Frequently it is desirable to control specifically the structure and properties of the cast iron for a definite purpose, and to ensure a gray structure in one part and a white structure in another instead of the two being randomly mixed. This type of casting is known as a chill casting. As the name implies, its structure is determined by the already stated fact that, for a given chemical composition, a rapid cooling rate will tend to give a white structure, whereas a slow rate will tend to give a gray one. Consequently, a plate of metal, or some other material having a relatively high thermal conductivity, is built into the usual sand mold in order to cool rapidly or to *chill* the desired section. This section, therefore, will have

a white fracture and will blend, through a mottled zone, into a region which has a gray fracture, as illustrated in Fig. 116, because the rate of cooling was slower there.

#### SUPERHEATING AND INOCULATION

It has been shown repeatedly<sup>7</sup> that, when cast irons are melted at temperatures within the range 2725–3100 F (1500–1700 C), subsequent graphitization on cooling is inhibited to some extent. Because of this, graphitization does not commence until the iron has cooled to some temperature which is well below the solidification zone. In addition, there is a much shorter range within which graphitization can occur. Consequently, when the reaction does occur, the flakes tend to be finer and there is some carbide stabilization.

In American practice, most cupolas maintain a spout temperature of about 2750 F (1510 C) and only a few producing automotive castings run 2800 F (1540 C) or higher consistently. Superheating usually is accomplished in the electric furnace, either by direct melting or by duplexing the cupola iron.

When it is desired to improve the structure of the cast iron and, consequently, its mechanical properties, the metal often is inoculated just before pouring.<sup>8</sup>

Ferrosilicon, calcium silicide, graphite, and numerous commercial inoculants are used for this purpose. Inoculation and superheating constitute the principal reasons for most of the “trade-marked” cast irons. The effects of inoculation on the macrographic structure of a chill casting also are illustrated in Fig. 116. The other characteristics of these cast irons will be discussed in more detail in a later chapter.

#### THE STEP-BAR TEST FOR CAST IRONS

In order to determine the characteristics of a given composition of cast iron, the *step-bar test* sometimes is used. In this test, the iron is cast into a mold of metal having the shape shown in Fig. 117. Fracture of the various sections will determine rapidly the structure which can be expected from that iron for chill cast sections of various thicknesses. The test is particularly useful for many alloy cast irons.<sup>9</sup>

#### THE TRANSVERSE FLEXURE TEST FOR CAST IRON

Gray iron, in particular, usually is subjected to the transverse flexure test described in A.S.T.M. Standard A48. In this test a standard test bar

<sup>7</sup> See, for example, N. A. Ziegler and H. W. Northrup, *Trans. A.F.A.*, **47**, 1939, 620–652.

<sup>8</sup> This is well discussed by J. T. Eash, *Trans. A.F.A.*, **49**, 1941, 887–910.

<sup>9</sup> See, for example, P. D. Merica, *Trans. A.I.M.E.*, **125**, 1937, 13–46.

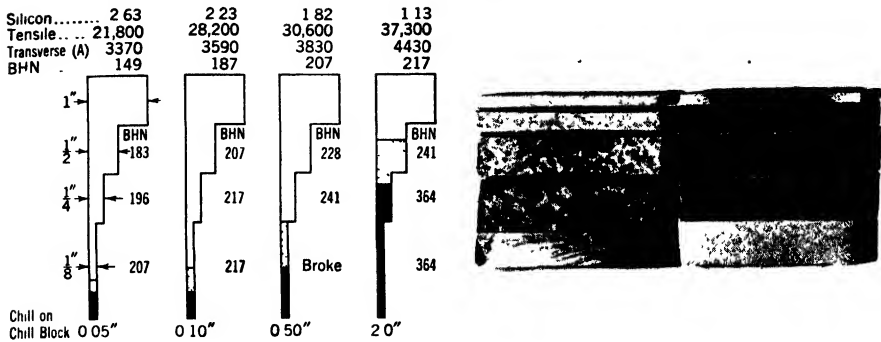


FIGURE 117a. (Left) Hardening gray iron by decreasing the silicon content as indicated by the step-bar test. b. (Right) A somewhat similar hardening effect is produced by adding nickel. This is illustrated by the fractures of 1/8-, 1/4-, 1/2-, and 1-in. thick sections of a step bar. The 1-in. thick section was sliced half way through by means of a high-speed rubber-bonded abrasive wheel before being fractured. Right, step bar cast from base analysis, 3.0% T.C., 1.5% silicon. Left, step bar cast from same alloy after treatment with 3% nickel. (Courtesy The International Nickel Company, Inc.)

which may be 0.875, 1.20, or 2.00 in. in diameter is placed on corresponding supports 12, 18, or 24 in. apart, respectively, and loaded at the center. Either a specified load is applied and the deflection in inches measured, or the specimen is loaded for deflection and the load is increased gradually until failure occurs. For this latter procedure the *modulus of rupture* is found either from the equation:

$$\text{Modulus of rupture} = \frac{2.546 LS}{D^3}$$

for a round bar, where  $L$  = distance between supports;  $S$  = the breaking load; and  $D$  = the diameter of the test bar; or from the equation:

$$\text{Modulus of rupture} = \frac{3LS}{2BH^2}$$

for a rectangular bar, where  $B$  = the width, and  $H$  = the height of the test bar, and  $L$  and  $S$  have the same significance as above.

### MELTING OF CAST IRON

Most cast iron still is made generally in either a *cupola* or an *air furnace*. However, some of the more modern foundries are using electric furnaces, usually acid lined, in spite of their greater cost of operation. This enables them to secure closer control and to meet more rigid specifications for higher mechanical properties by superheating and inoculation as well as to secure the higher temperatures required for making alloy cast irons.



FIGURE 118. (Left) A cupola ready for tapping. (Courtesy *Metals and Alloys*.)

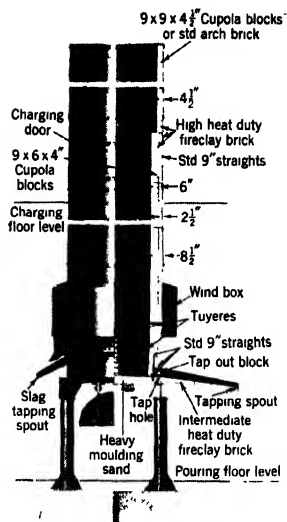


FIGURE 119. (Right) Section of typical cupola. (From *Modern Refractory Practice*, courtesy Harbison-Walker Refractories Company.)

#### CUPOLA MELTING

The cupola is a fuel-fired stack furnace of the first type described previously. The general features of its construction are shown in Fig. 118. It usually consists of a steel shell, less than 30 ft high, whose inside diameter may vary between 18 and 100 in. depending on the height. Common sizes range about 42–84 in., and melt from 5–25 tons of metal each hour.

Only about 15–20 ft of the stack is charged, the balance, above the charging doors, merely serving as a true stack to remove exhaust gases. For protection against the metal, both hot and cold, the shell generally is lined with fire brick (Fig. 119).

The furnace is closed by a drop bottom which is supported from below during the 3–5 hr of the usual run. By removing the supports the entire charge can be dumped through this door onto the foundry floor. While in operation the cupola delivers molten iron continuously, so this simple method of emptying it is quite a desirable one at the close of a day's run. Customarily, about one-half of each day is spent in preparing the sand molds, and the other half in pouring them, using molten metal taken from the cupola.

#### OPERATION OF THE CUPOLA

In starting the cupola, kindling or wood shavings usually are charged first in order to assist firing although auxiliary oil burners can be used for

this purpose. This is followed by coke in a solid column. A layer of pig iron and scrap iron or steel, about 6 in. thick, is placed on this bed layer of coke, then another a layer of coke, and so on, until the furnace is full. If limestone, calcium fluoride, or any of the patented fluxes are used, they usually are charged onto the coke. Any foundry scrap, i.e., waste portions of the finished castings, usually is charged back into the cupola for remelting.

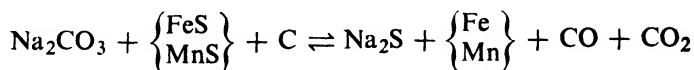
When the furnace is started, air is blown through the wind box, or air chamber, at the bottom of the furnace and enters through the tuyeres under a pressure of 8–30 oz. About 30,000 cu ft of air are required for each ton of iron melted.

The hot gases, largely nitrogen, carbon monoxide, and carbon dioxide, rise through the furnace and melt the iron. With good practice, the charge should move down the furnace continuously at such a rate that the successive iron layers melt at approximately the same point in the furnace, about 15–24 in. above the uppermost tuyeres. Molten iron becomes available in less than 15 min after the air is put on the furnace and flows continually throughout the run.

#### IMPURITY REMOVAL IN THE CUPOLA

The iron generally will lose 2–4% of its weight, largely because of oxidation of silicon, manganese, and iron. Depending upon the coke used, the iron will pick up an additional 0.02–0.08% sulfur as it drops down over the coke, although this is lessened somewhat by proper use of flux and by combination with some of the manganese in the charge. Approximately 0.3% silicon, at most, is lost in the melting although this depends somewhat on the amount present. Consequently, the greatest composition adjustment is made by proper mixing of pig iron and scrap, with steel occasionally being used for this purpose, too. As much as 50–100% of the charge may be scrap, depending on the type of casting being made. Metal made from a charge using much steel scrap sometimes is called *semisteel*, although this term should be considered obsolete as it is strictly a misnomer, the metal still being a true cast iron.

Many foundries successfully use soda ash flux to remove sulfur<sup>10</sup> according to the reaction:



The soda ash, in a definite ratio to the charge, either is added with the coke in the charge or else used in a fore hearth through which the tapped metal

<sup>10</sup> See also, G. S. Evans, *Metals and Alloys*, 16, 1942, 876, 880.

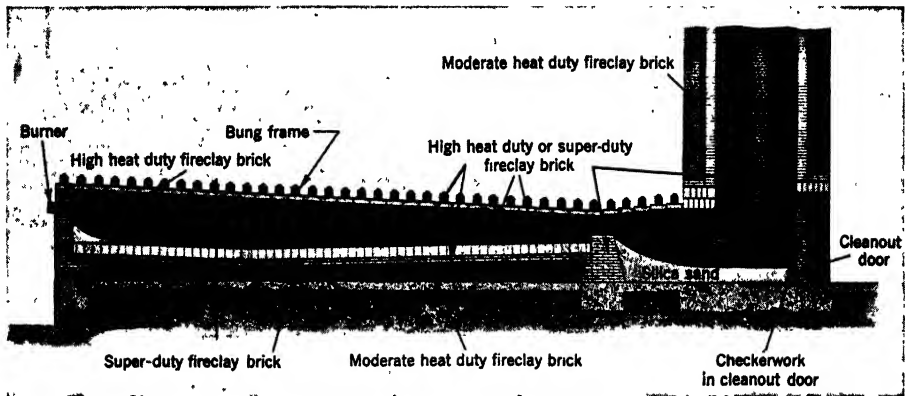


FIGURE 120. Pulverized coal-fired reverberatory-type air furnace for malleable iron. (From *Modern Refractory Practice*, courtesy Harbison-Walker Refractories Company.)

flows to reach the ladle. Since the reaction is not a rapid one the time in which the soda ash is in contact with the molten metal is important if positive results are to be secured.

#### AIR FURNACE MELTING

Much of the white cast iron, especially that which later is to be malleablized, is melted in air furnaces rather than in cupolas. In the furnace illustrated in Fig. 120, the pig iron and scrap are charged on the hearth and melted by radiation from the flame produced by burning pulverized or soft coal, gas, or oil. The hearth is lined with silica sand, using just enough lime to hold it together. American furnaces usually have a capacity of 10–45 tons and require from 4–12 hr to melt a charge, depending on the size.

Primarily, the furnace is intended for melting only, and the composition is adjusted so as to give the proper analysis by use of correct ratios of pig iron, scrap, and steel. To avoid excessive oxidation, the metal should be retained in the furnace only 15–60 min after melting. The correct tapping time usually is judged by the fracture of a test plug of metal periodically taken from the bath. If the iron is to be malleable iron, this will be entirely gray at first, becoming gradually more and more mottled as the holding time is increased. When it finally shows large, clear white crystals with no pinholes at the rim, the iron is ready to be tapped.

Considerable white cast iron for malleablizing also is made by *duplexing*, using the cupola for the initial melting and the electric furnace for the final adjustments of composition and temperature; and some is made by

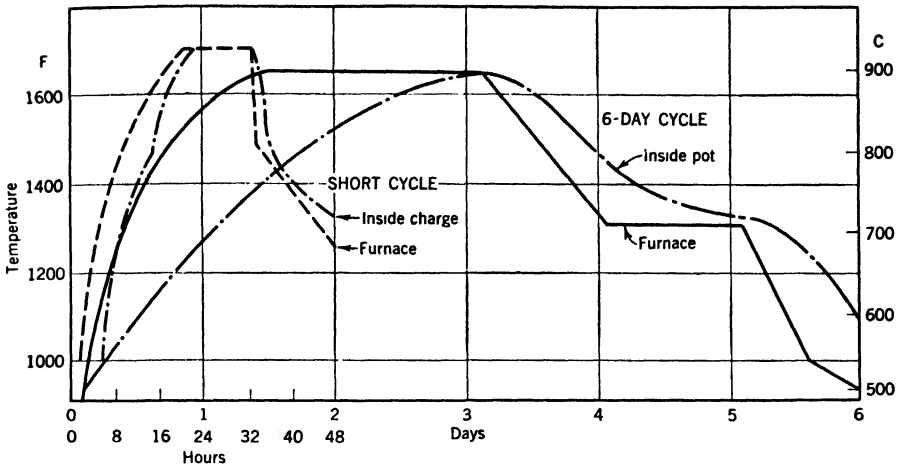


FIGURE 121. Diagrammatic representation of former 6-day and modern controlled-atmosphere short-annealing cycles for malleable iron automotive castings. Note the short time lag between temperature of work and furnace in modern process. (From *Metal Progress*, courtesy American Society for Metals.)

*triplexing*, using the cupola for melting, the Bessemer converter for reducing carbon, and the electric furnace for the final mixing.

#### MALLEABLIZING

*Malleable cast iron*<sup>11</sup> is made by annealing white cast iron of the proper composition. Annealing cycles typical of the old 6-day cycle for annealing in a pot and a modern short cycle in a controlled atmosphere<sup>12</sup> are illustrated diagrammatically in Fig. 121. After the white castings are cleaned from adhering sand, they are packed in cast iron or steel pots or boxes referred to as *saggers*. If the size or shape of the casting requires it, an inert packing material, such as sand, clay, or lime, may be used. The *saggers* then are packed into large annealing ovens heated by coke, coal, oil, gas, or electricity.

In the usual batch-type furnace, a definite cycle must be followed. Because of the brittle nature of the castings at this stage, it is advisable to restrict thermal strains as much as possible by very slow heating, and usually at least 45 hr is required to reach the annealing temperature, which would be of the order of 1600 F (870 C). The castings then are held at this temperature for about 50 hr, and slowly cooled to room temperature for about 60 hr. The complete process takes about 1 week.

<sup>11</sup> See, for a more complete discussion, Ref. 10, at the end of this chapter.

<sup>12</sup> See J. T. Bryce and H. G. Schwab, *Metal Progress*, Jan. 1938, 37.





FIGURE 122. Fracture typical of malleable cast iron. (Specimen courtesy Albany Castings Co.)

The holding time can be decreased if a higher temperature is used; but, in the usual fuel-fired furnace, the variation in temperature is apt to be so great that a sufficient margin below the temperature at which softening starts, i.e., 1800–1900 F (980–1040 C), must be maintained. Under these conditions, a somewhat longer holding time must be used to compensate for temperature differences between various parts of the annealing furnace. By using electric furnaces, which maintain temperatures of 1650–1750 F (900–950 C) with reasonable uniformity, the annealing time has been decreased to as little as 30–48 hr using small loads of carefully controlled castings. This is especially feasible when a continuous furnace, or some similar arrangement, is used, because the important temperature ranges, as can be better comprehended later, are (a) the maximum range at about 1650–1750 F (900–950 C), and (b) the range around and just under 1400 F (725–750 C). As long as the castings are held long enough in the first range and cooled slowly enough through the second, little is gained by using more than moderate cooling rates in the other ranges.

More efficient annealing sometimes can be secured by using two furnaces, one held at the high temperature range and one at the lower temperature. Methods whereby the large heat-absorbing pots are discarded, and the castings are treated either directly or in smaller units also serve to decrease the annealing time.

After annealing, the castings may be warped somewhat. If this is so, they can be straightened by blows with a hammer, since they readily will absorb shock. *Other than this, they are not worked.* The name *malleable cast iron* does not mean that the castings are readily workable; but, rather, that their structure, which after heat-treatment is essentially a mechanical mixture of commercially pure iron and graphite nodules, gives them a greater toughness than they possessed before heat-treatment. The principal purpose of the malleablizing treatment, therefore, is to transform the casting from one structure which is hard and brittle into another structure which is comparatively soft and tough. This process can be speeded up considerably if some form of hot-working can be used, but it is very seldom that a casting has such a simple shape that this is feasible. The fracture of a typical malleable cast iron is shown in Fig. 122.

#### ALLOY CAST IRONS

The use of alloying elements in cast irons will be discussed in more detail later. Usually, alloy cast irons are found in the same basic types as plain

cast irons since the type classification is based upon metallographic structure. The general effect of alloying elements is to give a finer structure, and greater uniformity and homogeneity. All of these factors tend to result in improved mechanical properties. From an engineering viewpoint, the alloy cast irons have a bright future as they possess mechanical characteristics which make them at least equal and frequently superior to wrought products in a competitive price class.

Because of the higher temperatures and greater uniformity required, and the more rigid specifications that must be met, alloy cast irons frequently are made in the electric furnace. However, large tonnages still are made, under careful control, in cupolas.

*For Further Study Refer to*

1. *Metals Handbook*: American Society for Metals, Cleveland, Ohio, 1939 (usually published triennially). A new edition will appear in 1948.
2. *The Making, Shaping, and Treating of Steel*, 5th ed., by J. M. Camp and C. B. Francis: Carnegie-Illinois Steel Corp., Pittsburgh, Pa., 1940.
3. *Cast Metals Handbook*, 2d ed.: American Foundrymen's Association, Chicago, Ill., 1939.
4. *Alloy Cast Irons*: American Foundrymen's Association, Chicago, Ill., 1939.
5. *The Mineral Industry*, edited by G. A. Roush: McGraw-Hill Book Company, Inc., New York (published annually).
6. *Minerals Yearbook*: U.S. Dept. of the Interior, Bureau of Mines (published annually).
7. *Transactions Amer. Inst. of Mining and Metallurgical Engs.*, Iron and Steel Division: A.I.M.E., New York (published annually).
8. *Blast Furnace Practice*, by R. H. Sweetser: McGraw-Hill Book Company, Inc., New York, 1938.
9. *Foundry Work*, by W. C. Stimpson and B. L. Gray: American Technical Society, Chicago, Ill., 1939.
10. *Symposium on Malleable Iron Castings*: American Society for Testing Materials and American Foundrymen's Association, Philadelphia, Pa., 1931.
11. *American Malleable Iron*: Malleable Founders' Society, Cleveland, Ohio, 1944.

## HISTORICAL

UNTIL ABOUT THE MIDDLE OF THE EIGHTEENTH CENTURY, steel, in its present form, was practically unknown although materials having its general properties, such as the famous Damascus and Toledo sword blades, had been in use for hundreds of years. However, in those early times, high-grade metal could be produced only by arduous hand working of purified pig iron. A form of nearly pure iron, now known as *wrought iron*, could be made but large amounts of slag always were admixed with it. By arduously hammering it into thin sheets by hand, welding these together, and subsequently rehammering and rewelding them through several cycles, most of the slag could be eliminated. Some of the best of the early blades contained hundreds of thousands of such welded and hammered layers per inch, as testament to the care and effort that went into their making.

Since no method was known for securing a high enough temperature to melt any quantity of the wrought iron, the slag could not be removed by this simple method except in a very crude and incomplete manner. However, by packing these carefully made blades in charcoal, bone ash, or some other carbonaceous material, the exact nature of which was a vital trade secret of each of the best craftsmen, and heating to a temperature above 1400 F (750 C), i.e., a cherry red, carbon could be diffused into the iron, transforming it into steel. This was the process known as *cementation*. Additional heating and working then gave a fairly homogeneous composition, which could be hardened suitably by heat-treatment.

Some of these "secret processes" were interesting, and in the light of present knowledge remarkably comparable to methods employed today, except in the specific materials used. The general principles of specifications and testing were set up carefully in many instances, and not left entirely to chance. Frequently the manufacturer's integrity was assured further by an unwritten, but sometimes exercised, proviso that, should the blade not pass the tests, the maker's head would be forfeit as a penalty.

About 1740, the status of steel was changed by Benjamin Huntsman's rediscovery in Sheffield, England, that by melting wrought iron in a crucible, it could be separated from its slag and simultaneously combined with the carbon needed to give it the hardness required for tools. The molten metal then could be cast into any form convenient for working. Despite this progressive step, steel still could not be made on a real tonnage basis since about 90–125 lb was the limit of capacity of a single crucible, even though the contents of several crucibles could be melted simultaneously and mixed by pouring them into a single ladle.

In the decade 1850–1860, Henry Bessemer, in England, and William Kelly, in the United States, worked with the revolutionary idea of blowing air through liquid pig iron to oxidize and remove the impurities. Although Kelly finally abandoned his efforts until a later period, Bessemer persevered and ultimately succeeded in making satisfactory steel after it was found by R. Mushet that the harmful effects of some of the remaining impurities, notably oxygen and sulfur, could be minimized by the addition of manganese in the form of spiegeleisen. The perfection of the Bessemer process really marked the start of the steel age and it remained the leading method for producing steel from 1870 to 1910, a period in which quantity rather than quality was the goal, and mass production in the consumer industries had yet to affect American metallurgical practice.

Although a furnace of the air or reverberatory type had been used for puddling as early as 1784 by Henry Cort in England, and J. H. Heath had suggested its use for steel as early as 1845, steel could not be melted in it satisfactorily until about 1858 when William Siemens, and his brother Frederick, in England, discovered the regenerative system for preheating the gas and air going into the furnace. In 1864, the Martin brothers modified the Siemens' "pig and ore" process by using large amounts of relatively inexpensive steel scrap, in addition to pig iron, to form the molten bath for purification. This initiated the modern "pig and scrap" process which usually is called the *Siemens-Martin process*. The ability of the open-hearth process to use large quantities of steel scrap was especially important since the Bessemer process was unable to do so, and comparatively large amounts of this material were accumulating as a practically useless product. Some 20 years later, basic linings in the open-hearth furnace were introduced to facilitate phosphorus removal after Thomas and Gilchrist had used them in England for Bessemer converters in 1877.

The twentieth century has seen the development of both the Bessemer and the open-hearth processes. In addition, the electric furnace has been perfected for the refining of steel, as well as various methods of combining several processes, called *duplexing* or *triplexing*, for increasing efficiency.

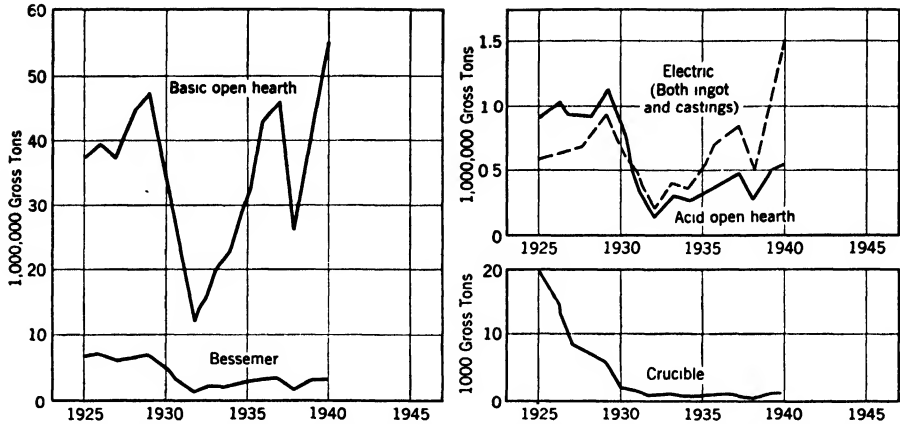


FIGURE 123. Graphic representation of the tonnages produced in the United States since 1925 by the five important steelmaking processes. (After U. S. Bureau of Mines data.)

Tonnage trends since 1925 in these five important steelmaking processes, basic open hearth, Bessemer, electric, acid open hearth, and crucible, can be seen from the graphs of Fig. 123.

The twentieth century also has seen the development of a new synthetic process for making wrought iron, the Aston process, which bids fair to displace permanently the products of the older hand and mechanical furnaces.

### *Wrought Iron*

#### THE PUDDLING PROCESS

Wrought iron has been hand puddled for centuries, and this method is used still to a very limited extent in the United States. It was the first attempt to refine pig iron by using the oxygen in iron oxide to oxidize its impurities. The difficulty which the process could surmount only partially was the increase in the melting point of iron as the refining proceeded, from a temperature of about 2000 F (1100 C) for pig iron, which was obtainable, to a temperature of about 2800 F (1550 C) for commercially pure iron, which, because of their construction, was beyond the capabilities of the puddling furnaces available. A temperature of about 2600 F (1430 C) could be maintained, and this was sufficient to keep the slag in a molten condition throughout the heat even though the iron became more viscous with time because of the purification taking place.

#### HAND PUDDLING

Furnaces for *hand puddling* (Fig. 124) were similar in many ways to the air furnaces already mentioned, but frequently were built in pairs, back to

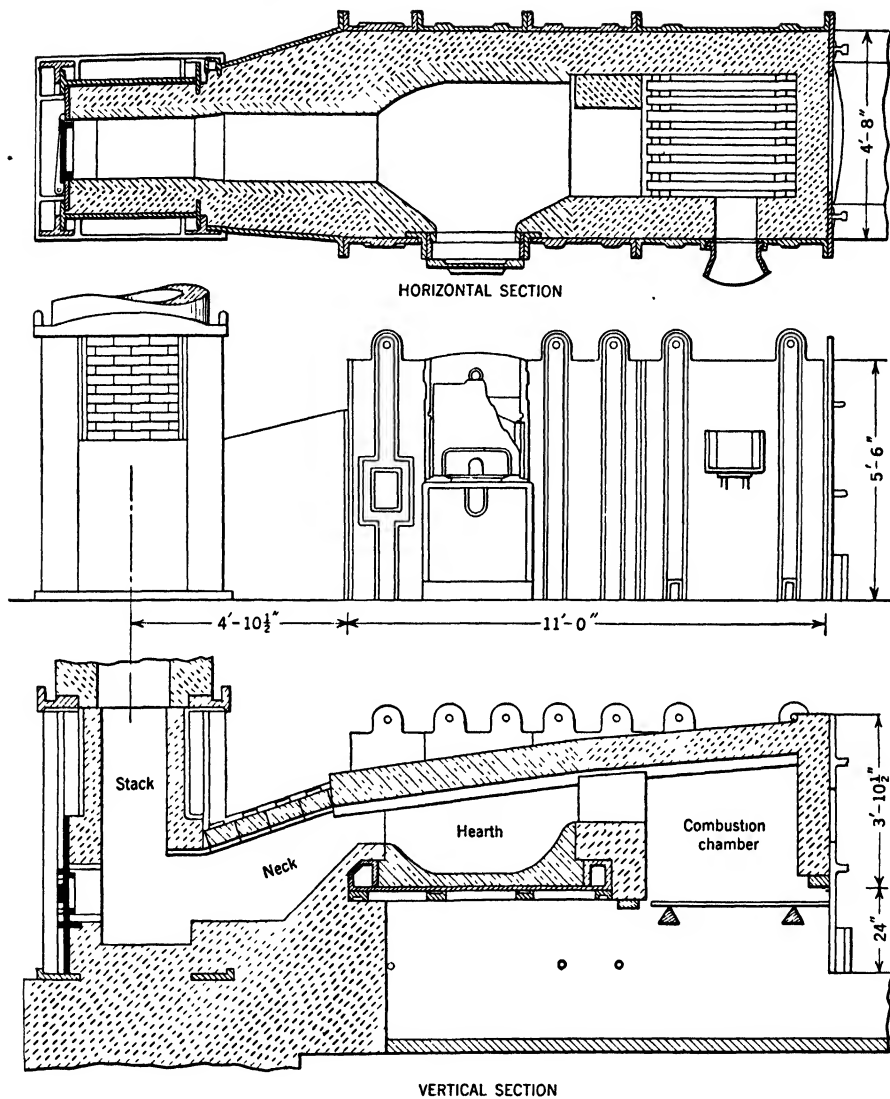


FIGURE 124. Drawings showing plan and sections of a puddling furnace. (From *The Making, Shaping, and Treating of Steel*, by permission of Carnegie-Illinois Steel Corporation.)

back, in order to reduce the heat loss by radiation. They varied in capacity from 300 to 1500 lb or more, although the 500 lb furnace was probably the most common size. Gas, oil, soft coal, or pulverized coal were common methods of heating; and the choice usually depended on both the comparative costs and the impurity content, chiefly sulfur, of the fuels available.

**LINING** The hearth usually was lined or *fettled* with an active basic refractory lining, which was essentially a relatively pure form of hematite; and this, with the iron oxidized during melting, served as the active oxidizing agent. The lining, of course, suffered both chemical and mechanical wear, and had to be repaired frequently.

**PUDDLING** Iron pigs usually were charged by hand, frequently after preheating in the exhaust flue. By firing vigorously, they could be melted down in 25–30 min. During this melting period, the silicon and manganese were oxidized almost entirely. Iron oxide or roll scale then was added and mixed thoroughly with the molten pig, and the temperature decreased so that the phosphorus, and possibly some of the sulfur, oxidized ahead of the carbon. As soon as the carbon started to oxidize, the carbon monoxide formed agitated the bath into a “boil.” As a result, the bath would swell, and force the slag out of the furnace. After 20–25 min of this, during which the puddler stirred or rabbled the charge vigorously with a long iron rabble shaped like a hoe, the metal began to *come to nature* or grow pasty.

**BALLING AND SQUEEZING** On continued mixing for 6–8 min all of the charge became pasty; and the metal was *balled*, each ball weighing only 125–150 lb to facilitate handling. The balls then were withdrawn and *squeezed* in an eccentric rotary squeezer to eliminate as much of the slag as possible. The entire operation from charging to squeezing took about  $1\frac{1}{2}$  hr.

**ROLLING** The squeezed ball then was rolled between grooved rolls into a bar, about  $\frac{3}{4}$  in. thick and  $2\frac{1}{2}$ –8 in. wide, called a *muck bar*, which contained 1–2% of entrapped slag. The muck bar was cut into strips, piled into a bundle (Fig. 125), bound with wire, heated to a welding heat, and rerolled. The rolled bar, known as *merchant or single-refined bar*, was the usual form of wrought iron, although high-grade material was piled further and rolled while hot to give *double-refined bar*. Rolling ejected more slag, and caused the remainder to be drawn out into fibers parallel to the direction of rolling. It was comparatively simple, therefore, to distinguish between the transverse and longitudinal sections of the material (Fig. 126) unless the bar had been cross rolled. The constituent other than slag is essentially pure iron in good grades of wrought iron although this cannot be established definitely until the specimen is etched. Definitions for the various terms relating to wrought iron are given in A.S.T.M. Standard A81.

No two puddlers could produce metal which was identical in nature so the piling operation served to mix and homogenize the product of the different furnaces as well as to remove the slag. Sometimes a cheaper grade of diluted wrought iron was made by bundling scrap wrought iron or steel in with the pile, and rolling it all out together. This was usually an inferior

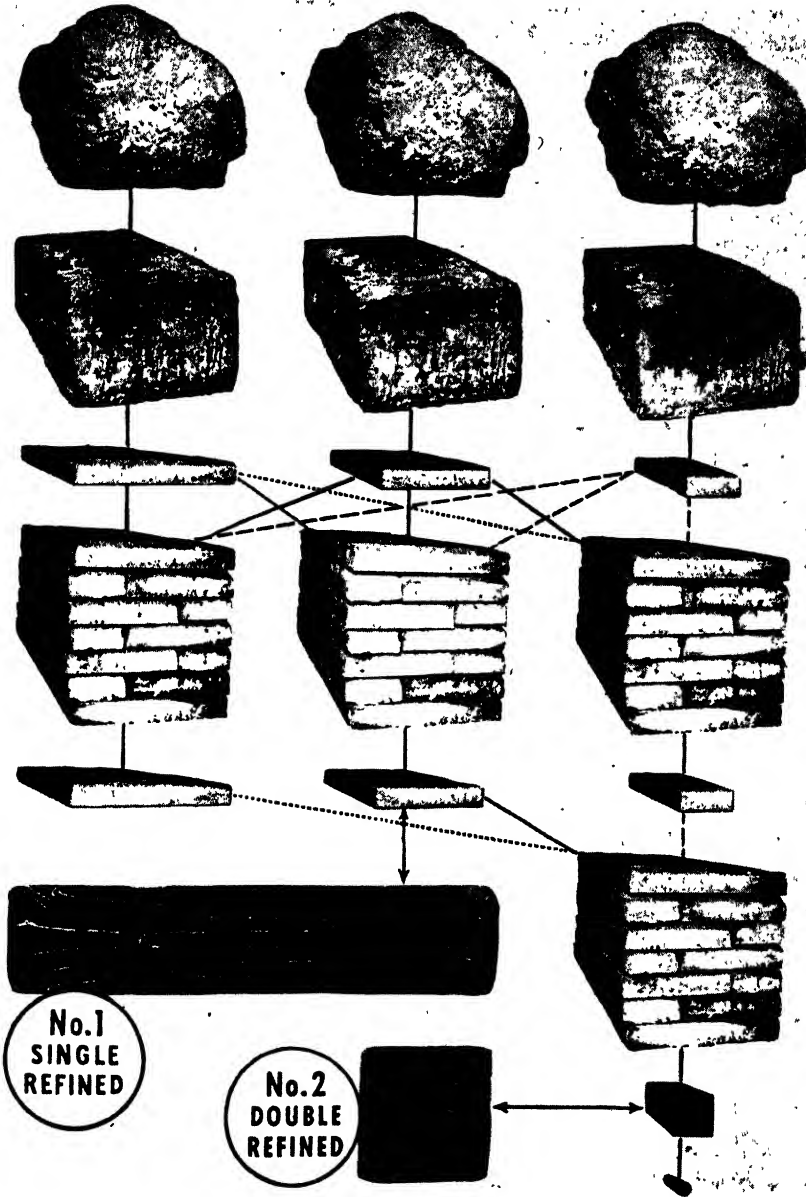


FIGURE 125. Schematic illustration of stages in the homogenization of Byers-Aston wrought iron. Sponge balls, weighing 7000 lb, first are pressed into 20-in. by 20-in. blooms under 900 tons pressure. These are reduced to 21-in. by 3-in., 14-in. by 3-in., or 7-in. by 3-in. slabs, only one size being produced from a single bloom. The slabs then are piled, brought to welding temperature, and rerolled to one of the sizes given above. This *single-refined* wrought iron is piled again, heated, and rerolled to an appropriate size, in this instance a 4-in. by 4-in. billet since the ultimate product will be staybolts, of *double-refined* wrought iron. (Courtesy A. M. Byers Co.)



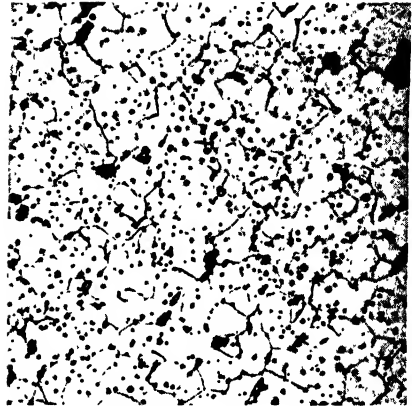
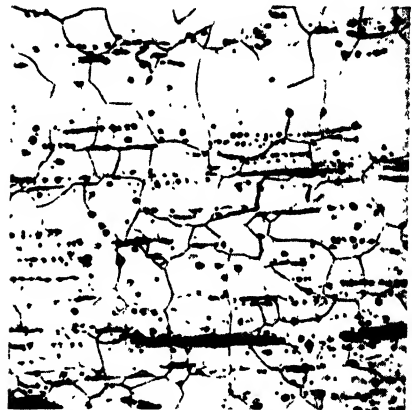
*a (Left)**a (Right)**b (Left)**b (Right)*

FIGURE 126. Metallographic structures typical of wrought iron.  $\times 100$ . *a*. Transverse section, unetched (*left*) and etched with nital (*right*). *b*. Longitudinal section, unetched (*left*) and etched with nital (*right*).

grade; and under the microscope showed the presence of appreciable amounts of various dark etching constituents resulting from the presence of combined carbon (Fig. 127). Wrought iron that has been refined only partially will show this same type of defective structure, but slag stringers also will be present in this material.

Common and refined iron bars are covered by A.S.T.M. Standards A85 and A41 respectively, and single- and double-refined wrought-iron bars by A.S.T.M. Standard A189. In each case the maximum allowable per cent manganese and the minimum mechanical properties are specified. The presence of manganese greater than this limit is the best evidence of steel adulteration, as good wrought iron ordinarily contains little if any.

The slag, which usually is found in wrought iron in amounts of 1–2%,

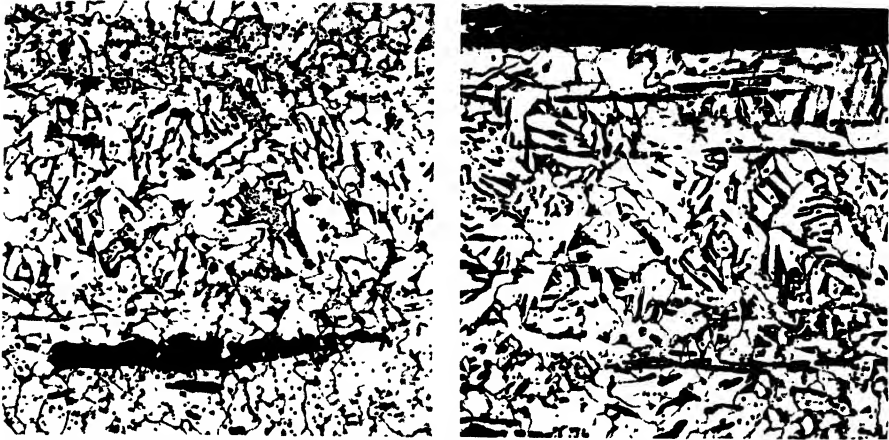


FIGURE 127. Metallographic structures of poorly made wrought iron. Etched with nital.  $\times 100$ . *a.* (Left) Steel scrap adulteration. The presence of areas in which there is the dark etching intimate mixture of iron and iron carbide, called pearlite, but no admixed slag indicates the use of steel scrap as an adulterant. *b.* (Right) Incompletely refined. Normal slag particles are present but the presence of pearlite areas indicates incomplete refining. (From *Quality Standards for Wrought Iron*, courtesy Amer. Soc. for Testing Materials.)

contains as a rule the oxides of iron, manganese, phosphorus, and silicon, as well as those of aluminum, calcium, and magnesium. These generally are found, in a polished specimen studied under the microscope, associated in three general forms: (*a*) an *iron oxide*, probably  $\text{FeO}$ , which is black; (*b*) a *silicate*, probably of iron and manganese such as  $2(\text{FeO}, \text{MnO}) \cdot \text{SiO}_2$ , which is dark gray; and (*c*) an *iron phosphate*, probably  $3\text{FeO} \cdot \text{P}_2\text{O}_5$ , which is light gray in color. The amounts of each will vary with the conditions of manufacture. These three constituents can be recognized readily in Fig. 128.



FIGURE 128. Structure within slag particle in wrought iron. Unetched.  $\times 250$ . The light etching areas are probably an iron phosphate, the dark gray areas an iron silicate, and the black areas excess iron oxide.

#### IMPROVED PROCESSES

Although many attempts were made to increase the efficiency of the puddling process by use of mechanical puddlers, only the Ely puddler<sup>1</sup>

<sup>1</sup> See, F. H. Dechant, *Year Book of the Amer. Iron and Steel Inst.*, 1925, 337-347.

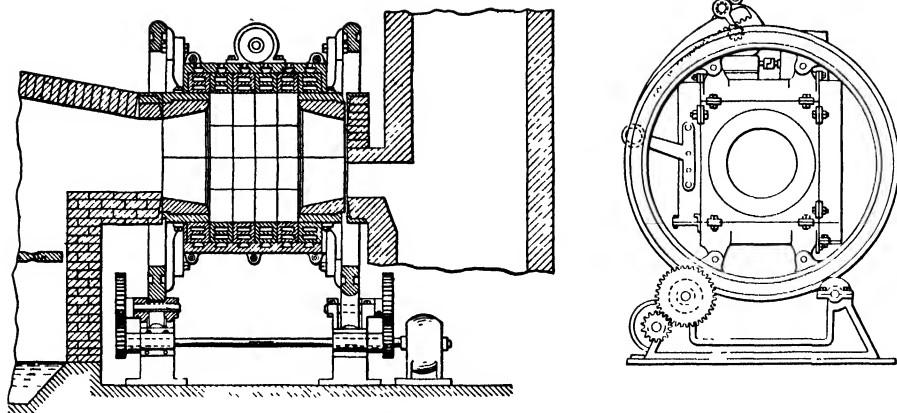


FIGURE 129. Longitudinal section (*left*) and end view (*right*) of Ely puddling furnace.

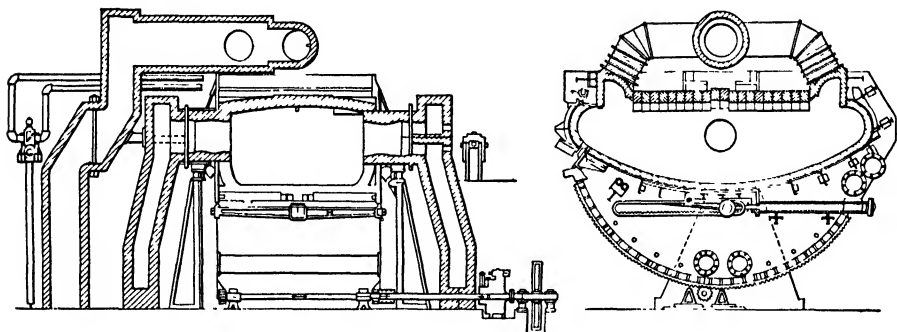


FIGURE 130. Cross section (*left*) and longitudinal section (*right*) of Roe puddling machine.

(Fig. 129), in which the furnace oscillated or rotated about a longitudinal axis, and the Roe furnace<sup>2</sup> (Fig. 130), which oscillated endwise about a transverse axis, were successful. During the period 1920–30 hand puddling practically was discarded in favor of the mechanical processes, but today even they have fallen out of use. The manual puddler produced about 2800 lb of iron per day of strenuous work, in balls weighing about 150–200 lb each. The Ely furnace produced about 11,000 lb of wrought iron in 8 hr in 750–1000-lb balls; and the Roe puddler produced an 8000–10,000-lb ball every hour. Both these mechanical processes required iron in a molten condition, and both endeavored to duplicate the conditions of hand puddling as closely as possible but on a larger scale. The chief factors incident to the downfall of both of them were (a) the expense of operation; (b) the high cost of wrought iron in comparison with steel; (c) the com-

<sup>2</sup> See, J. P. Roe, *Year Book of the Amer. Iron and Steel Inst.*, 1925, 348–360.

petition of Byers-Aston lower cost iron; and (d) the general decline in demand for wrought iron.

#### THE BYERS-ASTON PROCESS

Most modern wrought iron is made by the Byers-Aston process.<sup>3</sup> In this process pig iron of standard Bessemer grade is melted in a cupola; desulfurized in suitable ladles; blown in a small Bessemer converter to eliminate silicon, manganese, and carbon; and tapped into a ladle. Meanwhile, an iron silicate slag is made up, melted in a small tilting open-hearth furnace, and held in a ladle, in a molten condition but still at a temperature several hundred degrees lower than that of the refined iron.

The iron then is poured into the slag ladle in a continuous stream (Fig. 131), an operation known as *shotting*. Because of the difference in temperature it is solidified continuously and rapidly. This rapid solidification liberates the dissolved gases with sufficient force to shatter the metal into small fragments which settle into the bottom of the ladle, weld together, and are collected as a sponge ball weighing 6000–8000 lb when the excess slag is poured off.

These *sponge balls* can be delivered to the platform of a 900-ton electrically driven press, for squeezing into solid blooms for rolling, at the rate of one every 5 min. The difficulties of the older processes from a competitive viewpoint are obvious, especially since the wrought iron so made seems to be equal, if not superior, to that made by the older processes.<sup>4</sup> A large plant, with a daily capacity in excess of 800 tons, using this process, is operated by the A. M. Byers Company in the Pittsburgh district.

#### CHEMICAL ANALYSIS OF WROUGHT IRON

Chemical analyses of wrought iron are sometimes difficult to interpret unless the metal analysis is separated from that of the slag to reveal the

<sup>3</sup> See Ref. 6 at the end of this chapter.

<sup>4</sup> See, for example, H. S. Rawdon and C. A. Knight, *Bur. Stand. Journ. Res.*, 3, 1929, 953–992.



FIGURE 131. "Shotting," in the Byers-Aston process for making wrought iron, by pouring liquid iron into liquid slag. (Courtesy A. M. Byers Co.)

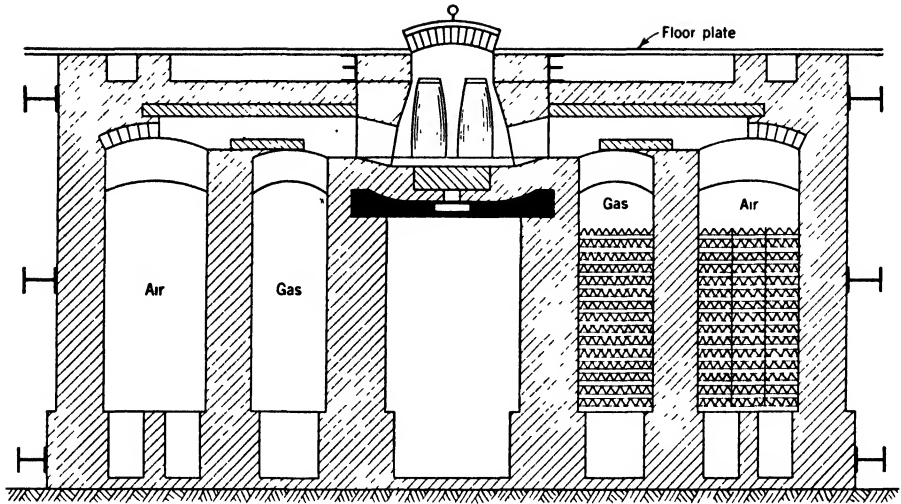


FIGURE 132. Cross section through typical crucible furnace. (From *Metals Handbook*, courtesy American Society for Metals.)

metalloid distribution between the two. Thus, a typical analysis may show 0.02–0.08% carbon; 0.10–1.20% silicon, ordinarily almost entirely in the slag as silicates; 0.02–0.03% sulfur, although values of 0.05% or higher are not uncommon; 0.10–0.23% phosphorus, existing partly in the base metal and partly in the slag; and usually below 0.05% manganese, with amounts greater than 0.10% indicating steel scrap adulteration as a rule. In A.S.T.M. Standards for wrought iron, manganese is usually the only element whose maximum percentage is specified because it will rise only if steel scrap has been mixed into the wrought iron. Phosphorus is much less harmful as an alloying element in reasonably pure iron<sup>5</sup> than it is in steel or cast iron, and many of the valuable properties of wrought iron arise from the fact that it is actually an iron-phosphorus alloy.

## *Steel*

### CRUCIBLE STEEL

Wrought iron melted in sealed crucibles in the presence of a carburizer was the original crucible steel. Because of the limited quantities in which it could be produced—each furnace, now usually of the Siemens regenerative type (Fig. 132) had a capacity of 30 pots, each holding a little less than 100 lb of metal, and would yield about six heats of 2800 lb each every 24 hr, or 33 heats per week—and of the competition of the electric induction furnaces, in particular, comparatively little steel is made by this method today. The process would not remove impurities, other than slag; and was

<sup>5</sup> See, for example, G. T. Motor, *Iron Age*, 146, Oct. 21, 1940, 27–32.

primarily intended only for melting, as the raw materials must be especially low in phosphorus and sulfur. This increases the cost appreciably. No chemical change occurs in the crucible process except the increase in carbon to the desired figure, and some pickup of silicon from the crucible.

Today although some steel is made in small lots by a so-called crucible process, it is not true crucible steel. Even the method practically has been abandoned except in one plant where the equipment is available, and is convenient to use for making small lots of steel.

#### ACID BESSEMER STEEL

Somewhat less than 10% of the steel made today is made by the acid Bessemer process. This is considerably greater than its output during the depression of the early 1930's. The increase, however, results not only from definite improvements in the process, but also from developments in alloys which were suited particularly to manufacture by the Bessemer process.

(The process makes use of two well-known, but frequently overlooked, facts: (a) the oxidation of most chemical elements results in an evolution of heat, and the greater and more rapid this evolution is, the higher will be the temperature so produced; (b) the greater the chemical activity of an element, the more readily it tends to oxidize, and usually the greater is the energy liberated by its oxidation.)

Pig iron contains approximately 6% of impurities, most of which can be oxidized more readily than iron because they are more active chemically than it is. The heat generated by this oxidation not only is sufficient to keep the pig iron molten, but frequently is sufficient to superheat the remaining molten steel to such an extent that solid scrap must be added to reduce the temperature. Despite this fact, the process probably never will be a real scrap user since (a) the amount of scrap that can be added is limited to a maximum of about 15% because of the absence of any external source of heat, and (b) only large solid pieces of scrap are suitable for cooling off the bath. Most of these are available in the Bessemer plant itself.

A cross section of a typical converter plant is shown in Fig. 133. The converters are large eccentric or concentric vessels (Fig. 134) about 11 ft in diameter, 18 ft long, and shaped like a pear with the small end up. They are lined with an acid refractory material containing a high percentage of silica.

Into a converter is poured 5–30 tons, depending on the size, of molten pig iron of the proper composition. During the loading stage, the converter

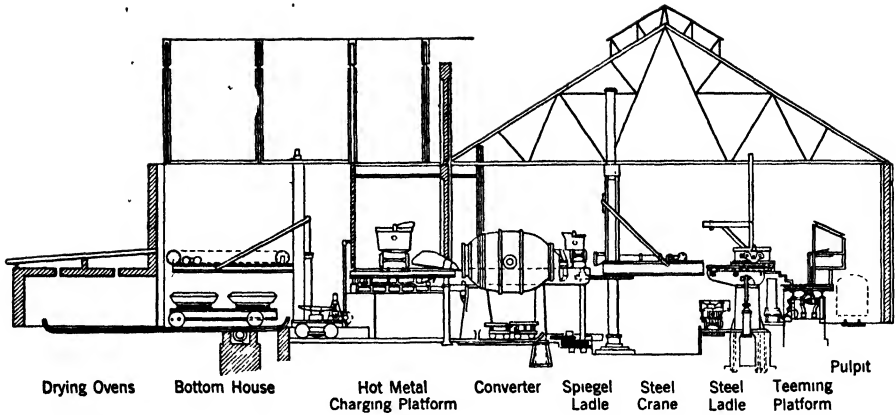


FIGURE 133. Cross section of a converter plant. (From *The Making, Shaping, and Treating of Steel*, by permission of Carnegie-Illinois Steel Corporation.)

is tipped. In this way all the metal can be accommodated in its belly without flowing down the tuyeres and blocking them. As the converter is tipped upright, air is forced in through these tuyeres, a typical set of which consists of 12 holes, about  $\frac{1}{2} - \frac{7}{8}$  in. in diameter, in cylindrical bricks. A pressure of about 20 psi is customary. Some scrap then is added to assist in controlling the temperature. The most serious wear occurs on the converter bottom and tuyeres. These bottoms have an average life of about twenty heats, and can be replaced readily.

Strictly, therefore, the Bessemer converter is a fuel-fired furnace of the first type mentioned previously, in which the charge, fuel, and products of combustion all are mixed intimately. This is true despite the fact that the fuel is not added separately; but, rather, forms an integral part of the molten charge. It is the only steel-refining furnace which falls in this classification.

#### ( IMPURITY REMOVAL DURING THE BLOW

According to the chemical law of mass action, iron will be oxidized first, forming  $\text{FeO}$  which will dissolve in the molten metal. This dissolved  $\text{FeO}$  will then attack the dissolved silicon, which could vary in the pig iron from 1-2.25%, oxidizing it to  $\text{SiO}_2$  and forming with it a slag, for example  $x\text{FeO} \cdot y\text{SiO}_2$ . Both of these reactions will liberate large amounts of heat. Manganese, which must not run over 0.6% if the slag is not to be too fluid, will oxidize almost simultaneously with the silicon during the first stage of the blow, and it too will form a slag, for example  $x\text{MnO} \cdot y\text{SiO}_2$ , liberating energy.

During this stage the flame issuing from the mouth of the converter is



FIGURE 134a. Eccentric-type converters in action with the blow near the end of the boil. (Courtesy Jones & Laughlin Steel Corporation.)

short, reddish-brown in color, and of low luminosity. This persists until essentially all the silicon and manganese are oxidized, a period of 6–10 min, as a rule. Toward the end of this stage, the carbon begins to oxidize, and the flame changes in character, becoming a yellowish-white color, and increasing in length until it reaches about 30 ft or more. When all the car-





FIGURE 134 (continued) *b*. View of a concentric-type converter, with the blow near the beginning of the boil. (From *The Making, Shaping, and Treating of Steel*, by permission of Carnegie-Illinois Steel Corporation.)

bon is eliminated, the flame suddenly drops, the vessel is turned again on its side, and the blast shut off. The blow is completed in 10–12 min from the time of charging. This *blown metal* contains 0.003–0.01% silicon, 0.02–0.06% manganese, 0.02–0.10% carbon, substantially all the phosphorus originally in the pig, but usually not more than 0.06–0.11% phosphorus, and 0.04–0.06% sulfur, about all that was in the pig. In addition, it may contain up to 0.35–0.65% FeO and 0.01–0.02% nitrogen.)

#### ( TREATMENT OF METAL AFTER THE BLOW

In order to make the blown metal suitable for casting into ingots, two things must be done: (*a*) the carbon must be brought to the correct level, a process called *recarburizing*; and (*b*) the oxygen must be reduced to the correct value, called *deoxidizing*.

Any source of carbon can be used for the former and a *ferromanganese*, a *ferrosilicon*, or *aluminum* is usually used for the latter operation, although the two processes sometimes are combined by adding to the metal a special

pig iron called *spiegeleisen* which is high in carbon, silicon, and manganese. In Bessemer practice ferromanganese additions usually must be made in the ladle, resulting in a loss of at least 10–20% of the manganese added. )

#### FERROMANGANESE

Specification grades of ferromanganese, covered by A.S.T.M. Standard A99, will analyze:

78–82% Mn	:
7.5 % C (max)	
1.25% Si (max)	
0.35% P (max)	
0.05% S (max)	

with the remainder iron. This material will melt at about 2300 F (1250 C).

Low-carbon grades containing 80–85% manganese, 0.10–0.75% carbon (max), and either 1.25% silicon (max) or 7.00% silicon (max), and medium-carbon grades containing 80–85% manganese with 1.00–3.00% carbon (max), and anywhere from 1.25–2.50% silicon (max), depending upon the grade, are also available. However, these low- and medium-carbon grades are more likely to be used for making manganese alloy steels than for simple deoxidation.

#### FERROSILICON

The several grades of ferrosilicon used are covered by A.S.T.M. Standard A100. They may contain 47–95% silicon, depending on the grade, with 0.15% carbon (max), and less than 0.05% phosphorus or sulfur. Higher carbon grades containing 8–30% silicon, and 0.50–1.50% carbon also are used. These products are made in the electric furnace by electrothermic reduction, and come in quite large chunks which are relatively brittle and can be broken readily.

#### SPIEGELEISEN

Spiegeleisen is essentially a high-manganese pig iron. Three grades are included in A.S.T.M. Standard A98, covering the limits 16.00–28.00% manganese, 6.50% carbon (max), 0.25% phosphorus (max), and 0.05% sulfur (max). The alloy can be obtained, for any grade, within the limits 1.00–4.50% silicon (max), as specified. These materials probably will melt within the range 1950–2250 F (1070–1230 C). Spiegeleisen is made in a blast furnace, using a process which is similar to that used for making ordinary pig iron. The high amount of manganese in the product introduces certain necessary modifications.

## OBJECTIONS TO ACID BESSEMER STEELS

The principal objections to acid Bessemer steels have been threefold: (a) the phosphorus could not be eliminated<sup>6</sup> and, therefore, either it had to be tolerated or else expensive, and difficult to secure, low-phosphorus pig had to be used; (b) the sulfur could not be eliminated and either had to be allowed or controlled by excess manganese additions; (c) the oxygen and nitrogen content was apt to run high, tending to give a steel which was somewhat more difficult to bend. This might or might not be a disadvantage, and, if necessary, it could be overcome to some extent by proper deoxidation.

When free-machining screw-stock alloys are being made, these are not disadvantages because these alloys, as will be discussed later, generally run high in both sulfur and phosphorus. For certain other applications, such as stock for welded pipe, bolts and nuts, concrete reinforcing bars, and small structural shapes, they are not serious so Bessemer steel finds its main applications today in these fields. Subsequent improvements in quality control may increase its field of application considerably.

## CONTROL IN THE ACID BESSEMER PROCESS

The largest inherent objection to the process outside of the three given above is its speed, which is at once an advantage and a disadvantage. Precision control, in particular, has been difficult to secure because the appearance of the flame to the blower's eye has been his only judge of the state of the process. It is only logical to assume that, as different charges would vary somewhat in analysis and different operators would react differently to the flame, the metal produced would vary appreciably, although much of this variation could be evened out by mixing together the molten metal from several converters or from several blows in large enclosed, refractory-lined, mixing ladles similar to that shown in Fig. 111.

Recent work of the Jones & Laughlin Steel Corporation in developing an automatic control based upon the use of photoelectric cells, therefore, appears to be particularly promising as tending toward greater uniformity and accuracy of control.<sup>7</sup> It should, in particular, result in a lower oxygen content of the blown metal, because a good deal of the oxygen is introduced during the short flashback interval after the flame drops (point marked

<sup>6</sup> This objection has now been overcome, to some extent at least, by the Yocom Process (see G. M. Yocom, *Trans. A.I.M.E.*, **145**, 1941, 160-174) which, however, is not used widely as yet.

<sup>7</sup> See, for example, H. K. Work, *Trans. A.I.M.E.*, **145**, 1941, 132-150; also H. T. Bowman, *Trans. A.I.M.E.*, **150**, 1942, 113-125.

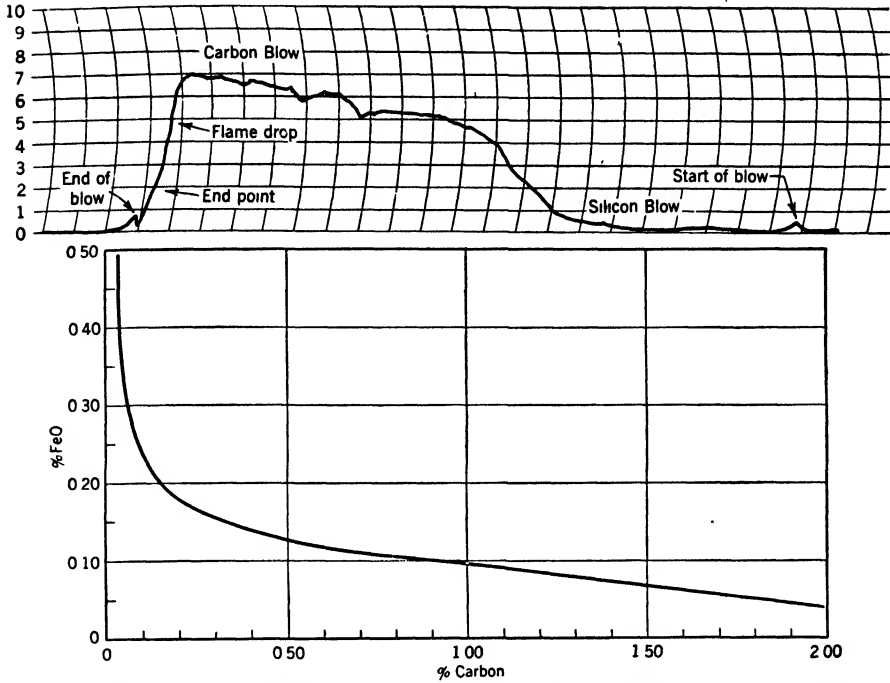


FIGURE 135a. (Upper) Chart showing variation of flame intensity with time during a typical acid Bessemer cycle. Note that the time scale runs from right to left. b. (Lower) Relationship between carbon and iron oxide in blown metal. (From H. T. Bowman, *Trans. A.I.M.E.*, 150, 1942, 113.)

“End of blow” on the chart in Fig. 135a), and while the converter is tipped. )

CHEMICAL ANALYSIS OF ACID BESSEMER STEEL

Bessemer steel as made today seldom, if ever, contains more than 0.35% carbon, and most frequently runs considerably lower. Because of the inability of the process to remove phosphorus unless duplexing or special treatments are used, the steel usually will contain from 0.08–0.11% of this element. This value is generally the key to a Bessemer analysis. Sulfur content may vary, up to a maximum of about 0.25%, depending upon the application intended, although 0.07–0.08% sulfur (max) is most common. For some uses, notably those related to high machinability, sulfur even may be added intentionally. Silicon is usually low, but either it or the manganese, which may run as high as 1%, may increase during the deoxidation.

Duplexing, of course, will obscure any of the above limits, and make it practically impossible to detect, from analysis alone, whether or not a steel has been made by the Bessemer process.

## THE BASIC BESSEMER PROCESS

Since phosphorus can be removed in a basic process as calcium phosphate, some features of the basic Bessemer process should be mentioned. Such a process actually is used in Europe although it has not been employed in the United States for many years. Because the temperatures in a Bessemer converter are so high that carbon will oxidize before phosphorus, not only must a basic lining and slag be used, but also there must be sufficient phosphorus present to furnish heat during a third blowing stage, after the carbon has been removed. This requires a pig iron containing more than 1.8% phosphorus and low in silicon. Although ores in this country generally run above 0.10% phosphorus, they are much below this higher figure, and consequently the method would not be feasible for this reason, even if a far superior method for removing phosphorus, viz., the basic open-hearth process, were not available. Furthermore, since the oxidation of phosphorus gives even less flame than silicon or manganese, it is even more difficult to stop the process at a point which will give optimum phosphorus removal with minimum oxidation. For this reason, the third stage, or *afterblow*, has to be run either on a fixed time basis or else for a definite number of revolutions of the blowing engine.

## THE OPEN-HEARTH PROCESSES

Better than 85% of the steel used today is made in the basic open-hearth furnace by the so-called Siemens-Martin process. The reasons for this are numerous. In a typical furnace about 100 tons or more of steel can be refined every 8 hr, a relatively large-scale operation. About one-half of the charge into the furnace is scrap, thus furnishing both a very satisfactory means for disposing of this otherwise useless commodity, and decreasing, by dilution, the impurities that must be removed by oxidation. All of the five significant impurities can be removed in the process although control over sulfur is not as yet all that could be desired. The most important development in modern times is probably the ability of the metallurgist, by means of this process, to turn out a *controlled steel*, that is, a steel which will react to treatment in a predictable manner and which will give reproducible results. It is the only process which will permit this on a large-scale tonnage basis; and although the various techniques required by no means have been perfected entirely, they hold definite promise for the future.

## THE BASIC OPEN-HEARTH FURNACE

Figure 136 shows the arrangement of a modern open-hearth furnace. It can be seen that it has two essential parts: (a) the *hearth*; and (b) the *air*

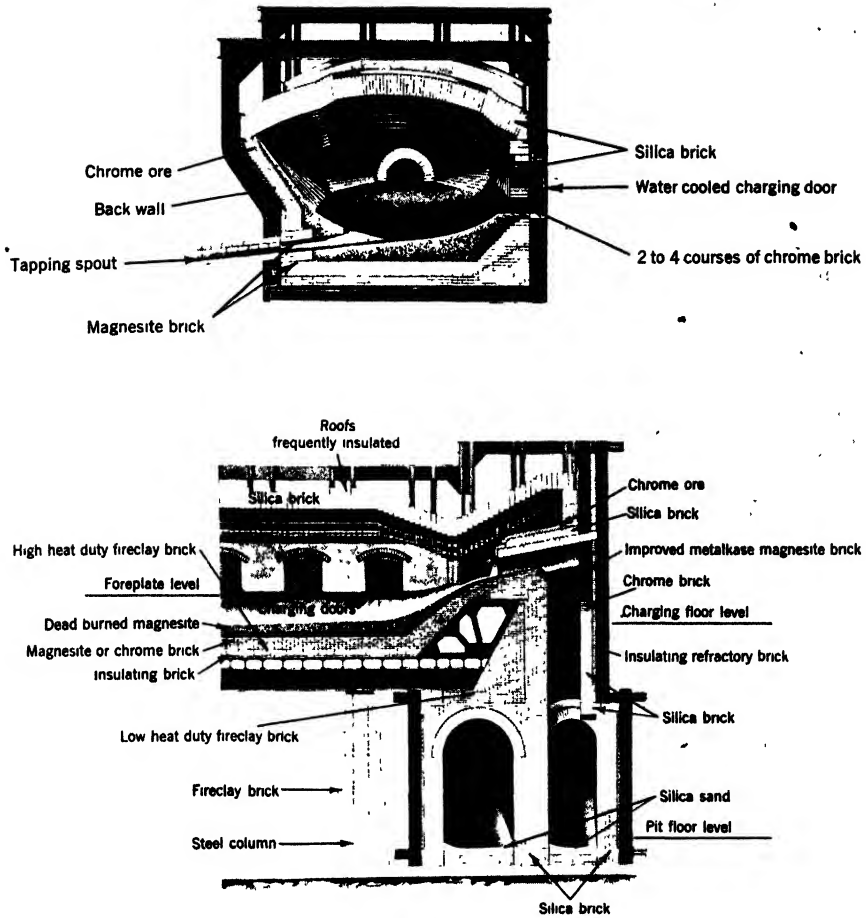


FIGURE 136. Sections through a typical basic open-hearth furnace. (From *Modern Refractory Practice*, courtesy Harbison-Walker Refractories Company.)

and gas heating system, including the firing ports, the regenerative chambers, and the flues, reversing valves, and stack.

**THE HEARTH** The hearth upon which the steel is made is an elliptically shaped vessel, 25–35 in. deep and lined with any suitable basic refractory. Magnesite brick, covered with a mixture of burned magnesite or dolomite and open-hearth slag, is the commonly used basic lining. This hearth is finished with walls and a roof of silica brick to form a combustion chamber. Suitable spaces for doors through which the operations may be controlled are left on one side of the furnace, and firing ports are located at the ends of the furnace. Usually the furnace is sealed as well as possible in order to secure better atmosphere control, and both the side walls of the

furnace and the roof are insulated to increase the thermal efficiency,<sup>8</sup> although too much insulation is apt to cause melting of the roof- and other bricks unless proper roof temperature-control installations are made.

**THE HEATING SYSTEM** The air and gas regenerators consist essentially of large chambers about 31 ft long, 8–11 ft wide, and 16 ft high, located about half above and half below the casting floor. They are filled with a checkerwork of refractory brick, and are so connected with the reversing valves and stack by flue systems that the checkerwork can be heated to the required temperatures during one cycle by the passage of the exhaust gases through them, and then be cooled on the following cycle while preheating the entering gas or air. The cycle of reversal is usually of the order of 15–20 min, subject to automatic control. Such fuels as oil, natural or coke oven gas, and pulverized coal usually are brought directly to the firing ports and only the air is preheated. It should be obvious that each firing port will have to be designed for the particular fuel used if high efficiency is desired. Generally the firing ports are so arranged that the air enters above the fuel, and so built that the flame impinges against the bath rather than the roof. Both of these conditions serve to keep the roof from overheating.

#### THE BASIC OPEN-HEARTH PROCESS

**CHARGING THE FURNACE** Since the basic open-hearth process makes maximum use of the various chemical reactions which occur during its cycle, the order of charging the materials used is quite important. The limestone flux usually is charged first, not only to protect the hearth from the impact of the solid scrap, but also to prevent the flux from entering the slag reactions until the proper stage of the process. If any ore is used, or required by the nature of the remainder of the charge, it is charged next, although ore also might be added to hasten oxidation during the later stages of the process. The scrap follows and is melted partially in the furnace if necessary to get it all in. If cold pig is used, it may be charged either with or after the scrap, but if hot pig is used, as it is in most of the tonnage produced by this process, it usually is charged through spouts placed in the charging doors after the scrap is melted somewhat and the furnace is well heated.

Such metals as *antimony*, *arsenic*, *copper*, *chromium*, *nickel*, *molybdenum*, and *tin*, which are less active than iron, can be *diluted* but not eliminated in the open-hearth process, so the composition of the scrap used is important. Antimony and tin, in particular, are avoided wherever possible be-

<sup>8</sup> See, for example, W. C. Buell, Jr., *Trans. A.I.M.E.*, 116, 1935, 77–93; E. F. Cone, *Metals and Alloys*, 7, 1936, 109–110.

cause they are deleterious to the quality of the steel, and zinc is not desirable because of the harmful effects of its oxide on the regenerators.

**MELTING THE CHARGE** In the first stages of the melting process, the solid metal, particularly the light scrap and pig iron, is oxidized by the oxidizing flame and furnace atmosphere. Thus, a mixture of molten metal and oxides will trickle down over the heavy scrap to the furnace bottom. This oxidation usually continues until the addition of the hot metal, about 2 hr after the beginning of the charging, submerges the solid material and so protects it. In general, the hot pig is added when the furnace is a little above the melting point of pig iron. However, because of the lower carbon content of the steel scrap, this still will be appreciably below the melting point of the scrap as will become evident.

After the hot metal is introduced into the furnace, it is purified as a result of the combination of the oxidizing effects of the iron oxides and the fluxing action of the limestone. These two, of course, proceed nearly simultaneously but for purposes of simplification it is convenient to consider that the oxidation cycle precedes the fluxing cycle. This is logical because, clearly, acid impurities first must be oxidized before they can be neutralized by, or combined with, the basic flux. The fact that the limestone, which was placed at the bottom of the charge, first must lose carbon dioxide by calcination before it becomes active, also tends to retard somewhat the fluxing reactions.

**THE ORE BOIL** It can be shown readily by proper chemical testing that the purification of the molten iron proceeds rapidly once it is charged into the furnace. The oxidation of the carbon takes much longer than the oxidation of the other impurities. In about 2 hr the silicon and manganese will have been oxidized nearly completely. The carbon also will have oxidized partially, resulting in the formation of carbon monoxide in tiny bubbles near the surface of the metal. These bubbles become entangled in the viscous slag, and cause it to "foam" and thus occupy much more than its normal space in the furnace. This action will be rather violent for about 2 hr more, during which time the scrap will have melted down almost completely. When the slag level has reached a point a little above the bottoms of the door openings, it is tapped off through the cinder spout into either the cinder pit or a slag pot. This tapping is known as the *runoff*. The slag so removed is composed chiefly of iron and manganese oxides, with some silica and a small amount of lime and magnesia. It represents the greatest loss in metal during the entire process, most of it in the ferrous condition.

**THE LIME BOIL** Although during the ore boil the limestone also has been calcining, the carbon dioxide so produced is in the form of relatively large bubbles and causes practically no foaming. As the carbon content of



the bath decreases, the violence of the ore boil moderates, but the calcination of the limestone becomes much more rapid. This results in the so-called lime boil, characterized by the lime rising to the top of the bath, and by a violent bubbling of the bath as a result of the rapid evolution of carbon dioxide from the decomposing limestone on the bottom. The continued oxidation of the remaining carbon merely serves to accentuate these effects. The net results of this agitation are (a) a thorough mixing of the slag and metal, thus accelerating the slag reactions and facilitating heat transfer from the hotter surface layers to the colder bottom ones, (b) direct exposure of the metal to the oxidizing influence of the flame, and (c) some oxidation of the iron and remaining carbon in the bath by the carbon dioxide passing through it.

It is during this stage, also, that the interaction between the lime and the remaining phosphate, silicate, sulfate slag takes place, forming the basic slag which is so essential to the proper functioning of the process, and that the temperature of the furnace must be increased markedly so it will remain well above the melting point of the purified metal.

**THE WORKING PERIOD** Since all the impurities except carbon have been eliminated by this time, all that remains is to regulate the properties of the slag, to adjust the carbon content and control the FeO content of the melt, and to superheat the bath to a temperature, which should be at least 300° F (150° C) above its melting range, at which it can safely be tapped. The carbon either may be brought to a low point, say 0.10%, and then raised to the desired value by recarburizing, or it may be reduced merely to a point slightly under the desired value in order to allow for the carbon in the various additions. The proper carbon content in medium- and low-carbon steels usually is secured by the first method, but with high-carbon steels either method may be used.

**THE REFINING SLAG** It is said of the open-hearth process that it does not make steel—it *makes slag*. This is essentially true, because if the slag is of the correct chemical composition and physical nature, and the temperature is right, the steel must be satisfactory.<sup>9</sup> This has been learned through experience, and verified by scientific study of the process. Thus the melter's skill is still important even with the complete technical control used today.

*Carbon, silicon, manganese, and phosphorus* must be removed from the metal as oxides; and in order to hold the latter material in the slag as a stable calcium phosphate an excess of lime, referred to as a *high lime-silica ratio*, must be maintained in the slag. Most of this oxidation is controlled solely by the iron oxide content of the slag so that, in addition to its

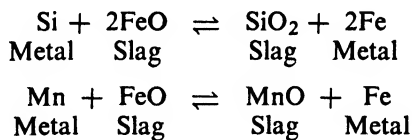
<sup>9</sup> For a complete discussion see C. H. Herty, Jr., *Trans. A.I.M.E.*, 140, 1940, 13-30.

function as a carrier of oxidized impurities, the slag also carries the refining agent. By its basicity, also, the slag affects the erosion of the furnace lining. The higher the basicity, the less the erosion; and the lower the basicity, the greater the erosion. The viscosity of the slag is also very important, and must be controlled by additions of fluorspar or burnt lime. A fluid slag is to be desired generally.

#### SLAG REACTIONS IN THE BASIC OPEN HEARTH PROCESS

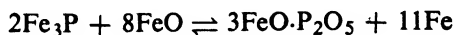
During the melting period, the slag tends to run high in iron oxide because of scrap oxidation. Consequently, when the pig iron is added, the silicon and the manganese in it are oxidized quickly, thus increasing the  $\text{SiO}_2$  and  $\text{MnO}$ , and decreasing the lime-silica ratio and the  $\text{FeO}$  content of the slag. Frequently, excess burned lime must be added to the slag at this stage to maintain the lime-silica ratio at the value desired. The slag at this point is only weakly basic, especially if a high-silicon pig is used, so severe erosion of the furnace lining is apt to result unless proper precautions are taken.

**SILICON AND MANGANESE** Oxidation of silicon and manganese may be expressed relatively simply by the equations:

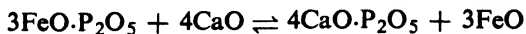


The oxides will enter the slag first as  $x\text{FeO} \cdot y\text{SiO}_2$  and  $x\text{MnO} \cdot y\text{SiO}_2$ ; but during the lime boil, these will react with  $\text{CaO}$  to form the more stable compound  $m\text{CaO} \cdot n\text{SiO}_2$ .

**PHOSPHORUS** Lower phosphorus metal tends to result from slags of increased basicity and fluidity, high  $\text{FeO}$  content, and from low temperatures of operation. The higher the phosphorus in the charge, the more difficult is the production of low-phosphorus metal, according to the typical equation:



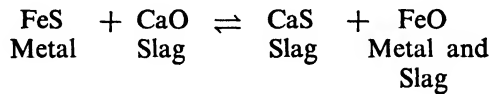
unless a slag of high basicity is used, in which case the further reaction:



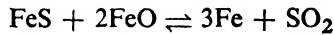
takes place. High  $\text{FeO}$  in the slag, of course, tends to increase the iron loss; but low  $\text{FeO}$  exposes the calcium phosphate to attack by manganese,

iron, or carbon, which would return the phosphorus to the metal. The FeO content, therefore, must be maintained only as high as is consistent with the phosphorus content desired in the metal.

**SULFUR** Lower sulfur tends to result from increased basicity, fluidity, and agitation of the slag, and from higher temperatures of operation. High FeO, which usually accompanies high basicity, and a high sulfur charge, make low-sulfur metal more difficult to attain because of the reversibility of the reaction:



and the inability of the reaction:



to take place because of energy considerations.

Sulfur in the furnace gases must be considered as sulfur in the charge, since the metal and slag both will absorb it until essential equilibrium is established. Frequently, there may be economic value in desulfurizing the gas so that it can remove sulfur from the metal rather than add it.<sup>10</sup> If this is done the sulfur tends to decrease in the charge and increase in the slag and gas until essential equilibrium is established.

In the usual basic open-hearth practice the slag is sufficiently high in FeO to make sulfur control more dependent on manganese than on calcium. Insoluble MnS, which tends to make the sulfur enter the slag instead of remaining in the molten metal as dissolved FeS, is formed.

**OXYGEN** The amount of dissolved oxygen in the steel before deoxidation is influenced both by the carbon content of the metal and by the FeO content of the slag. The latter factor apparently plays a major role only when the carbon is below 0.10%, and in steels in this range the oxygen content is liable to run high unless deoxidation is carried out properly.

**CARBON** Much of the carbon is burned out during the melting period, either by the FeO formed or by the ore added with the charge. However, when the heat is melted, its carbon content may be estimated from the fracture of a test bar poured from metal taken out of the furnace, and additional raw ore added, if needed, to reduce it to the desired value. During this carbon elimination, of course, the CO and CO<sub>2</sub> formed cause a boiling in the bath which serves to mix it thoroughly. The carbon elimina-

<sup>10</sup> For a further discussion of this, see E. Maurer and W. Bischof, *Journ. Iron and Steel Inst. (Brit.)*, 129, I, 1934, 123-143.

tion is followed carefully by rapid analytical methods so it is under control at all times.

#### MANGANESE AS A DESULFURIZING AGENT

The tremendous value of manganese as an essential element in steel-making arises largely from its ability to put sulfur into the less harmful form of MnS instead of FeS. Iron sulfide, FeS, is soluble in liquid iron but not in solid iron. Consequently, it tends to remain in the liquid as the metal freezes, and to separate out finally, as a low-melting film, between the crystals of the solid ingot. This results in regions in the solid metal that are relatively soft and weak at high temperatures, and thus tend to make it brittle at a red heat, or *hot-short*. Manganese sulfide, MnS, on the other hand, is not soluble in either the solid or the liquid steel and hence will tend to separate and pass into the slag as soon as it is formed. It will be found as small inclusions scattered throughout the steel, but these are relatively harmless; and, indeed, are only present because the conditions were not suitable for them to pass into the slag at the time of formation.

#### THE ACID OPEN-HEARTH PROCESS

Under normal conditions of operation, only about 1% of the steel used today is made by the acid open-hearth process. There is still considerable discussion over its relative merits in comparison with basic steel, largely with respect to its relative superiority on the basis of *cleanliness*. Cleanliness usually is judged by the number of *sonims*, i.e., solid, oxidized, nonmetallic inclusions in metals, as illustrated in Fig. 137.

The argument has been used that acid steel is superior to basic because conditions are less oxidizing during its manufacture than with basic steel. Iron oxide is found in an acid slag, largely as a silicate of iron and manganese, and the same impurities must be oxidized in the acid process as in the basic except for the phosphorus, so the difference in the oxidizing character of the conditions is probably not too great.

The open-hearth furnace used in the acid process, although usually somewhat smaller, is of the same general form as in the basic process. Because of the acid slag, the lining must be acid also, and silica is employed most frequently. This means that only *carbon*, *silicon*, and *manganese* can be removed readily by oxidation during the process; and, consequently, necessitates the use of a premium grade of pig iron and scrap which is low in both phosphorus and sulfur.

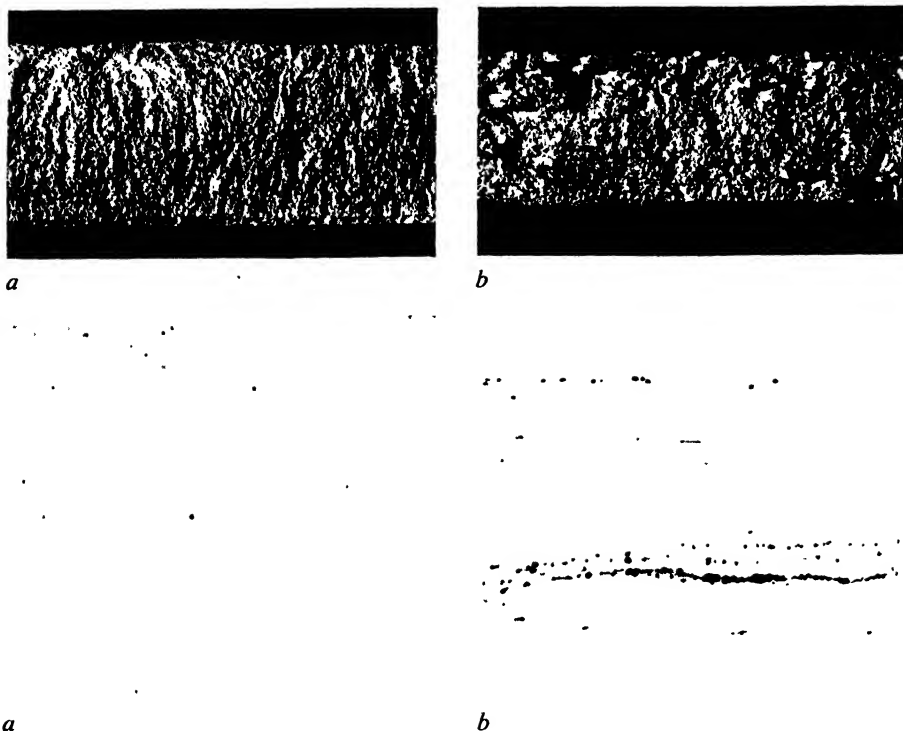


FIGURE 137. Appearance of fractures ( $\times 1$ ) and of etched metallographic structures ( $\times 100$ ) of: (a) a clean steel, and (b) a dirty steel. (From *Jalmet Notes*, the Bulletin of Associated Metallurgical Clubs of the Jones & Laughlin Steel Corporation.)

The acid slags are much easier to control than the basic slags and will analyze, on the average:

SiO <sub>2</sub>	58%
FeO	15%
MnO	21%
CaO	4%
Al <sub>2</sub> O <sub>3</sub> , Cr <sub>2</sub> O <sub>3</sub> , } about 2% or less	
MgO	

The excess of silica gives the slag its acid character.

The FeO content can be controlled closely by regulating the MnO; and, as a result, the quality of the steel can be maintained somewhat more consistently than in the basic process, unless special precautions are taken in the latter.

However, because of its inherently greater cost, largely attributable to the more expensive and less available scrap and pig, this steel is used only

for special purposes, such as armor plate and certain other ordnance applications where the additional cleanliness appears to be essential, and for the general run of steel castings. For most applications the cheaper, but probably equally good, basic steel will serve as well, and at a lower cost. )

#### CHEMICAL ANALYSIS OF OPEN-HEARTH STEELS

Unless deliberate additions of either of the two elements are made, such as would be done for the free-machining steels, it usually will be found that both the phosphorus and sulfur contents of open-hearth steels will range from 0.02 to 0.05%. The basic steels generally will fall toward the low side, and the acid steels toward the high side of these limits. This differentiation naturally results from the inability of the latter process to remove either impurity. In either acid or basic steels, the manganese could run as high as 1%, and the silicon as high as 0.30%, depending on the carbon content and the intended use. Amounts of either manganese or silicon much higher than these limits would make the steel a mild-alloy steel rather than a plain-carbon steel.

#### ( COMPARISON BETWEEN MECHANICAL PROPERTIES OF ACID BESSEMER AND BASIC OPEN-HEARTH STEELS

Figs. 138–141 illustrate the major differences between the mechanical properties of modern Bessemer (0.09% phosphorus average) and open-hearth (0.013% phosphorus average) steels<sup>11</sup> in sections of  $\frac{3}{4}$  to  $1\frac{1}{4}$  in. From these plots three facts stand out:

1. For a given carbon content the ultimate tensile strength of the Bessemer steels generally will be about 15,000 psi greater than that of the open-hearth steels.
2. In general, for a given ultimate tensile strength the Bessemer steels will tend to have somewhat higher yield points, higher percentage elongations, and slightly lower Izod impact values than the open-hearth steels.
3. As would be anticipated, with increasing ultimate tensile strengths the yield points tend to increase, and the elongation and Izod impact values to decrease for both types of steels although the rates of change differ for each.

These facts reflect the higher phosphorus, oxygen (both as dissolved and free FeO), and nitrogen contents of steels made by the acid Bessemer process in comparison with those made by the basic open-hearth process.

In addition to these mechanical properties, Bessemer steels possess good

<sup>11</sup> For a more complete discussion see E. E. McGinley and L. D. Woodworth, *Trans. A.I.M.E.*, 145, 1941, 151–158. )

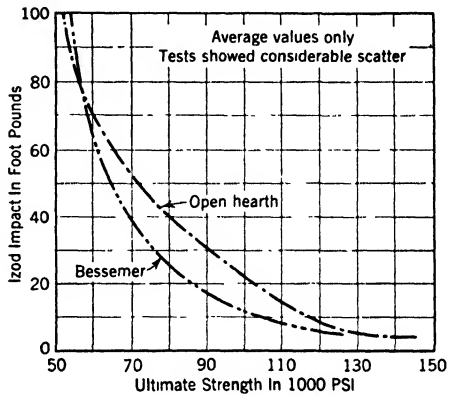
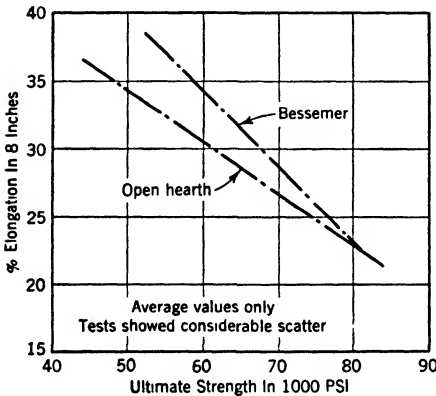
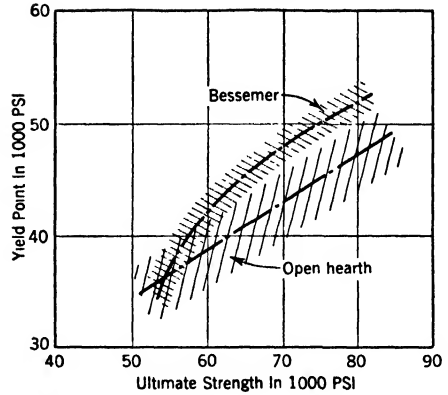
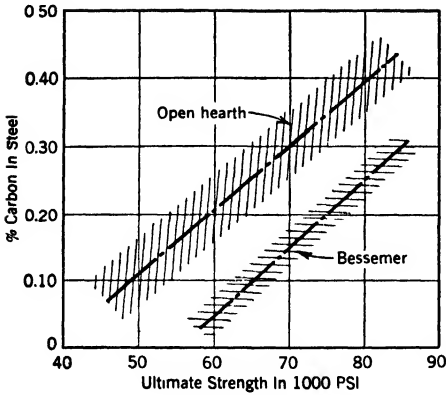


FIGURE 138. (Upper left) Comparison of ultimate tensile strengths of Bessemer and open-hearth steels of similar carbon contents. (After E. E. McGinley and L. D. Woodworth, *Trans. A.I.M.E.*, 145, 1941, 151.)

FIGURE 139. (Upper right) Comparison of ratio of yield point to ultimate strength for Bessemer and open-hearth steels. (After E. E. McGinley and L. D. Woodworth, *Trans. A.I.M.E.*, 145, 1941, 151.)

FIGURE 140. (Lower left) Comparison of elongations of Bessemer and open-hearth steels for equivalent ultimate strengths. (After E. E. McGinley and L. D. Woodworth, *Trans. A.I.M.E.*, 145, 1941, 151.)

FIGURE 141. (Lower right) Comparison of impact strengths of Bessemer and open-hearth steels for equivalent ultimate strengths. (After E. E. McGinley and L. D. Woodworth, *Trans. A.I.M.E.*, 145, 1941, 151.)

weldability, machinability, and resistance to bending, all properties which explain their widespread use for applications such as skelp for small butt-weld conduit, automatic screw-machine steels, tin plate, and galvanized sheets. )

INGOT IRON

The basic open-hearth process which is used in making ingot iron, the present commercially pure grade of iron, does not differ greatly from that

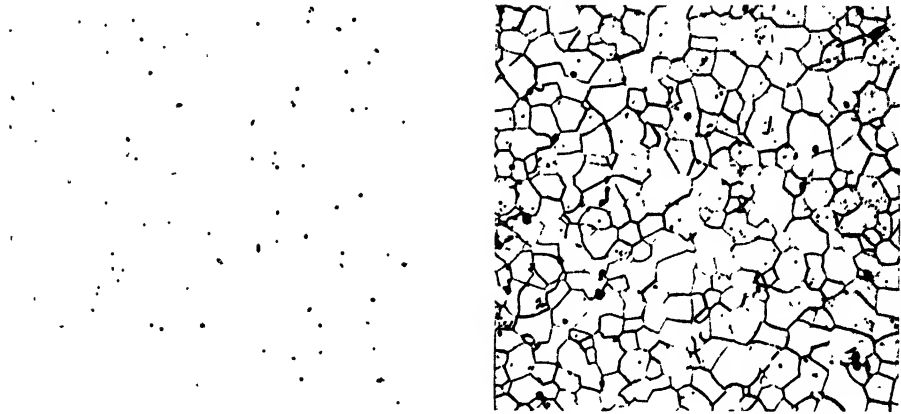


FIGURE 142. Metallographic appearance of ingot iron showing numerous inclusions of iron oxide.  $\times 100$ . (Left) Unetched. (Right) Etched with nital.

described above. However, because of the greater purity of the iron, the temperature must be appreciably higher toward the end of the refining process; and the wear on the furnace will be, therefore, much greater. It is also obvious that the extent of the oxidation must be much greater in order to effect almost complete removal of the impurities present; and that, as a result, the resulting iron is apt to be quite high in iron oxide, free particles of which are shown metallographically as inclusions in Fig. 142. Although deoxidation will help to reduce this excess iron oxide to some extent, it is not feasible to reduce it to the order of magnitude usually found in steel. A typical American ingot iron will analyze 0.015% C–0.020% Mn–0.005% P–0.035% S–0.005% Si–rem. Fe, and is guaranteed to contain less than 0.16% total impurities. The oxygen content may run as high as 0.10% depending on the particular practice used, but this usually is not considered as an impurity in this material.

#### DUPLEXING

Frequently, metal to be refined in the basic open-hearth furnace first is blown in a Bessemer converter to remove the silicon, manganese, and carbon; and then poured into the basic open-hearth furnace for removal of phosphorus and for oxygen control. This combination of refining processes usually is referred to as *duplexing* although the term could be used to refer to any steelmaking process in which two of the usual refining methods are combined. Similarly, the combination of three refining processes, although it is done infrequently, would be known as *triplexing*. )

In certain steel plants, especially those in the South, such combination processes have many advantages over the standard methods. The in-



frequent use of the Bessemer process and the improvements in the basic open-hearth process in recent years have militated against the more widespread use of these combined processes, although duplexing not only allows a greater tonnage of metal to be produced in a given time than is possible with standard practices, but also permits the use of much less scrap than is needed commonly. The accompanying disadvantages, however, offset these to some extent under normal operating conditions.

#### BASIC ELECTRIC STEEL

An arc furnace of the Heroult type (Figs. 79, 80, and 81) is used most commonly for the electric-furnace refining of steel. Usually, this is run in one of three ways:

1. *Cold melt, full refining, process.* Scrap metal is used and the complete purification is carried out in the furnace.
2. *Cold melt, finished under a reducing slag, process.* A carefully selected low-phosphorus scrap is used so that the process is largely for melting, and only some of the other impurities must be removed.
3. *Hot metal process.* Hot metal, which already has been dephosphorized, is tapped from the basic open-hearth furnace and *superrefined* in the electric furnace. This method of operation would be, of course, a form of duplexing.

Since all three processes involve the same general principles, only the most complete, viz., the first, will be described.

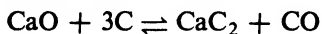
#### IMPURITY REMOVAL IN THE BASIC ELECTRIC PROCESS

All six of the impurities commonly found in steels, viz., *carbon, silicon, manganese, phosphorus, sulfur, and oxygen*, can be removed satisfactorily in the basic electric process. However, inasmuch as the first four of these require an oxidizing slag, and the last two can be removed with certainty only under reducing conditions, certain complexities are introduced at once. For the optimum removal of all of them, however, a basic slag is desirable. The most obvious solution to the problem is to use two slags, one oxidizing and one reducing, and this is the usual procedure. The ability of the electric furnace operator to employ any desired kind of slag at will is one of the chief advantages of the process.

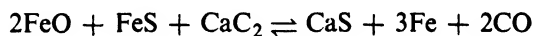
For fluxing purposes, either limestone is added with the scrap charge or else a certain amount of fluorspar, burned lime, and sand is added after the charge is molten. This, together with the iron oxide formed during melting and with a certain amount of ore which may be added if necessary, forms the base for the first, *oxidizing or black, slag*. Because of the reaction

of the FeO with the liquid scrap, and of the high basicity of the slag, it will oxidize and hold the oxides of most of the silicon, manganese, and phosphorus present, the oxides of carbon, of course, going off in the gases. In the electric furnace a means of positive temperature control is available, and hence it is possible to keep the temperature low to oxidize the other elements before all the carbon is removed. This helps to prevent the absorption of an excessive amount of oxygen by the liquid metal during the first refining stage.

The black slag must be removed once its work is completed, for, if it were made reducing, the phosphorus compounds would be reduced and the phosphorus would go back into the steel. The first slag, therefore, is replaced by a second slag, composed of lime, fluorspar or sand, and coke, which will be both basic and reducing in character. The purpose of the fluorspar or sand is merely to control the fluidity of the slag. This slag will contain some calcium carbide, also, because of the interaction of the lime and carbon at the temperature of the furnace:



The second, *reducing* or *white, slag* is kept in contact with the bath for 2 hr at the most. In that time, it will react with the steel, removing both sulfur and oxygen according to the equation:



The calcium carbide removes the oxides from the slag first. According to the laws of chemistry, a definite ratio always must be maintained between the oxides in the slag and those dissolved in the steel bath. Hence, the removal of oxides from the slag will result in the passage of oxygen from the steel to the slag, in order to restore this ratio. It can be comprehended readily, however, that such a process never can remove the oxygen from the steel completely. A small residual amount always must remain to maintain the ratio.

Freedom from inclusions is assured in the electric process if the metal is held in the furnace during the finishing period at high enough temperatures, and for long enough times, to permit the inclusions to rise to the surface and enter the slag. In the other steelmaking processes, various features of operation all require specific deoxidation practice, and tend to prevent such a procedure.

When the composition is adjusted properly, and the correct pouring temperature is secured, the furnace is ready for tapping. A comparatively narrow range of pouring temperatures always is advisable in tapping any molten metal, because the solubility of gases in liquid metal tends to

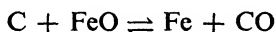
increase markedly with increased temperature above the melting point, and these gases, with the possible exception of hydrogen,<sup>12</sup> will be given off again as the liquid metal solidifies in the mold.

#### ACID ELECTRIC STEEL

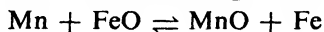
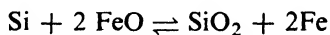
The acid electric process, which usually is considered to be unsuitable for making steel ingots because of its inability to remove either phosphorus or sulfur, is used widely for making steel castings; and, in many cases, for cast irons, especially those of the alloy variety. The melting time is much shorter than in the basic processes because, usually, only a minimum of refining is carried out. High temperatures are obtainable without undue refractory trouble; and thus high fluidity can be secured in the metal to be cast. The slag is handled easily, thereby reducing slag inclusions in the castings. This cleanliness and uniformity are decidedly advantageous when castings are to be machined, as inclusions in steel are apt to accelerate the wear of cutting tools.

In the acid electric process used for steel castings 50–60% of the charge is scrap from the steel foundry itself, and the rest of it usually is metal scrap, preferably in the form of plate, turnings, or punchings. Thin or rusty scrap is not desirable because of the oxygen it introduces. Phosphorus and sulfur must be kept low because they cannot be removed.

Most of the reaction is between the carbon in the steel and the FeO formed on melting:



although silicon and manganese are oxidized also and pass into the slag as  $x\text{FeO} \cdot y\text{SiO}_2$  and  $x\text{MnO} \cdot y\text{SiO}_2$ .



The furnace usually is tapped after proper deoxidation and temperature adjustments have been made.

#### *The Ingot Stage of Steel Production*

Steel made by any of the above processes will have certain limitations regarding normal impurity content which are inherent in the chemistry, acid or basic, by which it was made. It also will have certain limitations in oxygen content which will be characteristic of the process, i.e., Bessemer,  
<sup>12</sup> See, C. Zapffe and C. E. Sims, *Metals and Alloys*, 11, 1940, 145–151, 177–184; *ibid.*, 12, 1940, 44–51, 145–148.

open-hearth, electric, crucible, etc. One of the most important phases of steelmaking, especially with reference to the efficient use of steel in engineering, depends upon the treatment given to the molten metal before it is poured into the ingot mold. It is here that the factors are controlled which will determine the *austenitic grain size* and hence the uniformity and reproducibility of the resulting steel.<sup>13</sup>

#### DEOXIDATION

Deoxidation is essentially the removal of oxygen from the steel<sup>14</sup>, and is one of the most important stages of the finishing operation. Deoxidation can be carried out in the furnace, the ladle, or the mold, depending on the specific conditions obtaining.

In the furnace the bath is relatively shallow and any nonmetallic matter formed will have a smaller distance to travel to reach the slag than in the ladle or the mold. Thus a better quality, i.e., cleaner, steel probably will result. Less holding time after deoxidation also will be required, because of the shorter distance; and since a source of heat is available, a better temperature control is possible during this stage. However, in the furnace, there is also a greater surface of contact between the slag and the metal, and more oxide can pass from the oxide-richer slag back into the metal, thus reoxidizing it. It is usually not feasible, except in the electric furnace, either to remove the refining slag or to replace it.

In basic processes, too, since the slag usually runs high in phosphorus, deoxidation in the presence of the slag is likely to put phosphorus back into the metal. However, in any acid process, deoxidation can be carried out in the furnace. The resulting steel is somewhat more liable to be cleaner than that made by a basic process, if the other conditions are the same, because the oxide particles formed by deoxidation will have more opportunity to rise to the surface and enter the slag. This is one of the principal advantages of acid steel.

Usually one or more of three deoxidizers are used: *manganese*, *silicon*, and *aluminum*, the first two generally being used in the form of their ferroalloys as mentioned previously. Their relative deoxidizing powers at 2900 F (1600 C) can be appreciated best from Fig. 143. Additions of ferromanganese generally are made in the furnace, possibly with some ferrosilicon, but more frequently alone. Manganese serves more as a desulfurizer to get the sulfur into the comparatively harmless form of MnS than it does as a de-

<sup>13</sup> See, for a further discussion, S. Epstein, J. H. Nead, and T. S. Washburn, *Trans. A.S.M.*, 22, 1934, 942-978.

<sup>14</sup> See C. H. Herty, Jr., *The Deoxidation of Steel*, Bull. No. 69, 1934, Min. and Met. Adv. Boards, Pittsburgh, Pa.

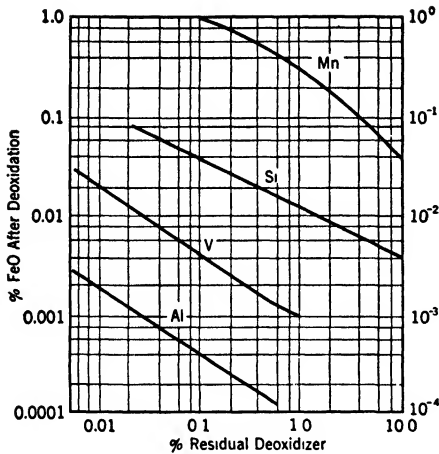


FIGURE 143. Comparison of deoxidizing powers of various metals in steel at 2900 F (1600 C). (After John Chipman.)

metal during the pouring of the previous ingots. Because of their mold deoxidation, however, these ingots frequently are not considered to be of first class.

#### SHAPE OF INGOT MOLDS

Two general types of top-poured ingot molds are in common use in the United States, the *big-end-up* and the *big-end-down*. Many plants also use bottom-poured ingots, and some tool steel makers use a so-called winged ingot. These types are illustrated in Fig. 144.

To understand the difference between the two main types used for top pouring, the conditions existing during solidification must be reviewed. In general, solid metal occupies a smaller volume than the liquid metal from which it was formed. In the process of solidification, the first portion of liquid to freeze is that immediately adjacent to the mold surface, i.e., that from which the heat is removed first. At this early stage in solidification, the mold is full of molten metal, and this solidified skin covers the entire surface between the metal and the mold. As solidification continues, the volume of the metal decreases; finally, when solidification is complete, the level is considerably lower, thus producing a chimney or *pipe* in the center of each ingot. The general process of solidification can be followed more easily from the various stages of the process illustrated in Fig. 145. The principles involved remain unchanged, even though, in making these pictures, wax was used instead of steel.

In a big-end-up ingot, the larger volume of metal is at the top, where

oxidizer. In the ladle, ferrosilicon is added, and usually some aluminum also, just before pouring. More aluminum frequently is added in the molds, although, if a good quality steel is desired, this form of deoxidization should be kept to a minimum. In the best steelmaking practice, mold deoxidation is not recommended; usually the only time that it is used at all is for the last six or so ingots poured from a large ladle. Under such circumstances, the aluminum serves to compensate, to some extent, for the oxygen picked up by the ladle of molten

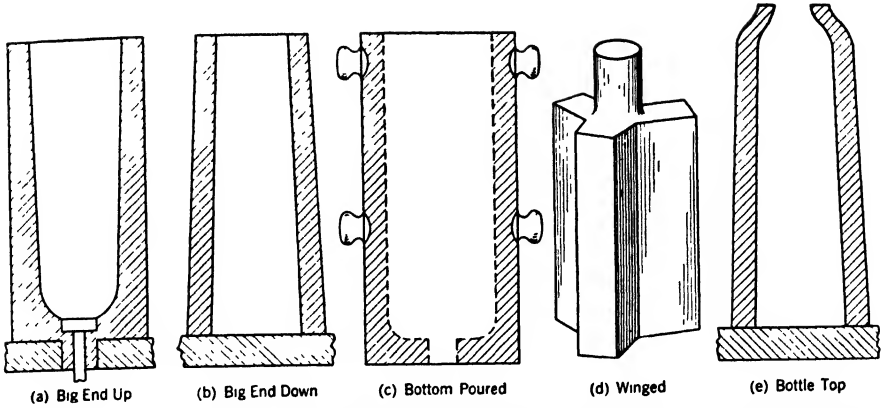


FIGURE 144. The five common types of ingot molds. *a.* Big-end-up. *b.* Big-end-down. *c.* Bottom poured. *d.* Winged. *e.* Bottle-top. The first three are used the most widely, the last two being used only for special purposes. For simplicity a winged ingot is shown rather than the mold in which it was poured.

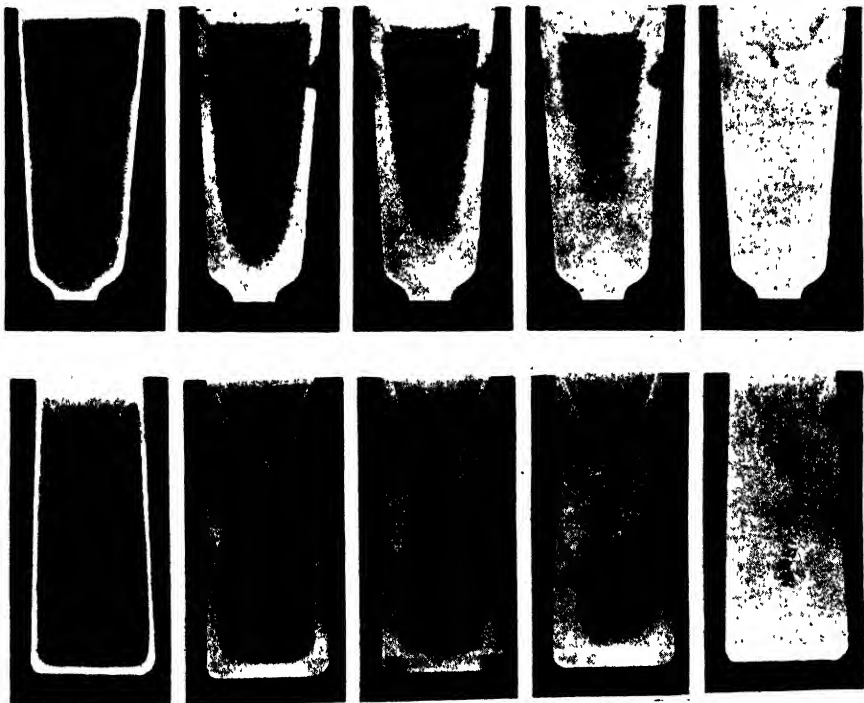


FIGURE 145. Various stages in the solidification of wax ingots in big-end-up (*upper*) and big-end-down (*lower*) ingot molds. (From *The Ingot Phase of Steel Production*, courtesy The Gathmann Engineering Company.)

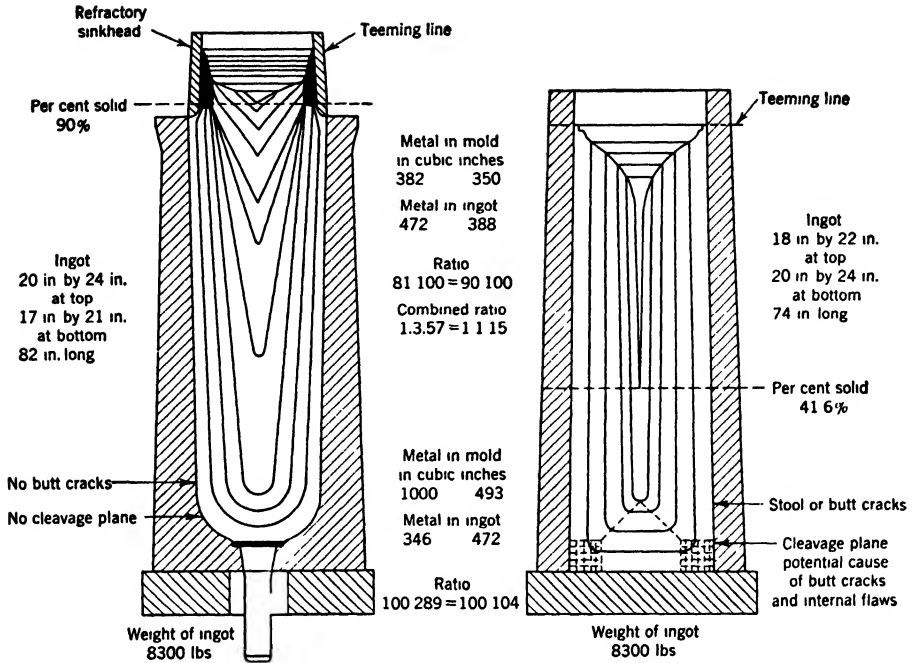


FIGURE 146. Schematic illustration of pipe formation in big-end-up and big-end-down ingots as shown by solidification curves. (From *The Ingot Phase of Steel Production*, courtesy The Gathmann Engineering Company.)

it remains molten longest. Consequently, the pipe tends to be less than in the big-end-down ingot where the larger volume is in the lower half.

#### METHODS OF PREVENTING PIPE FORMATION

Two general methods are in common use for minimizing pipe formation in ingots. The first involves a simple compensation for the difference in volume between the liquid metal and the solid metal. During the various stages of solidification of the ingot, additional liquid metal is added in order to keep the mold as full as possible. This naturally will tend to compensate for the shrinkage but is somewhat time consuming. The second method involves the use of a refractory addition to the top of the ingot mold, called a *hot top*. These hot tops not only tend to slow down the process of solidification because of their lower heat conductivity, but also tend to raise the effective height of the metal in the mold, and, thereby to decrease the effective depth of the ingot pipe. In other words, although a pipe may be formed and cropping of the ingot may be required, a much greater useful length of the ingot will result with a hot top than without it. This is illustrated in Fig. 146. The use of hot tops adds appreciably to the cost.

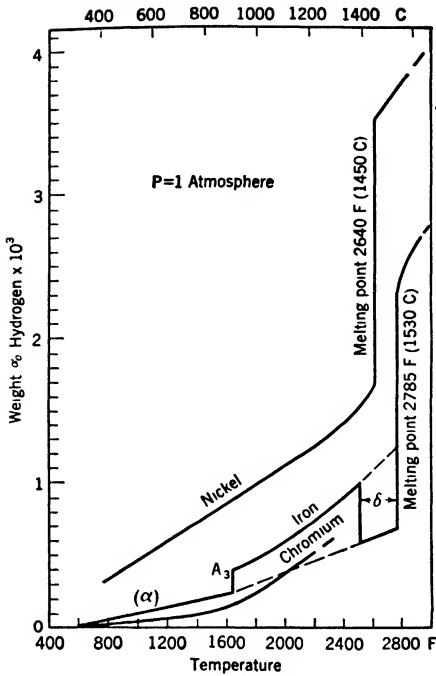


FIGURE 147. (Left) Solubility of hydrogen in iron and nickel (after Sieverts) and in chromium (after Luckemeyer-Haase and Schenck, and Martin) for a pressure of 1 atm. (From C. A. Zapffe, *Trans. A.I.M.E.*, **154**, 1943, 283.)

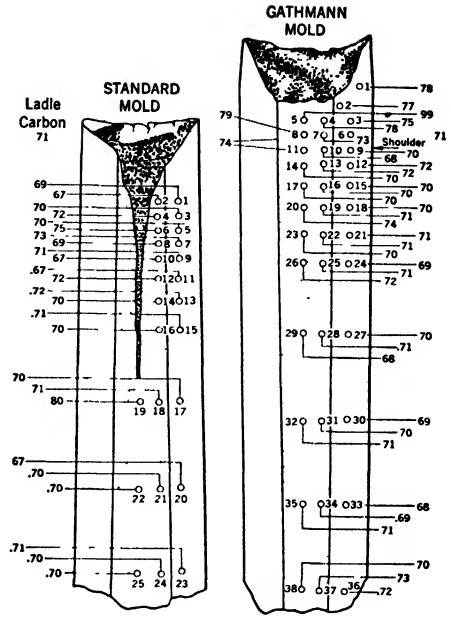


FIGURE 148. (Right) Segregation of carbon in a fully deoxidized ingot as shown by chemical analysis. (From *The Ingot Phase of Steel Production*, courtesy The Gathmann Engineering Company.)

The exact method of deoxidation used also will have a pronounced effect on the character of the pipe produced during solidification.

GAS EVOLUTION DURING SOLIDIFICATION

The solubility of gas in molten metal, contrary to its solubility in most liquids, is much greater than in solid metal. This is illustrated in Fig. 147 for hydrogen in iron, nickel, and chromium, but similar effects are found for most other examples. As a result, there is a large evolution of gas from the molten metal as it solidifies. This gas frequently cannot escape, either because the metal already has solidified, or because it is too viscous. Consequently, it is entrapped, forming internal cavities, called *blowholes*, similar to those shown in Fig. 151. If the inside of such a hole is oxidized, it becomes a permanent defect, but as long as reducing conditions obtain, it usually is believed that it will weld up during subsequent hot-working.



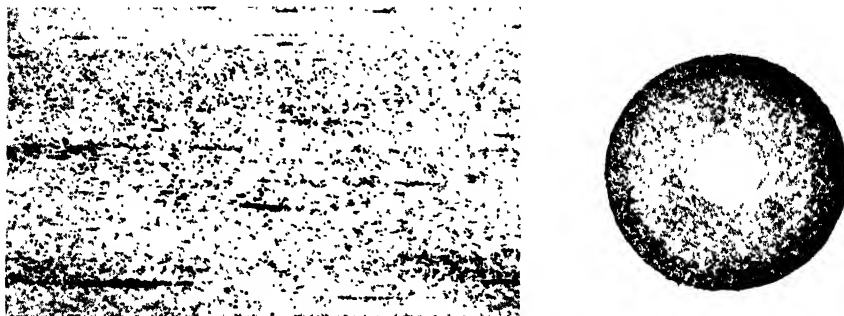
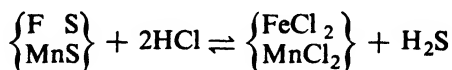


FIGURE 149. Sulfur prints made on the longitudinal section (*left*) and the cross section (*right*) of two steel bars. The white spot is the result of a lathe centering hole.

### SEGREGATION

Another difficulty also may arise because of the manner in which liquid metal solidifies. Usually, and for reasons that will be understood better later, the more impure a metal is, the lower will be its freezing point. Consequently, as the liquid solidifies, certain impurities, such as phosphorus, sulfur, and carbon, tend to segregate in the liquid metal, and to appear in the finally solidified ingot as enriched areas in the last portion to solidify, usually the center of the ingot.<sup>15</sup> In the big-end-up ingot, this region tends to lie in the upper part of the ingot, which usually is cropped as scrap; but in the big-end-down ingot, the greater segregation tends to lie in the center of the lower half of the ingot, which was the last to freeze. In the so-called winged ingot both the pipe and any segregation tend to fall in the central portion, leaving the smaller wings essentially sound and uniform.

The results of segregation are illustrated in Fig. 148, for carbon, as shown by chemical analyses made at various locations in the ingot; and, in Fig. 149, for sulfur, as disclosed by a *sulfur print*. These prints are made<sup>16</sup> by placing firmly in contact with the clean, flat, ground metal surface a piece of photographic paper that has been soaked in dilute (1–2%) hydrochloric acid. The acid reacts with iron or manganese sulfide:



liberating hydrogen sulfide gas. This, in turn, attacks the silver salts in the paper precipitating dark silver sulfide, which shows up clearly on the white background. By fixing the paper photographically, general darkening is

<sup>15</sup> See, for example, J. W. Halley and T. S. Washburn, *Trans. A.I.M.E.*, **131**, 1938, 195–205.

<sup>16</sup> See H. B. Pulsifer, *Inspection of Metals*, Amer. Soc. for Metals, Cleveland, Ohio, 1941.

prevented. Similar tests are available for determining phosphorus segregation.<sup>17</sup>

#### EFFECT OF DEOXIDATION PRACTICE ON METAL PRODUCED

It is a metallurgical axiom that *no metal can be sounder than the ingot from which it is produced*. Depending upon the degree of deoxidation, four general methods are employed commonly to control soundness, giving what are termed *killed, semikilled, rimmed, or capped steel*. Only the first three of these, the effects of which are illustrated schematically in Fig. 150, are of much commercial importance.

**KILLED STEEL** In killed or piping steels, the essential quality desired is soundness, i.e., freedom from blowholes and segregation of impurities, because definite strength factors are required. Steels of any carbon content can be and sometimes are killed, although most killed steels contain more than 0.25% carbon. However, large tonnages of killed low-carbon sheet steel are produced for deep-drawing applications.

In killed steel, the deoxidation, although not complete, is sufficiently so that there is essentially no evolution of gas during pouring and solidification. The top surface lies quietly, and the ingot solidifies relatively rapidly. Strong deoxidizers, such as ferrosilicon and aluminum, are used to accomplish this result, and the metal should be held quietly for 10–20 min after adding the deoxidizer to ensure proper mixing and elimination of nonmetallic material. The time factor depends, naturally, on whether the maximum deoxidation is carried out in the furnace or the ladle.

**SEMIKILLED STEEL** In semikilled steel, the deoxidation is only partial. Ferromanganese usually is added in the furnace as a desulfurizer, but it accomplishes some deoxidation also. Then either ferrosilicon or aluminum, or both, is added in the ladle; sometimes aluminum also is added in the mold. Solidification is fairly quiet, but the resulting metal is neither so sound nor so dependable a material as killed steel for the most severe engineering applications.

**RIMMING STEEL** Because of the difficulty and expense involved in making a clean, low-carbon, fully deoxidized steel ingot, recourse is sometimes made to a process called rimming. The steel is partially deoxidized to such an extent that, as it begins to solidify, there is a brisk evolution of gas at or near the interface between the solid and liquid metal. This tends to force the impurities toward the still molten center and keeps the top of the ingot open until a layer, 2–3 in. thick, of fairly pure iron has had a chance to form. This surface layer is quite dense. It is true that numerous blowholes remain in the ingot after it solidifies, but they usually are found

<sup>17</sup> See H. B. Pulsifer, *ibid.*

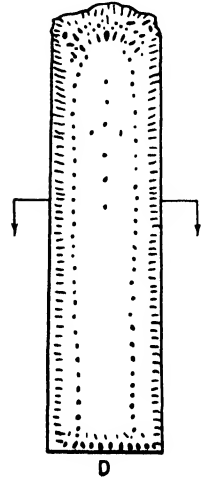
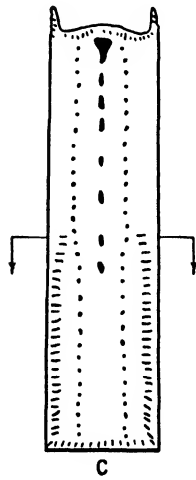
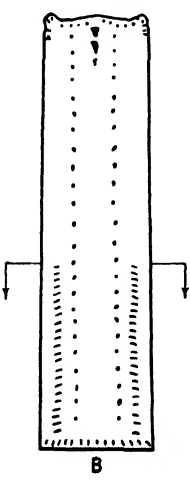
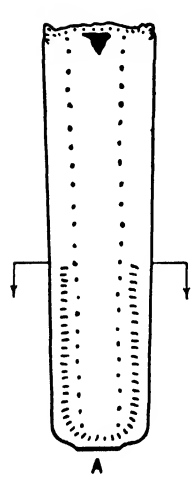
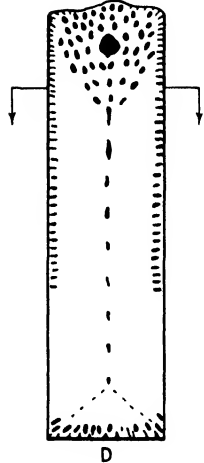
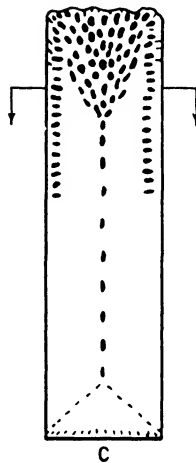
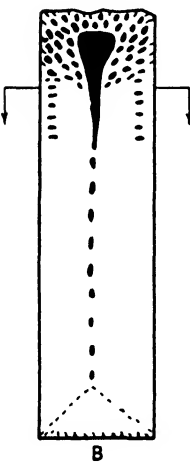
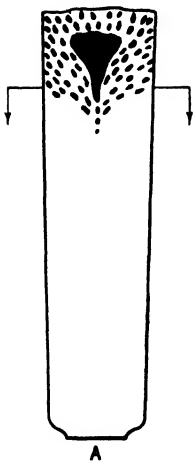
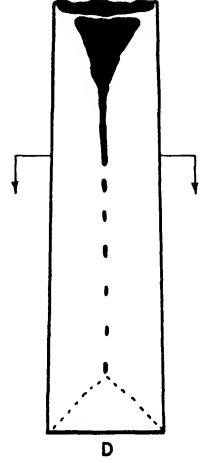
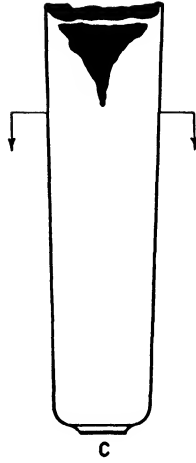
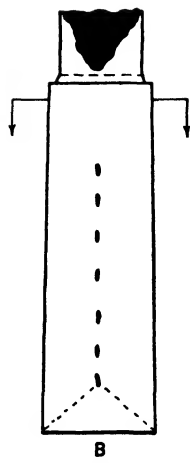
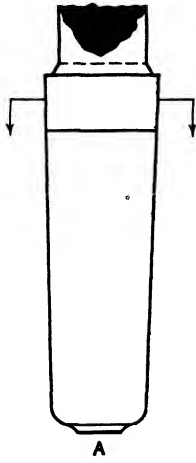




FIGURE 151. Actual cross sections of rimmed steel ingots. (Left) Big-end-up. (Right) Big-end-down. (From *The Ingot Phase of Steel Production*, courtesy The Gathmann Engineering Company.)

either in the center of the ingot or in a layer just under the relatively pure iron skin. Consequently, they are welded easily up during the subsequent hot-work because their surface should not be oxidized. A cross section typical of a rimmed steel ingot is indicated in Fig. 151. The absence of a pipe is noticeable. The volume occupied by the internal blowholes replaces it.

FIGURE 150. Schematic illustration of the interior physical condition of big-end-up and big-end-down ingots produced by the three common methods of deoxidation, fully killed (*top*), semikilled (*middle*), and rimmed (*bottom*). (From *The Ingot Phase of Steel Production*, courtesy The Gathmann Engineering Company.)

The rimming action is obtained by a close control over the iron oxide content of the slag, the slag viscosity, the pouring temperature, and the deoxidizers used. Steels containing more than about 0.30% carbon cannot be made to rim at all, and the method is not employed usually with steels containing more than 0.15% carbon. Specific practice may, and often does, vary for different steel companies.<sup>18</sup>

**CAPPED STEEL** Capped steel is made by a relatively few companies, producing ingots whose surface approaches that of rimmed ingots. The metal is cast into a *bottle-top* mold (Fig. 144e), and the top is then covered with a cap which fits neatly into the bottleneck of the mold. This causes the top metal to solidify rapidly, and stops all rimming action by trapping the gases. However, the internal pressure set up in the center of the ingot during final solidification results in a surface approaching that of rimmed steel.

#### FACTORS AFFECTING THE TYPE OF DEOXIDATION USED

The application for which the steel is intended determines, as a rule, the deoxidation practice that is used. Steels of the highest quality, and especially those which are to receive extensive machining or other operations entailing relatively high labor charges, usually are made of killed steel. Likewise, steels in which dependability is essential, such as those in which reproducibility is required, or from whose failure loss of life or serious property damage might result, usually are made of killed steel. Cold-forming steels, in which the reduction in the draw is more than about 35%, also must be made of killed steel because the other grades will not stand such treatments without excessive failure. The economic factor always must be considered because the killed steels are usually specification steels of premium grade. Their use is justified only when the other grades will be unsatisfactory because of inconsistency or because of excessive failure or chance of failure, either in the working operations themselves or in their use after fabrication.

The semikilled steels make up the large class of materials in which no special precautions need be taken, and which are intended for no particularly important application. Where defects are not important and dependability is not particularly required, the semikilled grade of steel will do nicely at a comparatively low cost.

Rimmed and capped steels have been used largely because of the excellent surface which they possess by virtue of their comparatively pure iron skin. For this reason, they have, until recently, been used widely in places where workability was the principal consideration. Parts made of them will

<sup>18</sup> See, for example, J. H. Nead and T. S. Washburn, *Metals and Alloys*, 5, 1934, 43-47.

finish up easily, requiring only one or two coats of paint or some similar material. The automotive industry, in particular, used comparatively large quantities. However, where forming operations requiring more than about 35% reduction are used, as in some designs for deep-drawn fenders, it has been found that the rimmed steels are apt to run excessively high in scrap because of rejects from surface imperfections. Consequently, in most of these applications it has been necessary to go over to the killed grade of steel, even though the metal cost is somewhat higher. It should be pointed out in this instance, in particular, that the metal cost is not the only determining factor. This is often true. A higher priced metal that will give a lower percentage of failures or rejects may, in the final analysis, be the cheaper material to use.

#### DEFECTS ORIGINATING IN THE INGOT STAGE

A brief mention already has been made of three of the more common irregularities in the ingot stage which ultimately result in defects in the final steel product.

**SEGREGATION** Segregation of impurities, such as phosphides for example, in the ingot tends to give, in the hot-worked steel, banded structures similar to those shown in Fig. 461*b*. Although once formed no subsequent heat-treatment will eliminate this type of segregation completely, a slow rate of cooling of the heat-treated or hot-worked steel seems to bring it out more clearly than a more rapid rate. The exact reason why carbon segregation should be controlled, as it seems to be, by segregation of other impurities by no means is understood completely. The major trouble traceable to segregation is uneven response to mechanical or thermal treatment.

**PIPE AND BLOWHOLE FORMATION** Pipe formation and blowhole formation are related somewhat as indicated previously. The more complete the deoxidation, as in killed steels, the greater the tendency for pipe formation and the less the tendency for blowhole formation. Conversely, the less complete the deoxidation, as in rimming steels, the less the tendency for pipe formation and the greater the tendency for blowhole formation.

Although the efforts of the steel mills are directed toward cropping enough of the ingot essentially to eliminate the pipe, this cannot always be done completely, as a pipe, or other shrinkage defects, may disappear and then reappear farther along in the ingot. The surface of a pipe is oxidized to some extent usually, and hence there is little tendency for it to weld up during hot-working. In rod or wire products this may result in a fine hole or porous region running down the center of the piece. In sheet

or plate products it tends to lead to *laminations*. These are particularly disturbing in welded structures such as tanks, etc., since their size and position in the plate may exert a marked effect on the ability of the structure to withstand the stresses for which it was designed. In general, these laminations are not structurally dangerous unless they come out to the surface of the plate at one or more spots.<sup>19</sup>

Blowholes, as mentioned previously, generally weld up during hot-working as long as their surface is not oxidized, a state which usually exists. Occasionally, however, blowholes near the surface will be exposed to the atmosphere and their surfaces will become oxidized. During subsequent working these tend to form small laminations or seams which are, however, not nearly so important because of their size as those resulting from internal shrinkage defects.

Defects of either of these types are extremely difficult to detect because the two parts are generally in close contact, even though not welded, and their possible emergence on the surface is apt to be thoroughly hidden by mill scale. Heating usually will show them up because of differential expansion. This is one reason why they frequently are found during welding operations.

**INCLUSIONS** Slag or other inclusions generally are considered to be indications of dirty steel as illustrated in Fig. 137. The principal objections to these inclusions probably lie in their weakening action as possible stress raisers. In addition, large slag inclusions may be the cause of blistering in finished products that have been pickled in acid.

**INGOTISM, CLEAVAGE, CRACKS, AND CHECKING** The general shape and condition of the ingot molds may affect profoundly the presence of defects in the steel. Since the ingot cools fairly slowly from the liquid state the tendency is for columnar crystals to grow perpendicularly in from the mold walls.

This condition may result in the formation of "planes of weakness," as illustrated in Fig. 293. Defects such as these are quite likely to result in cracking during working but they can be eliminated by proper modification of the mold contour, such as rounding the corners more generously, for example.

Unduly large crystals, a condition known sometimes as *ingotism*, also make the ingot liable to tear or crack in rolling because of the weakness of the bonding between the crystals. It is largely for these reasons that the first reducing passes in working an ingot are kept light. Once hot-work, or cold-work and annealing, has had a chance to recrystallize the coarse

<sup>19</sup>The general subject of "Laminations in Welded Steel Plates" is well discussed by F. L. Goldsby, *The Iron Age*, February 15, 1945, 66-69.

structure thoroughly, the amount of deformation can be increased safely.

If the surface of the ingot mold is very rough or contains cavities so that resistance is offered to the natural contraction of the steel, either transverse or longitudinal cracks may result, depending upon the manner in which the restraint is imposed. Transverse cracks are the more common of the two. These cracks invariably become oxidized and, unless removed by grinding or chipping, will appear as seams in the final product.

**SCABS** Similar seamy products may result from improper pouring conditions. Molten metal may splash against the sides of the cold mold and solidify there, almost always with an oxidized surface. As the liquid metal rises around these regions, they form what is actually a metallic surface inclusion, usually called a scab. If the scab is large, it may appear in the finished product as a form of lamination. Smaller scabs, if not removed, usually are classed as laps, seams, or slivers in the final product. These pouring defects, of course, can be completely eliminated by bottom pouring but there are so many other disadvantages to this method that it is not used frequently. Instead, careful control of the teeming or pouring is established with good nozzles and stoppers in the ladle to keep such defects to a minimum. Mold washes of various types also will assist in preventing them but these tend to disturb the solidification conditions and the formation of a solid skin so that, in high-quality steel, they usually are avoided.

#### PREVENTIVE MEASURES

It must be emphasized that the steel mills take every precaution possible to prevent these defects from appearing in the final product. Ingot cropping, surface grinding and chipping, and frequent inspections all are used to maintain the quality of the product at the highest possible level. However, in spite of the care taken, a very small percentage does appear in the finished products, principally because of the difficulty in detecting certain types of defects. As might be anticipated, these are more apt to be overlooked in hot-rolled than in cold-rolled products simply because finish inspection of any hot-worked product is complicated greatly by the presence of oxide on the surface.

#### *For Further Study Refer to*

1. *The Making, Shaping, and Treating of Steel*, 5th ed., by J. M. Camp and C. B. Francis: Carnegie-Illinois Steel Corp., Pittsburgh, Pa., 1940.
2. *Metals Handbook*: American Society for Metals, Cleveland, Ohio, 1939 (usually published triennially). A new edition will appear in 1948.



3. *Metallurgy of Iron and Steel*, 4th ed., by Bradley Stoughton: McGraw-Hill Book Company, Inc., New York, 1934.
4. *Ferrous Metallurgy*, by E. J. Teichert: McGraw-Hill Book Company, Inc., New York, 1944.
5. *Symposium on Steelmaking*: The Iron and Steel Institute, London, 1938 (English practice in this field).
6. *Wrought Iron*, 2d ed., by J. Aston and E. B. Story: A. M. Byers Co., Pittsburgh, Pa., 1939.
7. *Ingot Contour and Its Relation to Sound Steel*: The Gathmann Engineering Co., Baltimore, Md., 1930.
8. *Transactions American Institute of Mining and Metallurgical Engineers*, Iron and Steel Division: A.I.M.E., New York (published annually).
9. *Basic Open-hearth Steelmaking*: A.I.M.E., New York, 1944.

## VII Production of the Metals— Copper, Nickel, Lead, and Tin—from Their Ores

THE IMPORTANT ENGINEERING METALS COPPER, NICKEL, LEAD, and *tin* are less active chemically than iron. However, because of the other impurities present in their ores it is still not simple to produce metal of a satisfactory commercial purity without undue metal loss. In general, the methods of production will be either *pyrometallurgical*, involving as a rule first a reduction and then a refining stage, or *electrolytic*, either by cathodic deposition from solutions of the ores using insoluble anodes, or else by solution from partially refined soluble anodes and redeposition on pure cathodes. The particular processes which are in commercial use for each metal depend upon numerous economic factors which cannot be gone into in detail here.

### *Copper*

#### COPPER ORES

The United States is the world's largest producer of copper, followed in order by Africa (Belgian Congo and Rhodesia principally), South America (Chile and Peru), Canada (largely from codeposits with nickel), and the U. S. S. R. In this country Arizona, Utah, Montana, Nevada, Michigan, and New Mexico are, in order, the largest producers.

Even though ore bodies containing as high as 20–25% copper have been mined, the United States ores usually average only about 1% copper. On the other hand, the African ores run higher than 4% in some deposits, and even the Chile ores exceed 2%. The combination of richer ores and cheaper labor has proved to be a serious competitive factor aiding the foreign ores. Because of these lower production costs, a 4-cent per pound protective tariff on all imported copper has been in effect for several years.

The principal ores of copper are, essentially, either *native*, *oxide*, or *sulfide*.

**NATIVE ORES** The deposit of native copper found in the upper peninsula of Michigan is unique, no comparable deposit being known anywhere. These ores average 1% copper although some "nuggets" as large as 400 tons have been found. By using water-gravity methods, concentrates containing 40–70% copper can be secured.

The Michigan ores contain on the average 0.7 oz of silver per ton (1 oz per ton = 0.00343% silver), an amount too small to remove economically. The presence of a small amount of silver, therefore, is characteristic of all these *lake coppers*.

**OXIDE ORES** Surface deposits of copper ores tend to be oxides. These have been formed largely by the action of ground water, containing carbon dioxide, oxygen, and sulfuric acid, on primary sulfide minerals. Since the oxide ores were inclined to be somewhat richer, and were much easier to reduce to the metallic state than the sulfide ores, they largely have been exhausted, except in certain of the South American and African deposits.

**SULFIDE ORES** The ores of copper which are of greatest importance at the present time are complex mixtures of copper and iron sulfides, associated with compounds of antimony, arsenic, bismuth, gold, iron, platinum, selenium, silver, tellurium, and zinc in varying amounts.

#### COPPER-BEARING MINERALS

The most important copper-bearing minerals are listed in Table XIV.

TABLE XIV THE MOST IMPORTANT COPPER MINERALS

NAME	FORMULA	% COPPER WHEN PURE
<i>Chalcopyrite</i>	$\text{CuFeS}_2$	34.5
<i>Chalcocite</i>	$\text{Cu}_2\text{S}$	79.8
<i>Bornite</i>	$3\text{Cu}_2\text{S} \cdot \text{Fe}_2\text{S}_3$	55.5
<i>Tetrahedrite</i>	$\text{Cu}_3\text{SbS}_3 + x(\text{Fe}, \text{Zn})_6\text{Sb}_2\text{S}_9$	32–45
<i>Malachite</i>	$\text{CuCO}_3 \cdot \text{Cu}(\text{OH})_2$	57.3
<i>Azurite</i>	$2\text{CuCO}_3 \cdot \text{Cu}(\text{OH})_2$	55.1
<i>Cuprite</i>	$\text{Cu}_2\text{O}$	88.8
<i>Chrysocolla</i>	$\text{CuO} \cdot \text{SiO}_2 \cdot 2\text{H}_2\text{O}$	37.9

By using a combination of gravity concentration and froth flotation,

about 90% of the copper in the ore can be saved in the form of a concentrate containing about 30% copper.

EXTRACTION OF COPPER FROM ITS ORES

Copper is extracted most often from its ores by either pyro- or hydrometallurgical methods, and the choice between them is determined largely by the conditions obtaining in each individual case.

PYROMETALLURGICAL EXTRACTION

A typical simplified flow sheet for the pyrometallurgical extraction process is shown in Fig. 152.

**ROASTING** Oxidized ores may be treated directly, but sulfide ores first must be roasted. This consists of heating the ore to an elevated temperature with, at most, incipient fusion in order to effect a chemical change and to eliminate some components by volatilization. The components so removed may be water vapor (*drying*), carbon dioxide (*calcining*), or sulfur (*oxidizing*). Roasting also may result either in a change in form by partial oxidization to a sulfate (*sulfatizing*), to a chloride (*chloridizing*), or in a change in shape or agglomeration (*nodulizing*).

Roasting may be carried out in several ways:

1. *Heap roasting*, by making a pile of the ore and igniting it, a simple but inefficient method.
2. *Flat-hearth reverberatory furnace roasting*, either hand or mechanically raked.
3. *Kiln roasting* in revolving cylindrical furnaces slightly inclined so the charge enters at one end and proceeds slowly through the furnace, exiting at the other.

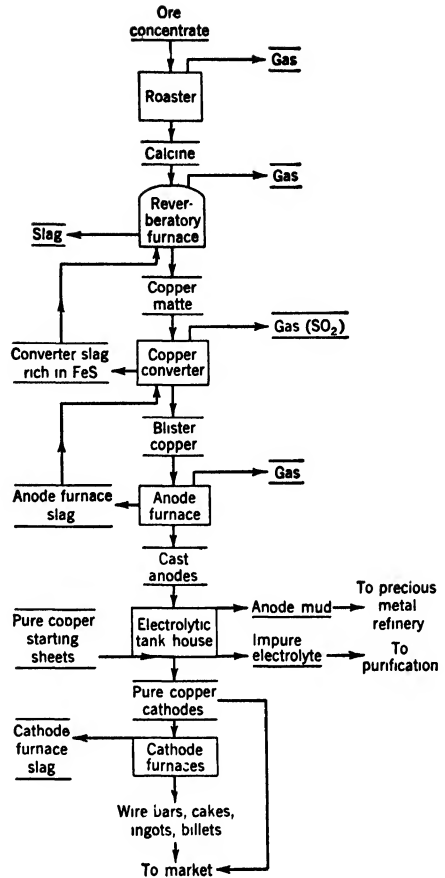


FIGURE 152. Simplified flow sheet of typical copper reduction and refining process.

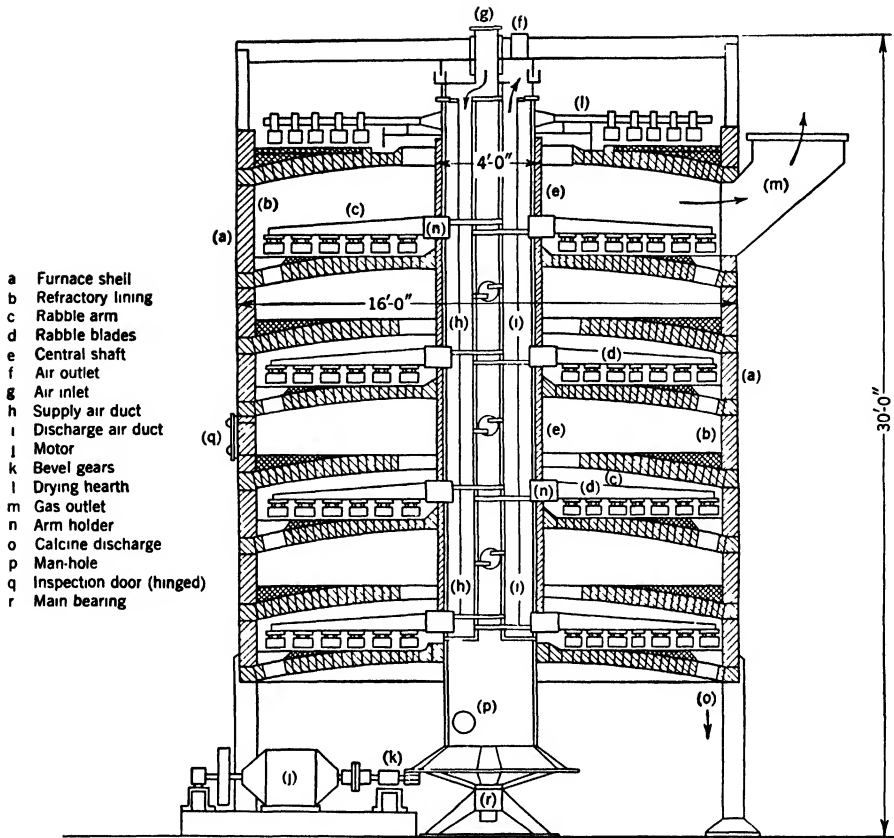


FIGURE 153. Cross section of typical multiple-hearth vertical roasting furnace of the Wedge type. (Reprinted by permission from *Non-Ferrous Production Metallurgy* by J. L. Bray, published by John Wiley & Sons, Inc., New York.)

4. *Multiple-hearth roasting* in vertical furnaces, of the general type illustrated in Fig. 153, in which the ore enters the top hearth and gradually increases in temperature as it passes down through and across each succeeding hearth. (The Wedge, MacDougall, and Nichols-Herreshoff furnaces are all modifications of this type.)
5. *Blast roasting*, by drawing air through a thin layer of ore on a moving grate, with sometimes the addition of oil to facilitate ignition. Blast roasting is used more frequently for roasting lead ores than for copper ores, so a description of the commonest means for doing it, the Dwight-Lloyd sintering machine, will be given later (Fig. 168) when lead is discussed.

**SMELTING OXIDE COPPER ORES** Oxide copper ores are reduced readily by carbon and carbon monoxide in a blast furnace. The gangue is fluxed off with some of the impurities although considerable antimony, arsenic,

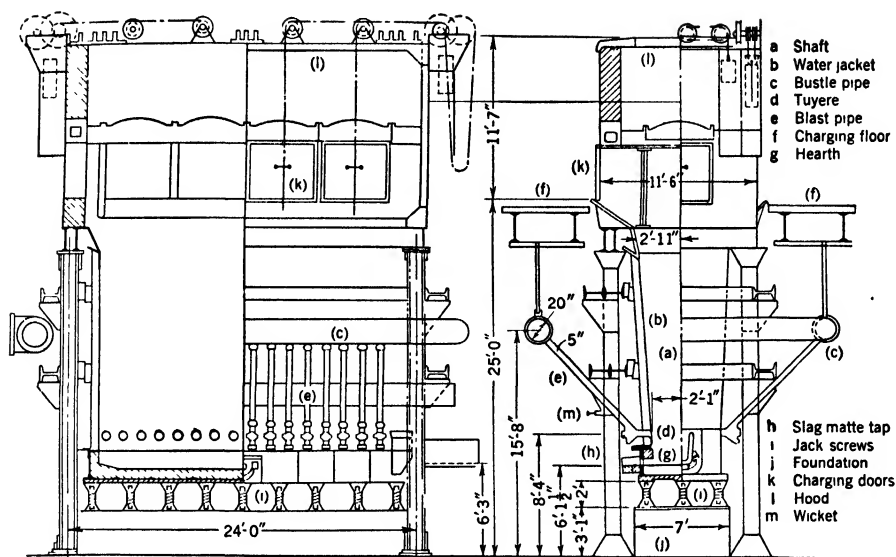


FIGURE 154. Copper blast furnace. (Courtesy Allis-Chalmers Manufacturing Company.) (Reprinted by permission from *Non-Ferrous Production Metallurgy* by J. L. Bray, published by John Wiley & Sons, Inc., New York.)

iron, sulfur, and precious metals will be retained in the metal, called *black copper*, containing 95–98% copper.

**SMELTING SULFIDE COPPER ORES** Sulfide copper ores contain both iron and copper sulfides, and it is essential that the two be separated. This can be done because:

1. Sulfur will combine preferentially with copper to form cuprous sulfide.
2. Oxygen will combine preferentially with iron to form ferrous oxide.
3. Liquid cuprous and ferrous sulfides are mutually soluble in each other, forming a *matte* which may contain 15–60% copper, and may range in specific gravity from 3.9 to 5.2.
4. The matte is heavier than the slag and will not dissolve in it.
5. The matte will dissolve all the precious metals as well as some of the other impurities such as antimony, arsenic, and bismuth.
6. Cuprous sulfide and oxide, when heated above 850 F (450 C), will react to form metallic copper and sulfur dioxide, according to the equation:



**BLAST-FURNACE SMELTING** Although the copper blast furnace, until recently, was being discarded slowly in favor of the reverberatory furnace, the results secured with some of the newly designed furnaces indicate that it may increase in importance again. A cross section of a typical copper blast furnace is shown in Fig. 154. The ore and sufficient car-

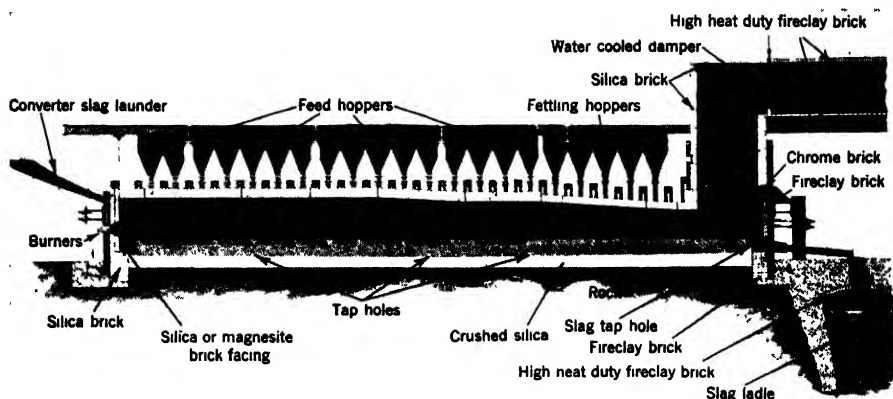


FIGURE 155. Typical reverberatory-type copper smelting furnace. (From *Modern Refractory Practice*, courtesy Harbison-Walker Refractories Company.)

bonaceous material are charged at the top, and from the furnace are obtained:

1. *Matte*, which contains 15–50% copper along with the precious metals and varying amounts of other impurities, and usually is treated in a converter to make blister copper.
2. *Slag*, which contains 0.25–0.50% copper, and generally is discarded, although ultimately it may prove to be a worth-while source of copper, especially when treated by hydrometallurgical methods.
3. *Flue dust*, viz., particles of ore, flux, and fuel, carried off by the furnace gases and collected by changing the velocity of the gases suddenly and then cooling them in large chambers, in bag houses, containing large woolen bags, or else by the use of Cottrell electrostatic precipitators.

**REVERBERATORY FURNACE SMELTING** The reverberatory smelting furnaces (Fig. 155) which have been superseding the blast furnace for copper, do nothing except melt down the ore and flux it rapidly with a minimum of heat loss.<sup>1</sup> A temperature high enough to permit the slag and matte to form and separate in a perfectly fluid condition can be maintained readily in them. As a rule these furnaces are 90–130 ft long and 18–20 ft wide, and have a hearth which will hold 1–4 ft of molten matte and slag. The usual operating temperature is about 2750 F (1500 C) at the firing end and 2100 F (1150 C) at the flue end.

The furnaces are charged with ore from above, and with molten converter slag through ports in the sides. The reactions taking place:

<sup>1</sup> See, for a further discussion, P. D. I. Honeyman, *Trans. A.I.M.E.*, 106, 1933, 88–96.

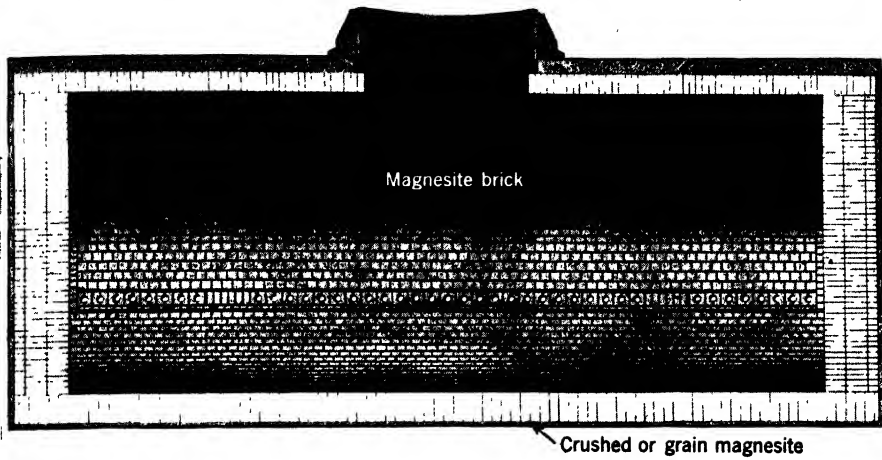
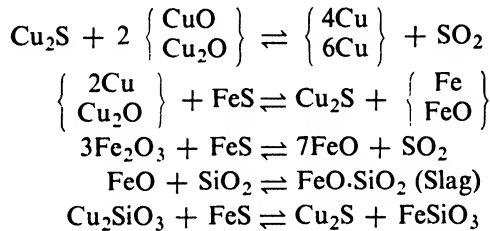


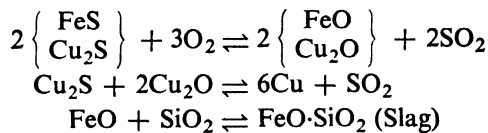
FIGURE 156. Horizontal or Peirce-Smith-type copper converter. (From *Modern Refractory Practice*, courtesy Harbison-Walker Refractories Company.)



lead to very little burning or elimination of sulfur. Instead, the copper, a part of the iron, and nearly all of the sulfur unite to form a matte. The remainder of the iron, as an oxide, forms a slag with the silica along with the other basic oxides in the ore. The matte also collects the precious metals as well as any antimony, arsenic, or bismuth.

The matte and slag separate quietly in the furnace. The slag overflows continuously from the flue end, and the matte is tapped at definite intervals from a side taphole.

**CONVERTING** Copper mattes are converted either in horizontal cylindrical converters of the *Peirce-Smith* type (Fig. 156) or in upright converters of the *Great Falls* type (Fig. 157).<sup>2</sup> The reactions involved:



<sup>2</sup> See also W. Kelly and F. Laist, *Trans. A.I.M.E.*, 106, 1933, 122-131.



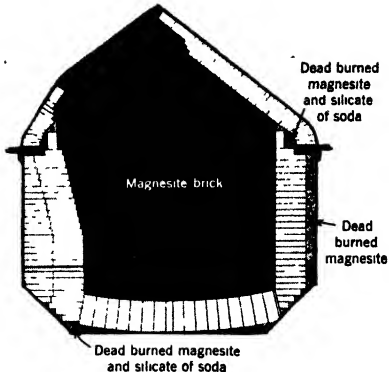


FIGURE 157. Upright or Great Falls-type copper converter. (From *Modern Refractory Practice*, courtesy Harbison-Walker Refractories Company.)

indicate how the chemical changes proceed. The heat given off by the slag reaction, along with the oxidation of the sulfur and iron, is sufficient to keep the bath molten. When all the sulfur associated with the iron has been oxidized in the first stage, the iron sulfide-rich slag is removed and only cuprous sulfide, known as *white metal*, is left. The blow then is continued in a second stage until some of the cuprous sulfide is oxidized, the cuprous oxide formed reacting with the cuprous sulfide remaining to form *blister copper* and sulfur dioxide. These

reactions continue until practically all the sulfur has been eliminated. The silver and gold remain in the blister copper along with some antimony, arsenic, and bismuth.

**FIRE REFINING OF BLISTER COPPER** Usually blister copper is fire-refined<sup>3</sup> whenever the precious metal content is too low to justify the more expensive electrolytic refining. Even when the metal is to be refined electrolytically, fire refining is carried out first to effect a partial purification and to minimize warping of the anodes during electrolysis.

Copper is fire-refined in a reverberatory furnace, which usually has a capacity of about 250 tons. The furnace first is charged with metal which is melted down in an oxidizing flame, forming large amounts of oxide. The charging and melting down stages take about  $10\frac{1}{2}$  hr. The molten metal will have over it a slag amounting to 1–4% of the charge and containing 15–30% copper.

During a period of about  $3\frac{1}{2}$  hr, the atmosphere is kept strongly oxidizing and air is bubbled through iron pipes immersed in the molten copper. This is continued until the bath reaches the desired state of purity (about 3.5%  $\text{Cu}_2\text{O}$ ) as determined by fracturing test buttons.

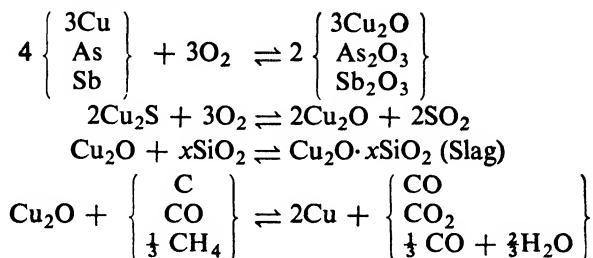
Hardwood poles, preferably green, then are inserted in the bath for about  $2\frac{1}{2}$  hr. Their decomposition in this stage of *poling* yields carbon and hydrocarbon gases, both of which agitate the bath and reduce the cuprous oxide content. Test buttons again are taken until the *tough-pitch* condition is reached, viz., 0.03–0.05% oxygen (0.27–0.45%  $\text{Cu}_2\text{O}$ ).

The tough-pitch stage was selected because ingots then have a flat set. Any further reduction of oxygen content would be impractical because

<sup>3</sup> See, for example, L. C. Fopeano, *Eng. and Min. Journ.*, 131, 1931, 515–517.

the impurities would be redissolved and the ingots would tend to become porous with a high set.

The melt then is ready for casting. The important reactions may be expressed quite simply:



If the precious-metal content is too low for recovery, the refined copper is cast directly into *wire bars, cakes, slabs, billets, ingots, or ingot bars* for industrial use (Fig. 158). However, if the precious-metal content is great enough to justify electrolytic refining, the fire-refining process is not carried to completion but just far enough to enable satisfactory anodes to be cast.

Lake copper generally is fire-refined, of course, because of its low precious-metal content. Two classifications are given in A.S.T.M. Standard B4, which covers it: (a) *low-resistance lake copper*, which must have a purity of at least 99.900% copper, silver, and arsenic, with a resistivity not to exceed 0.15328 international ohms per meter gram at 20 C (annealed) for wire bars and 0.15694 international ohms per meter gram at 20 C (annealed) for ingots and ingot bars; and (b) *high-resistance lake copper* which must have the same purity but with a resistivity greater than 0.15694 international ohms per meter gram at 20 C (annealed).

Fire-refined copper other than lake usually is intended for use for mechanical rather than electrical purposes, or in alloys. The following composition limits are specified for it in A.S.T.M. Standard B72:

% CU PLUS AG (MIN)		% AS (MAX)	% SB (MAX)	% BI (MAX)	% FE (MAX)
99.70	0.100	0.012	0.002	0.010	
% PB (MAX)	% NI (MAX)	% O <sub>2</sub> (MAX)	% SE (MAX)	% TE (MAX)	% SN (MAX)
0.010	0.100	0.075	0.040	0.014	0.050

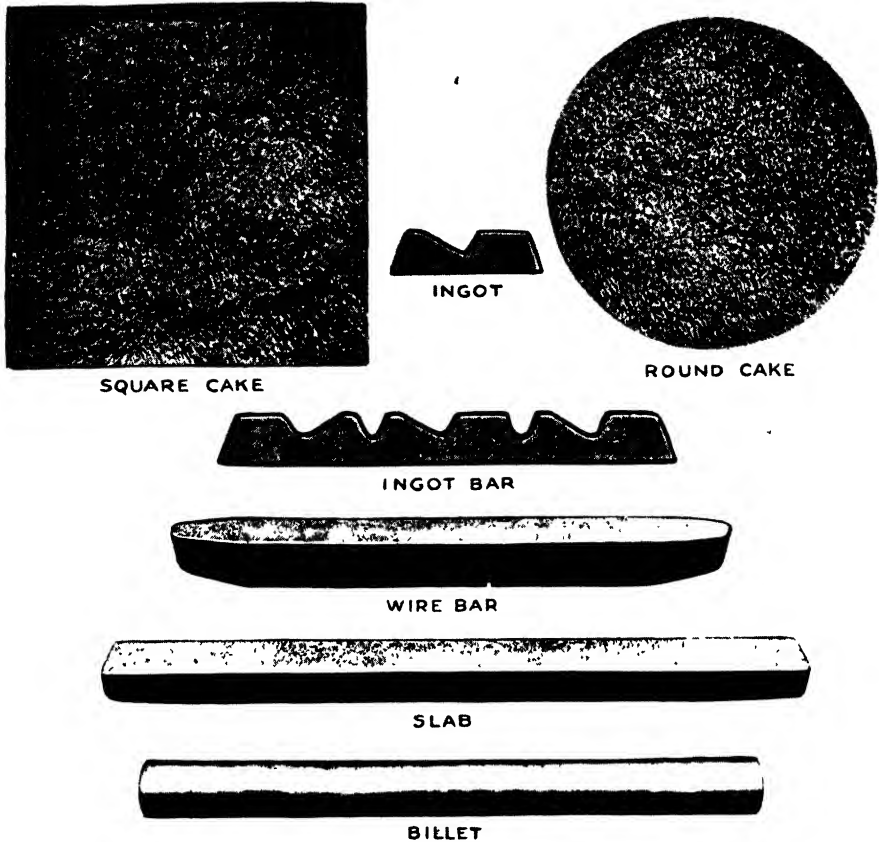


FIGURE 158. Commercial refinery shapes into which copper is cast for industrial use. (Courtesy International Smelting and Refining Company and the Anaconda Copper Mining Company.)

**ELECTROLYTIC REFINING** Using cast anodes of partially refined copper weighing 400–700 lb (Fig. 159), pure copper starting sheets about  $\frac{1}{16}$  in. thick and weighing about 7 lb, and an electrolyte containing about 3–4% copper and 10–16% free sulfuric acid, copper readily can be deposited electrolytically in a very pure form. Two common electrical hookups are used:

1. In the simple *multiple* system<sup>4</sup> (Fig. 160), individual tanks are connected in series although the electrodes in each tank are in parallel. Each tank contains thirty anodes and thirty-one cathodes. About 1 month is required to corrode an anode, during which time two or three cathodes are removed. The Walker method of connecting (Fig. 161a) is most com-

<sup>4</sup> See also F. Benard, *Trans. A.I.M.E.*, 106, 1933, 369–397.

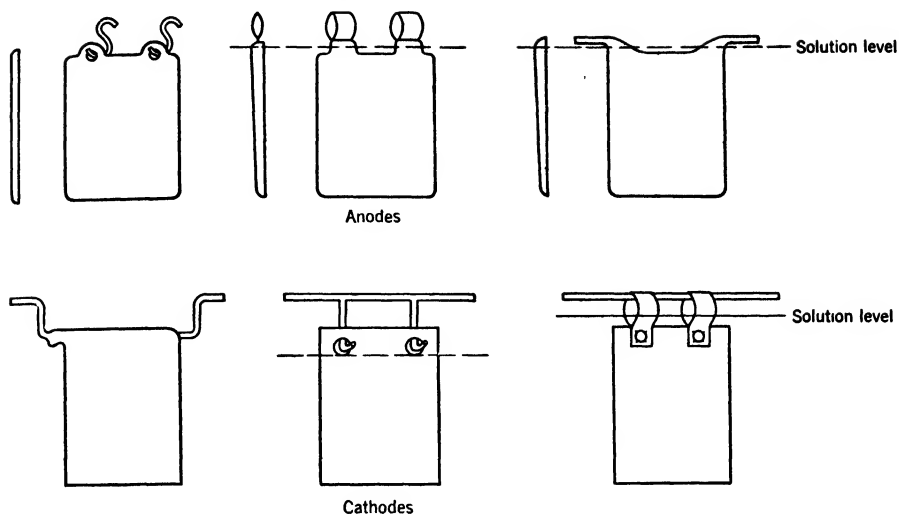


FIGURE 159. Electrode shapes. (Reprinted by permission from *Non-Ferrous Production Metallurgy* by J. L. Bray, published by John Wiley & Sons, Inc., New York.)

mon, with fifteen to eighteen tanks in series, although both the Whitehead and Aubel methods (Figs. 161*b*, 161*c*) are used to some extent. Using a current density of 20–25 amp per sq ft, about 0.2–0.4 v per tank would be required with 7000–10,000 amp and a current efficiency of 89–96%. The temperature of the electrolyte is kept between about 100 and 140 F (40–60 C). The electrolyte is circulated continually at a rate of 3–6 gal per min.

2. In the *series* system<sup>5</sup> (Fig. 162), cast or rolled electrodes are placed vertically in a tank, with one end electrode positive and the other end electrode negative. Successive tanks usually are connected in parallel. Under these conditions copper goes into solution from the front or anode surface of an electrode, and is plated out on the back or cathode surface of the next electrode. The electrodes, therefore, are *bipolar*, i.e., each face is at a different polarity with reference to its opposing electrode. For practical reasons electrolysis never is continued until all of the anode surface is dissolved, but the remainder of the impure anode can be stripped readily from the pure cathode deposit. Under this system a much smaller potential drop between electrodes occurs (0.15–0.30 v); much less scrap is secured; and much less metal is tied up in bus bars, etc. Less than half the floor space of the multiple system also is required for a given output using the series system, although the individual tanks are much deeper. About 17 v and 76 amp are required per tank with a current density of 12–27 amp per sq ft of cathode surface. The current efficiency is only 70–89%, however.

<sup>5</sup> See also C. S. Harloff and H. F. Johnson, *Trans. A.I.M.E.*, 106, 1933, 398–407.

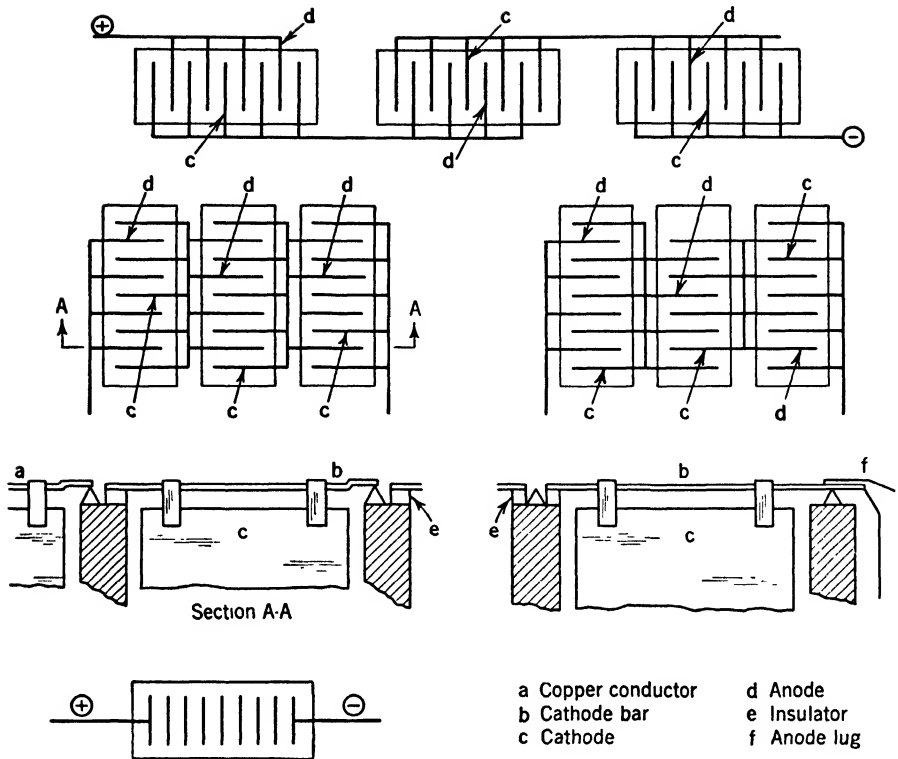


FIGURE 160. (Row 1) Diagrammatic representation of the simple multiple system of connections used in the electrolytic refining of copper. (Reprinted by permission from *Non-Ferrous Production Metallurgy* by J. L. Bray, published by John Wiley & Sons, Inc., New York.)

FIGURE 161. (Rows 2 and 3) Diagrammatic representation of the common multiple systems of connections used in the electrolytic refining of copper. a. (Left) Walker multiple connection. b. (Upper right) Whitehead multiple connection. c. (Lower right) Aibel multiple connection. (Reprinted by permission from *Non-Ferrous Production Metallurgy* by J. L. Bray, published by John Wiley & Sons, Inc., New York.)

FIGURE 162. (Row 4) Diagrammatic representation of the series system of connections used in the electrolytic refining of copper. (Reprinted by permission from *Non-Ferrous Production Metallurgy* by J. L. Bray, published by John Wiley & Sons, Inc., New York.)

Most refineries in this country operate on the multiple system, largely because labor costs for stripping are so high in series refining. This condition will exist as long as the anode scrap must be chipped off laboriously by hand with cold chisels. It is significant that the new tank houses all are multiple connected even though the series system may have been used previously.

Cathodes either are cut up into smaller sizes or else remelted in the fire-refining reverberatory furnaces for casting into commercial shapes.

It is required by A.S.T.M. Standard B115 that electrolytic cathodes have a minimum purity of 99.90% copper, silver being counted as copper; and that the resistivity shall not exceed 0.15328 international ohms per meter gram at 20 C (annealed).

Cathodes, remelted into wire bars, cakes, slabs, billets, ingots, and ingot bars in the same manner as in fire refining, are sold as electrolytic copper and fall within the limits of A.S.T.M. Standard B5. This specifies a purity of at least 99.900% copper, silver being counted as copper, and a resistivity not to exceed 0.15328 international ohms per meter gram at 20 C (annealed) for wire bars, or 0.15694 international ohms per meter gram at 20 C (annealed) for ingots or ingot bars or nonelectrical uses.

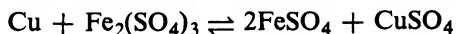
#### ANODE SLIMES

The insoluble slimes which settle at the anodes contain the precious metals as well as any selenium and tellurium. They are treated<sup>6</sup> to secure a gold-silver *bullion* which then is refined electrolytically by different processes to remove the gold, silver, palladium, and platinum.

#### HYDROMETALLURGY OF COPPER

Once the copper ores have been roasted to a soluble form, they can be leached with sulfuric acid, sulfur dioxide, ferric chloride, cupric chloride, hydrochloric acid, chlorine, nitric acid, or any other convenient solvent.<sup>7</sup> Ferric sulfate commonly is used for leaching unroasted sulfides, and ammonia or ammonium compounds for leaching native copper. The copper in solution then may be removed either electrolytically or by cementation on scrap iron.

The electrolytic methods are probably most common, using a multiple system with insoluble anodes and about ten times as much current as in the multiple system of refining.<sup>8</sup> The solution is more difficult to control than that used in electrolytic refining, iron in particular being a damaging impurity because it tends to redissolve copper according to the equation:



thus lowering the efficiency, not only because of the re-solution, but also because of the energy expended in reducing the iron dissolved as sulfate from the ferric to the ferrous state.

Generally, cementation on scrap iron is used only as a treatment for

<sup>6</sup> For a more complete discussion see M. A. Mosher, *Trans. A.I.M.E.*, **106**, 1933, 427-440.

<sup>7</sup> See, for example, J. D. Sullivan, *Trans. A.I.M.E.*, **106**, 1933, 515-546.

<sup>8</sup> See, for example, T. C. Campbell, *Trans. A.I.M.E.*, **106**, 1933, 559-608.

liquors that are about to be discarded, since the iron content of the solution would be built up by this method.

This is the only important source of selenium, tellurium and the platinum metals in the United States and a large source of silver and gold.

#### ARSENICAL COPPER

Copper ores which run high in arsenic may be so treated, in their reduction and refining, that 0.15–0.75% arsenic is left in the copper, even after the fire refining is completed. These coppers then would be marketed as arsenical coppers, and would be used for certain specific applications because of their somewhat greater corrosion resistance as will be discussed later. The exact chemical composition will be determined by the specific application, as indicated for high-resistance lake copper in A.S.T.M. Standard B4.

#### OXYGEN-FREE COPPER

The commercial high-conductivity coppers, viz., O.F.H.C. (oxygen-free high-conductivity) copper<sup>9</sup> and its competitive brands, are made by further deoxidizing the tough-pitch copper either in the furnace or in the ladle with barium, calcium, carbon, lithium, or very carefully controlled amounts of phosphorus (in the form of a phosphor-copper master alloy). With the first four of these very little difficulty is encountered, because the carbon has no tendency either to dissolve in or to form compounds with molten copper, and the other three both oxidize and volatilize readily at this temperature. However, the fifth is more troublesome because some phosphorus will remain unless the minimum amount necessary is added. Hence this deoxidizer is much more difficult to use properly if high conductivity copper is desired. Excess phosphorus will lower the conductivity markedly and therefore must be avoided. However, by proper treatment practically no residual oxide or deoxidizer remains. In addition to the careful deoxidation, vertical water-cooled molds are used for casting these oxygen-free coppers, thus giving a more uniform and more homogeneous ingot than ordinarily is secured. The net result is a very clean, high-purity copper having a very high electrical conductivity. The freedom from inclusions of this structure in comparison with the usual oxygen-bearing copper can be seen clearly by comparing the photomicrographs shown in Figs. 163*a* and *c*. The structures of phosphorus deoxidized (low-conductivity), O.F.H.C.

<sup>9</sup> See, for example, E. F. Cone, *Metals and Alloys*, 8, 1937, 33–37.

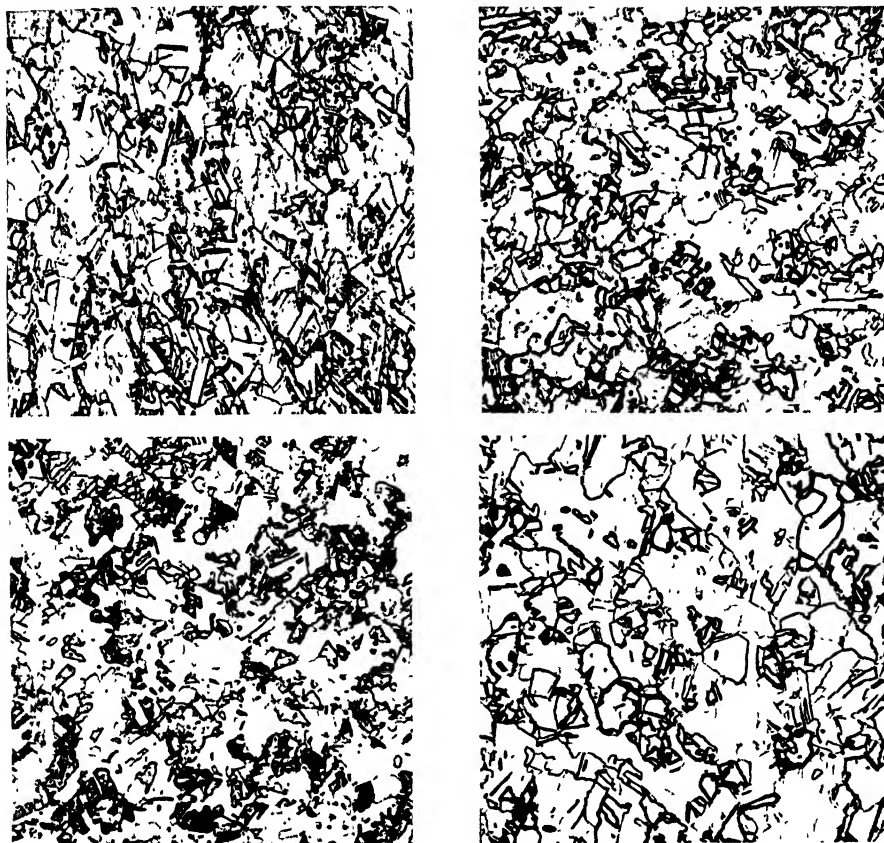


FIGURE 163. Metallographic structures typical of various types of commercial copper. Etched with  $\text{NH}_4\text{OH} + \text{H}_2\text{O}_2$ .  $\times 125$ . *a.* (Upper left) Oxygen-bearing tough-pitch electrolytic copper. *b.* (Upper right) Regular phosphorus deoxidized copper. *c.* (Lower left) O.F.H.C. copper. *d.* (Lower right) High-purity copper. (Photomicrographs courtesy Research Laboratory, American Smelting and Refining Company.)

copper, and high-purity copper are quite similar as shown by Fig. 163*b*, *c*, and *d*.

## *Nickel*

### NICKEL ORES

Although there are numerous deposits of nickel-bearing minerals in the world, only three are sizable ore bodies and only two of these have been developed to any extent:

1. The deposits at Sudbury, Ontario, were developed in 1886 and at pres-



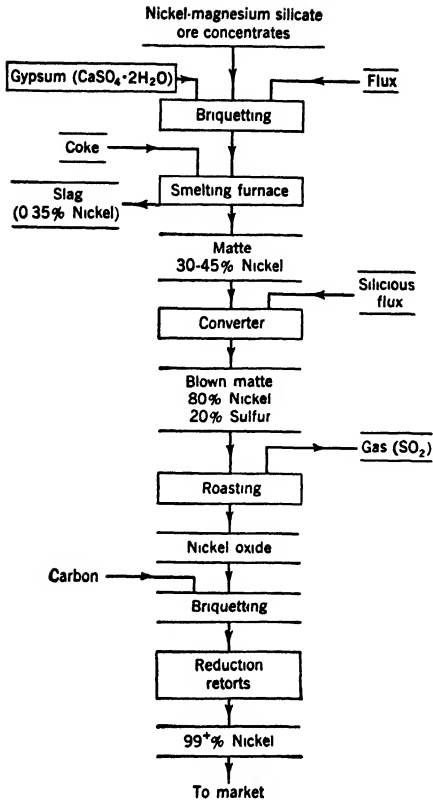


FIGURE 164. Simplified flow sheet of process used for extracting nickel from silicate ores.

ent furnish better than 90% of the world's output. The ore consists of a nickel-copper sulfide intimately mixed with *pyrrhotite* ( $\text{Fe}_8\text{S}_9$ ), *chalcopyrite* ( $\text{CuFeS}_2$ ), *pentlandite* ( $\text{Fe,Ni}_{11}\text{S}_{10}$ ), and considerable rocky gangue. These ores will vary from an actual content of less than 2% to more than 4% nickel, and from less than 1% to about 4% copper. Hence, most of the ores must be concentrated before smelting. These ores also contain appreciable amounts of gold, silver, and metals of the platinum group, extremely valuable by-products.

2. The deposits in New Caledonia in the South Pacific have been worked since 1875, and supply about 7% of the present world's output, although they were the only source before the discovery of the Sudbury deposits. These ores consist chiefly of

*noumcite*, or *garnierite*, a complex hydrated nickel-magnesium silicate. It is noteworthy that they contain neither copper nor sulfur, and that, in addition, no precious metals are recovered from them. In the early days these ores contained as much as 10–12% nickel, but the present output contains only about half of this amount.

Additional deposits in Petsamo, Finland, are being developed but their future is, at present, in doubt. The ores are similar in character to the Canadian deposits, but are of a lower grade. The deposits are, however, much smaller than the other two mentioned.

#### TREATMENT OF SILICATE ORES

The silicate ores are treated, as indicated by the simplified flow sheet in Fig. 164, by briquetting with a sulfur-bearing material, usually gypsum

( $\text{CaSO}_4 \cdot 2\text{H}_2\text{O}$ ), and with fluxes for taking care of the silicious gangue. By smelting with coke, a matte containing 30–45% nickel is produced as well as a slag which can be discarded completely because of its low nickel content (0.35%).

The matte then is blown in a converter with a silicious flux to oxidize some of the sulfur and to remove some of the iron. The product, containing about 80% Ni–20% S and a small amount of iron, first is ground, and then roasted until it is free of sulfur and consists almost entirely of pure nickel oxide. This oxide is briquetted with a carbonaceous material, and reduced to metallic nickel (99.25% nickel) by heating to bright redness for 48 hr in horizontal retorts.

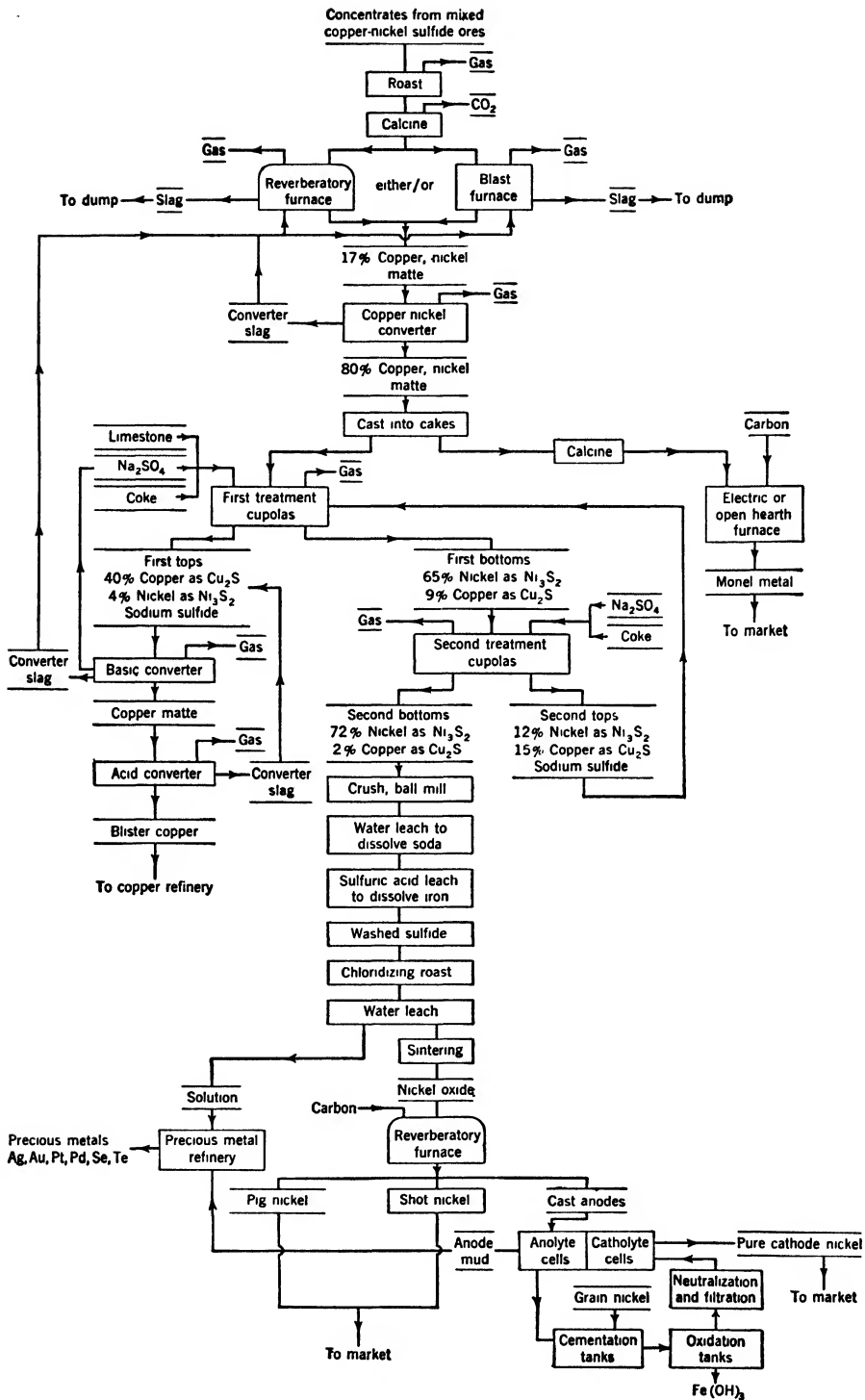
#### TREATMENT OF SULFIDE ORES

The treatment of sulfide ores consists of several steps as illustrated in the simplified flow sheet given in Fig. 165.

**PRODUCTION OF MATTE** The crude concentrates contain about 1.5% copper, 4.5% nickel, and 45% iron, the remainder being essentially sulfur, silica, alumina, lime, and magnesia. These are roasted in multiple-hearth furnaces to reduce the sulfur from about 25% to about 10%. The calcines then are charged into reverberatory furnaces or blast furnaces along with some raw ore, flue dust, and liquid slag or other appropriate fluxes. The reverberatory furnaces can smelt about 1000 tons of charge in 24 hr to a matte containing about 17% copper plus nickel, 51% iron, and 27% sulfur. In addition, a slag is formed containing about 0.5% copper plus nickel, 42.5% iron, along with about 2% sulfur, 32% silica, 6% alumina, 3% lime, 5% magnesia.

**CONVERTING** The matte from the reverberatory furnaces is charged into 100-ton capacity, basic-lined, horizontal Peirce-Smith converters, and blown down with a silicious flux which aids in slagging off the iron. After 50 or 60 hr blowing, a high-grade matte containing about 80% copper plus nickel  $\left\{ \begin{array}{l} \text{Ni} = 54 \\ \text{Cu} = 26 \end{array} \right\}$ , 20% sulfur, and 0.3% iron is produced. This is cast into slabs and then broken into small pieces and treated to separate the nickel and copper. If *Monel metal* (approximately 70% Ni–30% Cu) is to be made, this matte is calcined and then reduced by carbon directly to the alloy in electric or open-hearth furnaces.

**THE TOPS-AND-BOTTOMS PROCESS** The *Orford* or tops-and-bottoms process, which is used to separate the copper and nickel if metallic nickel is to be made, depends on the fact that, in the molten system: nickel sulfide–copper sulfide–sodium sulfide, two liquid layers tend to separate. In the



upper layer will be found most of the sodium and copper sulfides, in the lower nickel sulfide.

To accomplish this separation, two treatments usually are given. In the first treatment the converter matte is smelted in cupolas or blast furnaces with sodium sulfate (salt cake), coke, any tops from the second treatment, and various smelter by-products. The molten sulfide runs into large pots and cools over a period of about 36 hr during which separation of the constituents takes place. From this separation is secured the *first tops*, containing about 40% copper and 4% nickel as sulfides, the remainder chiefly sodium sulfide; and the *first bottoms*, containing about 9% copper and 65% nickel, the remainder chiefly sulfur.

The first bottoms then are smelted further with sodium sulfate and coke yielding a *second tops* containing about 15% copper and 12% nickel and a *second bottoms* containing about 2% copper and 72% nickel.

The first tops go to *basic-lined* converters, where the sodium sulfide is oxidized to sulfate and reclaimed for further use. The copper sulfide, containing a little nickel, is treated as a copper matte and refined to blister copper in *acid-lined* furnaces.

**LEACHING OF SECOND BOTTOMS** The second bottoms, rich in nickel, are ground and mixed with water in large lead-lined concrete leaching tanks, into the bottom of which a filter is built. Water is percolated through this mass and after about 2 days nearly all the sodium sulfide has been washed out. Most of the iron, as well as considerable nickel, unfortunately, next is dissolved selectively in hot dilute sulfuric acid; and this solution later is treated further to remove the nickel.

The material left, known as *washed sulfide*, contains about 75% nickel, 0.15% iron, and 1.5% copper, with the remainder sulfur. This then is roasted, reducing the sulfur from about 25% to about 4%. It next is mixed with about 15% coarse salt, and roasted again (chloridized) for about 24 hr in a special furnace in which the mass is cooled slowly as it moves toward the discharge end. At this stage the copper has been converted completely to cuprous chloride which then can be removed by leaching with hot water and weak leaching liquor. Some of the nickel also is dissolved here but it is recovered later.

#### PRODUCTION OF ELECTROLYTIC NICKEL

The nickel sulfide, from which most of the copper has been removed, is desulfurized next to about 0.4% sulfur by sintering, and reduced to metal

---

FIGURE 165. Simplified flow sheet illustrating the production of Monel metal, the extraction of nickel from sulfide ores by the Orford process, and the purification of nickel by the Hybinette electrolytic method.

by carbon in a reverberatory furnace. This metal is cast into anodes weighing about 425 lb and electrolyzed in a manner similar to that already described for copper, using 11-lb starting sheets of pure nickel. It also may be cast into pigs or shotted for direct sale as metallic nickel if desired.

In the electrolysis of nickel, however, as shown schematically in Fig. 165, certain precautions must be taken that are not required for copper. In particular, *the cathodic and anodic solutions must be kept separate*. This is accomplished by using a heavy canvas "box" around the cathode which thus is immersed always in pure electrolyte.

Impure solution is taken continuously from the anode compartment, heated to 175 F (80 C), and passed through a series of tanks containing finely divided nickel upon which the copper is deposited by cementation. The liquid then is oxidized to remove any iron as hydroxide, neutralized by nickel carbonate, filtered, and pumped to the cathode chamber.

The separation between the two solutions depends entirely on the fact that the electrolyte flows from the cathode cells through the diaphragms into the anode cells at a rate greater than the velocity of the ions, and thus the impurities dissolved from the anodes cannot reach the cathodes. Nickel ions formed at the anode must travel, therefore, through the entire purification cycle in order to reach the cathodes and be discharged.

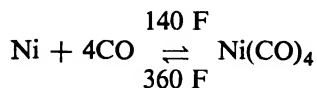
The efficiency of the electrolysis is about 94%, with a current density of about 12 amp per sq ft, and a potential drop between electrodes of 2.4 v.

The nickel cathodes produced either may be sheared to smaller sizes for shipment or else remelted for marketing as ingots or shot.

The anode slimes contain relatively large amounts of gold, platinum, selenium, silver, and tellurium, and are treated by both chemical and electrolytic methods to recover these elements in a manner similar to that used for copper anode slimes.

#### THE MOND PROCESS

Although it no longer is used commercially, the principle upon which the Mond process is based is extremely interesting. A simplified flow sheet of the process is shown in Fig. 166. If nickel oxide is treated with water gas, essentially a mixture of hydrogen and carbon monoxide, at 650–750 F (350–400 C) the nickel will be reduced to the metallic state. If this nickel is cooled then and exposed to the action of carbon monoxide at about 140 F (60 C), a gaseous nickel carbonyl will form according to the equation:



This gaseous carbonyl then is heated to 360 F (180 C) in vertical columns filled with pure nickel shot. Under these conditions the carbonyl gas decomposes, depositing metallic nickel on the surface of the shot. Very careful control is required for efficient operation. By an automatic sizing process, the nickel shot is collected as soon as it reaches a certain diameter, and then may be remelted for commercial sale.

Nickel produced by this method will contain less than 0.06% iron and 0.09% copper as impurities. The process is, however, so slow and, relatively, so expensive in comparison with the Orford process, that it is no longer in commercial use.

#### COMMERCIAL NICKEL

Four grades of virgin nickel, i.e., nickel made from ore, matte, or similar raw material by refining processes and not produced from remelted metal, are covered by A.S.T.M. Standard B39:

1. *Electrolytic*, suitable for the manufacture of the highest grades of malleable nickel alloys.
2. *X shot*, suitable for the manufacture of nonferrous alloys and nickel steel.
3. *A shot*, suitable for the manufacture of anodes.
4. *Ingot*, suitable for the manufacture of open-hearth and electric-furnace nickel steel.

These various grades must conform to the chemical requirements shown in Table XV.

TABLE XV A.S.T.M. CHEMICAL REQUIREMENTS FOR VARIOUS GRADES OF NICKEL

GRADE	% NI AND CO (MIN)	% S (MAX)	% C (MAX)	% FE (MAX)
Electrolytic	99.50	0.02	0.10	0.25
X shot	98.90	0.05	0.25	0.60
A shot	97.75	0.07	0.75	0.90
Ingot	98.50	—	—	—

### *Lead*

#### LEAD ORES

The most common ores of lead are either sulfides or oxides, and generally they will contain iron, zinc, and sometimes copper as impurities. The

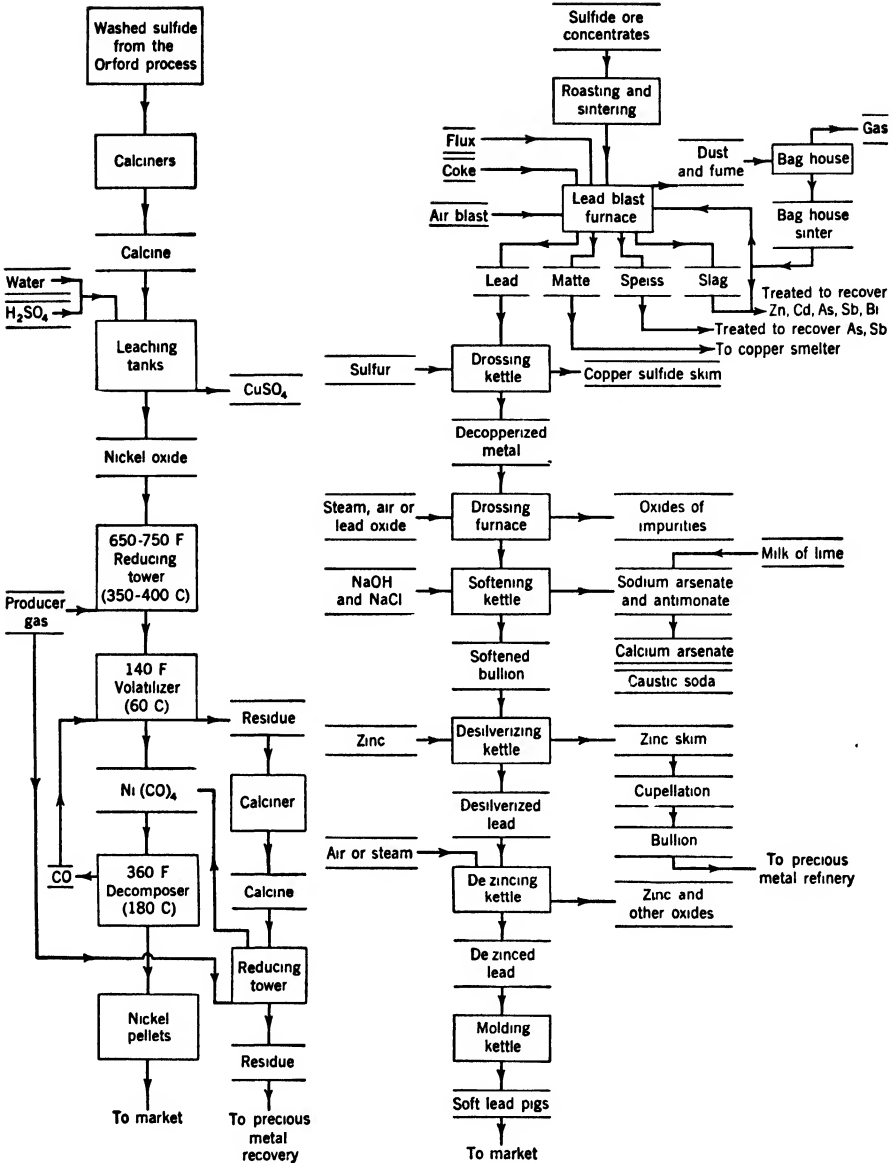


FIGURE 166. (Left) Simplified flow sheet illustrating the Mond process for the production of pure nickel from Orford process "washed sulfide."

FIGURE 167. (Right) Simplified flow sheet illustrating the extraction of lead from sulfide ores and subsequent refining to soft lead.

average lead content of United States ores is about 5% although ores containing as low as 3% are being worked successfully.

Many of the ores are flotation concentrated to better than 70% lead

before treatment. However, a fair quantity of Mississippi basin ore is hand picked but not otherwise concentrated. This is done largely to obtain a separation of lead and zinc which cannot be smelted well together and which occur together in the most abundant ores. Ordinarily, lead ores also contain sizable amounts of silver, which increases their value appreciably.

Next to the United States, which produced about 22% of the world's lead supply before 1940, the largest producers are Australia, Canada, Germany, Mexico, Burma, and U.S.S.R. Missouri, Idaho, and Utah supply the majority of the lead ores in this country.

The three principal ores of lead in use today consist largely of:

1. *Galena* ( $\text{PbS}$ , containing 86.6% lead when pure), the commonest ore, frequently occurring pure, especially in the Mississippi Valley deposits.
2. *Anglesite* ( $\text{PbSO}_4$ , containing 68.3% lead when pure).
3. *Cerrussite* ( $\text{PbCO}_3$ , containing 77.5% lead when pure), the commonest oxidized ore.

Because of the low purity in which they are found in ore deposits, the latter two ores usually are mixed with roasted sulfide ores before being reduced.

#### TREATMENT OF SULFIDE ORES

At the usual operating temperatures, lead sulfide is not reduced readily by either carbon or carbon monoxide. Hence, it must be roasted before smelting. In lead smelting both metal and matte are produced. Therefore the percentage of sulfur must be controlled by roasting or sintering, not only to minimize the amount of lead that occurs as matte, from which metal can be recovered only with difficulty, but also to limit the heat generated in the smelting process by the oxidation of sulfur. Too much heat causes the remaining lead sulfide to fuse into matte during the sintering process itself. A simplified flow sheet of the extraction process is given in Fig. 167.

**ROASTING OR SINTERING** Galena is friable, brittle, and fuses easily, but to be treated most efficiently it must be gotten into a form where it is hard, strong, and yet porous, i.e., into the form of a *sinter* or *clinker*. Material of this sort is produced best on a sintering machine of the *Dwight-Lloyd* type illustrated in Fig. 168. This machine utilizes a continuous down-draft method of blast roasting. The oxidation is effected by internal combustion, and is propagated within the mass of ore particles by air currents forced down through it. It is a continuous roaster treating a charge 4–7 in. thick which contains some water so the mass can be handled more easily. The thickness of the bed determines the speed of travel, the thicker beds requiring slower speeds for equal results.



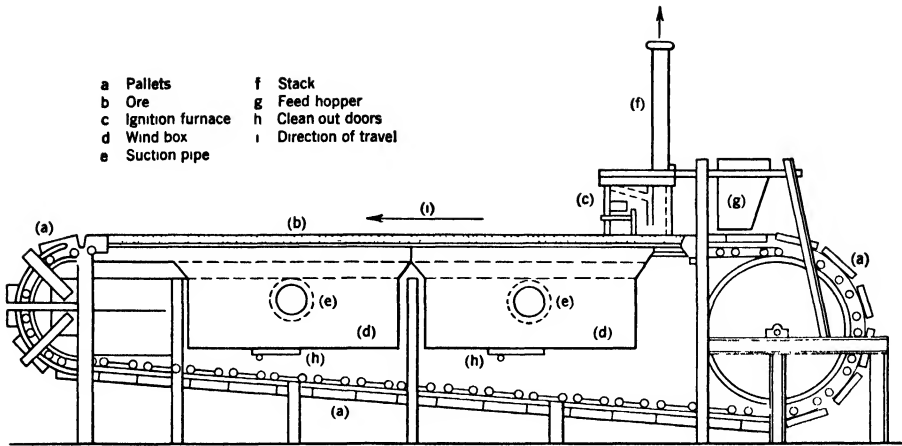
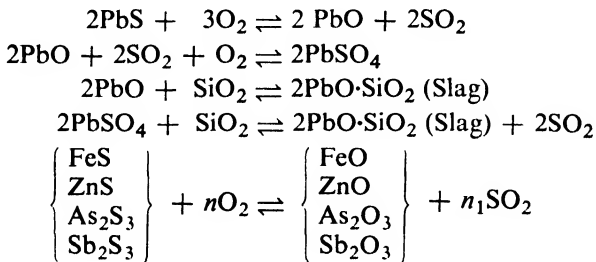


FIGURE 168. Diagrammatic cross section of a Dwight-Lloyd-type sintering machine. (Reprinted by permission from *Non-Ferrous Production Metallurgy* by J. L. Bray, published by John Wiley & Sons, Inc., New York.)

Two Dwight-Lloyds frequently are used in series. In the first, only part of the initial 8–9% sulfur is removed, and the sinter then is crushed and roasted again to remove the remainder. In the product of the final sinter there usually will be left only about 1–2% sulfur.

In the sintering process the mass may reach temperatures of the order of 1475 F (800 C). At these temperatures the silicates become sticky, thus assisting markedly in the process of agglomeration. The final sinter will contain about 52% lead, 2% sulfur, 8% silica, 15% FeO, 3% lime, and small amounts of other metals and oxides.

Any of the following reactions may occur in roasting:



By careful control of the temperature, the amount of lead sulfate can be kept to a minimum, and this must be done for best results.

If its charge is sintered properly, the lead blast furnace becomes little more than a melting device, since the reduction of lead oxide to metallic lead by carbon monoxide or carbon takes place rapidly. The capacity of

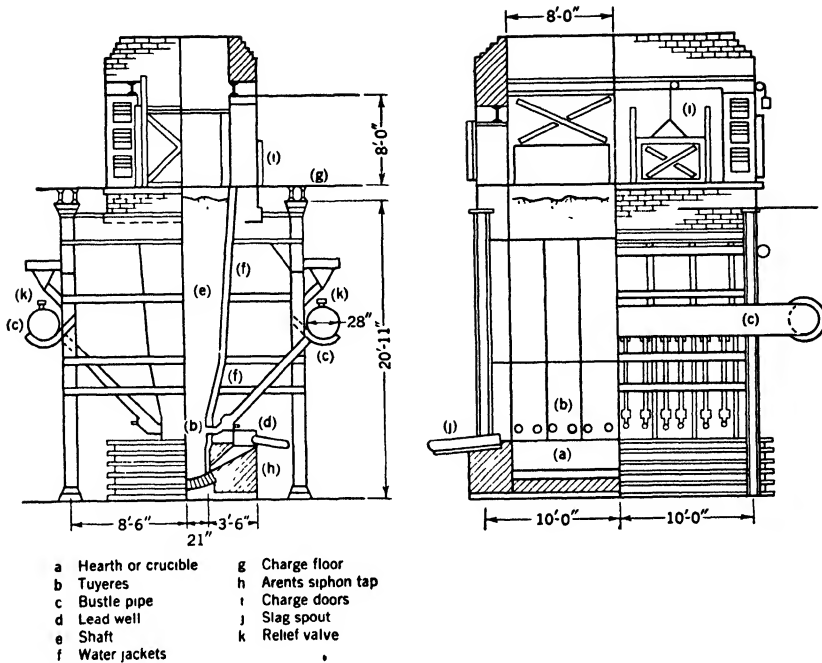


FIGURE 169. Lead blast furnace. (Reprinted by permission from *Non-Ferrous Production Metallurgy* by J. L. Bray, published by John Wiley & Sons, Inc., New York.)

the blast furnace is increased greatly thereby, sometimes as much as sixfold over what it would be were it not for the preliminary sintering.

**BLAST-FURNACE SMELTING** Sulfide ores containing more than 5% silica and all impure ores must be treated in the lead blast furnace.<sup>10</sup>

The lead blast furnace (Fig. 169) is similar in construction to the copper blast furnace although, since the principal product is metal rather than matte, it is operated somewhat differently.

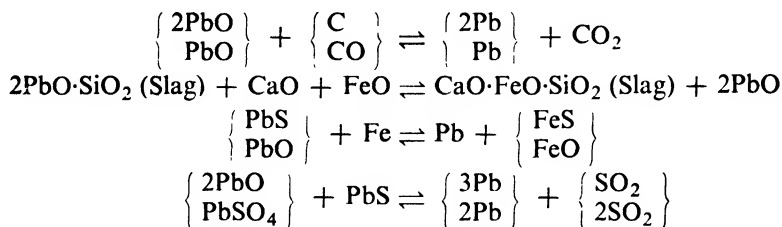
In the lead blast furnace the crucible, which will hold 20–40 tons of metal, must be about 30 in. deep, and metal is syphoned from it to a *lead well* outside the furnace.

The charge contains 16–50% lead and consists of properly proportioned mixtures of ore, flux, and coke. Even distribution of it is required because of the inherent conditions of operation of a blast furnace.

Practically, lead blast-furnace slags must be heated above 1850 F (1000 C) in order to melt them. At this temperature, which is reached in the tuyere zone, the coke, comprising about 14% of the charge, burns almost entirely to carbon monoxide. However, there will be zones in the

<sup>10</sup> See, for a complete discussion, *Metallurgy of Lead and Zinc*, *Trans. A.I.M.E.*, **121**, 1936, 45–105.

furnace, because of its construction, where considerable carbon dioxide is present. Any of the oxidized lead compounds can be reduced to metal at these temperatures. Typical reactions are:



*Slag*, containing about 1.5% lead, is tapped intermittently, together with some *matte*, containing about 15% lead, and *speiss*, which consists principally of the arsenides and antimonides of copper and iron. Separation between the three takes place in a settler. The slag overflows, and usually is granulated and treated, with the flue dust, to recover any zinc, cadmium, arsenic, antimony, and bismuth. The *matte* goes to the copper smelter for recovery of its copper, which may run 10% or higher, and precious-metal content; the *speiss*, if any, usually is sold for arsenic and antimony recovery at a plant having suitable kitchens.

#### SOFTENING OF LEAD BULLION

The lead bullion generally must be softened<sup>11</sup> and desilverized before it is pure enough to be used industrially, although bullion obtained from Mississippi Valley ores is *soft* enough, i.e., pure enough, for most commercial uses without further refining.

Nearly all leads must be given some refining treatment in order to remove small amounts of antimony, arsenic, bismuth, copper, gold, silver, tin, and zinc, impurities which invariably are present. A simplified flow sheet of a typical refining process also is shown in Fig. 167.

**DROSSING** Drossing is a process of oxidation and liquation, carried out in a reverberatory furnace, similar to that shown in Fig. 170, in which the lead is held in a molten state long enough to allow insoluble or oxidized material to rise to the surface and be skimmed off. This frequently is assisted by agitation either mechanically or with air or steam. Sulfur often is stirred into the drossing kettle to remove copper as the sulfide.

**SOFTENING** In order to remove the impurities that tend to interfere with desilverization, the lead is put through a softening process in a shallow-hearth reverberatory furnace, holding sometimes as much as 350 tons

<sup>11</sup> This is discussed in detail by A. E. Hall, *Trans. A.I.M.E.*, 121, 1936, 194-204.

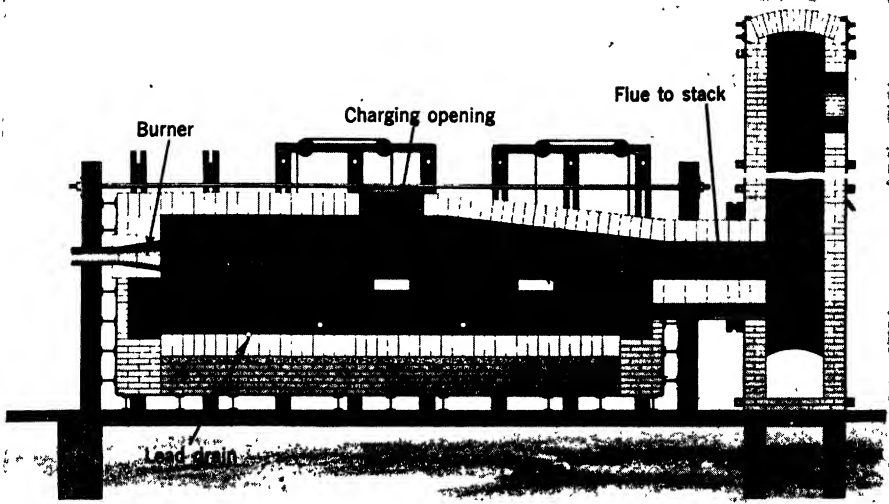
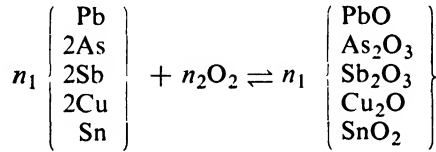


FIGURE 170. Typical lead dressing furnace. (From *Modern Refractory Practice*, courtesy Harbison-Walker Refractories Company.)

of metal. The reactions involved are all simple oxidations as indicated below:



Usually this is done in two stages: (a) *copper dressing*, and (b) *antimony dressing*.

First, the bullion is held at a temperature just above its melting point, about 700 F (375 C), for about 2 hr. During this time a dross consisting chiefly of arsenic, copper, lead, and sulfur will rise to the surface. This *copper skim* is removed and retreated. After this treatment the bullion will contain about 0.05% copper, but this can be reduced to as low as 0.005% by adding sulfur.

Next, the bath temperature is raised to about 1400 F (750 C), and air is admitted to produce oxidizing conditions. Some of the lead and most of the antimony and arsenic thus are oxidized and unite with some added litharge to form a slag rich in lead. Tin also will oxidize if it is present. After 12 hr at temperature nearly all the antimony and arsenic and the last of the copper have been removed. Bismuth cannot be removed by oxidation.

In the presence of alkali salts (preferably NaOH plus NaCl) and an oxidizer, the arsenic and antimony can be removed as sodium arsenate or antimonate at temperatures as low as 880 F (470 C).

#### THE PARKES PROCESS FOR DESILVERIZATION

The Parkes process<sup>12</sup> for separating gold and silver from lead is based upon three facts:

1. In an alloy of lead, gold, silver, and zinc, the zinc forms intermetallic compounds preferentially, first with the gold ( $\text{Au}_2\text{Zn}_3$ ) and then with the silver ( $\text{Ag}_2\text{Zn}_3$ ).
2. These compounds have higher melting points and lower specific gravities than lead, and hence tend to float, as solids, on it.
3. The compounds are virtually insoluble in lead that is saturated with zinc.

The process is carried out in kettles holding about 100 tons. Zinc is added to the molten bullion in sufficient amount to combine with the noble metals and to saturate the lead. For several hours thereafter the temperature is maintained at about 900 F (480 C). As the lead is stirred, the crust rises to the surface and is skimmed off for treatment to recover silver, gold, and zinc. When the silver content is reduced to about 0.25 oz per ton, the desilverized lead is sent to the refining stage for *dezincing*.

#### DEZINCING BY REFINING

Refining<sup>13</sup> usually is carried out in a 300-ton shallow-hearth reverberatory furnace. The lead is held for 12 hr at a temperature of about 1400 F (750 C) while it is agitated and oxidized either by air or steam blown through it or by the addition of lead oxide. The zinc, together with a large amount of lead, will be oxidized and rise to the surface to be skimmed off. The lead is now sufficiently soft to be cast into pigs for market.

#### DEBISMUTHIZING WITH CALCIUM AND MAGNESIUM

Since *corroding* lead, which is used in the manufacture of pigments, must not contain more than 0.05% bismuth, this element sometimes must be removed. This can be done by treating the desilverized and refined lead with calcium and magnesium<sup>14</sup> at about 800 F (425 C). The lead first

<sup>12</sup> See also A. J. Beasley, *Trans. A.I.M.E.*, Yearbook, 1930, 265-271.

<sup>13</sup> Some dezincing also is done with chlorine as described by J. O. Betterton, *Trans. A.I.M.E.*, **121**, 1936, 264-270.

<sup>14</sup> See also J. O. Betterton and Y. E. Lebedeff, *Trans. A.I.M.E.*, **121**, 1936, 205-225.

forms a compound with the calcium,  $Pb_3Ca$ , and this probably forms a complex compound with the bismuth and magnesium, thereby producing a dross which may contain as high as 20% bismuth. Less than 0.05% bismuth is left in the metal. This process also removes the last traces of antimony, arsenic, copper, and silver, but does not affect tin.

#### THE BETTS ELECTROLYTIC PROCESS

If lead of very high purity is desired, and particularly when the impure lead contains more than about 1% bismuth, the Betts electrolytic process is used.<sup>15</sup>

Cast anodes of lead bullion and cathodes of pure lead are suspended in an electrolyte of lead silica fluoride (fluosilicate) and hydrofluosilicic acid. Temperatures run about 110 F (45 C). The electrical arrangement is similar to that used in the multiple system of copper refining.

A current density of 15–18 amp per sq ft is used with a potential drop of about 0.5 v between electrodes.

The lead cathodes are remelted and cast into bars for market and the anode muds are refined for their arsenic, antimony, bismuth, and precious-metal contents. The electrolyte is purified periodically to prevent contamination.

Although the cost of electrolysis is generally greater than that of desilverization with zinc, the Betts process yields a very high percentage of high-grade refined lead, free from bismuth. In addition it recovers the bismuth. Except for very high-grade lead used for the manufacture of white lead for the paint industry, however, and for lead running very high in bismuth, the Parkes process is more economical than the Betts process, and is used much more widely.

#### HYDROMETALLURGICAL PROCESSES

The relatively difficult process of concentrating lead ores as well as the smelting and refining stages could be eliminated completely by the use of the more direct methods of leaching and electrodeposition. By such a method low-grade lead ores, as well as lead-bearing tailings from other metallurgical processes, could be treated readily. Unfortunately, however, none of the various suggested processes has passed the pilot-plant stage, and a commercially feasible method still is being sought.

<sup>15</sup> For additional information see P. F. McIntyre, *Trans. A.I.M.E.*, **121**, 1936, 271–284; and T. E. Harper, Jr. and Gustave Reinberg, *ibid.*, 284–288.

## VOLATILIZATION PROCESSES

If copper, gold, lead, or silver are given a chloridizing roast at about 1900 F (1050 C), their chlorides are volatilized and can be recovered from the fumes produced, either in bag houses or by the use of Cottrell electrostatic precipitators. The dust so collected then can be dissolved in water and the metal precipitated by either electrolysis or cementation.

## THE WAELEZ PROCESS

Low-grade ores and residues can be recovered by a method<sup>16</sup> similar to that used for zinc by mixing them with a solid carbonaceous reducing agent and then treating them in a horizontal rotary kiln in which they are both dried and heated by hot gases flowing in the opposite direction. The strong reducing atmosphere produced within the charge at the temperature of operation frees and volatilizes the metals. The oxidizing atmosphere above the charge in the kiln then reoxidizes the escaping metallic vapors. The oxides formed can be collected in bag houses, or Cottrell precipitators as before, for recovery of the lead or other volatile metal contents.

## COMMERCIAL PIG LEAD

Seven grades of pig lead are covered by A.S.T.M. Standard B29. The specified chemical compositions of the three most important are given in Table XVI.

TABLE XVI A.S.T.M. PURITY SPECIFICATIONS FOR THREE IMPORTANT GRADES OF LEAD

	% PB (MIN) (BY DIFF.)	% AG (MAX)	% CU (MIN) (MAX)	% ZN (MAX)	% FE (MAX)	% BI (MAX)	% AS (MAX)		
Corroding lead	99.94	—	0.0015	—	0.0015	0.0015	0.002	0.05	0.0015*
Chemical lead	99.90	0.002	0.02	0.040	0.080	0.001	0.002	0.005	0.002†
Common desilver- ized lead A	99.85	—	0.002	—	0.0025	0.002	0.002	0.15	0.015†

\* Sb and Sn together 0.0095% max.

† Includes Sb and Sn.

<sup>16</sup> See also W. E. Harris, *Trans. A.I.M.E.*, 121, 701-720.

Acid lead, copper lead, common desilverized lead B, and soft undesilverized lead, are the other grades covered.

## *Tin*

### ORES OF TIN

Most of the world's tin production has been under the control of a cartel comprising seven governments and known as the *International Tin Committee*. Nearly one third of the world's tin supply was produced in the Straits Settlements (Malaya) and most of the remainder in the Netherlands East Indies, Bolivia, Siam, Nigeria, Belgian Congo, and China. The geographical relationships of these main sources to the United States market, the principal consumer, can be comprehended readily.

The only important ore of tin is the mineral *cassiterite* ( $\text{SnO}_2$ , containing 78.6% tin when pure). Although high-grade ores seldom are found, water-gravity concentration is simple because of the mineral's high specific gravity (6.4–7.1). Usually ores will contain less than 8% tin whereas the standard concentrate contains 60% tin.

### IMPURITIES IN TIN ORES AND THEIR REMOVAL

Compounds of antimony, bismuth, copper, iron, lead, and zinc, frequently sulfides, commonly are found associated with cassiterite. These generally cannot be removed entirely by water-gravity concentration, although separation by differential flotation methods is fairly efficient. By roasting the concentrates at about 1100 F (550–650 C) most of the sulfur is removed and most of the impurities are converted to the oxide or chloride form in which they can be removed by leaching with dilute acid.

### BLAST-FURNACE SMELTING

Tin oxide is reduced readily by carbonaceous material when heated at a fairly low temperature. The usual blast furnace is quite similar to that used for lead ores although somewhat lower shafts and blast pressures are used. Complications result, however, because tin oxide combines so readily with silica to form tin silicates. Blast-furnace slags, therefore, frequently will contain 10–25% tin, despite the ease of reduction of the oxide to the metal. If basic slags are used, furthermore, tin oxide, because of its ability to act as either an acid or a basic oxide depending on external conditions, goes into the slag to about the same extent.



The slag is retreated, usually in reverberatory furnaces, to reduce its tin content. The metal, on the other hand, either may be cast into pigs or slabs for market or else refined to a higher purity.

#### REVERBERATORY-FURNACE SMELTING

A better tin recovery is possible in the reverberatory furnace than in the blast furnace, not only because the slags tend to contain less tin, but also because dust and similar losses are reduced.<sup>17</sup>

The usual furnace will treat about 10 tons of a charge made up of tin concentrates mixed with 15–20% of anthracite screenings and the necessary fluxing materials (sand, limestone, slag, etc.). The process is a batch operation carried out for 10–12 hr at 2200–2400 F (1200–1300 C). A very pure grade of tin is produced along with a comparatively high-tin-content slag (10–25% tin). This slag is cooled, crushed, and later retreated at a much higher temperature, and in the presence of more reducing agent, flux, and scrap iron to decompose the tin oxide. If a slag containing less tin is desired, a metal of lower purity will result.

The metal either is cast into 75-lb pigs for marketing or else refined further.

#### REFINING BY PYROMETALLURGICAL METHODS

Even though some refining is possible, the purity of tin actually is determined to a considerable extent by the nature and source of the original ore. The Bolivian ores, in particular, are rather impure, and hence it is comparatively difficult to secure a pure grade of tin from them. Refining difficulties also result from the large amount of tin that is lost as oxide whenever impurities are oxidized.

In the usual fire refining of tin, as shown by the simplified flow sheet in Fig. 171, the method of *liquating* or *sweating* is used first. The object of this process is to remove from the tin all impurities having appreciably higher melting points and lower specific gravities. The process usually is carried out in a comparatively small reverberatory furnace, the hearth of which slopes from one side toward a large taphole on the other side. Through this taphole molten tin runs and can be collected. Slabs or bars of tin are placed on the hearth and the temperature is raised very slowly to just above the melting point of the metal, 450 F (232 C), so that the clean tin runs slowly through the taphole into kettles, leaving the solid residue on the hearth.

<sup>17</sup> See also "Recent Progress in Tin Smelting and Metallurgy" by C. L. Mantell: *Trans. A.I.M.E.*, **159**, 1944, 18pp.

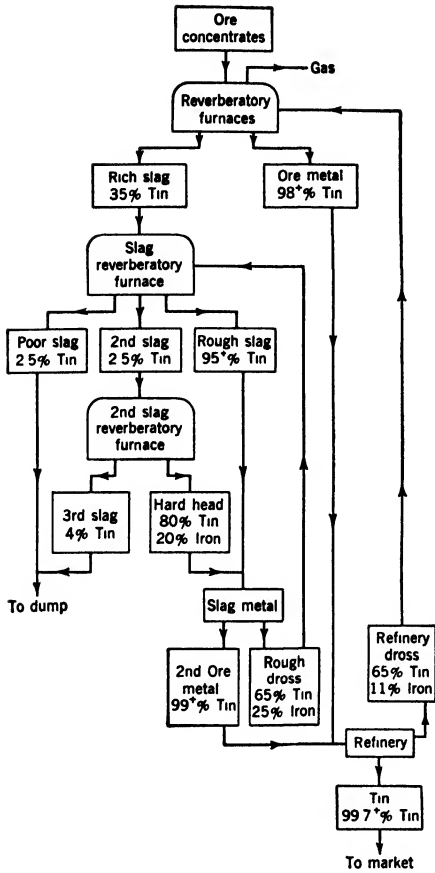


FIGURE 171. Simplified flow sheet illustrating the extraction of tin from its ores and its refining for commercial use.

The dross remaining in the furnace after the pure tin is gone then is reheated by raising the temperature still higher and collected for retreatment with the next charge.

Bismuth and lead, because of their low melting points, will go with and remain in the sweated tin along with a little iron. Most of the iron, however, along with much of the antimony, arsenic, and copper will remain in the dross. The degree of separation that is possible, in addition, will depend upon the type of alloy diagram formed between tin and its various impurities, as can be appreciated better later.

The first *sweat-tin* can be purified further if desired by *boiling*. Essentially this consists of heating it in kettles holding about 8 tons of metal, and poling it with green wood as in the refining of copper. Compressed air also may be used. The steam and gases given off produce a strong bubbling action in the bath, and when the metal comes in contact with the air, some of the impurities

and much of the tin will be oxidized and skimmed off as a dross to be re-sweated or resmelted. This operation may be continued for several hours.

ELECTROLYTIC REFINING

Tin can be electrodeposited satisfactorily from several solutions the best of which contain either 15% of hydrofluosilicic acid, 0.1% of sulfuric acid, and 4% of stannous tin, or about 8% of sulfuric acid, 4% of cresol-phenol sulfonic acid, and 3% of stannous tin. A current density of about 10 amp per sq ft with a voltage of 0.2 or less is used in a solution held at a temperature of 65 F (20 C). For successful operation, the process must be controlled carefully. An electrolytic tin analyzing better than 99.98%, however, can be produced if care is taken.

The anode slimes formed will contain any antimony, arsenic, bismuth, copper, gold, lead, or silver, as well as some tin. They can be treated further to remove these metals if any of them are present in sufficient amount to make it economical to do so.

#### COMMERCIAL TIN

Since practically all the tin used in the United States is imported no A.S.T.M. Standards covering it have been written. In the 3-yr period 1936-38 the percentage distribution of the various brands used was about:

---

Straits	76.6%
English refined	8.0%
Chinese	5.5%
Banka	4.5%
Tulip	4.0%
Katanga	1.0%
Others	0.4%

---

During World War II, the Katanga brand was the only one of these still available from other than stockpile sources.

Straits tin usually ran low in antimony (0.003-0.004%) and was preferred for tin-plate manufacture because of its resulting supposedly better appearance and flow characteristics.

Typical percentage analyses of some of the common brands are listed in Table XVII.

TABLE XVII TYPICAL CHEMICAL ANALYSES OF SOME OF THE COMMON BRANDS OF TIN

---

BRAND	SMELTING COUNTRY	% SN	% PB	% SB	% CU	% AS	% FE	% BI
Chempur	England	99.986	0.0082	0.0032	0.0007	0.0001	0.0005	0.0009
Banka	N. E. I.	99.983	0.0001	0.0101	—	trace	0.0064	—
Penpoll Special								
Refined	England	99.925	0.038	0.005	0.0102	0.009	0.004	0.004
Straits	Straits Settlements	99.895	0.029	0.004	0.025	0.031	0.009	0.007
Tulip	Holland	99.870	0.038	0.041	0.006	0.031	0.009	0.003
Wing Hong								
No. 1	China	99.343	0.434	0.031	0.054	0.040	0.010	0.007
Mellanear								
L. & F.	England	99.206	0.468	0.136	0.081	0.065	0.006	0.012

---

*For Further Study Refer to*

1. *Non-Ferrous Production Metallurgy*, by John L. Bray: John Wiley & Sons, Inc., New York, 1941.
2. *An Outline of Metallurgical Practice*, 2d ed., by Carle R. Hayward: D. Van Nostrand Company, Inc., New York, 1940.
3. *The Mineral Industry*, edited by G. A. Roush: McGraw-Hill Book Company, Inc., New York (published annually).
4. *Minerals Yearbook*: U. S. Dept. of the Interior, Bureau of Mines (published annually).
5. *Handbook of Non-Ferrous Metallurgy*, 2d ed., edited by Donald M. Liddell: McGraw-Hill Book Company, Inc., New York, 1945.
6. *Copper Metallurgy*, Rocky Mountain Fund Volume: *Trans. A.I.M.E.*, 103, 1933.
7. *Metallurgy of Copper*, by J. Newton and C. L. Wilson: John Wiley & Sons, Inc., New York, 1942.
8. *Metallurgy of Lead and Zinc*, Rocky Mountain Fund Volume: *Trans. A.I.M.E.*, 121, 1936, 1-338.
9. *Tin*, by C. L. Mantell: The Chemical Catalog Company, Inc., New York, 1929.
10. *Transactions American Institute of Mining and Metallurgical Engineers*, Non-Ferrous Metallurgy Division: A.I.M.E., New York (published annually).

## THEORY VS. EXPERIMENT

THE STUDY OF ALLOYS IS A COMPLEX ONE. HOWEVER, THIS complexity arises primarily from the fact that so little has been uncovered about the fundamental principles upon which the subject is based. In our present state of knowledge, indeed, only an expert can do much more than guess about the results that can be expected when two or more metals are alloyed together. Consequently, predictions are all but impossible for the average user of metals, and trial-and-error experimental methods must be used necessarily. Fortunately the work that already has been done by others can be interpreted readily and used if certain fundamentals are well understood. Such an understanding is all that reasonably can be expected of an engineer as his problem is one of application rather than development.

## LIQUID SOLUTIONS

The concept of a liquid solution is usually not too difficult to grasp because it is encountered so frequently. When one or more pure solids dissolve in a pure liquid *solvent*, or when two or more pure liquids dissolve in each other, it is known that the resulting liquid solution (*a*) must contain both solvent and solute, (*b*) will have properties differing from those of any of the pure materials to an extent which is dependent on the nature and amount of each present, (*c*) readily can be made quite uniform because of the comparatively rapid diffusion and ease of mixing of liquids. If the *solute* used is a solid, it will be found in addition that it can dissolve at temperatures well below its own melting point. Therefore, it must exist in a new form in solution.

These general statements concerning liquid solutions are independent of the temperature, and hence are as valid for molten metals as for substances like water, which are more familiar because they are liquid at room temperature.

## COMPONENTS

In discussing alloys, it is useful to refer to the different atomic types involved as the components of the alloy, a definition which usually means that each component is a different chemical element. Although this is not in strict accord with the customary definition of physical chemistry<sup>1</sup>—*the least number of independently variable substances required to express the composition of each phase of a system*—it is somewhat more convenient for use with alloys, in which the exact nature of compounds is not always so clearly defined as it is in chemistry. If there are two components, the alloy is known as a *binary* alloy; if three, a *ternary*; if four, a *quaternary*; etc. The binary alloys will receive the most attention in the following discussion.

## METHODS OF ALLOYING

There are three general methods of alloying by forming a liquid solution as the first step:

1. The components each can be melted and then mixed.
2. The higher melting components can be melted, and the lower melting ones added as solids.
3. The lower melting components can be melted, and the higher melting ones added as solids.

In each case some adjustment of the temperature may be required to keep the alloy in the liquid state until complete solution occurs. The reasons for this will be clearer after further discussion.

The last two are the preferred methods. Any choice between them depends upon the general characteristics of the dominant metal present.

## POWDER METALLURGY

In addition to these three methods of alloying by first forming a liquid solution there is a fourth method,<sup>2</sup> developed in the 1930's although it was known much earlier, for making solid alloys at temperatures which may be well below their melting points. If powdered components of the proper shape and degree of fineness are mixed intimately, compressed, and then sintered, i.e., heated at temperatures near but usually well below the melt-

<sup>1</sup> See, for example, *The Phase Rule and Its Applications*, 7th ed., by A. Findlay: Longmans, Green and Company, New York, 1931; or *Principles of Phase Diagrams*, by J. S. Marsh: McGraw-Hill Book Company, Inc., New York, 1935.

<sup>2</sup> See *Powder Metallurgy*, edited by John Wulff: Amer. Soc. for Metals, Cleveland, Ohio, 1942; *Powder Metallurgy Conference*: Mass. Inst. of Tech., Cambridge, Mass., 1940.

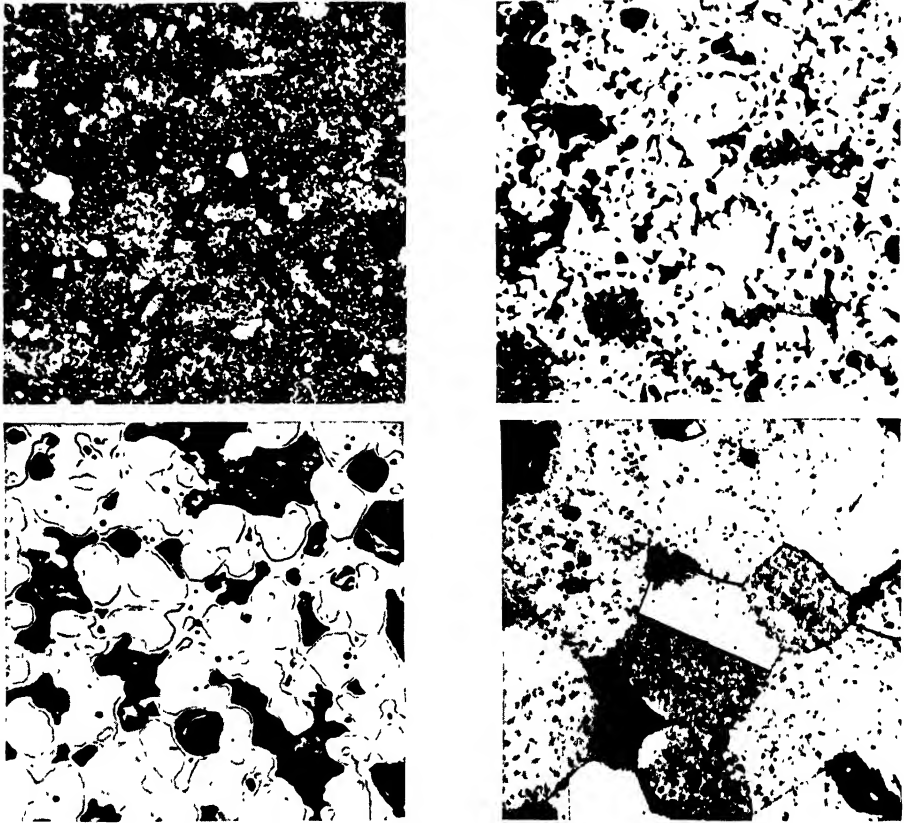


FIGURE 172. Metallographic structure of a porous bronze bushing made by powder metallurgical methods. Composition 88% Cu — 10% Sn — 2% C (graphite). Etched with  $\text{NH}_4\text{OH} + \text{H}_2\text{O}_2$ .  $\times 100$ . (Photomicrographs by L. Litchfield.)

*a. (Upper left)* As compacted under 50 tons pressure. The fine particle size of the powder is apparent.

*b. (Upper right)* After heating compact in hydrogen for 1 hr at 1400 F (760 C). Some free tin and graphite in an  $\alpha$ -bronze matrix. The dark areas are largely porosity.

*c. (Lower left)* After heating compact in cracked gas for 15 min at 1600 F (870 C) and oil-quenching. Diffusion of tin at higher temperature has produced an  $\alpha$ - $\beta$  bronze matrix. The dark regions are largely porosity. This structure is rather abnormal since the  $\beta$  phase is unstable at room temperature and tends to transform to  $\alpha$  and  $\delta$  during cooling. The cooling rate used was probably too rapid to permit this transformation to occur.

*d. (Lower right)* After heating compact in cracked gas for 15 min at 1600 F (870 C) and furnace cooling. The structure shows  $\alpha$  bronze containing particles of  $\delta$  precipitated during cooling.

ing point of the dominant metal involved, they will form a coherent, compact mass which may be considered to be an “alloy” even though, under the definition given above in which initial liquid solution is deemed to be essential, no alloying is possible. By using the methods of powder metal-

lurgy any metals can be "alloyed" to some extent although the resulting mass may require quite complicated treatments to make it even approximately homogeneous. Three stages in this process are illustrated in Fig. 172 for a commercial bearing-alloy, which was not, however, sintered in strict accord with commercial practice.

The temperature range in which sintering can be carried out, and the time required, depend upon the metals involved, and may be such that one or more of the components is liquid, or such that all of them remain solid. By this process, it is also possible to make alloys of any desired degree of porosity simply by controlling properly the pressure and the sintering time and temperature.

Powder metallurgy made possible the original production of ductile tungsten,<sup>3</sup> and since has facilitated even more startling industrial developments, such as "oil-less" bearings, metal filters for oil and gasoline, lightweight metal gears, and several varieties of metal carbide and diamond impregnated cutting and grinding tools. The process is discussed in greater detail in Chap. X.

#### DIFFUSION

The methods of powder metallurgy are successful only because of the interrelated phenomena of pressure welding and interatomic diffusion.<sup>4</sup> Although the different atoms in a solid alloy oscillate around certain mean positions on a geometrical space lattice just as those of a pure metal do, the mobilities of the different components will vary appreciably. Increasing the temperature will cause a still greater difference in these atomic mobilities. This increased temperature will manifest itself by an increase in the amplitude and frequency of atomic vibration. With so many atoms present, there are always some which will have sufficient mobility to enable them to leave their equilibrium positions, pass to new positions, possibly by changing places with other atoms or in some other manner, and thus to progress through the lattice. An increase in temperature facilitates these changes, and increases the frequency at which they occur. This movement of atoms through a space lattice is known as diffusion. It occurs regardless of whether the diffusing atoms are similar to or different from the solvent or host atoms.

In general, diffusion is more rapid the greater the difference in characteristics between the two kinds of atoms, the higher the temperature, and the greater the concentration gradient. In every case diffusion tends to

<sup>3</sup> See *Tungsten*, 2d ed., by Colin J. Smithells: D. Van Nostrand Company, Inc., New York, 1936; also P. E. Wretblad, Chap. 38, in Ref. 10 at the end of this chapter.

<sup>4</sup> See R. F. Mehl, *Trans. A.I.M.E.*, **122**, 1936, 11-56.



assist in attaining equilibrium, i.e., to make the alloy more homogeneous by removing definitely the concentration gradients, and, probably, also the strain and thermal gradients. Similar, although possibly less complex, phenomena occur in the liquid and gaseous states.

### PHASES

The components of a binary alloy are limited in the ways in which they can combine. Each of these combinations which is, or would be under conditions approximating equilibrium, *homogeneous*, *mechanically separable*, and *bounded by a surface* will be called a phase. In general, each phase will have its own unique set of characteristics, and thus will influence the over-all characteristics of the alloy to an extent determined by the amount present and the manner in which it is dispersed.

The composition of a phase need not be constant. It can vary over wide limits. However, in the solid state, and probably in the liquid state also although there is little definite information available concerning this, each phase will have a characteristic atomic arrangement which may have continuous, but not discontinuous, variations in it, i.e., the spacings and number of the different atoms present can vary continuously through the composition range of stability, and for this reason the properties will vary continuously also.

### EQUILIBRIUM DIAGRAMS

The diagrams which are used to express the relationships between phases *under conditions of equilibrium* are known as phase- or equilibrium diagrams.<sup>5</sup> However, if the strictest terminology is not adhered to, and it need not be here, the more general term of *constitutional diagram* may be preferable. For binary alloys, these diagrams are two dimensional plots of temperature as ordinate vs. composition as abscissa as indicated in Fig. 173. For ternary alloys, they are three dimensional, the temperature axis usually being plotted vertically either from an equilateral triangular base, each corner of which indicates 100% of one of the components as shown in Fig. 174; or from a right triangular base as in Fig. 175. More complex alloys, obviously, can be represented in three dimensions only by fixing certain of the variables.

The composition axis may be plotted in a number of different ways although percentage by weight is most common as well as most convenient from a practical viewpoint.

<sup>5</sup> See Ref. 3 at end of this chapter.

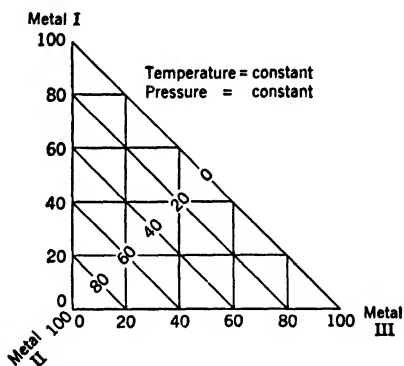
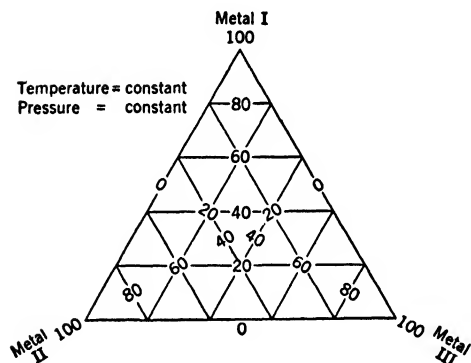
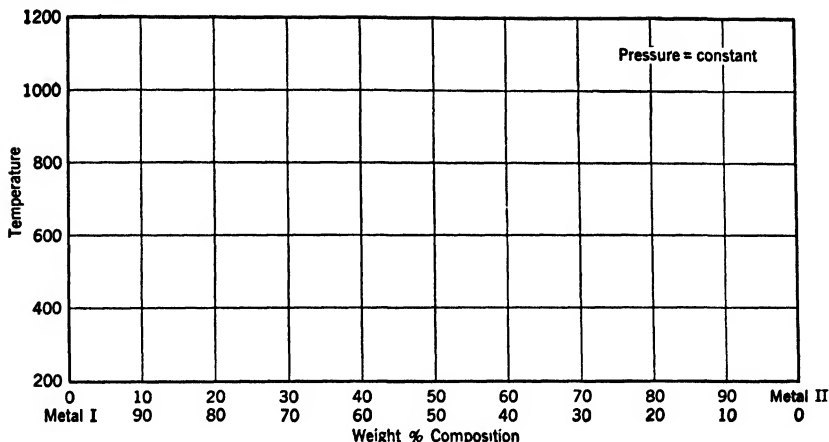


FIGURE 173. (*Upper*) Schematic method of plotting binary constitutional diagrams. The pressure is considered to be constant.

FIGURE 174. (*Lower left*) Schematic method of plotting ternary constitutional diagrams from an equilateral triangular base. In a two-dimensional representation, as shown, both the temperature and the pressure are considered to be constant. In three dimensions, the temperature usually is plotted normal to the base, and the pressure is considered to be constant.

FIGURE 175. (*Lower right*) Schematic method of plotting ternary constitutional diagrams from a right triangular base. In a two-dimensional representation, as shown, both the temperature and the pressure are considered to be constant. In three dimensions, the temperature usually is plotted normal to the base, and the pressure is considered to be constant.

In equilibrium relationships, there are actually three variables: *temperature*, *pressure*, and *concentration*. However, in metallurgical work the vapor pressures of the components are usually so small that pressure customarily is considered to remain constant at 1 atm; hence, the use of a temperature-concentration diagram. In the subsequent discussion, the vapor phase

will be omitted from consideration entirely, even though for certain alloys this variable must be considered and the relatively complicated pressure-temperature-concentration diagrams should be used instead of the relatively simple temperature-concentration diagrams.

Data from which to plot equilibrium diagrams can be secured by any method which will indicate changes in the equilibrium state of the alloy. Determinations of the variation with temperature of the physical properties, e.g., electrical conductivity, heat content, specific heat, or thermal expansion, are used most frequently, although methods involving microscopic examination or X-ray structure analysis are also common.<sup>6</sup>

The general methods for securing *thermal data* already have been discussed under the pure metals in Chap. II.

#### TYPES OF PHASES IN BINARY ALLOYS

In addition to the liquid solution, there are only four basic types of solid phases known to exist in binary alloys. These will be given the general group names:

1. Primary or terminal solid solution
2. Commercially pure metal
3. Intermetallic compound
4. Secondary or intermediate solid solution

Two components can combine to form more than one example of a given type, but only the four general types are known. It must be realized, however, that this is merely a convenient method of classification. If some other basis were used, such as type of atomic binding, for example, a different grouping probably would result.

#### PRIMARY OR TERMINAL SOLID SOLUTION

The only real difficulty introduced by the concept of a solid solution rather than a liquid solution is that there is a certain rigidity in the solid state which to many minds is incompatible with the concept of a solution. A pure metal, as has been mentioned already, possesses a characteristic space lattice, usually a relatively simple one. When it acts as a solvent to form a solid solution with another metal or nonmetal, the foreign or solute atoms either must replace atoms of the solvent metal on its own space lattice, thus giving a *substitutional* solid solution; or else take up positions

<sup>6</sup> See K. R. Van Horn, *Symposium on Radiography and X-ray Diffraction Methods*: A.S.T.M., Philadelphia, Pa., 1936, 230-284.

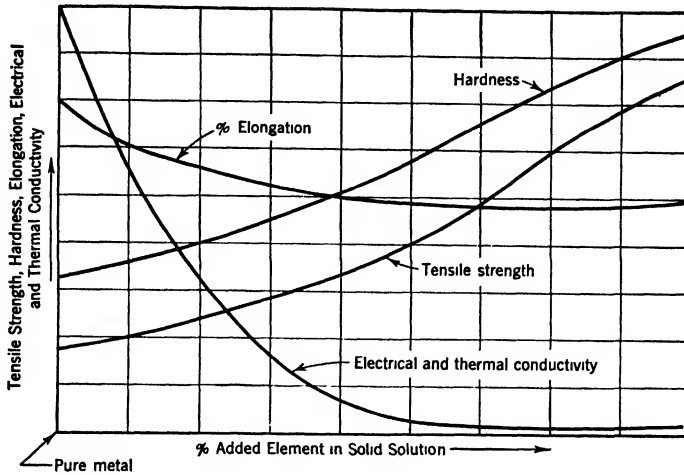


FIGURE 176. Diagrammatic illustration of the general change of properties with composition in alloys which are solid solutions. Cf. Fig. 188c.

between these atoms, giving an *interstitial* solid solution. In general, the solute atoms must be quite similar to those of the solvent, in both size and characteristics, if they are to form a substitutional solution; and they must be very small, such as those of nitrogen and carbon, to form an interstitial solution.

The solute atoms, as far as is known now, can take up any position on the solid-solution lattice with complete freedom of choice. This is known as a random arrangement of atoms. Because the components of the solid solution are dispersed atomically in a random manner they can not be distinguished under the microscope. The alloy is *statistically* homogeneous and appears to be perfectly so.

Because the space lattice of the primary solid solution is the same as that of the pure metal, except that it changes continuously in size as more of the foreign atoms dissolve, the properties of the solution will change continuously from those of the pure metal. In general, the addition of elements in solid solution will result in an increase in strength and hardness, and a decrease in workability and electrical and thermal conductivity as indicated schematically in Fig. 176. The chemical properties, such as corrosion resistance, depend on the individual alloys, sometimes increasing and sometimes either decreasing or remaining nearly unchanged.

Under the microscope it is impossible to differentiate with certainty between a primary solid solution and the pure metal upon which it is based. This can be seen readily by comparing the photomicrographs shown in Fig. 177 and 178. Only high-precision X-ray diffraction studies will

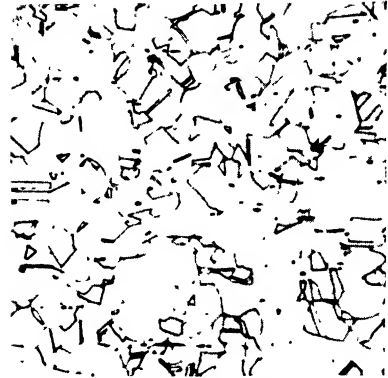
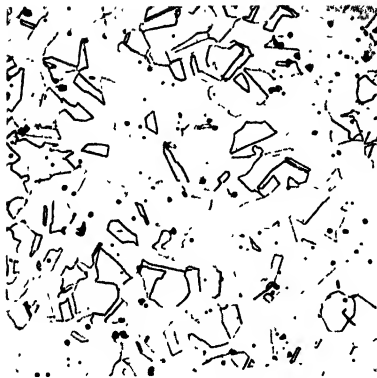


FIGURE 177. (Left) Metallographic structure of worked and annealed Monel metal, a primary solid solution containing approximately 70% Ni – 30% Cu. Etched with nitric and acetic acids.  $\times 100$ . (Photomicrograph by L. Litchfield.)

FIGURE 178. (Right) Metallographic structure of worked and annealed commercially pure nickel. Etched with nitric and acetic acids.  $\times 100$ . Cf. Fig. 443 where a contrast etch rather than a flat etch has been used. (Photomicrograph by L. Litchfield.)

show the change in the size of the pure metal space lattice as foreign atoms “dissolve” in it.<sup>7</sup>

In a constitutional diagram any field in which a primary solid solution is the only stable phase would be represented as a terminal area as indicated in Fig. 179.

#### COMMERCIALY PURE METAL

There are probably no cases of complete insolubility in the solid state. A restricted number of foreign atoms always can enter the space lattice of any metal, either substitutionally or interstitially. As a result, the “pure” metal exists in theory only. However, any linear means of plotting alloy compositions must have a definite scale. A commercially pure metal, therefore, will be defined and considered as a *primary solid solution whose composition range is too limited to be shown on the composition scale used*. On a constitutional diagram, consequently, a commercially pure metal would appear as a terminal *line* as indicated in Fig. 180, rather than a terminal *area*, and may be considered to be the limiting case of a primary solid solution. Any real differentiation between these two types of phases must be purely arbitrary as they differ actually only in degree of purity.

The physical and mechanical properties of a commercially pure metal will differ somewhat from those of high-purity metal depending on the

<sup>7</sup> For a further discussion of this, see C. S. Barrett, *Symposium on Radiography and X-ray Diffraction Methods: A.S.T.M.*, Philadelphia, Pa., 1936, 193–229.

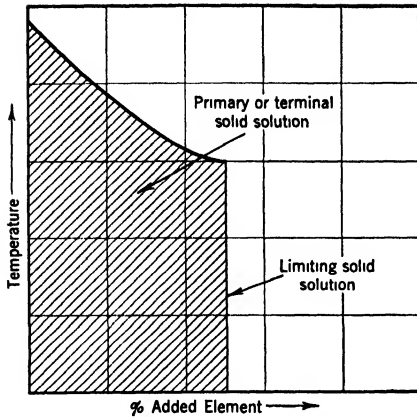


FIGURE 179. (Left) Schematic representation of a primary or terminal solid solution on a binary constitutional diagram.

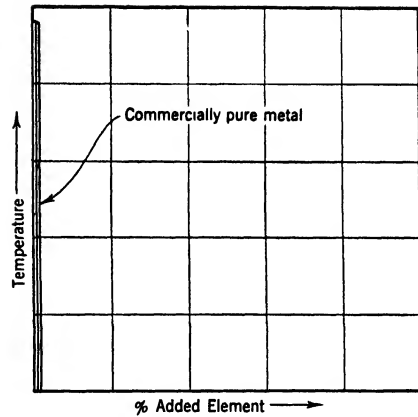


FIGURE 180. (Right) Schematic representation of a commercially pure metal on a binary constitutional diagram.

specific impurity present. In general, however, the difference will not be too great. The commercially pure metal, like the "pure" metal, will be comparatively soft and weak with fairly good workability and conductivity, although in many cases, such as zinc for example, the presence of certain impurities may improve workability appreciably.

Under the microscope, the structure of the commercially pure and the high-purity metals should be practically identical, differing, if at all, only in the size of their grains or in the nonmetallic inclusions. This would be expected from a comparison of the photomicrographs in Figs. 177 and 178, and is shown specifically for copper in Fig. 163.

#### INTERMETALLIC COMPOUND

In many respects, intermetallic compounds are similar in nature to chemical compounds. Both have definite compositions, definite and individual properties and characteristics, and melt or decompose at definite temperatures, either congruently, to a single liquid phase, or incongruently, to a mixture of two phases. However, intermetallic compounds differ from chemical compounds in one very important respect in that they rarely obey the laws of chemical valence, whereas chemical compounds invariably do. A certain amount of theoretical study on intermetallic compounds<sup>8</sup> has indicated that the structure of at least some of them is determined by

<sup>8</sup> For a further discussion see: *The Structure of Metals and Alloys* by W. Hume-Rothery: The Inst. of Metals, London, 1936.

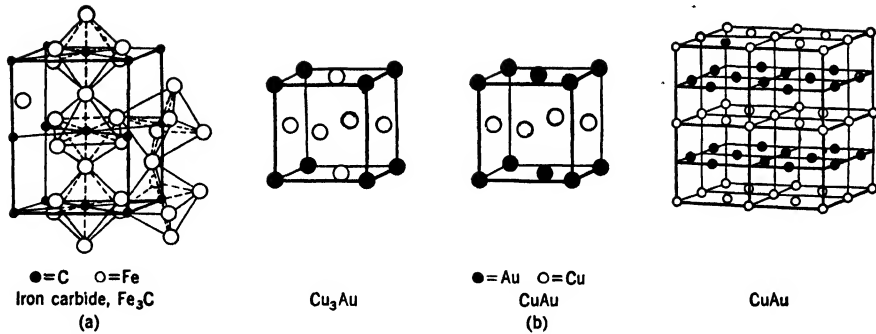


FIGURE 181. Probable atom arrangements in three typical intermetallic compounds. *a.* Iron carbide, Fe<sub>3</sub>C. (After S. B. Hendricks.) *b.* The copper-gold compounds, Cu<sub>3</sub>Au and CuAu.

the ratio of the sum of the valence electrons of the atoms involved to the number of atoms in a unit cell. Many compounds, however, still have not been rationalized on this basis.

Intermetallic compounds have characteristic, and frequently unique, space lattices which are usually complex in nature. Research has indicated that it is common, in these space lattices, to find certain positions occupied by certain types of atoms. As a result, under this definition we would class as intermetallic compounds not only compounds with complex structures, such as iron carbide, Fe<sub>3</sub>C, shown in Fig. 181*a*, but also structures such as the copper-gold compounds, Cu<sub>3</sub>Au and CuAu (Fig. 181*b*), which differ from a primary solid solution only in the regularity of arrangement of their atoms, and hence sometimes are called *ordered* solid solutions in contrast to the *disordered* or *random*<sup>9</sup> arrangement of the true primary solid solution in which the positions of the atoms on the space lattice are determined by chance.

Because of their complex structures, and of the forces between the unlike atoms whose positions are interrelated so definitely, intermetallic compounds generally are characterized by a high hardness and brittleness at atmospheric temperatures, and by a high melting point, when they melt to form a single liquid phase. Compounds whose melting points are higher than those of either of their components frequently are found, although this rule is by no means general. Because of their high hardness and brittleness, intermetallic compounds themselves seldom are found in commercial alloys except as minor constituents. In many alloys, however, these minor constituents are responsible for their most important engineering proper-

<sup>9</sup> For a further discussion of this subject see: F. C. Nix and W. Shockley, *Rev. Modern Physics*, 10, 1938, 1.

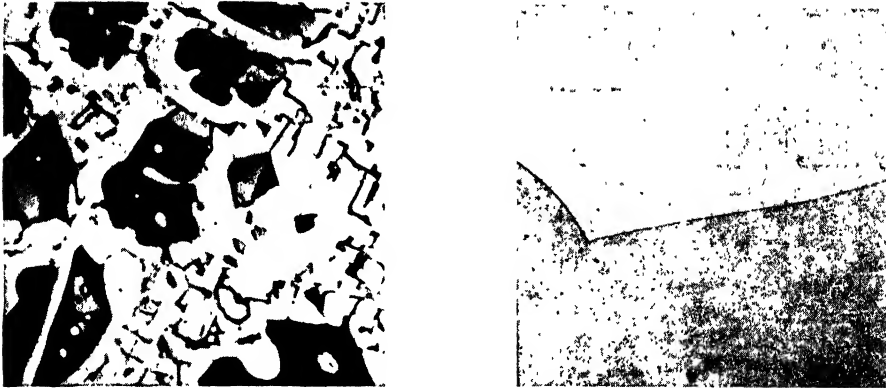


FIGURE 182. Metallographic structures of a typical intermetallic compound and a secondary solid solution.

- a. (Left)* Crystals of the intermetallic compound  $Mg_2Si$  in an alloy of 68% Al – 20% Mg – 12% Si. Etched with  $\frac{1}{2}\%$  HF.  $\times 500$ . (Photomicrograph by L. H. Houtz.)
- b. (Right)* Crystals of the  $\beta$  secondary solid solution in an alloy of 55% Cu – 45% Zn after quenching from 1475 F (800 C). Etched with  $NH_4OH + H_2O_2$ .  $\times 100$ . (Photomicrograph by A. J. Calpaxis.)

ties. Knowledge concerning the actual strength of compounds is inconclusive. Although their strengths are believed to be comparatively high, the brittleness of most of them prevents accurate measurement since failure tends to be in shear rather than in tension. Their electrical resistance is frequently surprisingly low.

Under the microscope, intermetallic compounds would appear, of course, as an aggregation of uniform crystallites, each exactly like the others, and, except for variations in shape and size, indistinguishable from them. This is typified by the large dark particles in Fig. 182*a*. By metallographic examination alone, therefore, it would be practically impossible to distinguish between a pure metal, a primary solid solution, and an alloy which was composed completely of an intermetallic compound.

The resistance of intermetallic compounds to the corroding effects of certain reagents is frequently exceptional, but they rarely are used commercially to resist corrosion because of other difficulties, usually connected with fabrication, although casting can be used to overcome this in some instances.

In a constitutional diagram an intermetallic compound would be indicated by a vertical line as in Fig. 183, i.e., a definite composition containing both components. However, all vertical lines need not designate compounds, as will be seen shortly.



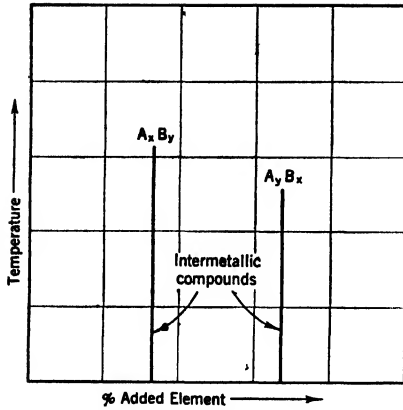


FIGURE 183. (Left) Schematic representation of two intermetallic compounds on a binary constitutional diagram.

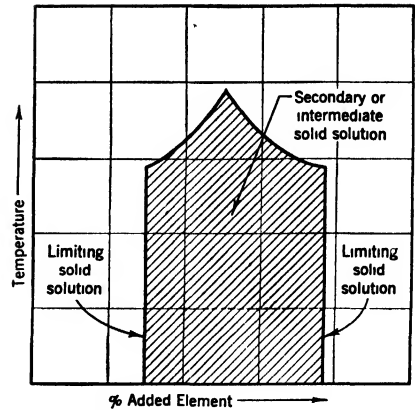


FIGURE 184. (Right) Schematic representation of a secondary or intermediate solid solution on a binary constitutional diagram.

#### SECONDARY OR INTERMEDIATE SOLID SOLUTIONS

Just as with pure metals and some chemical compounds, intermetallic compounds frequently have the ability to replace one type of atom in their space lattice with that of the other component, or even of a third component in many ternary alloys. The compound then will be stable over a range of compositions even though the space lattice of the definite compound is retained. Such a phase, possessing a range of homogeneity and based upon the space lattice of an intermetallic compound, will be called a secondary or intermediate solid solution.

Instances even are known in which the intermetallic compound is not stable except in the form of a secondary solid solution in which one component is in excess.

The secondary solid solution may or may not melt or decompose at a constant temperature for some one composition, although this would be expected normally.

In general, these secondary solid solutions are also quite hard and brittle, and of little importance commercially by themselves. Under the microscope, they would be similar in appearance to any other single-phase alloy, as illustrated in Fig. 182*b*.

In a constitutional diagram, a field in which a secondary solid solution was the only stable phase would be represented by an area within the diagram, as shown in Fig. 184, although in all such areas this need not be the only stable phase as soon will be seen.

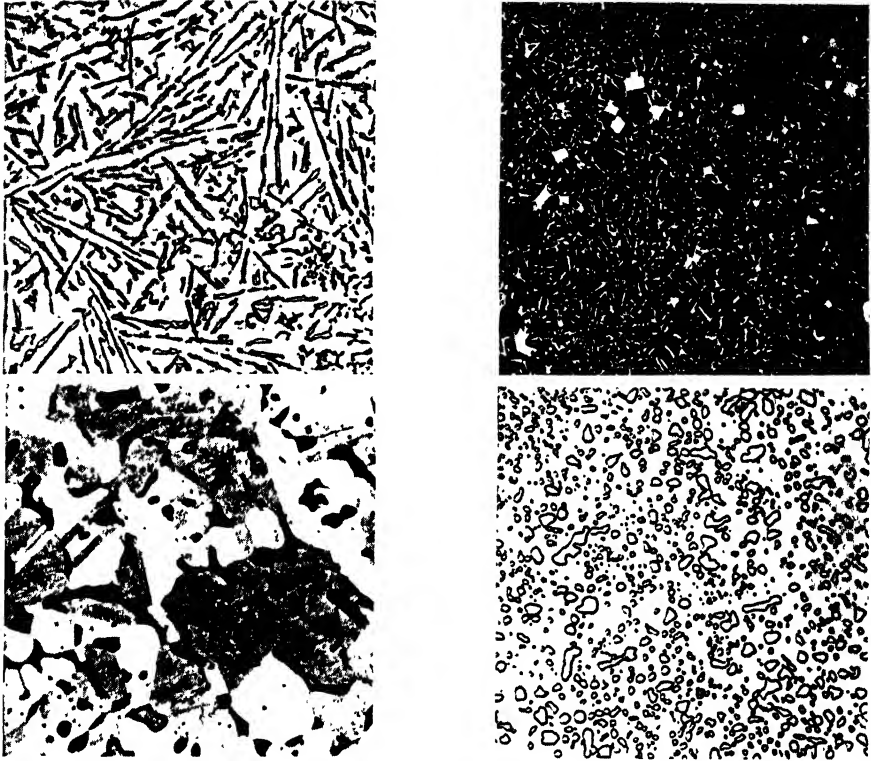


FIGURE 185. Photomicrographs typical of binary alloys which are composed of mechanical mixtures of two phases.

*a. (Upper left)* Two commercially pure components: needles of silicon in an aluminum matrix in an alloy containing 87.5% Al — 2.5% Si. Etched with  $\frac{1}{2}\%$  HF.  $\times 100$ . (Photomicrograph by L. A. Rodecker.)

*b. (Upper right)* Two primary solid solutions: plates of antimony-rich solid solution in a lead-rich solid solution matrix in an alloy containing 87% Pb — 13% Sb. Etched with 5% nital.  $\times 100$ . (Photomicrograph by L. Wysocki.)

*c. (Lower left)* A primary and a secondary solid solution:  $\beta$  secondary solid solution between the grains of twinned  $\alpha$  primary solid solution in a bronze containing 85% Cu — 15% Sn that was quenched from 1100 F (600 C). Etched with Gard's No. 1.  $\times 100$ . (Photomicrograph by C. M. Campbell.)

*d. (Lower right)* A commercially pure metal and an intermetallic compound: spheroidized iron carbide in a matrix of iron in a 1.24% carbon steel. Etched with picral.  $\times 500$ . (Photomicrograph by M. C. Fetzer.)

#### MECHANICAL MIXTURES

Any *two* of the four basic phases also may exist in a binary alloy as a stable mechanical mixture, just as is the case with salt and water, for instance. As salt is added to water, it will dissolve until the limit of solubility is reached. Any salt subsequently added is merely mechanically

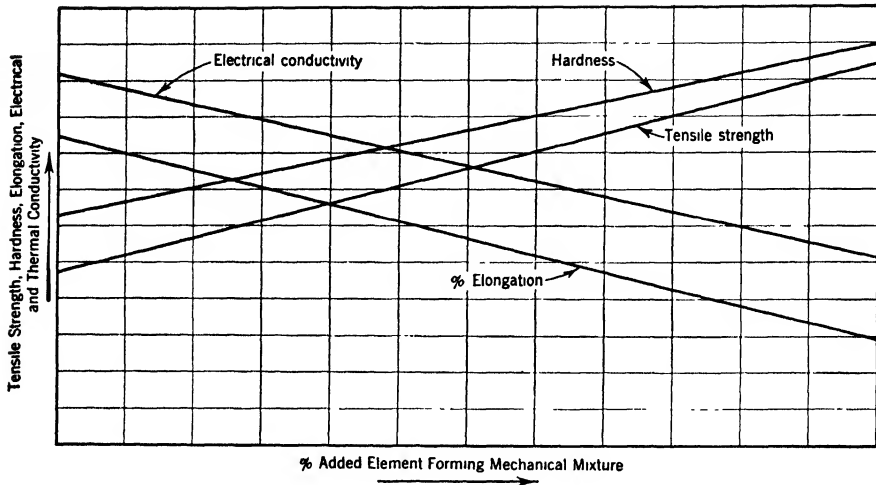


FIGURE 186. Diagrammatic illustration of the general change of properties with composition in alloys which are mechanical mixtures of two phases. Cf. Fig. 477c.

mixed with the saturated water. Other chemicals may form hydrates first, i.e., compounds with the water, which then will be mixed mechanically because their solubility is exceeded.

Likewise with alloys, any two phases may coexist in complete stability provided the temperature is suitable. Thus, two liquid or solid solutions, or any other mixture of any two phases of like or different types, are possible, as illustrated metallographically in Fig. 185 for several solid alloys. Three phases can exist in equilibrium only at certain definite temperatures or compositions, and more than three phases can be present in equilibrium in a binary alloy only under definite and specific conditions of temperature, pressure, and composition. If any of the conditions be changed in these special cases, the excess phase or phases must disappear and the number decrease to a maximum of two.

The properties of alloys which are mechanical mixtures of two phases generally are related nearly linearly to those of the two constituents, as illustrated schematically in Fig. 186. The minor constituent, of course, must be distributed with reasonable uniformity and, preferably, should approach a globular form.

### ✓ *Typical Binary Alloy Systems*

#### ALLOYS EXHIBITING COMPLETE SOLUBILITY IN BOTH THE SOLID AND LIQUID STATES

The nature of and methods for securing the heating and cooling curves of a pure metal already have been discussed in Chap. II. If similar methods

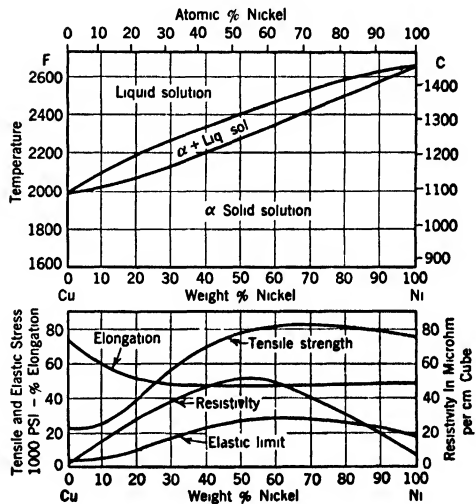
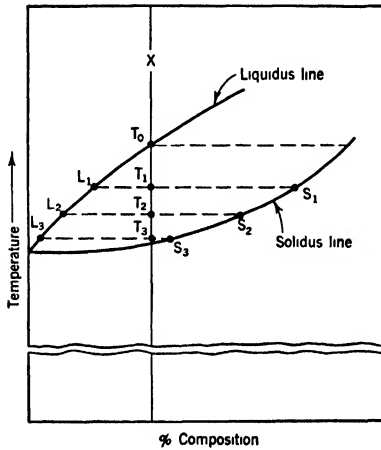
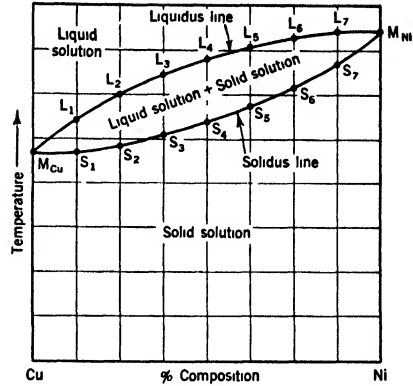
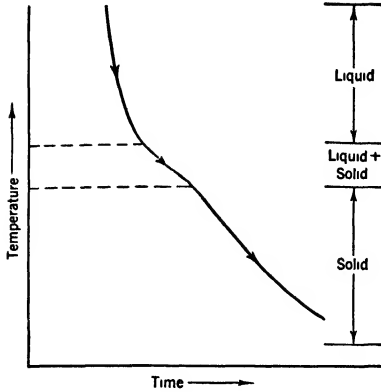


FIGURE 187. (Top left) Idealized cooling curve typical of a solid solution alloy.

FIGURE 188a. (Top right) Binary constitutional diagram in which complete liquid and complete solid solubility occurs, as plotted from cooling curve data.

b. (Middle right) Constitutional diagram typical of binary alloys in which complete liquid and solid solubility occur: the alloys of copper and nickel. (After M. Hansen.)  
 c. (Bottom right) Change of properties with composition in the alloys of copper and nickel. (After A. Krupkowski.)

FIGURE 189. (Bottom left) Schematic representation of the changes in composition of the liquid and solid solution phases during the solidification under equilibrium conditions of the alloy X.

are used to examine the thermal changes, on heating and cooling, of the alloys of two metals, such as copper and nickel, for example, it will be found that the curves differ considerably from those of either pure metal. For simplicity, further discussion will be confined to cooling curves, because heating curves will be essentially the reverse of the cooling curve with probably some temperature displacement.

The typical cooling curve shown in Fig. 187 consists of three branches: (a) the liquid solution cools uniformly, exactly as in the case of a pure liquid metal; (b) there is a change in slope to another uniform curve within the limits of which both a solid and a liquid phase coexist in equilibrium; (c) there is a second change in slope, below which the solid metal cools uniformly. Examination of a series of alloys of copper and nickel in varying proportions would disclose that all of them gave similar curves, differing only in the temperatures at which the changes in slope occur. Microscopic examination of the completely solidified alloys, cooled slowly enough to establish essential equilibrium, would disclose that in every case they would be composed of only one kind of uniform crystal. This indicates that there is only one solid phase present, and since every alloy in the series is composed of similar crystals, this phase must have a variable composition, and therefore must be a solid solution. Furthermore, since the change from either pure metal to the solid solution is continuous it must be a primary solid solution.

If a temperature-composition diagram now is made by plotting the freezing points of the pure metals, copper and nickel, and the two transformation points of each of their alloys that was studied, the diagram shown in Fig. 188a will result. Above the upper line, called the *liquidus line*, only one liquid solution exists, whereas below the lower line, called the *solidus line*, only one solid, in this case a solid solution, exists.

These alloys, therefore, are completely soluble in *both* the *liquid* and *solid states*, and are composed of mixtures of solid and liquid solutions in the lenticular region on the diagram during solidification. The property changes shown below the diagram are, in general, in agreement with those already discussed for the solid-solution type of alloy phase.

The fields on the diagram above the liquidus and below the solidus in which only one phase is stable, i.e., exists under equilibrium conditions, will be termed *single-phase fields*. The area on the diagram separating these two single-phase fields in which two phases, one liquid and one solid in the diagram shown, co-exist in equilibrium will be termed a *two-phase field*.

#### CHANGES OCCURRING DURING THE SOLIDIFICATION OF SOLID SOLUTION ALLOYS

It is interesting to consider more fully the changes occurring in one alloy of this type as it solidifies. This information can be secured by first establishing approximate equilibrium, e.g., by holding the temperature constant for a sufficiently long time for intermetallic diffusion to make each of the

phases essentially homogeneous, and then separating the liquid and solid completely, weighing and analyzing both. The results of several of these analyses can be followed better by reference to Fig. 189.

At and above a temperature  $T_0$ , the alloy is entirely a liquid solution. Data secured at temperature  $T_1$ , however, would show that the composition of the liquid in equilibrium with solid is  $L_1$ , whereas that of the solid is  $S_1$ .  $L_1$  and  $S_1$  will be found to be the intersections of the temperature isotherm,  $T_1$ , with the liquidus and solidus curves respectively. Repeating this test at other temperatures,  $T_2$  and  $T_3$ , would verify this information. This demonstrates the known fact that the *composition of the liquid and the solid in equilibrium in any two-phase field at any temperature can be secured by drawing an isotherm at that temperature, and determining its intercepts with the liquidus and solidus lines, or, more generally, with the boundary lines at either limit of that two-phase field.* This statement will be known as the *composition rule*. It can be used to determine the stable compositions in any two-phase field for any constant temperature.

It can be understood readily, therefore, that even though solid-solution type alloys will form homogeneous liquid solutions before solidification and homogeneous solid solutions after complete equilibrium solidification, both the liquid and the solid phases will change markedly during the course of solidification.

During this solidification stage in particular, the process of diffusion is extremely important because the first crystals that separate from the liquid are always richer in the higher melting component, nickel in the example selected, whereas the last liquid to freeze is always richer in the lower melting component, copper in this example. As long as the liquid continues to solidify or freeze slowly under conditions of equilibrium, new solid crystals will continue to form and grow constantly in size. In addition, each crystal must change its composition continuously as the temperature falls, and approach the equilibrium composition as indicated by points on the solidus line. Simultaneously, the liquid must vary in composition continuously as indicated by points along the liquidus line. This continuous change in composition is a process that proceeds by diffusion, and requires an appreciable time even at the relatively high temperatures employed.

The apparent anomaly of both liquid and solid solutions becoming richer in the lower melting component at the same time is, of course, only possible because the relative amounts of the two vary so markedly during solidification. This can be shown best by drawing any diagram of this type on graph paper, and then following quantitatively the changes occurring during solidification by using the *lever rule*.

## THE LEVER RULE

The *relative weights* of the two phases in equilibrium also can be determined in a simple manner from the constitutional diagram. For any constant composition, it should be apparent that, if the temperature corresponds to that of the liquidus, the alloy will be completely liquid (100% liquid), whereas if it corresponds to that of the solidus, it will be completely solid (100% solid). The amount of either phase (the sum of the two, obviously, always must be 100%) existing at temperatures in between these two points, such as temperature  $T_2$  in Fig. 189, for example, can be determined by drawing a line *equal in length* to the distance between the liquidus and the solidus at the desired temperature, and marking on it the average composition of the alloy being studied. This procedure is indicated in Fig. 190. If this line then is divided into 100 parts starting with zero at the liquidus end, as indicated, the intercept will read off the weight per cent of the total that is solid. If, on the other hand, it is divided into 100 parts starting with zero at the solidus end, the intercept will indicate the weight per cent of the total that is liquid. However, identical results can be secured without going to all this trouble merely by using the simple relationships:

$$\frac{\text{Percentage liquid}}{100\%} = \frac{\text{distance } x \text{ } s}{\text{distance } l \text{ } s}$$

$$\frac{\text{Percentage solid}}{100\%} = \frac{\text{distance } l \text{ } x}{\text{distance } l \text{ } s}$$

This simple rule is known as the lever rule because of its similarity in principle to the simple lever, viz., the greater percentage (weight) is on the opposite side of the composition studied,  $x$  (the fulcrum), from the longer lever arm.

It must be emphasized specifically that *the lever rule tells nothing about the compositions or nature of the phases involved*, and only deals with their *relative* amounts. Their compositions must be secured by using the composition rule already described, and their nature can be reasoned out quite simply.

## CORING RESULTING FROM NONEQUILIBRIUM SOLIDIFICATION

Since cooling rates under equilibrium conditions must be infinitely slow and under conditions even closely approximating equilibrium still must be extremely slow, they are attained commercially, seldom, if ever. Industrial practice, rather, usually is to cool as rapidly as is compatible with soundness in order to speed up production. This means that the alloy solidifies before the compositions of the crystals can be equalized

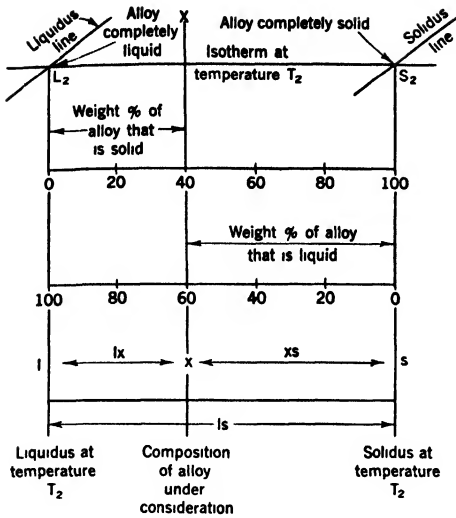


FIGURE 190. (Left) Diagrammatic representation of various methods of applying the lever rule to a two-phase alloy in order to determine the relative amounts of the two phases that will be in equilibrium at any temperature,  $T_2$ .

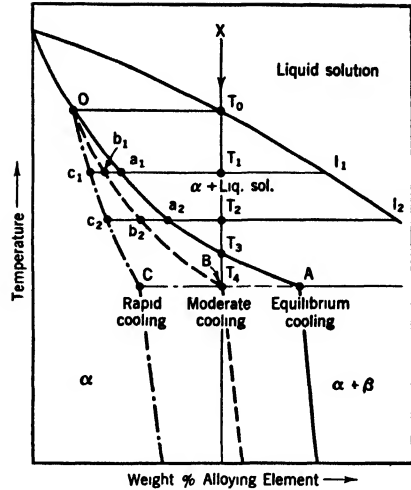


FIGURE 191. (Right) Effect of nonequilibrium solidification on the apparent position of the solidus line as indicated on a constitutional diagram.

The alloy  $X$  begins to solidify at temperature  $T_0$  by the formation of crystals of composition  $O$ . As the temperature falls to  $T_1$  the crystals should grow and change by diffusion to composition  $a_1$ . However, because the cooling rate is too rapid to permit complete diffusion, they actually will have an *average* composition, such as  $b_1$  or  $c_1$ , which is richer in the dominant metal than  $a_1$ . As the temperature continues to fall the lack of sufficient time for complete diffusion will cause the *average* composition of the solid crystals to follow an *apparent solidus line*, such as  $OB$  or  $OC$  instead of the equilibrium solidus line  $OA$ . Thus, even though, during equilibrium solidification, the alloy should be a homogeneous solid solution at temperature  $T_3$ , during more rapid, nonequilibrium, cooling solidification might not be complete until temperature  $T_4$  is reached and alloy  $X$  even might solidify as a two-phase instead of a single-phase alloy.

through diffusion; and hence that each crystal will be composed of successive layers of alloy, each differing from the others in composition. The net result is a definite deviation from the results predicted by the equilibrium diagram, sometimes leading to the formation of compounds when none should exist for that composition under conditions of even approximate equilibrium. Fig. 191 illustrates such a condition diagrammatically. The apparent solidus line is shifted farther toward the left end of the diagram as the rate of cooling is increased.

When the alloy,  $X$ , which crosses the liquidus at temperature  $T_0$ , begins to solidify, solid crystals of composition  $O$  will begin to form. As the temperature falls to  $T_1$  these crystals should grow in size and change by



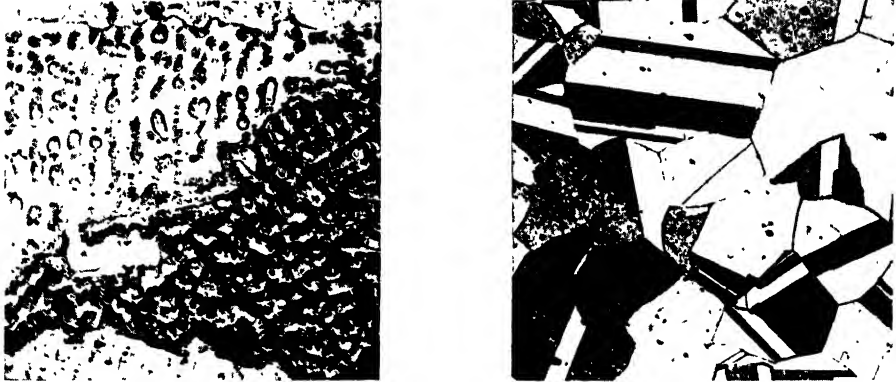


FIGURE 192. Metallographic structure of cartridge brass, a solid solution alloy containing 70% Cu — 30% Zn. Etched with  $\text{NH}_4\text{OH} + \text{H}_2\text{O}_2$ .  $\times 75$ .

*a.* (Left) As cast, illustrating the appearance of a typical cored dendritic structure. (Photomicrograph by T. S. Luerssen.)

*b.* (Right) After homogenization by cold-working and annealing, illustrating the typical twinned structure of a copper-base solid solution. (Photomicrograph by C. E. Thompson.)

diffusion to the equilibrium composition  $a_1$  (the liquid meanwhile acquiring the composition  $l_1$ ). However, if insufficient time is given for complete diffusion to occur, the crystal will not become homogenized and instead will have an average composition intermediate between  $O$  and  $a_1$ , such as  $b_1$  or  $c_1$  for example. The solidus for cooling under nonequilibrium conditions thus will appear to follow lines such as  $OB$  or  $OC$  instead of  $OA$ , and the alloy will become completely solid at a somewhat lower temperature than normally would be expected. If, however, the temperature should be held constant for a long enough time during the cooling cycle, diffusion will cause the composition to become uniform and the real solidus will be approached as equilibrium is attained.

Thus, for *nonequilibrium solidification*, crystals of an alloy not only will tend to be built of “cores” of varying thicknesses and compositions, but also may occur in conjunction with particles of a second phase which under equilibrium conditions would be completely soluble.

This occurrence of crystals containing layers of different composition is known as *coring*, and can be detected metallographically because of the different etching characteristics of the various layers (Fig. 192*a*). Before working many such alloys to any extent, they must be homogenized carefully to structures similar to that shown in Fig. 192*b*. Otherwise, the strain gradients accompanying the concentration gradients will be apt to cause cracking even for deformations lower than those customarily used.

Methods for removing this coring and homogenizing the alloys will be

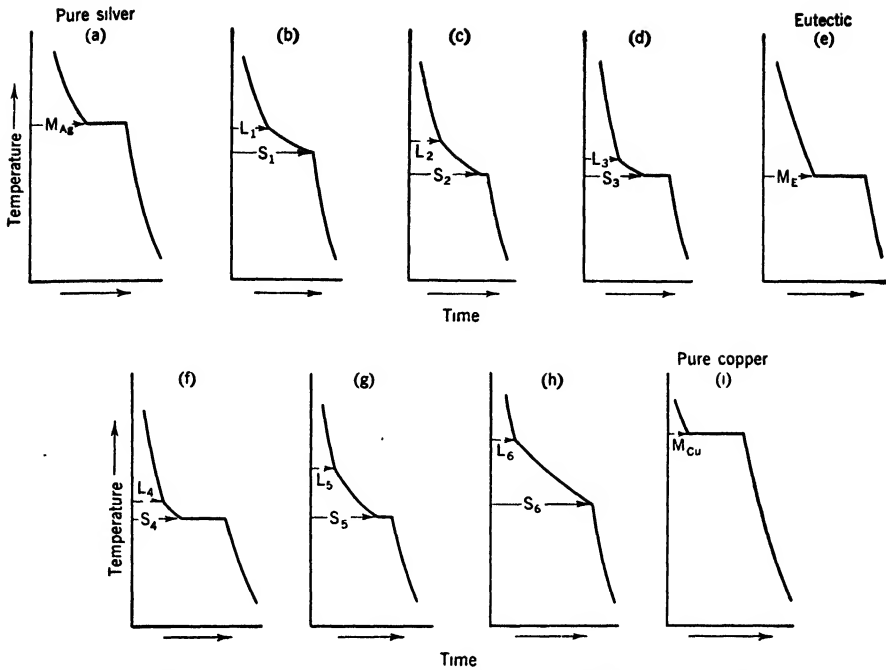


FIGURE 193. Idealized cooling curves for silver and copper and a series of seven of their alloys.

discussed later but, essentially, they all are based upon combinations of recrystallization, and/or increased diffusion.

#### ALLOYS EXHIBITING PARTIAL SOLID SOLUBILITY

If silver is selected as a metal to be alloyed with copper instead of nickel, a somewhat different set of conditions will obtain, as indicated in Figs. 193 and 194. The cooling curves of the pure metals, (a) for silver and (i) for copper, will be, of course, similar to those previously found. It will be noted also that the cooling curves of alloys containing only small amounts of copper, (b), as well as those containing only small amounts of silver, (h), will be similar to those of the copper-nickel system. This indicates, of course, that there is some tendency for silver to dissolve copper, and for copper to dissolve silver in the solid state. However, as the concentrations of either element are increased, the cooling curves will assume the shape shown in (c) through (g). A portion of the alloy will solidify over a range of temperature, whereas the remainder, indicated by the flat portion of the curves, always will solidify at a constant temperature. In addition, it will be noted that the flat portion of the curve increases in length, indicating a longer time at this constant temperature, as the amount of silver in copper or copper in silver is increased. Finally, for the alloy, 71.5% Ag-

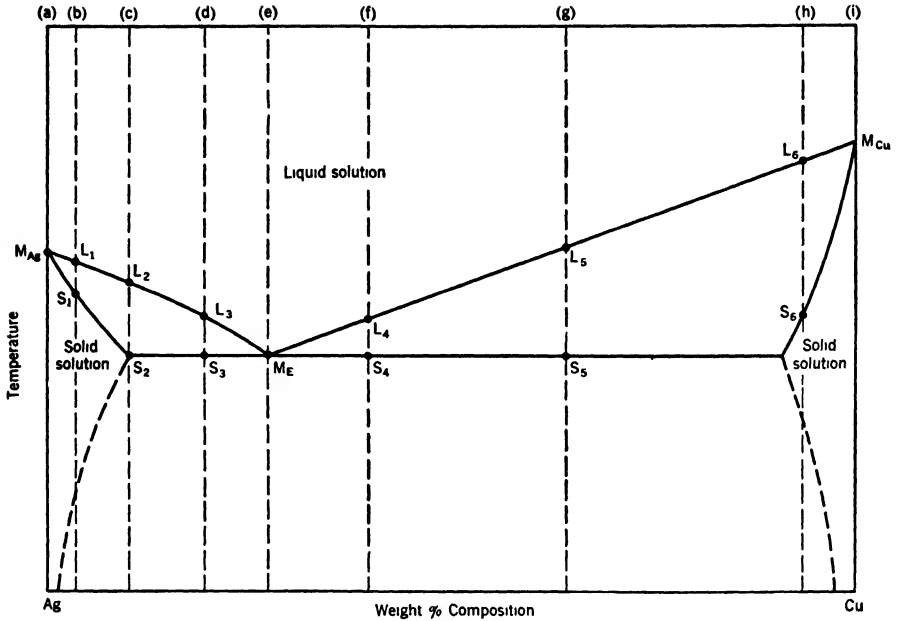


FIGURE 194. A binary constitutional diagram in which complete liquid solubility and partial solid solubility occurs, as plotted from the cooling curve data of Fig. 193.

28.5% Cu (by weight), the shape of the curve, (e), will be exactly the same as that of a pure metal or of an intermetallic compound. Solidification of the entire alloy occurs at a constant temperature. This temperature, 1435 F (780 C), will be, however, much lower than the freezing point of either copper or silver.

*Is this composition indicative of an intermetallic compound?* It obviously cannot be a pure metal since it contains both copper and silver. It is probably not a solid solution because it melts at a constant temperature. Its fixed composition and definite, although low, melting point clearly would suggest the other alternative. Were it a compound, it would be a single phase and, therefore, would be composed of homogeneous crystals. Metallographic examination of this alloy, using a high magnification to resolve its structure, would show definitely that it is composed of two distinct phases, as can be seen in Fig. 195a, and establishes in this manner that it cannot be a compound. At low power, however, where the two phases cannot be separated because of low resolution, the structure may appear to be uniform. Because of this fact, it frequently is considered to be a separate constituent, termed an *eutectic*.

#### THE EUTECTIC

An eutectic may be defined as the lowest transforming (i.e., in this case, freezing) liquid solution.

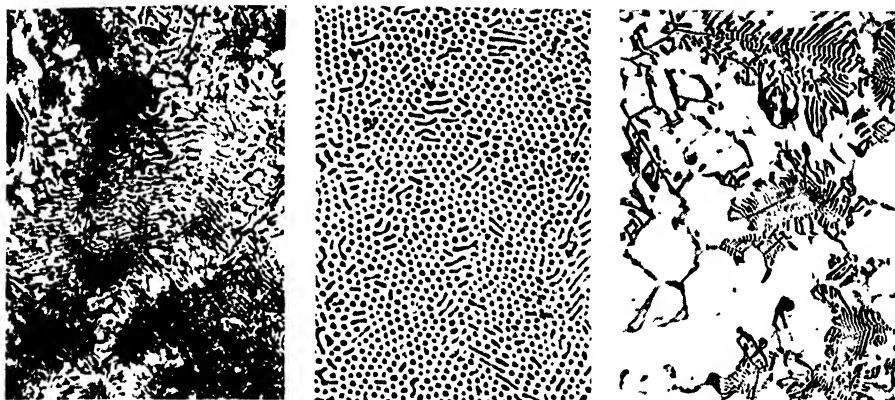


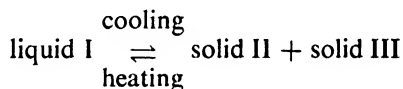
FIGURE 195. Photomicrographs illustrating the three common types of eutectic structures.

a. (Left) Lamellar: the alloy 71.5% Ag-28.5% Cu. Etched with  $\text{NH}_4\text{OH} + \text{H}_2\text{O}_2$ .  $\times 500$ . (Photomicrograph by L. Litchfield.)

b. (Center) Granular: the ledeburite eutectic of iron and iron carbide, 95.75% Fe-4.25% C, produced by melting commercially pure ingot iron under graphite. Etched with nital.  $\times 500$ . (Photomicrograph by M. C. Fetzer.)

c. (Right) Chinese script: eutectic (dark) in an aluminum casting alloy. Etched with  $\frac{1}{2}\%$  HF.  $\times 100$ . Other constituents also can be seen as the alloy is complex. (Photomicrograph by O. G. Morgan.)

It sometimes is understood more clearly if the reaction occurring *at constant temperature* is expressed by the equation:



The structure of the eutectic in a binary system consists of a finely dispersed mixture of two phases. However, eutectics also may occur in ternary or more complex systems, and may be made up of a larger number of phases under certain conditions.

Three types of eutectic structures commonly are found: (1) the *lamellar* or layerlike type of eutectic, in which the structure is composed essentially of alternate layers of the phases involved; (2) the *granular* eutectic, in which the structure is composed of more or less regular fine particles of one phase dispersed in the other; (3) the so-called *Chinese script* type of structure, which is characteristic of certain alloys. Typical examples of these three types are shown in Fig. 195.

#### CONSTITUTIONAL DIAGRAM FOR ALLOYS EXHIBITING PARTIAL SOLID SOLUBILITY

If the thermal data which have been secured for the system silver-copper are plotted on the usual temperature-composition diagram the solid lines

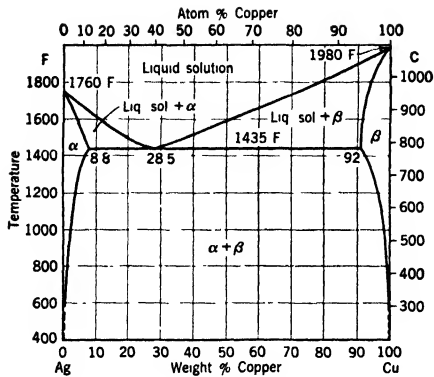


FIGURE 196. Constitutional diagram typical of binary alloys in which complete liquid and partial solid solubility occur: the alloys of silver and copper. (After M. Hansen.)

indicated in Fig. 194 will be secured. The dashed lines, which indicate the limits of solid solubility and are required to complete the diagram, usually must be determined by other methods since, in general, the heat effects which will be given by them are too slight to be detected by the simpler methods of thermal analysis. By comparison with the copper-nickel diagram, it should be clear that in the silver-copper system (Fig. 196) there are three single-phase fields:

1. The *liquid solution* of silver and copper, existing for all compositions at temperatures above the

uppermost, i.e., liquidus, line.

2. A *primary solid solution* rich in silver, here designated  $\alpha$ , which is stable for compositions and temperatures falling in the left-hand area.
3. A *primary solid solution* rich in copper, here designated  $\beta$ , which is stable for compositions and temperatures falling in the right-hand area.

In each of the other three fields, mechanical mixtures of two of these phases will be stable, the compositions of each phase being determined by the intersections of a given isotherm with the proper boundary of the two-phase field. Knowing the composition and temperature, the relative amounts of the two phases can be computed by means of the lever rule.

#### RETROGRADE SOLUBILITY

Particularly to be noted is the slope of the lines, sometimes called the *solvus* lines, which indicate the limits of solid solubility. The maximum solubility of copper in silver (8.8% copper) and of silver in copper (8.0% silver) occurs at the eutectic temperature; and, as the temperature falls, the solubilities decrease steadily to the room-temperature values of less than 0.3% copper (in silver), and somewhat less silver in copper. Consequently, if an alloy falling within either of these ranges, such as the *sterling silver* composition (92.5% Ag-7.5% Cu) indicated in Fig. 197, is heated above the solid solubility line, it will be a completely homogeneous solid solution with all the copper dissolved atomically in the silver. If this alloy then is cooled slowly back to room temperature, it no longer can remain a

stable solid solution as the solubility of copper in silver will decrease. This excess copper will separate out or precipitate, not as a pure metal but as a solid solution, rich in copper and containing as much of the silver as it can hold in solid solution, i.e., its composition at room temperature under equilibrium conditions is given by the intersection of the room-temperature isotherm with the solid solubility limit of silver in copper. This precipitate, depending on the alloy, may occur either (a) at the grain boundaries, or (b) scattered uniformly throughout the grains. These possibilities are illustrated diagrammatically in Fig. 245 and metallographically in Fig. 198.<sup>10</sup>

#### OCCURRENCE OF THE EUTECTIC CONSTITUENT

Two other facts concerning the occurrence of the eutectic constituent must be noted. First, in order for the eutectic to appear at all in the solidified alloy, some liquid of eutectic composition must solidify, i.e., the composition of the alloy must lie between the limits of the eutectic horizontal. If this condition is not satisfied, any second phase that appears will be present as a dispersed solid solution rather than as part of the eutectic. Second, since the solid solubilities of both solid solutions generally will decrease with decreasing temperature, the eutectic constituent in these alloys is fixed in average composition only; and the distribution, as well as the composition of the two phases concerned under equilibrium conditions, will vary with the temperature. Thus it is possible, although rather difficult to observe because of the fine degree of dispersion, to have a binary alloy of this type consist of three constituents, e.g., primary solid solution rich in silver, primary solid solution rich in copper which has precipitated within the silver-rich solution during cooling, and eutectic, yet there will be only two phases present, namely, the two primary solid solutions. Actually, therefore, *the equilibrium diagram alone gives information only about the number and nature of the phases existing under equilibrium conditions. It says nothing directly about the state of aggregation or method of dispersion of these phases.* This information can be inferred to some extent from the diagrams, but only after the student has acquired a certain amount of experience and familiarity with them. This limitation of the constitutional diagram is significant because the relative amounts and degrees of dispersion of the various phases are the specific points which are of the greatest value in determining the probable characteristics of the alloy and therefore its possible engineering uses.

<sup>10</sup> For a further discussion, see R. F. Mehl and L. K. Jetter in *Age Hardening of Metals*: Amer. Soc. for Metals, Cleveland, Ohio, 1940.

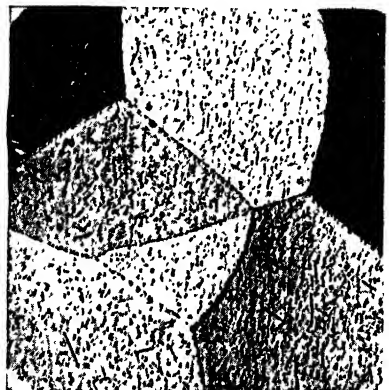
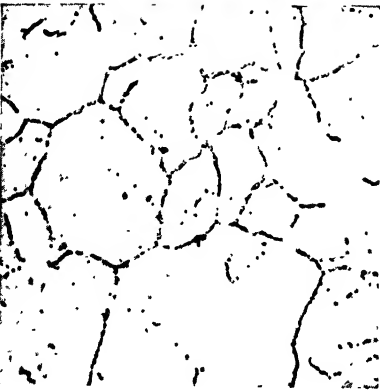
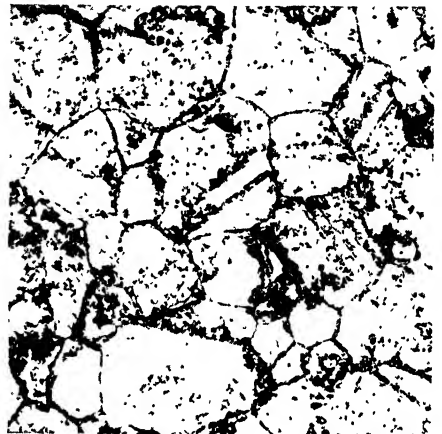
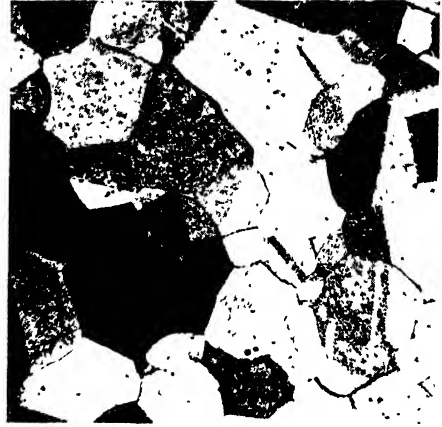
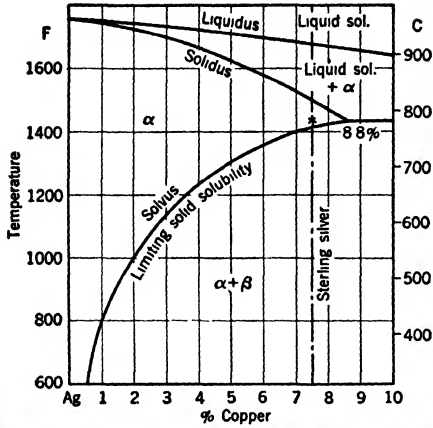


FIGURE 197. (Top left) Silver-rich portion of silver-copper constitutional diagram plotted on an enlarged composition scale in order to illustrate the structural changes occurring within the solid alloys on cooling.

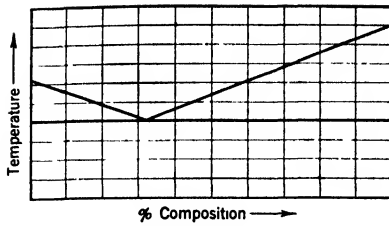


FIGURE 199. (Left) An idealized simple eutectic diagram, a limiting case of alloys in which solid solubility is only partial.

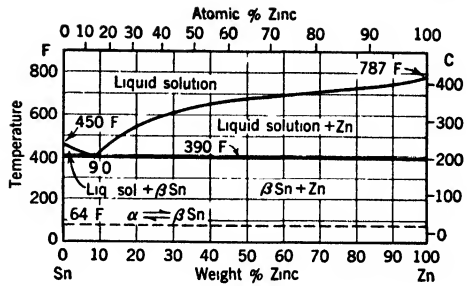


FIGURE 200. (Right) Typical simple eutectic constitutional diagram: the alloys of tin and zinc. (After M. Hansen.)

### THE SIMPLE EUTECTIC DIAGRAM

As the mutual solubilities of the two metals become smaller and smaller, the width of the areas concerned on the equilibrium diagram also will decrease. It should be clear, therefore, that the limiting case of the partial solid solubility diagram will be that shown in Fig. 199, in which the width of the respective areas is less than the scale of the diagram can resolve, and each area, therefore, is represented by a line. This is the so-called simple eutectic diagram and is interpreted exactly the same as other diagrams showing partial solid solubility, except that since the single phase regions are now lines, they are, by definition, commercially pure metals instead of primary solid solutions. Although this ideal case never has been found, the tin-zinc system (Fig. 200) is probably a close approximation.

FIGURE 198. Metallographic structures illustrating typical examples of precipitation from a supersaturated solid solution.

- (Top right) Sterling silver (92.5% Ag-7.5% Cu). Quenched from  $\alpha$  solid solution field. Etched with  $\text{NH}_4\text{OH} + \text{H}_2\text{O}_2$ .  $\times 300$ . Reduced about one half in reproduction.
- (Middle left) Sterling silver (92.5% Ag-7.5% Cu). Slowly cooled from  $\alpha$  solid solution field, showing copper-rich solid solution precipitated at grain boundaries. Etched with  $\text{NH}_4\text{OH} + \text{H}_2\text{O}_2$ .  $\times 300$ . Reduced about one half in reproduction.
- (Middle right) Sterling silver (92.5% Ag-7.5% Cu). Quenched, and aged 1 hr at 550 F (290 C), showing copper-rich solid solution precipitated both at grain boundaries and within the grains, particularly at the edges of annealing twin bands. Etched with  $\text{NH}_4\text{OH} + \text{H}_2\text{O}_2$ .  $\times 300$ . Reduced about one half in reproduction. (Photomicrographs *a*, *b*, and *c* by L. Litchfield.)
- (Bottom left) An 18:8 type stainless steel. Quenched from 1950 F (1065 C) and heated 15 min at 1720 F (940 C), just below the solvus temperature, showing coarse precipitate occurring predominantly at the grain boundaries. Etched electrolytically with 2½% oxalic acid.  $\times 750$ .
- (Bottom right) The 96% Al-4% Cu alloy, showing fine precipitate predominantly within the grains and aligned somewhat on a geometrical pattern, but with some grain boundary precipitate also. Etched with Keller's reagent.  $\times 100$ . (Photomicrograph courtesy Aluminum Research Laboratories.)



## THE 1:2:1 RULE

A study of the three simple diagrams already discussed will disclose two very interesting facts which are of great assistance in interpreting and understanding more complex binary diagrams. First, there is generally a considerable, if not a complete, solubility of the two liquid metals in each other. This liquid solution constitutes a single phase. Second, by proceeding across the diagram *at a constant temperature*, the sequence of the *number of phases* which are stable in the successive fields is always 1:2:1, etc., each colon indicating a line on the diagram and each number indicating the number of phases that is stable in each corresponding field on the diagram.

The application of these two observations will eliminate any uncertainty as to whether, in a given area adjacent to a pure metal or to a compound on a constitutional diagram, a simple solid solution or a mechanical mixture of two phases is stable. By starting with a single (liquid) phase in the field above the liquidus line and proceeding horizontally (at a constant temperature) back and forth across the diagram, every field can be labeled immediately as a single- or a two-phase field. As a check, and in order to detect single-phase fields of zero width, i.e., lines designating definite compositions, it is advisable to work from both directions instead of from one only. This method has been applied to the three simple diagrams in Fig. 201.

Once the diagram has been labeled in this manner, it is only necessary to determine, by deduction, the nature of the phases stable in the single-phase regions. In the two-phase regions, mechanical mixtures of the single phases stable in the fields on either side occur.

If the single-phase field is an area, it must be a solid solution. If it is a line, it can be either a pure metal or an intermetallic compound. If the area or line occurs at the end or terminus of the complete diagram, i.e., adjacent to either of the pure metals, it then indicates a primary solid solution if it is an area, or a commercially pure metal if it is a line. On the other hand, if the area or line is separated from the pure components by one or more two-phase fields, then it must indicate a secondary solid solution (area) or an intermetallic compound (line). Since the general characteristics of all of these phases should be known by now, and since the relative amounts of each of them existing in a given alloy under conditions of equilibrium can be computed readily either from the lever rule or from the nature of the diagram, a satisfactory qualitative or semiquantitative estimate of the properties of the alloys *under equilibrium conditions* can be made.

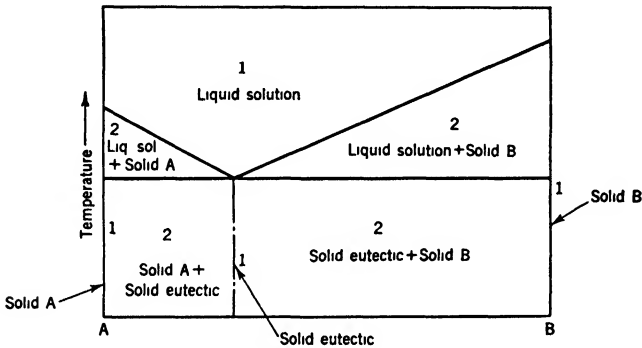
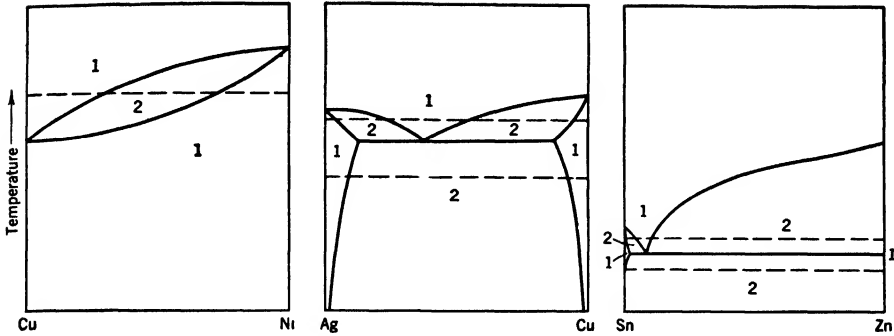


FIGURE 201. (Upper) Application of 1:2:1 rule to the three simple types of binary constitutional diagrams.

FIGURE 202. (Lower) Application of 1:2:1 rule to the simple eutectic diagram. The eutectic is considered to be a separate constituent, and is treated as a phase purely as a matter of convenience.

If conditions other than equilibrium exist, the problem becomes very much more complicated. Sometimes the properties of the alloys can be deduced fairly well from the nature of the diagram, but more frequently than not, this leads to very misleading results. In any case, it should be applied with extreme caution.

CONSTITUENTS

Much of the study of metals is carried out with the aid of the microscope. This is the science of *metallography*, and the separate and distinct types of crystals that can be recognized under the microscope are known as the metallographic constituents. These constituents must be unique, both as regards their appearance and their properties. In fact, it is the size, shape, and arrangement of the constituents with respect to one another that determines the specific properties of a metallic aggregate.

It will be obvious at once that any of the phases of a system, either solid or liquid, also may appear as constituents with the restriction previously stated that, in a binary alloy, no more than two phases can coexist in equilibrium except under very special conditions, e.g., at certain constant compositions and temperatures such as the eutectic point.

In addition to the phases, however, certain mechanical mixtures of two phases occasionally occur which, under conditions of equilibrium, will have definite compositions, transformation temperatures, and properties. It is often *convenient* to consider these specific mixtures as constituents also. Usually, but not necessarily, these constituents are apparently uniform at low magnification, although at high magnification they always can be resolved into their separate phases. The eutectic is an example of such a constituent, particularly in a simple eutectic type of diagram.

In the application of the 1:2:1 rule to the *simple eutectic system*, these constituents can be treated, if desired, exactly as if they were phases, as indicated in Fig. 202. The two-phase area under the eutectic line thus can either be considered as a mechanical mixture of two commercially pure metals, *A* and *B*, or else subdivided into three regions, in which will occur, respectively, metal *A* + eutectic, eutectic, and eutectic + metal *B*, as shown. This method of analysis, when any solid solubility occurs as in the silver-copper system (Fig. 196) is complicated by the two facts which already have been mentioned: first, that both the relative amounts of the two phases comprising the eutectic and their compositions will vary with the temperature, depending on the slopes of the solid solubility lines; and second, that eutectic only can be found in the solid alloy if liquid of eutectic composition solidifies. These facts, of course, make the quantitative use of constituents troublesome unless little or no solid solubility exists, or unless the solid solubility does not change appreciably with temperature. If the solid solubilities are essentially constant with temperature, as with certain ranges of compositions in the iron-carbon alloys to be discussed later, the constituents can be treated as though they were separate phases without any difficulty.

#### DIAGRAMS IN WHICH ONE OR MORE INTERMETALLIC COMPOUNDS EXIST

In Fig. 203 is shown the magnesium-lead diagram as an illustration of a system in which both metals are partially soluble in each other and, in addition, form an intermetallic compound,  $Mg_2Pb$ . For purposes of interpretation, a diagram such as this one may be considered in either of the two ways shown. According to the first method, it is treated as though it

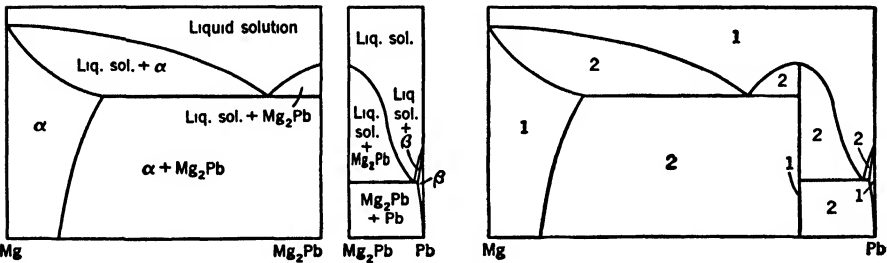
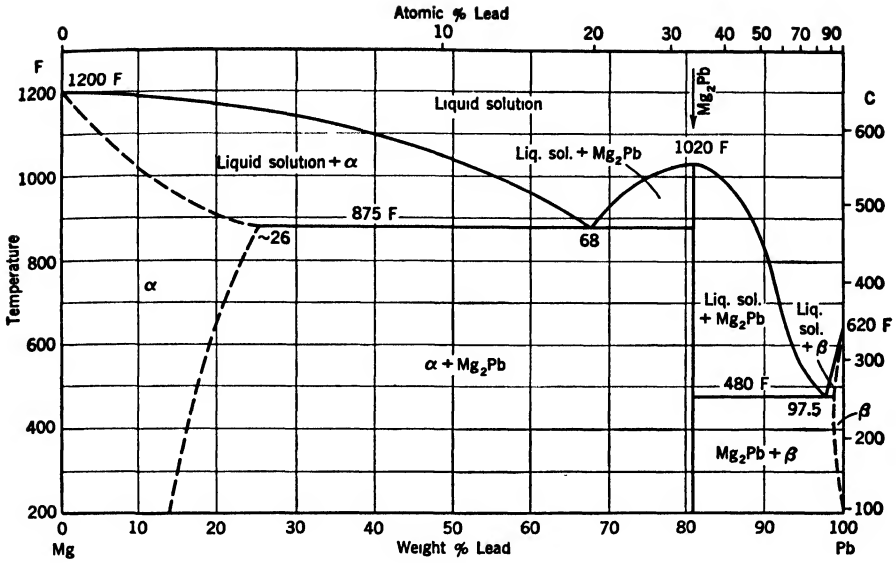


FIGURE 203a. (Upper) Constitutional diagram typical of binary alloys in which one intermetallic compound is formed: the alloys of magnesium and lead. (After M. Hansen.) b. (Lower) Alternate methods for interpreting diagram, (left) by division into two simpler diagrams, and (right) by use of the 1:2:1 rule.

were two diagrams placed side by side, one between magnesium and the compound  $Mg_2Pb$ , and the second between the compound  $Mg_2Pb$  and lead. It will be clear at once that each of these diagrams is merely an eutectic diagram exhibiting partial solid solubility such as has been discussed already. The alternate method considers the diagram as a whole, and to it applies the 1:2:1 rule in order to assist in its interpretation. Which of these methods, if either, is selected by the student is largely a matter of personal choice.

In Fig. 204, the system copper-magnesium is shown. This system has four single-phase regions:

1. A primary solid solution,  $\alpha$ , of magnesium in copper
2. The intermetallic compound,  $Cu_2Mg$

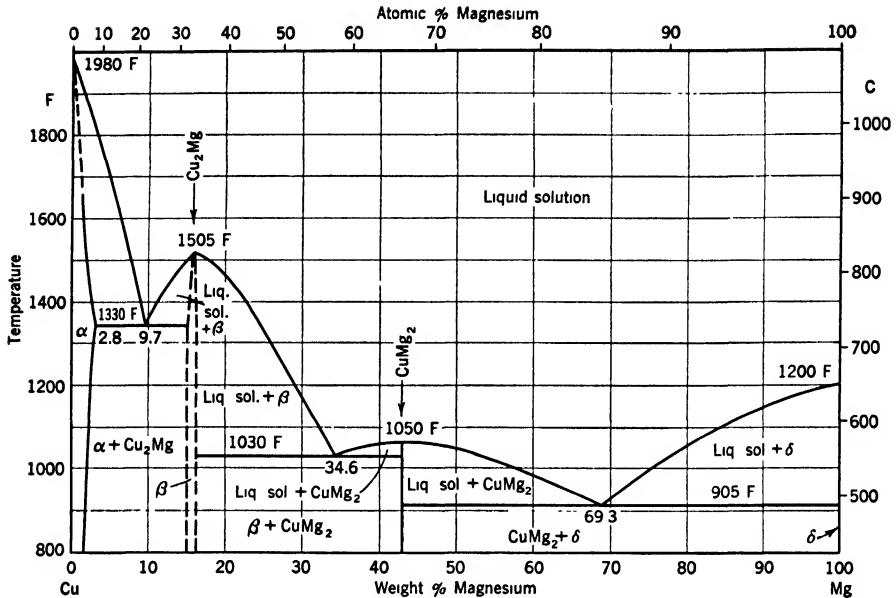


FIGURE 204. Constitutional diagram typical of binary alloys in which two intermetallic compounds are formed: the alloys of copper and magnesium. (After M. Hansen.)

3. The intermetallic compound,  $\text{CuMg}_2$
4. Commercially pure magnesium (containing a maximum of 0.4–0.5% copper in solid solution).

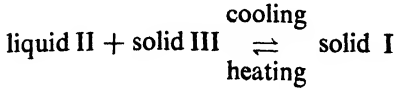
#### THE PERITECTIC REACTION

The system antimony-tin (Fig. 205) has two secondary solid solutions and two primary solid solutions. Both secondary solid solutions melt incongruently at constant temperatures, i.e., each decomposes to a mixture of liquid and solid solutions at a definite temperature rather than melting completely like a normal compound, or over a range of temperatures, like a normal solid solution. In this system there are four solid phases:

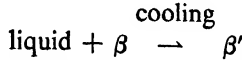
1. A primary solid solution,  $\alpha$ , of tin in antimony
2. Two secondary solid solutions,  $\beta$  and  $\beta'$ , both apparently based on different polymorphic forms of the compound  $\text{SbSn}$
3. A solid solution,  $\gamma$ , of antimony in tin

The incongruent melting of a compound or, as occurs here, a solid solution at a constant temperature takes place by what is known as a *peritectic reaction*. This type of reaction is exactly the reverse of the eutectic reaction, the homogeneous-solution phase occurring below rather than

above the constant reaction temperature. It may be expressed, therefore, by the general equation:



Consider for example, the cooling under equilibrium conditions of an alloy containing equal parts of antimony and tin. Solidification begins by the formation of crystals of the  $\beta$  solid solution containing initially about 65% Sb–35% Sn. This continues, with changing composition of the solid and liquid phases, until the temperature falls to 615 F (325 C). Here the reaction



begins, and continues at this constant temperature, until complete transformation and solidification have occurred. The alloy at room temperature will then consist entirely of uniform and homogeneous crystals of the  $\beta'$  secondary solid solution.

It must be noted that the direct reaction between the liquid solution and solid  $\beta$  can take place only at their surface of contact. Once the first protective coating of  $\beta'$  is formed the rate of further reaction is determined by the diffusion of the two components through this layer. This, naturally, slows down the reaction appreciably.

PERITECTIC REACTIONS UNDER NONEQUILIBRIUM CONDITIONS

When an alloy cools through a peritectic reaction too rapidly for conditions of true equilibrium to obtain, three phases may occur in apparent equilibrium in its microstructure even though only one of them is stable under true equilibrium conditions. For the general example cited these will be (a) solid III, (b) “chilled” form of liquid II, and (c) a “reaction zone” of solid I which will envelop the solid III crystals.

To illustrate this further consider, as before, the specific example of an alloy containing equal amounts of antimony and tin. Solidification again begins by the formation of crystals of  $\beta$  solid solution. However, cooling is now so rapid that there is no time for the peritectic reaction at 615 F (325 C) to proceed to completion. Some  $\beta'$  will be formed, by envelopment,

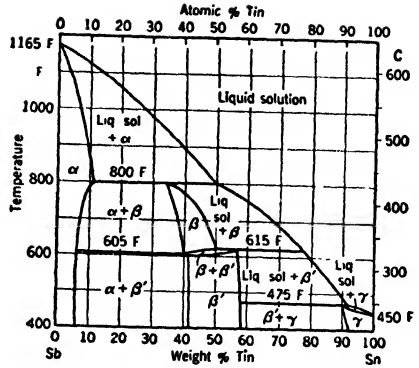


FIGURE 205. Constitutional diagram typical of binary alloys in which peritectic reactions occur: the alloys of antimony and tin. (After M. Hansen.)

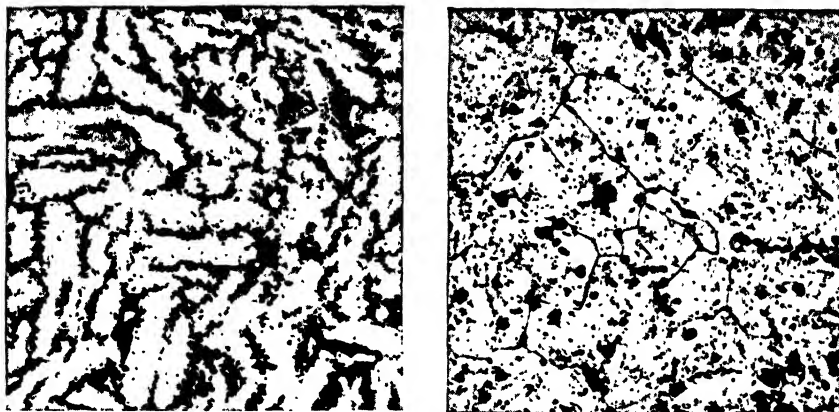


FIGURE 206. Metallographic structure of an alloy of 50% Sb — 50% Sn. Etched with ferric chloride.  $\times 200$ . (Photomicrographs by L. Litchfield.)

*a. (Left)* After chill casting. The white crystals are  $\beta$  solid solution, the darker edges of which have reacted with liquid to form  $\beta'$ . The dark etching regions are either voids or small patches of rapidly cooled liquid (now a finely dispersed mixture of  $\beta'$  and  $\gamma$  solid solutions).

*b. (Right)* Crystals of  $\beta'$  after heating for several hours at 525 F (275 C) and slowly cooling. The dark areas are largely voids, inclusions, and etching pits.

at the surface of the  $\beta$  crystals as the temperature passes through that of the peritectic reaction, but likewise some liquid will have no opportunity to react and, therefore, will solidify and appear as a finely dispersed mixture of  $\beta'$  and  $\gamma$  solid solutions.

The structure of the alloy cooled under these nonequilibrium conditions is shown in Fig. 206*a*. The unetched cores of the crystals are probably the initially formed  $\beta$ , the lightly etched boundary regions the  $\beta'$  formed by interaction of  $\beta$  with the remaining liquid, and the dark regions a finely dispersed mixture of  $\gamma$  and  $\beta'$  formed from the solidified liquid.

If the alloy is reheated for several hours at a temperature just below that of the peritectic horizontal, or if the original solidification is sufficiently slow to permit the peritectic reaction to proceed to completion, the completely uniform and homogeneous  $\beta'$  secondary solid solution shown in Fig. 206*b* will result.

#### MORE COMPLEX DIAGRAMS

Only three examples of more complex diagrams will be mentioned here, although additional examples are given later in the text.<sup>11</sup> The first two are the somewhat similar diagrams, copper-zinc (Fig. 207) and copper-tin

<sup>11</sup> See Fig. 415 for example.

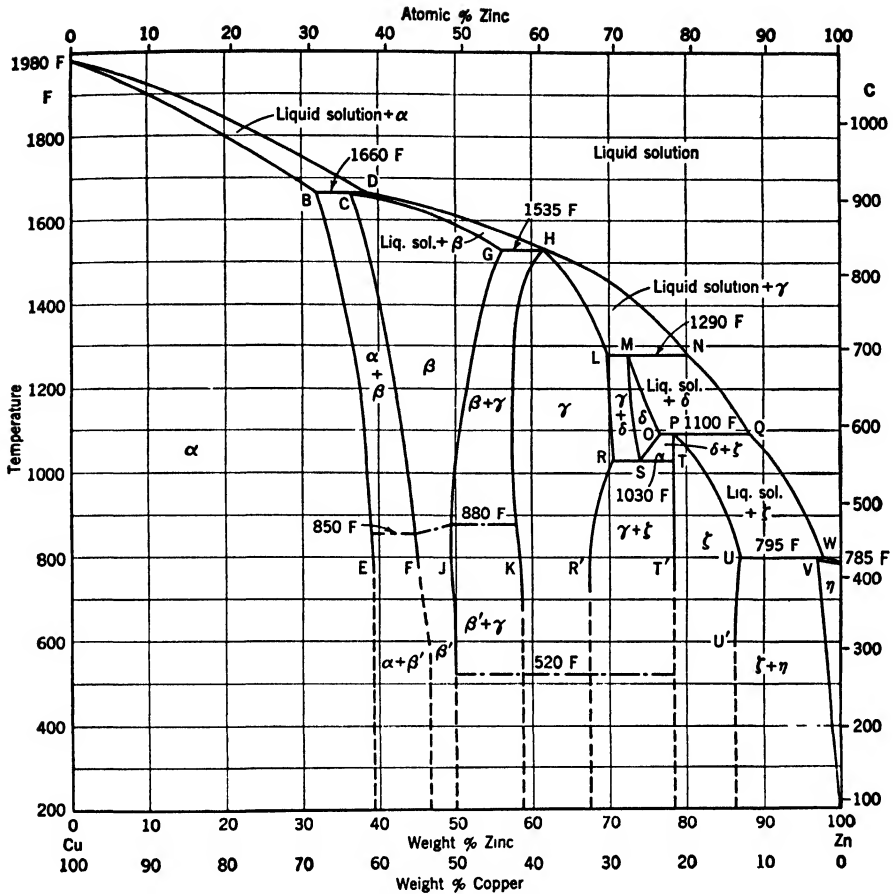


FIGURE 207. Constitutional diagram for the alloys of copper and zinc: the brasses. (After M. Hansen.)

(Fig. 208), which indicate the constitution of the commercially important *brasses* and *bronzes*, respectively; the third is the iron-carbon diagram which expresses similar data for *steel* and *cast iron*.

There are a number of single-phase areas on each of the first two diagrams which customarily are indicated by the Greek letters:  $\alpha$ ,  $\beta$ ,  $\gamma$ ,  $\delta$ ,  $\epsilon$ , etc. However, from the known nature of the general properties of secondary solid solutions and intermetallic compounds, it would be expected that only comparatively small portions of these diagrams would be of commercial significance. These portions are shown in Fig. 209. It will be seen at once that, for each of the diagrams, the important regions consist essentially of only two fields, one containing the copper-rich primary solid solution ( $\alpha$ ) and one containing a mechanical mixture of two solid solutions, one primary and one secondary ( $\alpha$  and  $\beta$ ). It will be noticed that in both of these



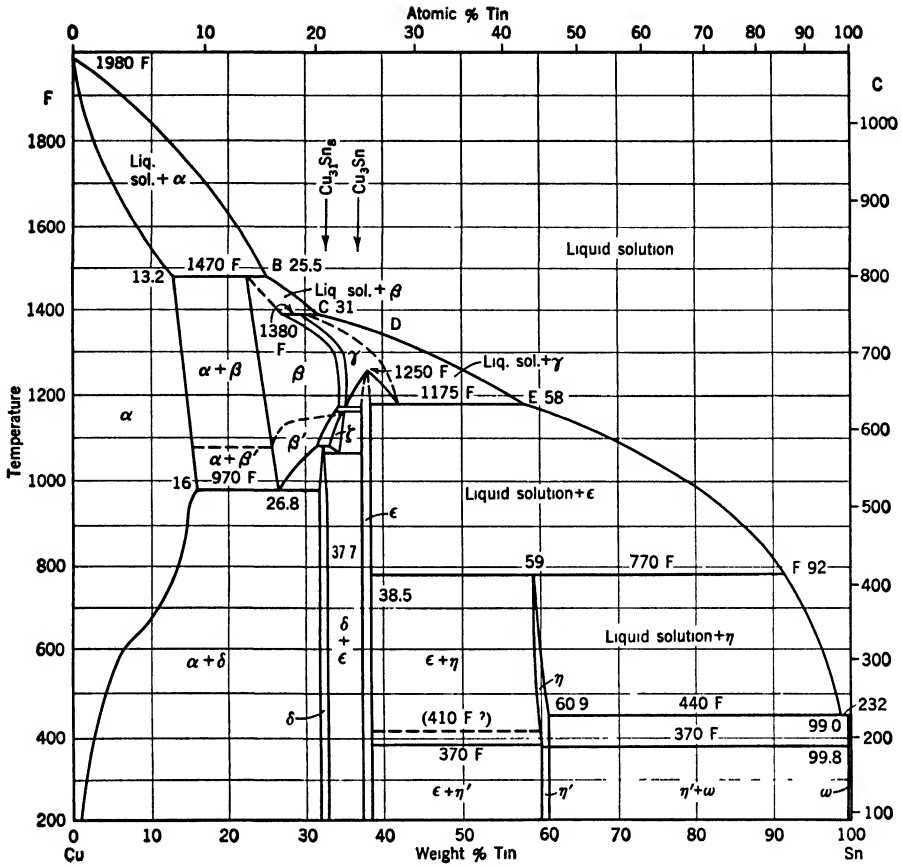


FIGURE 208. Constitutional diagram for the alloys of copper and tin: the bronzes. (After M. Hansen.)

diagrams the solid solubility of either zinc or tin in copper increases as the temperature decreases, although in the copper-tin system this is a condition which persists only down to about 1000 F (540 C). In the bronzes, therefore, it is quite possible to have an alloy, such as the one containing about 62% Cu-38% Zn, which, immediately after solidification, is composed entirely of the secondary,  $\beta$ , solid solution, and yet which, at room temperature, is composed entirely of the primary,  $\alpha$ , solid solution.

A somewhat similar set of conditions exists for the alloy containing approximately 58% Cu-42% Zn, which is, however,  $\beta$  at the high temperature and a mixture of  $\alpha$  and  $\beta$  at the low temperatures. The structural changes that would result in this latter alloy by cooling rapidly from a high temperature, and then reheating at various lower temperatures, are indicated by the photomicrographs shown in Fig. 210.

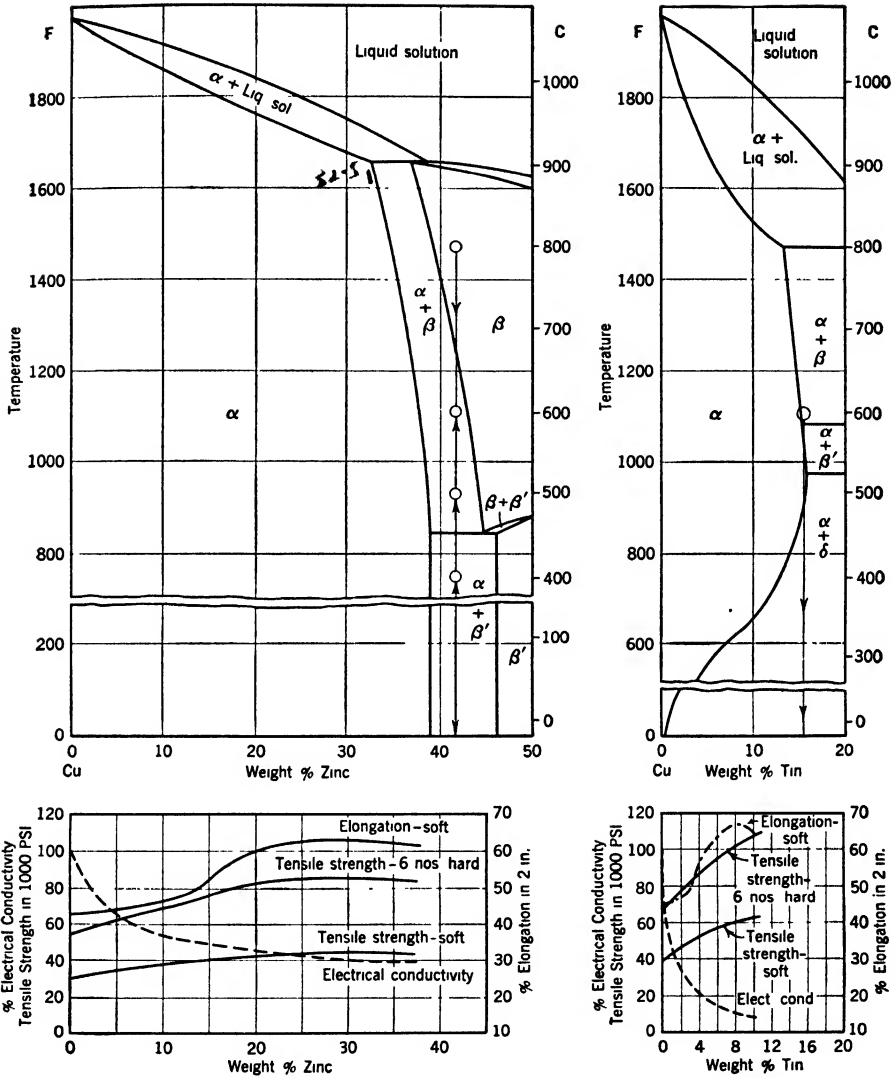


FIGURE 209. (Upper) Commercially important portions of the copper-zinc and copper-tin constitutional diagrams. The temperatures indicated by points on the constant composition line, 58% Cu-42% Zn, refer to the treatments used to produce the structures shown in Fig. 210. (Lower) Effects of composition on the properties of the commercial brasses and bronzes. (Courtesy Bridgeport Brass Company.)

The changes in properties of the copper-zinc and copper-tin alloys, with composition, also are indicated in Fig. 209. It will be noticed that the copper-rich alloys follow, in general, the trends which would be expected for a solid solution. The thermal and electrical conductivities decrease,

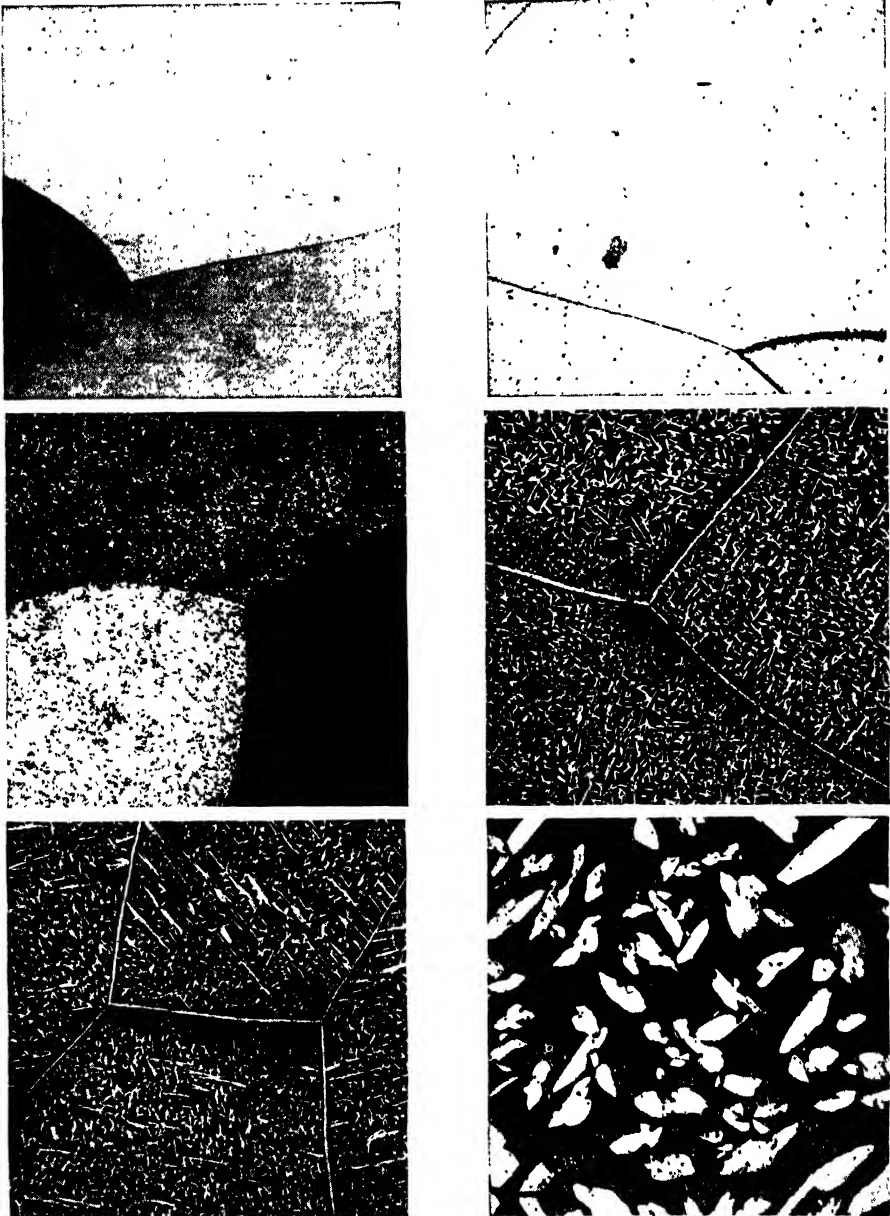


FIGURE 210. Photomicrographs illustrating the effects of heat-treatment on the microstructure of the alloy 58% Cu-42% Zn.  $\times 100$ .

*a.* (Top left) As quenched from 1470 F (800 C). Etched with  $\text{NH}_4\text{OH} + \text{H}_2\text{O}_2$ . (Photomicrograph by A. J. Calpaxis.) The structure is completely  $\beta$  secondary solid solution.

*b.* (Top right) Quenched and reheated  $\frac{1}{2}$  hr at 390 F (200 C). Etched with  $\text{NH}_4\text{OH} + \text{H}_2\text{O}_2$ . (Photomicrograph by J. Caplan.) Very small particles of dark etching  $\alpha$  have started to precipitate within the  $\beta$  grains.

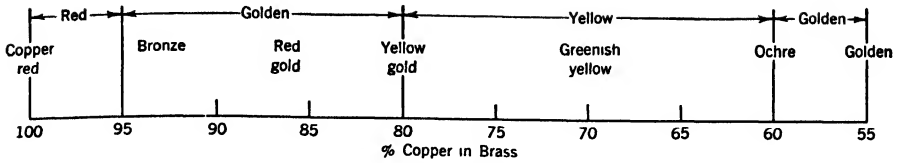


FIGURE 211. Schematic representation of the change of color with zinc content in the commercial brasses.

at a rate which becomes smaller as the percentage zinc or tin increases, and the strengths and hardnesses of the alloys increase. The cold-workability of these alloys, especially those of copper and zinc, is high over the entire  $\alpha$  range, but decreases markedly as the percentage of the brittle  $\beta$  phase increases in the two-phase field.

The color of the copper-zinc alloys changes markedly with zinc content as indicated in Fig. 211. Small percentages, up to about 5% zinc, have little effect on the red copper color. At 5–10% zinc a bronze color appears which merges into a red-gold color at 15% zinc and a yellow-gold at about 20% zinc. From about 25–38% zinc, the alloys have the typical greenish-yellow brass color, and from 38–45% zinc, they again take on a somewhat reddish cast, passing through ochre into another series of gold hues.

The corrosion resistance of all the brasses is quite good but the optimum properties seem to lie in the vicinity of 85% Cu–15% Zn, and little real advantage results from a further increase in copper content. The commercial brasses, containing copper and zinc alone, are standardized well in present-day practice, and will be discussed in more detail later.

The effect of tin upon the properties of copper is more marked than that of zinc, the strength and hardness increasing and the workability decreasing rapidly with increasing tin content. As a result, the limit of the commercially important alloys is about 10% tin. The copper-tin alloys sometimes are termed *phosphor bronzes* since phosphorus, as phosphor-copper or phosphor-tin, frequently is used as a deoxidizing agent. Because of the

- c. (Middle left)* Quenched and reheated  $\frac{1}{2}$  hr at 570 F (300 C). Etched with  $\text{NH}_4\text{OH} + \text{H}_2\text{O}_2$ . (Photomicrograph by L. C. Cavalier.) The number and size of the dark etching  $\alpha$  particles have increased with a concomitant increase in the rate of etching.
- d. (Middle right)* Quenched and reheated  $\frac{1}{2}$  hr at 750 F (400 C). Etched with Grard's No. 2 to darken the  $\beta$ . (Photomicrograph by J. W. Fissel.) The light etching  $\alpha$  precipitate is coarsening and assuming a definite geometrical pattern.
- e. (Bottom left)* Quenched and reheated  $\frac{1}{2}$  hr at 930 F (500 C). Etched with Grard's No. 2 to darken the  $\beta$ . (Photomicrograph by G. H. Ebbs.) The light etching  $\alpha$  continues to coarsen and conforms to the regular geometrical pattern even more markedly. Photomicrographs *d* and *e* are examples of the *Widmannstaetten* type of structure.
- f. (Bottom right)* Quenched and reheated  $\frac{1}{2}$  hr at 1110 F (600 C). Etched with Grard's No. 2 to darken the  $\beta$ . (Photomicrograph by R. Stemmler.) The light etching  $\alpha$  particles are now very coarse although remnants of their geometrical arrangement still can be seen. The background is probably a finely dispersed mixture of  $\alpha$  and  $\beta$ .

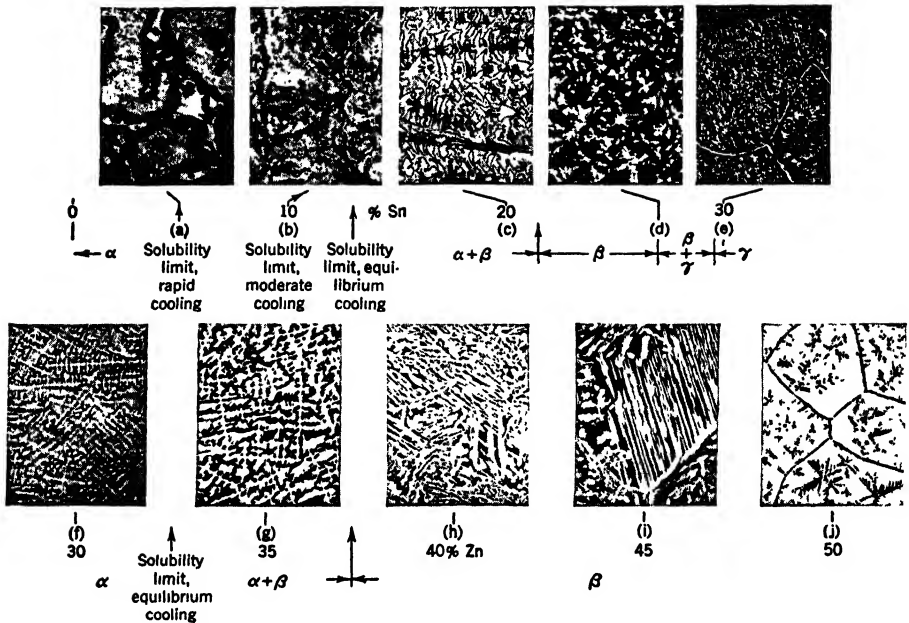


FIGURE 212. Metallographic structures of copper-tin (upper) and copper-zinc (lower) alloys in the "as-cast" condition illustrating coring and the apparent shift in the solidus line resulting from incomplete diffusion. Unless otherwise indicated, the phase fields are those existing just after solidification under equilibrium conditions. Original magnifications given, reduced about one half in reproduction.

#### Copper-tin alloys.

*a.* 95% Cu – 5% Sn. Etched with  $\text{NH}_4\text{OH} + \text{H}_2\text{O}_2$ .  $\times 500$ . In these alloys the transformations  $\gamma \rightarrow \beta$  and  $\beta \rightarrow \alpha + \delta$  nearly always tend to occur in the solid alloys during cooling. (Photomicrograph by J. T. Mackenzie, Jr.)

Note the appearance of very small particles of  $\delta$  secondary solid solution ( $\text{Cu}_4\text{Sn}$ ) in the dendrites richer in tin even though, after equilibrium solidification, this alloy should fall within the  $\alpha$  primary solid solution field. The presence of  $\delta$  is clear evidence of the presence of some  $\beta$  in the alloy just after solidification.

*b.* 90% Cu – 10% Sn. Etched with  $\text{NH}_4\text{OH} + \text{H}_2\text{O}_2$ .  $\times 500$ . (Photomicrograph by C. L. McVicker.) Although this alloy also should fall within the  $\alpha$  field comparatively large particles of the  $\delta$  constituent can be seen readily in a cored solid solution matrix. The rate of solidification was undoubtedly rapid enough to form some  $\beta$  which then decomposed during cooling.

*c.* 80% Cu – 20% Sn. Etched with Grard's No. 1.  $\times 200$ . (Photomicrograph by G. W. Brown.) The  $\alpha$  dendrites and particles of the  $\delta$  constituent can be seen readily even at this low magnification. Even with equilibrium solidification this alloy should contain considerable  $\beta$  which then would transform to  $\alpha$  and  $\delta$  during cooling.

*d.* 73% Cu – 27% Sn. Etched with Grard's No. 1.  $\times 500$ . (Photomicrograph by A. J. Calpaxis.) Particles of light etching  $\delta$  in an unresolved matrix composed either of  $\alpha$  or of a mechanical mixture of  $\alpha$  and  $\delta$ . This structure should correspond nearly to the eutectoid composition but undoubtedly has been modified during solidification and cooling to give the appearance of a somewhat higher tin content.

*e.* 70% Cu – 30% Sn. Etched with 5% ferric chloride.  $\times 200$ . (Photomicrograph by R. F. Hancock.) Because of the transformation:  $\beta \rightarrow \alpha + \delta$  which takes place after

coring occurring in these alloys during solidification, and the consequent disturbance of the diagram, as has been discussed already, the  $\delta$  constituent ( $\text{Cu}_4\text{Sn}$ ) sometimes is found in the cast alloys, and even in worked alloys that have not been homogenized completely. The presence of this constituent makes the material rather brittle and difficult to work, although it increases the hardness, yield strength, and bearing characteristics appreciably.

#### MICROSTRUCTURE

Some metallographic structures of commercial brasses and bronzes in the "as-cast" condition are shown in Fig. 212. The effects of coring and of displacement of the solidus as a result of incomplete diffusion readily can be recognized in the higher copper alloys.

The  $\alpha$  solid solutions of copper-base alloys and, in general, those of all other face-centered cubic metals except aluminum, which also is shown for comparison in Fig. 213*b*, have twinned metallographic structures, similar to that shown in Fig. 213*a*, after they have been homogenized properly. The polyhedral grains contain numerous annealing twin bands which give them a characteristic appearance.

The  $\beta$  constituent in the copper-zinc system is a light lemon-yellow in color when etched with the usual reagent, a mixture of ammonium hydroxide and hydrogen peroxide (Fig. 214*a*). Etching with ferric chloride (Fig. 214*b*) causes this constituent to darken appreciably.

---

solidification, this structure is nearly normal. Excess  $\delta$  constituent at the boundaries, geometrically dispersed particles of light etching  $\delta$  in a matrix of dark etching  $\alpha$  within the grains.

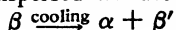
Copper-zinc alloys.

*f.* 70% Cu — 30% Zn. Etched with Grard's No. 1.  $\times 100$ . (Photomicrograph by T. S. Luerssen.) A small amount of dark etching  $\beta$  has been formed in cored regions of the  $\alpha$  solid solution because of coring and the solidus displacement resulting from non-equilibrium cooling. No transformation to  $\alpha$  on cooling apparent at this magnification.

*g.* 65% Cu — 35% Zn. Etched with Grard's No. 1.  $\times 100$ . (Photomicrograph by C. M. Campbell.) The amount of dark etching  $\beta$  has increased as the copper content decreased. No transformation to  $\alpha$  on cooling apparent at this magnification.

*h.* 60% Cu — 40% Zn. Etched with Grard's No. 1.  $\times 100$ . The  $\beta$  formed on solidification has transformed on cooling, precipitating large needles of light etching  $\alpha$ . Except for the large particles, this structure is nearly normal.

*i.* 55% Cu — 45% Zn. Etched with Grard's No. 2.  $\times 100$ . This structure is quite similar to that of the 60:40 alloy except that the dark etching background, which is now more noticeable, is a finely dispersed mixture of  $\alpha$  and  $\beta'$  formed by the reaction:



*j.* 50% Cu — 50% Zn. Etched with  $\text{NH}_4\text{OH} + \text{H}_2\text{O}_2$ .  $\times 100$ . (Photomicrograph by R. R. Sterner.) A few small dark etching particles of  $\gamma$  have precipitated during cooling both at the grain boundaries and on a geometrical pattern within the  $\beta$  grains. This structure also is nearly normal but indicates that the actual analysis is probably a little higher in zinc than the 50% shown above.

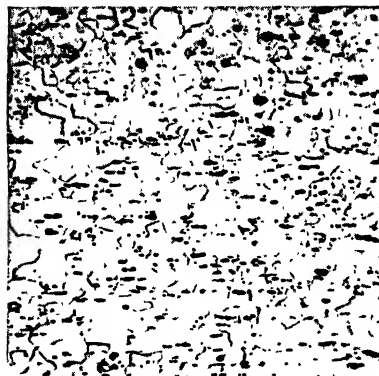
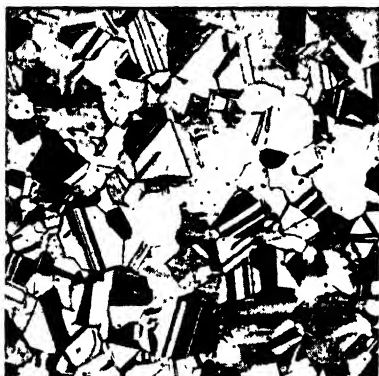


FIGURE 213. Photomicrographs typical of face-centered cubic metals and solid solutions.

*a.* (Left) Annealed cartridge brass (70% Cu — 30% Zn) showing the twinned structure which most commonly is found with this type of space lattice. Etched with  $\text{NH}_4\text{OH} + \text{H}_2\text{O}_2$ .  $\times 75$ .

*b.* (Right) Commercial annealed aluminum, Alcoa 2S-O, the only common face-centered cubic metal in which annealing twins do not occur. The small dark regions are largely impurities. Etched with  $\frac{1}{2}\%$  HF.  $\times 100$ . (Photomicrograph courtesy Aluminum Research Laboratories.)

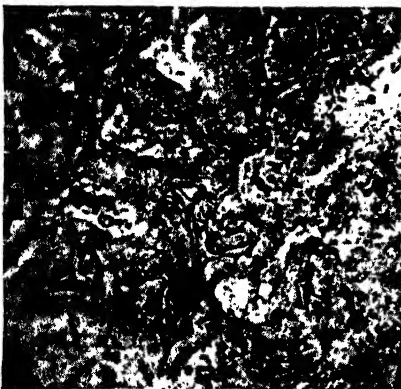
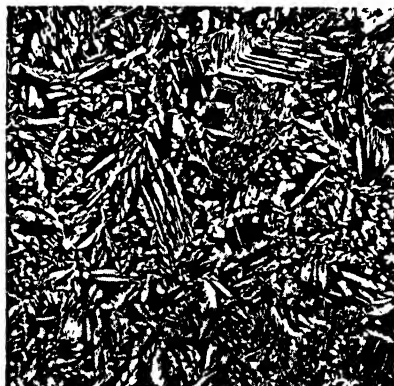
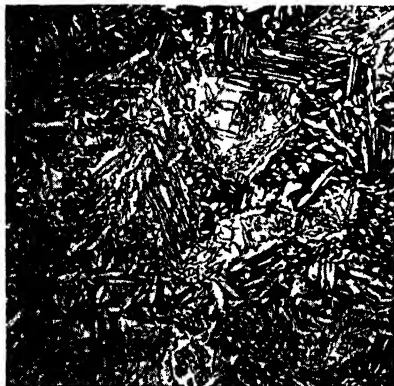


FIGURE 214a. (Upper left) Photomicrograph of  $\alpha$ - $\beta$  brass, Muntz metal (60% Cu—40% Zn). Etched with  $\text{NH}_4\text{OH} + \text{H}_2\text{O}_2$ .  $\times 75$ . Cf. Fig. 413.

*b.* (Upper right) Photomicrograph of  $\alpha$ - $\beta$  brass, Muntz metal (60% Cu—40% Zn). Etched with  $\text{NH}_4\text{OH} + \text{H}_2\text{O}_2$  followed by acid ferric chloride to darken the  $\beta$ .  $\times 75$ . Cf. Fig. 413.

*c.* (Lower left) Photomicrograph of  $\delta$ -bronze constituent ( $\text{Cu}_4\text{Sn}$ ) in an  $\alpha$ -bronze matrix in an alloy of 90% Cu—10% Sn. Etched with  $\text{NH}_4\text{OH} + \text{H}_2\text{O}_2$ .  $\times 500$ . (Photomicrograph by C. L. McVicker.)

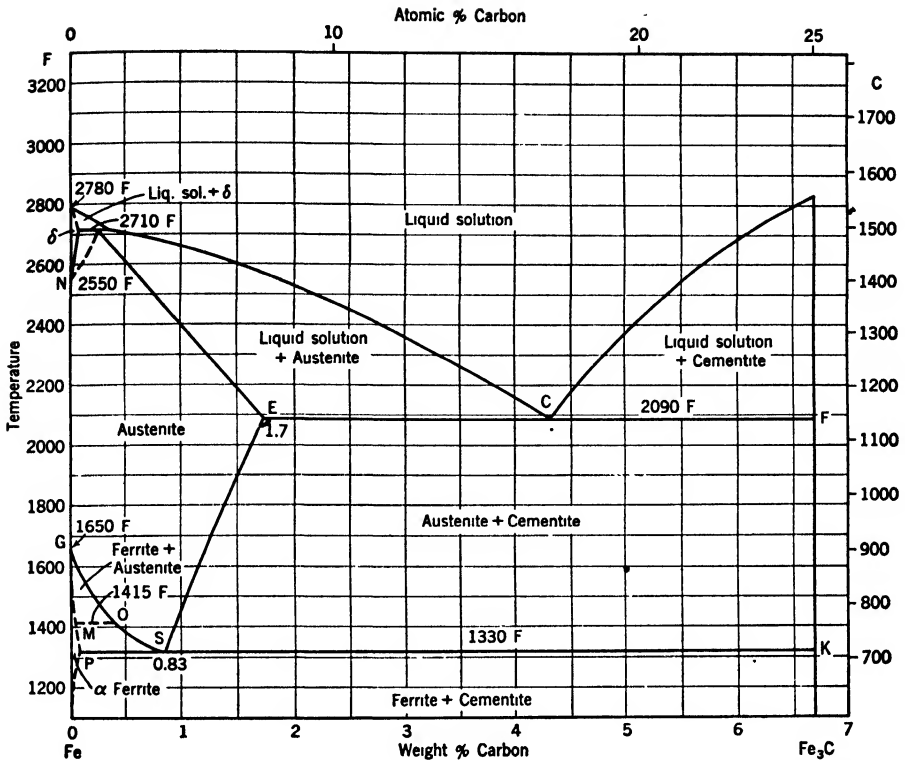


FIGURE 215. Constitutional diagram for the alloys of iron and iron carbide: the steels and white cast irons. (After M. Hansen.)

The  $\delta$  constituent in the copper-tin system is bluish in color under the microscope and usually occurs in quite small particles so that a fairly high magnification may be required to resolve it (Fig. 214c).

#### THE IRON-CARBON DIAGRAM

The so-called iron-carbon diagram,<sup>12</sup> which is the basis for rationalizing the treatment and structure of steels and cast irons, is complex because of the nature of the metal iron rather than because of the number of phases that can be formed. In this respect, it differs from the copper-zinc and copper-tin diagrams. Experimental difficulties have permitted the study of the system only up to about 5% carbon, and little or nothing is known beyond 6.67% carbon, which is the composition of the carbide of iron, Fe<sub>3</sub>C.

From Figs. 215 and 216 it can be seen that there are only three significant single-phase areas in addition to the liquid solution of carbon in iron.

<sup>12</sup> See, for a thorough discussion, S. Epstein, *The Alloys of Iron and Carbon, Vol. I—Constitution*: McGraw-Hill Book Company, Inc., New York, 1936.



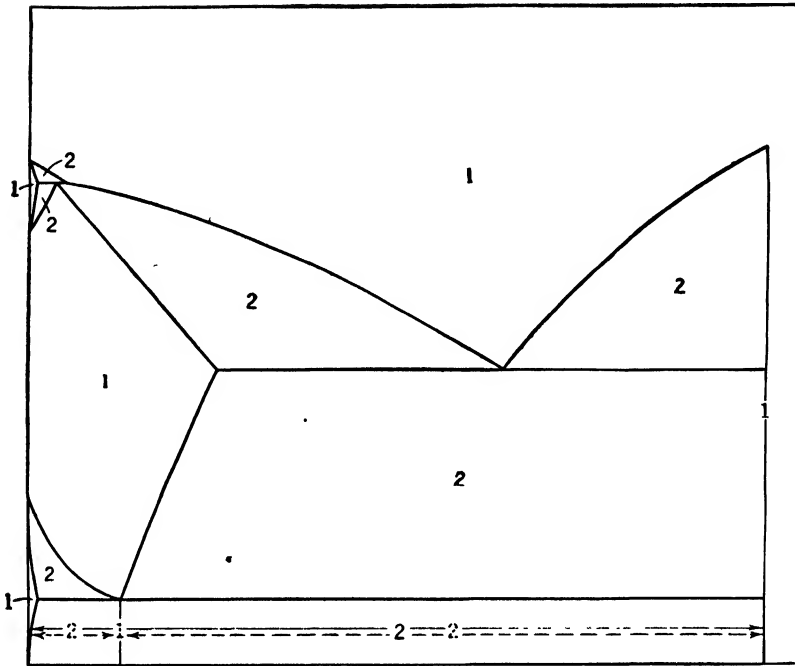


FIGURE 216. Application of the 1:2:1 rule to the constitutional diagram for the alloys of iron and iron carbide.

Because of their importance commercially, all of these phases have been given characteristic names:

1. *Ferrite* (from the Latin *ferrum*), commercially pure alpha iron containing a maximum of about 0.04–0.05% carbon in solid solution.
2. *Austenite* (named for the English metallurgist Sir Roberts-Austen), an interstitial primary solid solution of carbon in gamma iron containing a maximum of about 1.7% carbon at 2090 F (1140 C) and of about 0.83% carbon at 1330 F (725 C).
3. *Cementite* (from the Latin *caementum*), the iron carbide, Fe<sub>3</sub>C, containing 6.67% carbon, which probably melts or decomposes at a temperature which may be in excess of 3450 F (1950 C) (cf. Fig. 222) and is thermodynamically unstable below about 2200 F (1200 C).

The peritectic reaction occurring near the melting point of iron is of no commercial importance, and can be omitted from consideration here, although it does result in a fourth single-phase area, viz. delta iron.

In addition, there is an eutectic at about 4.3% carbon and 2090 F (1140 C), known as *ledeburite*, the characteristic eutectic structure of which is shown in Fig. 217. This constituent, too, is of little commercial importance except in white cast irons.

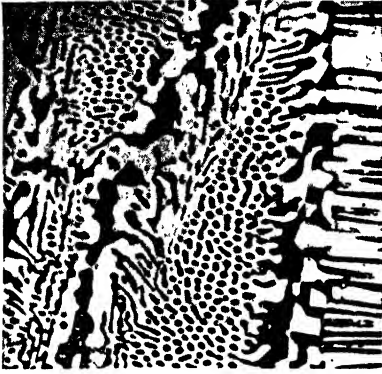
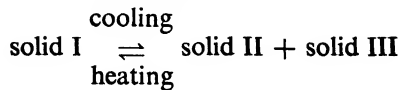


FIGURE 217. (*Left*) Metallographic structure, typical of the iron-iron carbide eutectic *ledeburite*, produced by melting commercially pure ingot iron under graphite. Etched with nital.  $\times 500$ . (Photomicrograph by M. C. Fetzer.) Cf. Fig. 195*b*. The light etching regions are cementite and the dark etching regions are unresolved transformed austenite, i.e., pearlite.

FIGURE 218. (*Right*) Metallographic structure typical of the solid solution of carbon in gamma iron, *austenite*.  $\times 100$ . In plain carbon steels this constituent is stable only above  $A_1$ . The structure shown is that of an 18% chromium, 8% nickel austenitic stainless steel.

#### THE EUTECTOID

It will be noticed that at a temperature of 1330 F (725 C) and about 0.83% carbon, the diagram has a configuration very similar in appearance to that of an eutectic transformation. However, whereas in the eutectic transformation a liquid solution transforms at a constant temperature into a mixture of two solid solutions, in the present case a solid solution exists above the "V" on the diagram. This type of a transformation is somewhat different, and is known as an eutectoid. It may be described either as *the solid solution transforming at the lowest temperature into a mixture of two other solid solutions*, or by the equation:



In the case of the iron-carbon alloys, this transformation is exceedingly important. Above 1330 F (725 C), an alloy containing 0.83% carbon and the remainder essentially iron is composed of the stable solid solution of carbon in face-centered cubic iron which has been called *austenite*. This phase would have a microstructure similar to that shown in Fig. 218 if it were stable at room temperature. The characteristic annealing twin bands of the face-centered cubic solid solution (based on gamma iron) are clearly evident. As the alloy cools through the critical range in the vicinity of

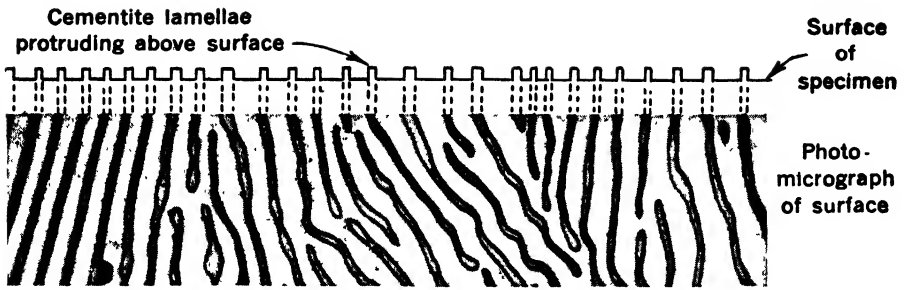
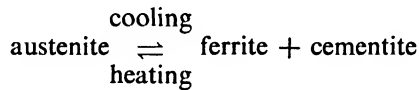


FIGURE 219. Schematic representation of a cross section through a patch of pearlite,  $\times 2500$ , illustrating the grating produced by etching which gives this constituent its iridescent appearance.

1330 F (725 C) a transformation occurs which may be expressed, specifically, by the equation:



Under equilibrium conditions this transformation takes place at a constant temperature exactly as does the similar eutectic transformation. After transforming under equilibrium conditions, the alloy is composed of a mechanical mixture of alternate plates or lamellae of the two phases, ferrite and cementite, arranged as in the photomicrograph shown in Fig. 220a. Since the solid solubilities of carbon in alpha iron and of iron in cementite are extremely small, this eutectoid will remain practically unchanged during its subsequent cooling to room temperature. It is convenient, therefore, to call this constituent, which also was discovered by Sorby, *pearlite* or *pearly constituent*, since when etched it frequently exhibits a display of colors very suggestive of mother-of-pearl. The reason for this can be comprehended from the diagram shown in Fig. 219, in which the cross section of a patch of pearlite is idealized. The layers of either constituent are seldom more than 0.00004 in. in thickness, so pearlite will affect light in a manner somewhat similar to a diffraction grating because of the fact that the harder carbide particles will stand out in relief after polishing and etching. White light striking a surface such as this will be broken up into its constituent colors, thus giving it a pearly or iridescent appearance.

Although pearlite is, in reality, a mechanical mixture of two phases, as has been noted already, it is in itself so important that it frequently is considered to be a separate constituent in slowly cooled steels. This is, of course, purely a matter of convenience and can be done only because it is so readily distinguished under the microscope, even though its lamellae may not be resolved, as in Fig. 220b.

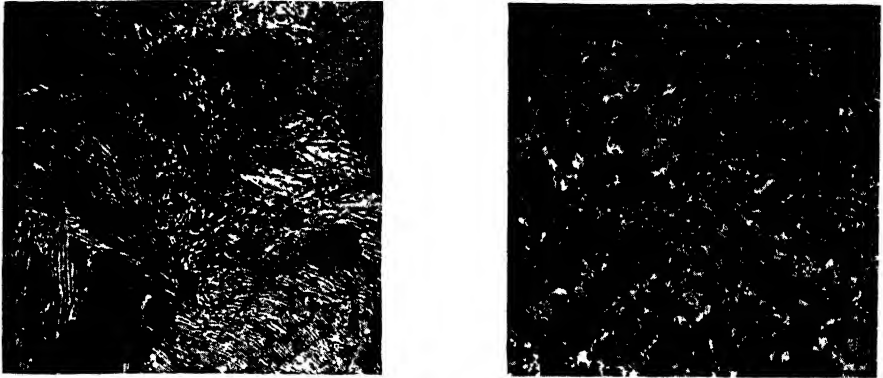


FIGURE 220. Metallographic structures typical of the iron-iron carbide eutectoid, *pearlite*. Etched with nital. Cf. Figs. 225 and 254a.

- a. (Left)  $\times 250$ , showing its lamellar nature resolved.  
 b. (Right)  $\times 100$ , showing the majority of the lamellae unresolved.

Steels containing less carbon than the eutectoid composition are said to be *hypoeutectoid*, whereas those containing carbon between the eutectoid composition and the limit of solid solubility (about 1.7% carbon) are said to be *hypereutectoid*. In addition, any ferrite or cementite existing in the alloy in excess of that required to form pearlite is referred to as *proeutectoid* or *free ferrite* or *cementite*, as the case might be. The name *proeutectoid* arises, of course, from the fact that the “excess” phase is precipitated, during cooling, ahead of or before the separation of the eutectoid.

#### REACTION TO ETCHING OF CONSTITUENTS IN IRON-CARBON ALLOYS

Three etching reagents are used most commonly to delineate the constituents of the slowly cooled iron-carbon alloys.<sup>13</sup> These are, respectively, (a) *nital*, a water-free solution of 2–4% nitric acid in either methyl or ethyl alcohol; (b) *picral*, a solution of 2–5% picric acid in ethyl alcohol; and (c) *alkaline sodium picrate*, a solution of 2 g picric acid and 25 g sodium hydroxide in 100 ml water. Other reagents are given in A.S.T.M. Tentative Standard E3-T.

When properly etched with nital, the pearlite colonies will be darkened, and the grain boundaries of the ferrite will be outlined clearly. Both ferrite and cementite will appear white after etching.

The action of picral is similar, except that it etches fine pearlite much more uniformly than nital does. However, it does not etch ferrite so rapidly

<sup>13</sup> See J. R. Vilella, *Metallographic Technique for Steel*: Amer. Soc. for Metals, Cleveland, Ohio, 1937.

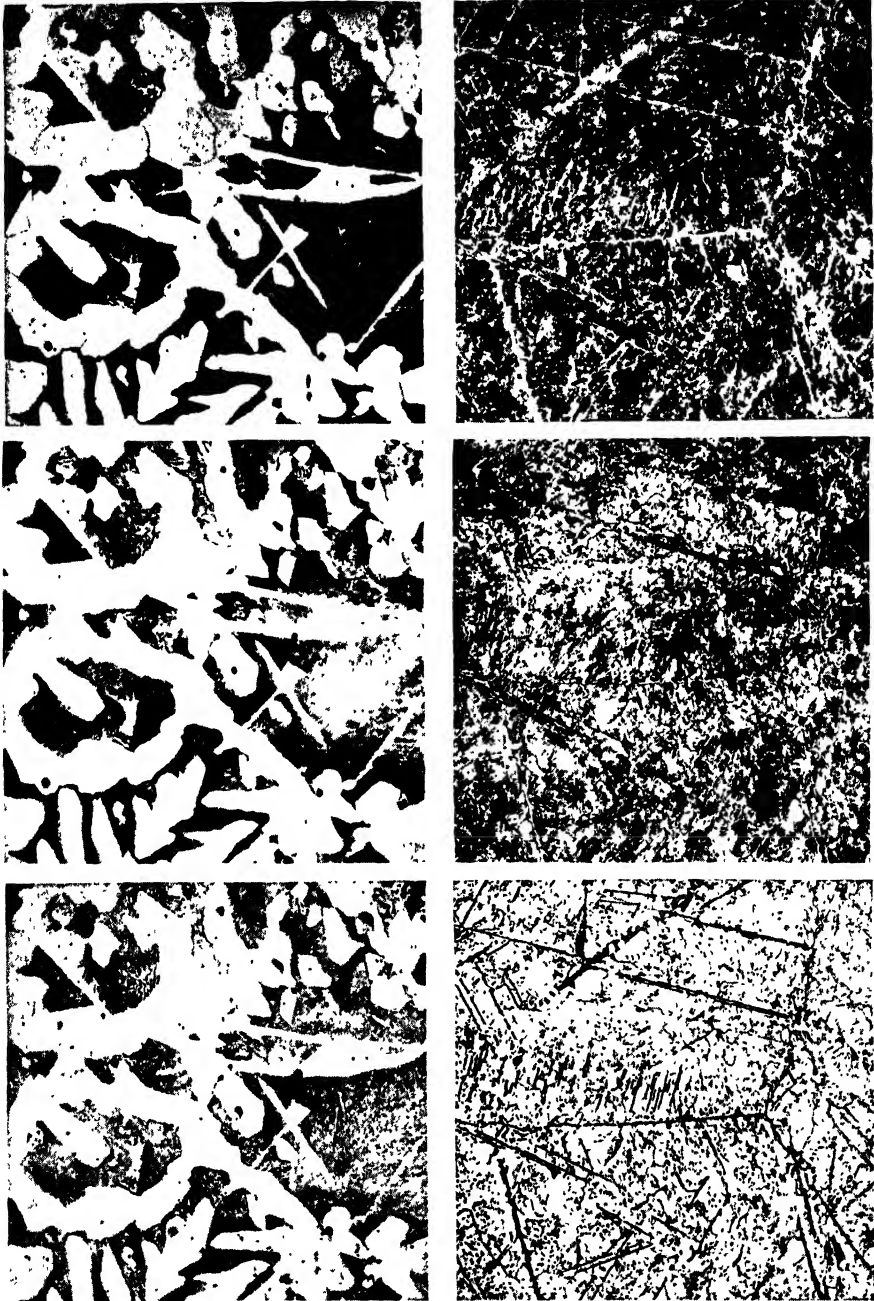


FIGURE 221. Metallographic structures of a 0.5% carbon hypoeutectoid (*left*) and a 1.2% carbon hypereutectoid (*right*) steel after etching with nital (*upper*), picral (*middle*), and alkaline sodium picrate (*lower*).  $\times 100$ . Portions of three very large grains are

as nital, and hence does not indicate the ferrite grain boundaries clearly. As before, both ferrite and cementite appear white after etching, and pearlite appears dark.

The alkaline sodium picrate is used, either electrolytically or by boiling the specimen in it, to differentiate between cementite and ferrite. Ferrite is unattacked, and, therefore, appears white after etching, whereas the cementite is attacked and darkened.

The appearance of typical slowly-cooled hypo- and hypereutectoid carbon steels after etching with each of these three reagents is illustrated in Fig. 221.

#### TRANSFORMATION NOMENCLATURE

The nomenclature used in the discussion of the transformations in pure iron is carried over to the steels with but few changes. As previously noted, the  $A_4$  transformation is of little commercial importance and will not be discussed. The  $A_3$  transformation, during which gamma iron changes to alpha iron on cooling, becomes in the steels the line  $GSK$  on the diagram shown in conventional form in Fig. 215 and as redrawn with a distorted composition scale in Fig. 222. This decreases in temperature from  $A_3$  for pure iron to the eutectoid composition, and then follows the eutectoid temperature. The  $A_2$  transformation, during which alpha iron regains its ferromagnetism on cooling, proceeds nearly horizontally from the  $A_2$  transformation in pure iron until it strikes and merges with the  $A_3$  line,  $GS$ , at the point  $O$ . The  $A_1$  transformation, which is not found in pure iron, is the eutectoid temperature, the lowest temperature at which austenite can exist in a stable form. It is shown as the line  $PSK$ , corresponding to the eutectoid temperature, 1330 F (725 C). The  $A_0$  transformation, which is not shown but occurs at about 390 F (200 C), usually is considered to be caused by a magnetic change in cementite, although this has not been established definitely and it may result from some sort of change in the iron atom. *Only the  $A_3$  and  $A_1$  transformations are of real importance commercially.*

#### STRUCTURAL CHANGES DURING SLOW COOLING OF A HYPOEUTECTOID STEEL

Consider, for purposes of illustration, a *constructional steel* containing about 0.25% carbon and no impurities (Fig. 223). Immediately after

---

shown in the hypereutectoid steel with proeutectoid, or free, cementite appearing both at the grain boundaries and as plates precipitated on a geometrical pattern within the original (austenite) grains.

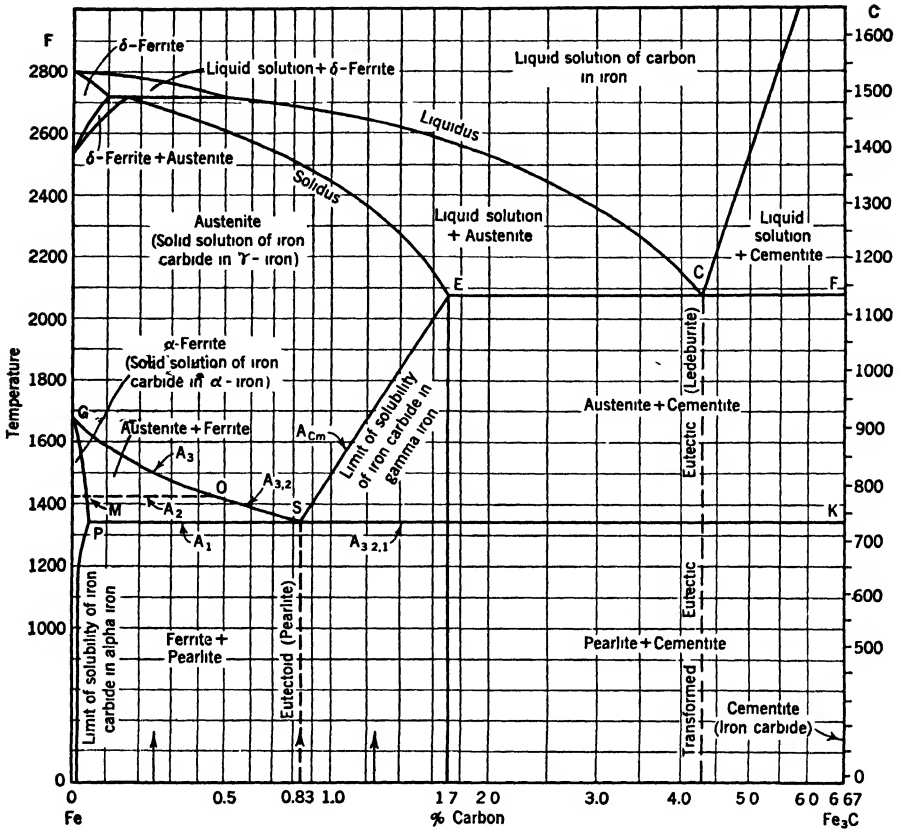


FIGURE 222. Constitutional diagram for the alloys of iron and iron carbide drawn with a distorted composition scale in order to place greater emphasis on the constitution of the steels. (After *Metal Progress*.)

The arrows on the composition axis correspond to the compositions discussed in Figs. 223, 224, 226.

solidification from the structureless liquid state, this alloy will consist entirely of coarse-grained austenite, a solid solution of carbon in gamma iron, and both its composition and structure should become reasonably uniform quickly because of the comparatively rapid diffusion of carbon at the high temperatures involved. No change, except possible further homogenization, will take place in this austenite until, on cooling, the alloy arrives at the temperature of the  $A_3$  transformation, i.e., until the constant composition line at 0.25% carbon intersects the line,  $GS$ , on the constitutional diagram. At this temperature a transformation begins. The austenite which is stable below this temperature contains an appreciably greater amount of carbon than the original austenite which was formed from the liquid and is stable above this temperature. Therefore, it must dispose of

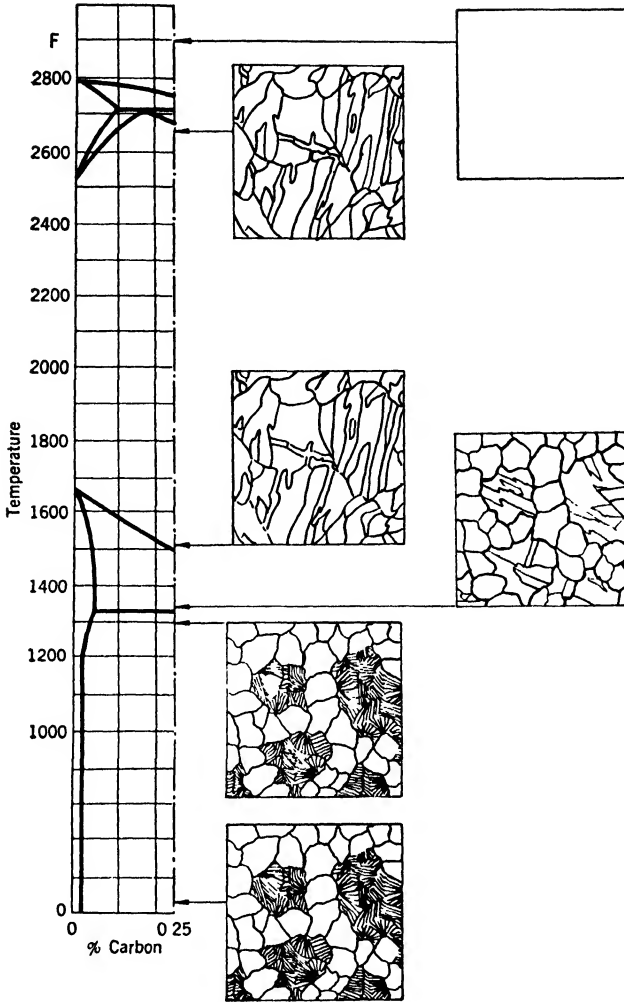


FIGURE 223. Schematic illustration of the structural changes in a 0.25% carbon constructional steel as it cools slowly to room temperature from the liquid state.

some of the iron which it was able to retain in solid solution above this transformation temperature. It does this by precipitating it, in the solid alloy, as body-centered cubic alpha iron at the grain boundaries of the austenite grains. This process of precipitation of alpha iron at the austenite grain boundaries and enrichment of the remaining austenite in carbon will continue until the  $A_1$  transformation is reached at about 1330 F (725 C). At this temperature, the remaining austenite contains the maximum amount of dissolved carbon, approximately 0.83%, because it will have precipitated at its grain boundaries the maximum possible amount of



alpha ferrite. At this temperature, therefore, the austenite of eutectoid composition will transform into coarsely lamellar pearlite, and once the transformation is complete, the structure will remain essentially unchanged down to room temperature. The fact that the free ferrite regains its magnetism on passing through the  $A_2$  or Curie transformation is of only incidental importance, because this transformation does not affect either the structure or the mechanical properties.

Because free ferrite was formed originally at the boundaries of the austenite grains, some estimate of the sizes of these grains can be made in the higher carbon hypoeutectoid alloys even though the austenite grains themselves are stable only above  $A_3$ .

Since the compositions of neither the ferrite nor the cementite change to any marked extent once they are formed, the lever rule can be used here, with particular advantage, to estimate the carbon content of steels from their metallographic structures. All that is required is that the specimen be in approximate equilibrium, i.e., slowly cooled from above the critical temperature range. For the 0.25% carbon alloy the constitution would be, by weight:

$$\% \text{ Proeutectoid ferrite} = 100 \times \frac{0.83 - 0.25}{0.83 - 0} = 70\%$$

$$\% \text{ Pearlite} = 100 \times \frac{0.25 - 0}{0.83 - 0} = 30\%$$

The metallographic structural constituents would be in nearly the same ratio because their specific volumes are nearly the same.

A cooling curve for this alloy can be rationalized readily on the basis of those given earlier for the simpler alloys. There will be a decreased rate of cooling during the solidification period, and during the separation of free ferrite between  $A_3$  and  $A_1$ ; and there will be a flat portion when the saturated austenite transforms to pearlite.

If this alloy is reheated, essentially the same changes will occur at nearly the same temperatures except in the reverse order. The pearlite will transform into austenite at about 1330 F (725 C); and, as the temperature increases up to  $A_3$ , the remaining proeutectoid ferrite will redissolve in this austenite. Above  $A_3$  the alloy will consist entirely of fairly homogeneous austenite grains until the temperature reaches the solidus line, when melting will begin.

These phase changes will repeat themselves on cooling or on heating as often as the alloy is carried through the cycle, as long as the composition does not change because of oxidation or other causes.

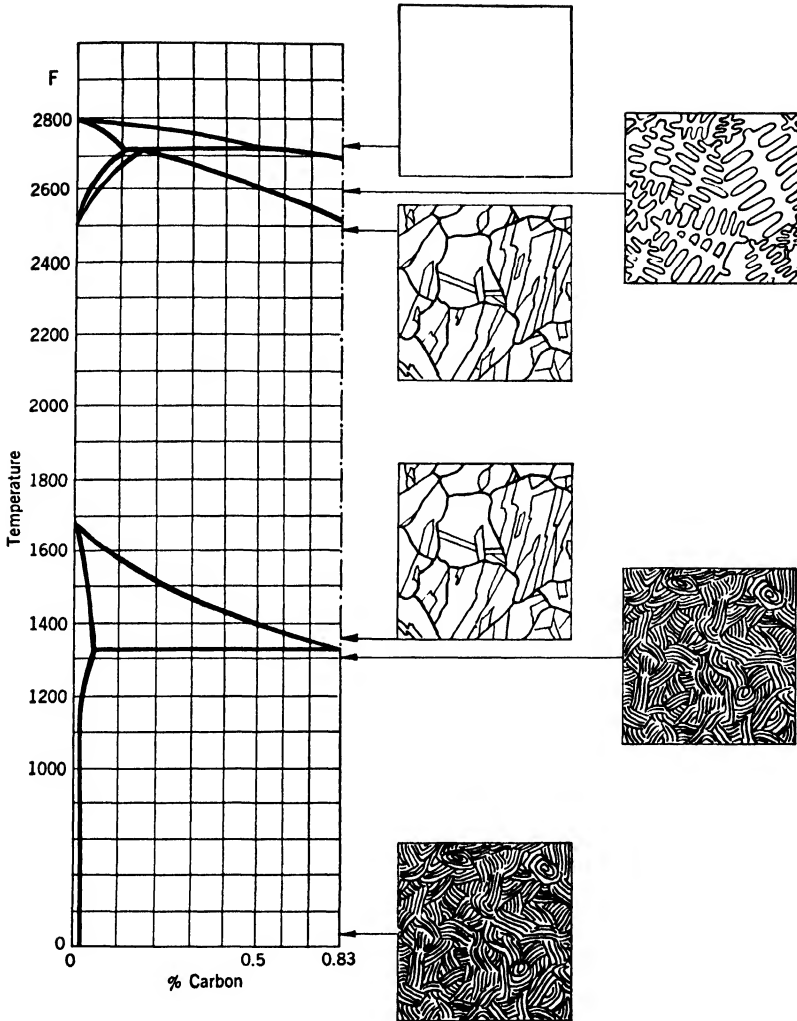


FIGURE 224. Schematic illustration of the structural changes in a 0.83% carbon tool steel as it cools slowly to room temperature from the liquid state.

STRUCTURAL CHANGES IN THE EUTECTOID ALLOY

Consider next a *tool steel* free from impurities and of approximately eutectoid composition, 0.83% carbon (Fig. 224). Immediately after solidification this steel, also, will be composed essentially of a homogeneous austenite which differs only in its carbon content from that formed in the constructional steel example. The structure at this temperature will be that of a typical austenite. On cooling, no change will take place in the structure, except possible further homogenization, until the  $A_{321}$  trans-



FIGURE 225. Metallographic structure of pearlite showing the relative thicknesses of the ferrite and cementite lamellae. Etched with saturated picral.  $\times 2500$ , originally, reduced somewhat in reproduction. (Photomicrograph courtesy U.S. Steel Corporation Research Laboratories, Kearny, N. J.)

formation begins at the eutectoid temperature. At this temperature, an alloy of eutectoid composition already is saturated with carbon, and, therefore, it will transform directly and completely, at an essentially constant temperature, into a coarsely pearlitic structure. The size of the pearlite nodules need not necessarily be the same as that of the austenite grains from which they were formed. Under some conditions the pearlite nodules will be larger, and under others they will be smaller than the austenite grains. Essentially no change takes place in the alloy as it cools from the  $A_{321}$  transformation down to room temperature.

The cooling curve for this alloy would show, in addition to the usual transformation on solidification from the liquid state, only one break, a flat portion at the  $A_{321}$  transformation.

On reheating, the same changes would occur except in the reverse order. The pearlitic alloy would be essentially unchanged up to the eutectoid temperature where, at a constant temperature, it would transform into an alloy which was 100% homogeneous austenite.

Although this eutectoid alloy at room temperature would be composed entirely of the constituent pearlite, it will be recalled that pearlite is composed of the two phases, ferrite and cementite. The relative percentages of these also can be computed according to the lever rule as illustrated below:

$$\% \text{ Ferrite} = 100 \times \frac{6.67 - 0.83}{6.67 - 0} = 87.5\%$$

$$\% \text{ Cementite} = 100 \times \frac{0.83 - 0}{6.67 - 0} = 12.5\%$$

Since both ferrite and cementite have nearly the same specific volumes (1/sp gr), in the micrograph taken at a high power (Fig. 225) the thicker lamellae in a given pearlite colony clearly will be the ferrite, and the thinner lamellae, the cementite.

#### STRUCTURAL CHANGES OCCURRING IN A HYPEREUTECTOID STEEL

Next consider a hypereutectoid *tool steel* containing about 1.25% carbon and free from impurities (Fig. 226). Although the solidification of this

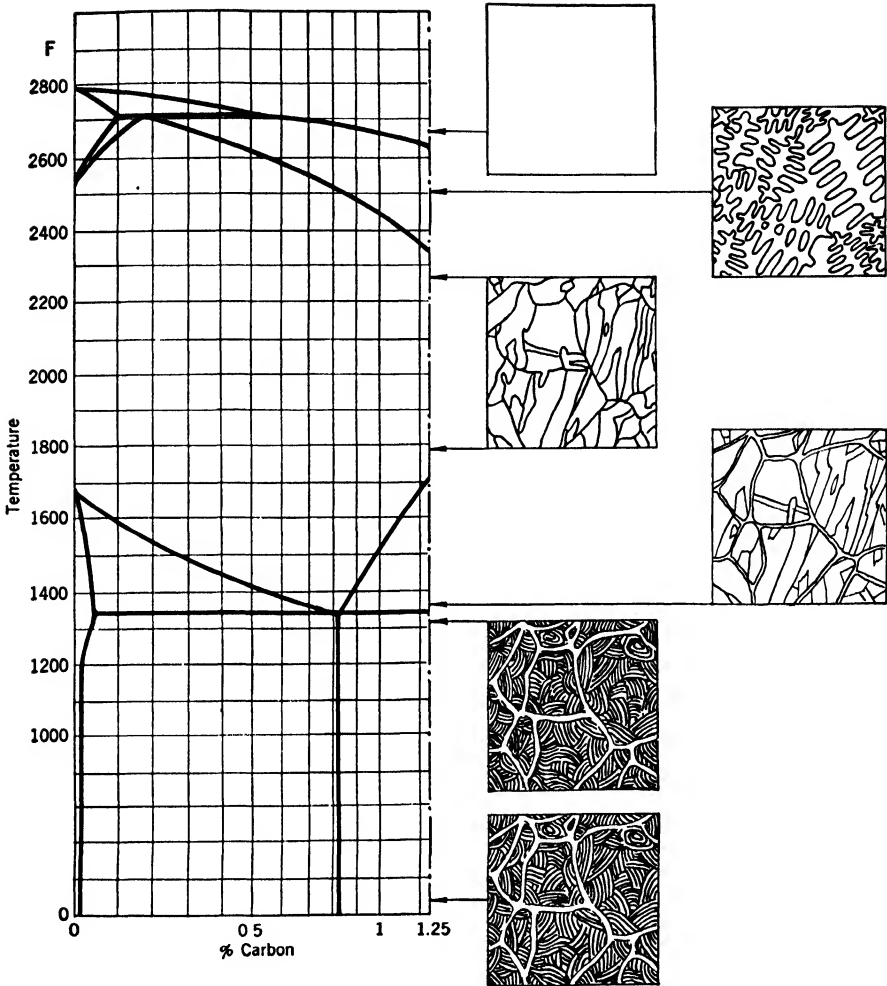


FIGURE 226. Schematic illustration of the structural changes in a 1.25% carbon tool steel as it cools slowly to room temperature from the liquid state.

alloy will not be complete until a temperature has been reached which is appreciably lower than for the two preceding examples, it, too, will solidify into an homogeneous austenite exactly as did the two steels of lower carbon content. This austenite will cool essentially unchanged until it reaches a temperature indicated by the line  $ES$  on the diagram in Fig. 222. This line, which is known as the  $A_{cm}$ , indicates the temperatures at which cementite starts to precipitate from the solid austenite. Using a terminology similar to that used for the hypoeutectoid steels, the austenite which is stable at temperatures below the  $A_{cm}$  line can retain in solid solution a smaller amount of carbon than that which is stable above this line. It therefore must dispose of its excess carbon, and it does so by precipitating

it as the compound  $\text{Fe}_3\text{C}$ , cementite, at the grain boundaries of the austenite grains. However, since there is so much less cementite precipitated for a given change in carbon content than there was free ferrite in the hypoeutectoid steels, the cementite envelopes around the austenite grains will be very much thinner than were the ferrite envelopes in the hypoeutectoid steels. The precipitation of excess carbon as cementite will continue until the  $A_{321}$  transformation is reached at 1330 F (725 C). At this temperature, the austenite contains about 0.83% carbon, which is the least that it can contain at this temperature and remain stable. It, therefore, will transform to pearlite on further cooling. The resulting structure will consist of pearlitic regions outlined by envelopes of free cementite.

In these alloys, also, since the cementite was formed at the grain boundaries of the former austenite grains, its distribution can be used as a measure of the austenite grain size which was stable before cooling started.

Application of the lever rule to the structure of this alloy indicates a structural distribution of either:

$$\% \text{ Pearlite} = 100 \times \frac{6.67 - 1.25}{6.67 - 0.83} = 92.8\%$$

$$\% \text{ Proeutectoid cementite} = 100 \times \frac{1.25 - 0.83}{6.67 - 0.83} = 7.2\%$$

or, considering the alloy to be composed of the phases ferrite and cementite,

$$\% \text{ Ferrite} = 100 \times \frac{6.67 - 1.25}{6.67 - 0} = 81.2\%$$

$$\% \text{ Cementite} = 100 \times \frac{1.25 - 0}{6.67 - 0} = 18.8\%$$

depending on the point of view that is taken. Metallographic structures of alloys in each of these conditions are shown in Fig. 227.

The cooling curve for an alloy of this composition would show two changes in addition to those occurring during solidification from the liquid state, a slight change of slope beginning at the temperature at which the alloy crosses the  $A_{cm}$  and a constant temperature or flat portion as the austenite transforms to pearlite at the eutectoid temperature,  $A_{321}$ .

On heating the alloy, the same changes would occur, except in reverse order as has been discussed previously.

#### PROPERTY CHANGES WITH PERCENTAGE CARBON IN SLOWLY COOLED STEELS

The properties of the slowly cooled steels also can be rationalized from their metallographic structures. Ferrite is relatively soft with an ultimate

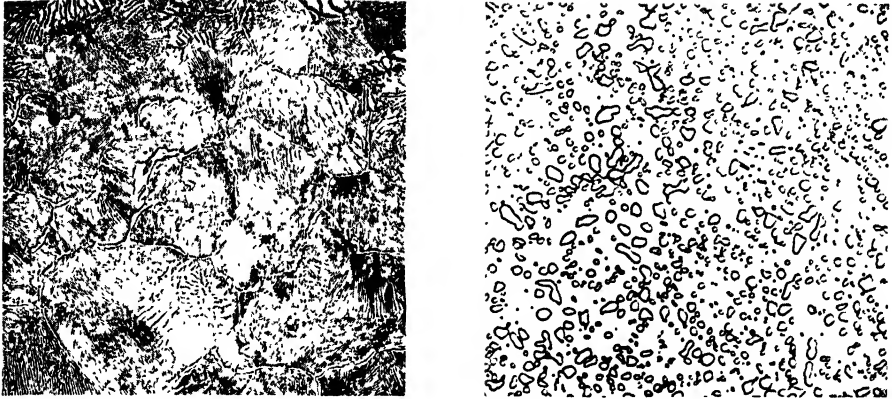


FIGURE 227. Metallographic structures of a 1.25% carbon steel.

*a. (Left)* Normalized, original austenite grains surrounded by envelopes of cementite and transformed to pearlite. Etched with picral.  $\times 250$ .

*b. (Right)* Spheroidized cementite, divorced spheroids in a matrix of ferrite. Etched with picral.  $\times 500$ . (Photomicrograph by M. C. Fetzer.)

strength of about 40,000 psi. The eutectoid, pearlite, is very much harder and stronger, its strength approximating 100,000 psi. The pearlitic structure is the strongest found in the slowly cooled alloys of iron and carbon. The compound, cementite, as would be expected, is quite hard and brittle; because of this its tensile strength is very difficult to determine. It usually is taken to be quite low, probably not exceeding about 5,000 psi. Actually it is probably higher, but it is so brittle and it has been studied to such a limited extent that little actually is known about it.

Since all of the carbon steels, basically, are mechanical mixtures of ferrite and cementite, their hardness<sup>14</sup> will increase as the percentage of iron carbide increases. The hardness for any annealed alloy (Fig. 228) will be only slightly greater than that which would be indicated by a straight-line relationship between the hardnesses of ferrite and cementite, even though the latter is so brittle its hardness cannot be determined readily.

The tensile strength is affected to a greater extent than the hardness by the manner of aggregation of the ferrite and cementite particles. The eutectoid alloy, therefore, since it is composed of the finest state of aggregation in the slowly cooled alloys, would be expected to have the strongest structure, and this generally is considered to be the case. The tensile strength will increase rapidly with the percentage of pearlite in the hypoeutectoid steels, reaching a maximum at about the eutectoid composition. The hypereutectoid steels are slightly stronger than the eutectoid composi-

<sup>14</sup> See F. T. Sisco, *Alloys of Iron and Carbon*, Vol. II, p. 83-85: McGraw-Hill Book Company, Inc., New York, 1937.

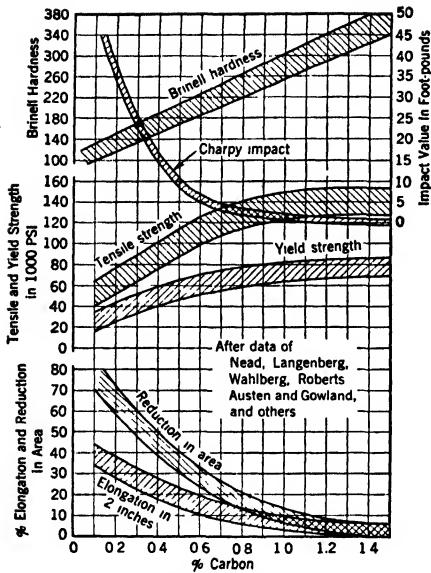


FIGURE 228. Effect of carbon content on mechanical properties of hot-worked steels. (After *Alloys of Iron and Carbon*, vol. II by F. T. Sisco: McGraw-Hill Book Company, Inc., New York.)

will they be. By assuming that the variations in tensile strength proceed according to straight line relationships, depending on the percentage of ferrite, pearlite, and cementite that are present, reasonably close approximations to the actual tensile strengths can be secured by simple arithmetic computation.<sup>15</sup>

#### EFFECT OF OTHER ALLOYING ELEMENTS UPON THE ALLOTROPIC TRANSFORMATION IN PURE IRON

When other elements are alloyed with iron, it will be found that their effects on the allotropic transformation fall into one of two classifications.<sup>16</sup> The effect of alloying elements falling in the first group is to *depress* the  $\alpha$ - $\gamma$  transformation and to *raise* the  $\gamma$ - $\delta$  transformation, thus widening the temperature range within which gamma iron is stable. Alloying elements falling in the second group tend to *raise* the  $\alpha$ - $\gamma$  transformation and to *depress* the  $\gamma$ - $\delta$  transformation, thus decreasing the temperature range within which gamma iron is stable. In each of the two classifications, there

<sup>15</sup> See, for example, Ref. 1 at end of this chapter; and F. M. Walters, Jr., *Trans. A.I.M.E.*, **154**, 1942, 407-412, if it is desired to base the computation on chemical composition rather than structure.

<sup>16</sup> See, for a further discussion, E. C. Bain, Ref. 5 at end of this chapter.

tion, largely because of the cementite envelopes around the pearlite areas, but the difference is not very great.

The most cold-workable alloy would be composed, of course, entirely of ferrite, and as the percentage of iron carbide is increased, the cold workability will decrease appreciably. The greatest brittleness is found after the eutectoid composition is exceeded, and excess iron carbide begins to appear as a constituent surrounding the pearlite nodules.

Thus, for slowly cooled carbon steels, the lower the carbon content, the softer, more workable, and weaker will the alloys be; and the higher the carbon content, the harder, stronger, and more brittle

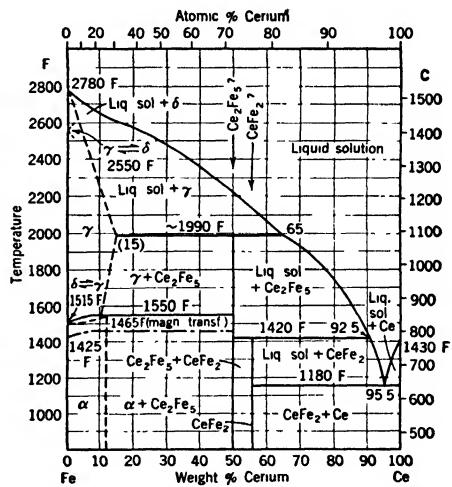
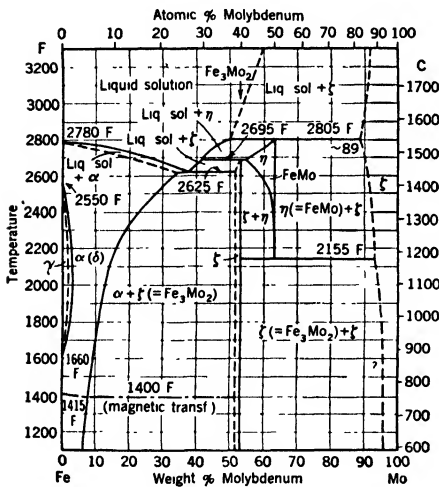
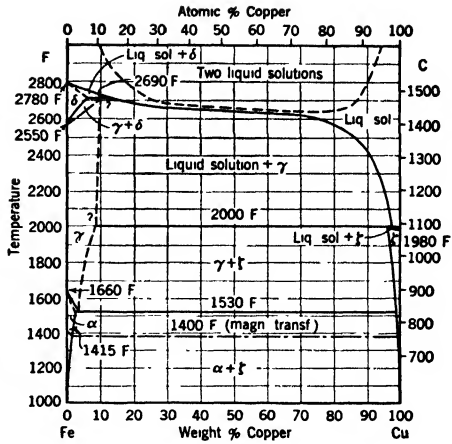
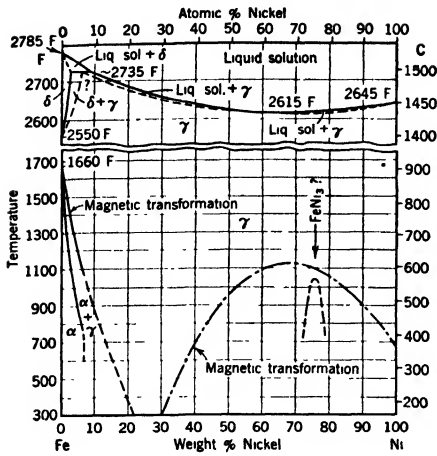


FIGURE 229a (Upper left) and b (Upper right). Constitutional diagrams typical of iron binary alloys in which the temperature range of stability of gamma iron is increased by alloying. (After F. Wever.)

a. Iron-nickel diagram, representative of elements which are soluble both in gamma and in alpha iron. (After M. Hansen.)

b. Iron-copper diagram, representative of elements which form either compounds or second phases, i.e., secondary or other primary solid solutions. (After M. Hansen.) The iron-iron carbide diagram, Fig. 215, is also of this type.

FIGURE 229c (Lower left) and d (Lower right). Constitutional diagrams typical of iron binary alloys in which the temperature range of stability of gamma iron is decreased by alloying. (After F. Wever.)

c. Iron-molybdenum diagram, representative of elements which are soluble both in gamma and in alpha iron. (After M. Hansen.)

d. Iron-cerium diagram representative of elements which form either compounds or second phases, i.e., secondary or other primary solid solutions. (After M. Hansen.)



are two subdivisions depending upon whether or not intermetallic compounds or solid solutions, rich in the alloying elements, are formed. In each case, of course, the iron-rich portion of the diagram is the most significant portion.

The alloying metals *manganese*, *nickel*, and *cobalt* increase the range of stability of gamma iron. These alloying elements are soluble in appreciable amounts in both the gamma and alpha irons. The iron-nickel diagram, which is typical for these metals, is illustrated in Fig. 229a.

The alloying elements *copper*, *zinc*, *gold*, *nitrogen*, and *carbon* also increase the temperature range of stability of gamma iron. However, with these alloying elements either compounds or solid solutions rich in the alloying elements tend to form, and the constitutional diagram, therefore, resembles that for iron-copper shown in Fig. 229b, as well as the iron-iron carbide diagram which has been discussed already.

The elements *silicon*, *chromium*, *tungsten*, *molybdenum*, *phosphorus*, *vanadium*, *titanium*, *beryllium*, *tin*, *antimony*, *arsenic*, and *aluminum* all tend to decrease the temperature range of stability of gamma iron, and tend to form what is known as a gamma loop, as illustrated by the iron-molybdenum diagram in Fig. 229c. All of these metals, in addition, form solid solutions of appreciable extent with body-centered iron, which may be considered to be either alpha- or delta iron, depending on the temperature range considered. From the diagram, it readily can be seen that the two merge and become identical once the gamma loop is closed.

The elements *tantalum*, *zirconium*, *boron*, *sulfur*, and *cerium* also decrease the temperature range of stability of gamma iron; but in each instance the diagram is complicated by the occurrence of compounds, as illustrated by the iron-cerium diagram in Fig. 229d.

#### THE EFFECTS OF CARBON UPON IRON BINARY ALLOYS

*Steels are alloys of iron and carbon.* Hence, when a third element is added to an alloy of iron and carbon, the resulting alloy may be considered from either of two viewpoints. The alloying element may be considered as being added to steel, in which case the important thing is its effect on the iron-carbon diagram; or else the carbon may be considered as being added to the iron binary alloy, in which case the important factor is the effect of carbon in modifying the iron binary alloy. The utility of either of these viewpoints depends upon the specific alloy concerned. In some cases one of them may be simpler to interpret than the other.

In Fig. 230 is shown the effects of the important alloying element, *manganese*, upon the limits of the austenite field in the iron-carbon dia-

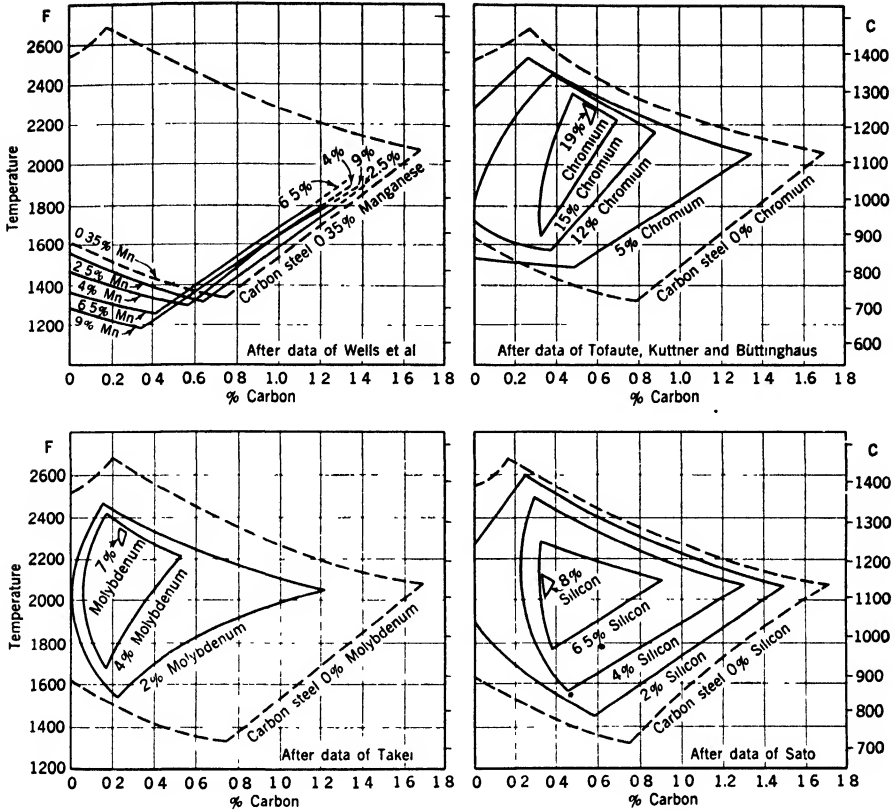


FIGURE 230. (Upper left) Effect of several uniform manganese contents upon the carbon limitations for pure austenite at elevated temperatures. (Courtesy E. C. Bain, Ref. 5 at the end of this chapter.)

FIGURE 231. Effects of several uniform chromium (upper right), molybdenum (lower left), and silicon (lower right) contents upon the carbon limitations for pure austenite at elevated temperatures. (Courtesy E. C. Bain, Ref. 5 at the end of this chapter.)

gram. Increasing percentages of manganese are seen to lower the eutectoid temperature, and to decrease the percentage of carbon in the eutectoid. This means that a fully pearlitic structure could be produced containing as little as about 0.3% carbon, if the proper manganese content were used.

In Fig. 231, the effects of the three alloying elements, *chromium*, *molybdenum*, and *silicon*, upon the limits of the austenite field on the iron-carbon diagram are illustrated. These three metals behave in a different manner from manganese, the addition of any one of them tending to decrease the extent of the austenite field instead of increasing it. This means that the addition of any of these alloying elements alone to a steel will tend to make

it ferritic, i.e., composed essentially of body-centered cubic iron, and the constituent austenite (face-centered cubic) will be stable only within a very restricted range of temperatures and compositions, depending upon the percentage of alloying element present. It will be noticed that in each of these examples also the percentage of carbon in the eutectoid decreases with increasing amounts of alloying element, as with manganese, but that here the temperature of the eutectoid inversion tends to increase with increasing amounts of alloying element rather than to decrease, as it did with manganese. Thus, for these three elements, a fully pearlitic structure also could be produced with appreciably less carbon, but the transformation would take place at a considerably higher temperature.

The ability of alloying elements to facilitate the production of a fully pearlitic structure with a comparatively low carbon content is important, since it will be remembered that the strongest alloy is the pearlitic alloy and that hardness and brittleness increase with the percentage of iron carbide present. Obviously if a strong, fully pearlitic structure can be produced in an alloy steel with a smaller percentage of carbon than in a plain carbon steel, less iron carbide will be present, and the structure will tend to be softer and less brittle, therefore, than a similar structure in a plain carbon steel.

The effects of different percentages of the important alloying elements upon the eutectoid temperature and upon the percentage of carbon in the eutectoid are summarized in Fig. 232. From these data it is seen that all of the alloying elements tend to decrease the percentage of carbon in the eutectoid, but that, of the seven shown, only *manganese* and *nickel* tend to decrease the eutectoid temperature.

#### EFFECTS OF CARBON UPON IRON BINARY ALLOYS

Where the alternate viewpoint, in which carbon is considered as added to an iron binary alloy, seems to be desirable, the result may be anticipated to a large extent by the information that already is available. First, gamma iron is known to dissolve appreciable amounts of carbon, whereas alpha iron is known to dissolve carbon only slightly, if at all. In either case, the carbon in excess of that held in solid solution generally appears as a carbide, either of iron or of iron plus the alloying element. Furthermore, it is known also that the addition of carbon to gamma iron tends to widen somewhat the temperature range within which gamma iron is stable, and produces an alloy phase, i.e., austenite, which will tend to decompose to a mixture of ferrite and carbide by an eutectoid inversion.

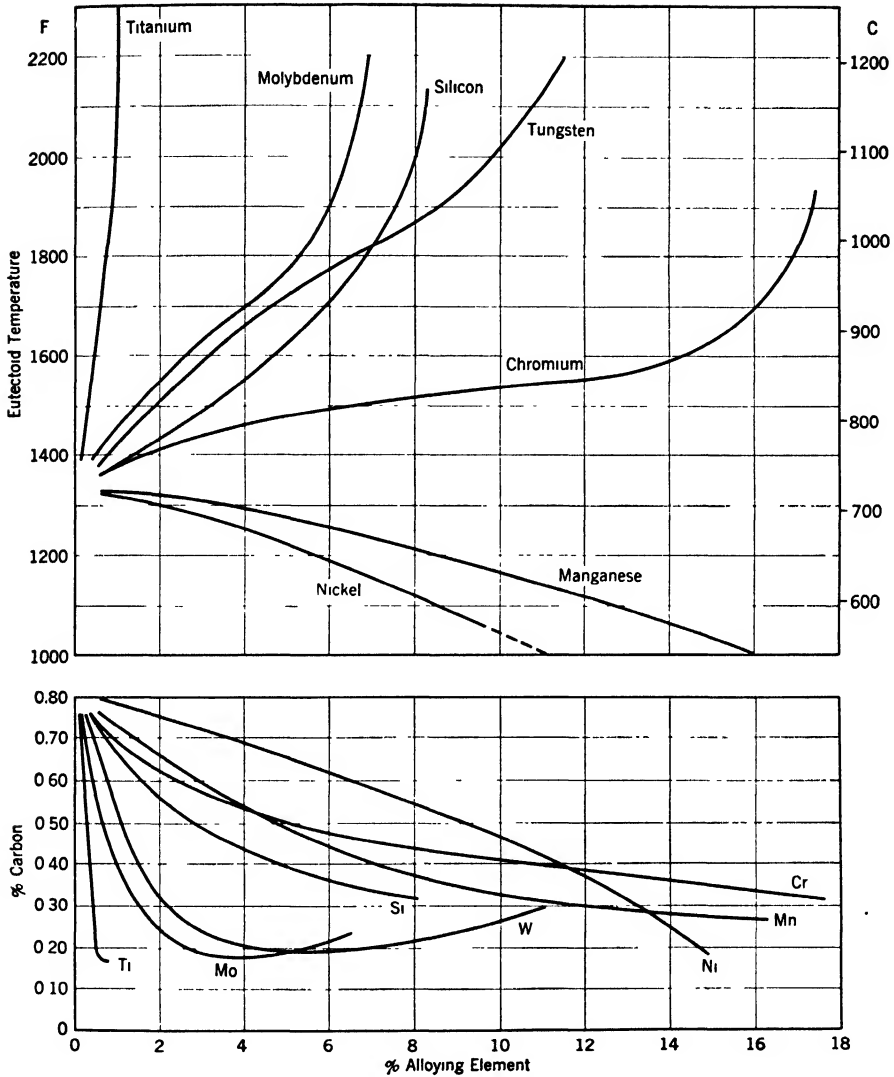


FIGURE 232. Eutectoid temperature and eutectoid composition as influenced by several alloying elements. (Courtesy E. C. Bain, Ref. 5 at the end of this chapter.)

It readily can be seen, therefore, that for those alloys which tend to widen the stable range of gamma iron, the presence of carbon in addition to the alloying element will assist in making austenite stable at a lower temperature. These alloy steels eventually will reach a composition at which the austenite is stable at room temperature and they then will be known as *austenitic steels*. In such alloys, the austenite can be made to decompose to ferrite and carbide in an eutectoid inversion only by cooling it to a

sufficiently low temperature, such as that of liquid air, for example; and in some alloys, even this is not possible. Such austenitic alloys are nearly always not susceptible to heat-treatment and thus differ from the plain carbon steels.

When the alloying element tends to result in the formation of a closed gamma loop, the added carbon can remain in solid solution only as long as the austenite remains stable. If the iron binary alloy is ferritic, then the carbon must appear as a carbide of some sort. The alloy steel then will be known as a *ferritic alloy steel*. If, by heating such a ferritic alloy steel, it can be brought into an austenitic range, then it is considered best as a steel since it will be susceptible to heat-treatment in the manner that will be discussed later. However, if such an alloy steel remains ferritic irrespective of the temperature to which it is heated, then it is considered best as an iron alloy instead of as an alloy steel since it will not be susceptible to heat-treatment.

#### ALLOY DISTRIBUTION IN HEATED STEELS

In general, the alloying elements in steel can exist only in one of four ways: (a) dissolved in austenite; (b) dissolved in ferrite; (c) combined as carbides; (d) combined as nonmetallic inclusions (usually, in alloy steels, this classification will include nitrides only). When the alloying element goes into solid solution, its effect upon properties will be similar to that found for any other solid solution, i.e., it will tend to increase the hardness and strength and to decrease the workability. However, these effects are relatively unimportant in comparison with the effects of the alloying elements upon the rate of transformation of austenite in the eutectoid inversion. These effects will be discussed in more detail later.

#### S. A. E. STEEL NUMBERING SYSTEM

Steels which conform to the standard specifications of the Society for Automotive Engineers are identified by a numeral index system. The American Iron and Steel Institute (A.I.S.I.) uses a similar numerical system and also indicates, by a letter prefix, the steelmaking process used. In the S. A. E. system the first digit indicates the type to which the steel belongs, thus 1- indicates a carbon steel; 2- a nickel steel; 3- a nickel-chromium steel; etc. The second digit generally indicates either the approximate percentage of the predominant alloying element in a simple alloy steel, or else a more or less definite relationship between the predominant alloying elements in a more complex alloy steel. The last two or three

digits indicate the average carbon content in points, i.e., 1 point = 0.01%. In addition the prefix "X" is used to indicate variations in the usually specified ranges of elements; and the prefix "T" is used with the 1300 series of manganese steels to designate steels of a somewhat different manganese range which otherwise are identified by the same numbers.

The basic S. A. E. types of steels<sup>17</sup> are:

---

Carbon steels	1xxx
Plain carbon	10xx
Free-cutting screw stock	11xx
Free-cutting manganese	X13xx
High manganese	T13xx
Nickel steels	2xxx
0.50% nickel	20xx
1.50% nickel	21xx
3.50% nickel	23xx
5.00% nickel	25xx
Nickel-chromium steels	3xxx
1.25% nickel-0.60% chromium	31xx
1.75% nickel-1.00% chromium	32xx
3.50% nickel-1.50% chromium	33xx
3.00% nickel-0.80% chromium	34xx
Corrosion- and heat-resisting steels	30xxx
Molybdenum steels	4xxx
Chromium-molybdenum	41xx
Chromium-nickel-molybdenum	43xx
Nickel-molybdenum	46xx and 48xx
Chromium steels	5xxx
Low chromium	51xx
Medium chromium	52xxx
Corrosion- and heat-resisting	51xxx
Chromium-vanadium steels	6xxx
Tungsten steels	7xxx and 7xxxx
Silicon-manganese steels	9xxx

---

More complete limits of chemical composition are given in the standards themselves to apply to the steels as furnished to the purchaser.

In addition to the standard S. A. E. analyses a number of National

<sup>17</sup> Ref. 16, at end of this chapter.

Emergency Steels were developed recently in order to conserve critical alloying elements by use of the principle that a greater effect is obtained by using a total of 1% of several alloying elements than by using 1% of any one alone. Some of these undoubtedly will continue in use although, as usual, the economics involved will be the deciding factor.<sup>18</sup> These so-called NE steels fall into five major groups: (a) NE 13xx, a group of carbon-manganese steels (1.6–1.9% Mn, 0.2–0.35% Si); (b) NE 86xx and 87xx nickel-chromium-molybdenum steels containing about 0.7–0.9% Mn, 0.2–0.35% Si, 0.4–0.6% Cr, 0.4–0.7% Ni, 0.15–0.25% Mo; (c) NE 92xx, silicon-manganese steels (1.8–2.2% Si, 0.7–1.0% Mn) some members of which also contain up to 0.4% chromium; (d) NE 94xx and 95xx, manganese-nickel-chromium-molybdenum steels containing approximately 0.8–1.5% Mn, 0.2–0.6% Si, 0.3–0.6% Cr, 0.3–0.7% Ni, 0.08–0.25% Mo, the 94xx group falling near the low side and the 95xx group near the high side of the ranges shown; and (e) NE 52100, carbon-chromium steels containing varying amounts of chromium in the range 0.4–1.6%.

#### THE STABLE IRON-GRAPHITE DIAGRAM

It has been known for many years that the cementite in white cast iron could be decomposed, and careful study has shown that steels composed of the constituents ferrite and cementite are not entirely stable either, although their rate of decomposition is extremely slow under normal conditions. In other words, the iron-iron carbide diagram is only a *metastable* diagram, and the *stable* diagram is the one between iron and graphite.<sup>19</sup> The relationship between these two components is expressed by a different diagram, shown superimposed on the iron-iron carbide diagram in Fig. 233. The exact significance of this double diagram is not as yet entirely understood, although it is known that both the *malleable cast irons* and the *graphitic steels*, in which cementite does not appear as a separate constituent, can be produced by the use of certain heat-treatments or certain alloying elements in the proper amounts.<sup>20</sup>

In certain of the cast irons, both cementite and graphite do appear as apparently stable constituents in addition to ferrite. However, in these alloys the percentage of impurities is so high that the usual constitutional diagrams are of little assistance since they are, in reality, much more com-

<sup>18</sup> See, for example, the survey by E. F. Cone, *Metals and Alloys*, May, 1944.

<sup>19</sup> See, for example, *The Alloys of Iron and Carbon*, Vol. I, Chap. V: McGraw-Hill Book Company, Inc., New York, 1936.

<sup>20</sup> See, for example, F. R. Bonte and M. Fleischman, *Metal Progress*, 31, 1937, 409–413; also C. R. Austin and B. S. Norris, *Trans. A.S.M.*, 26, 1938, the first of a series of papers by C. R. Austin and his co-workers.

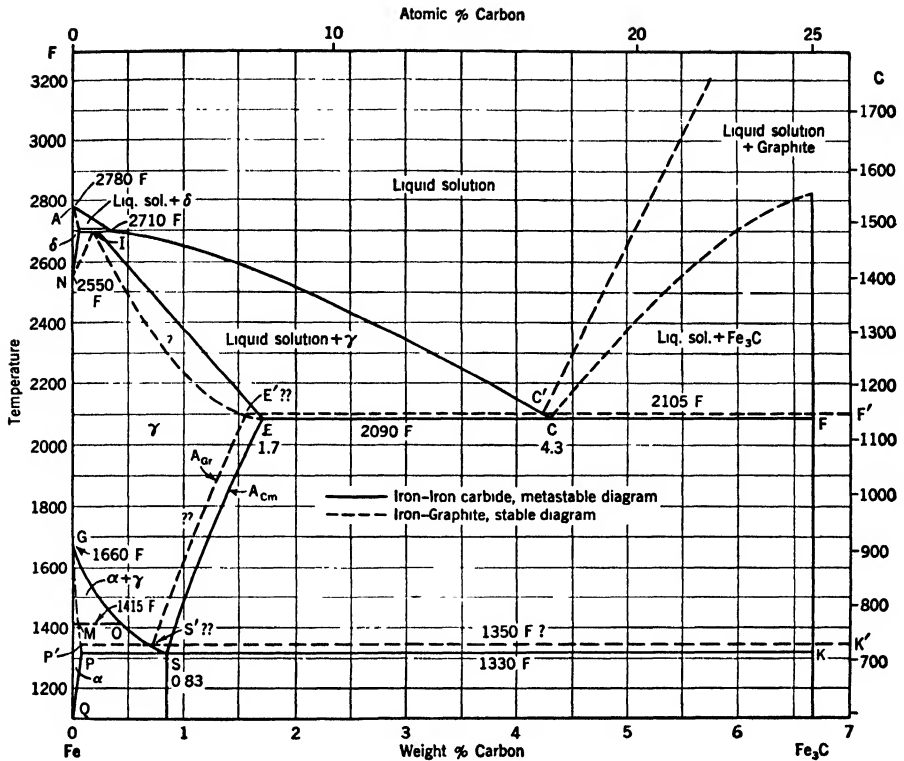


FIGURE 233. Constitutional diagram for the stable alloys of iron and graphite and for the metastable alloys of iron and iron carbide superimposed. (After M. Hansen.)

plex alloys than would be expected. It is, therefore, very difficult, if not impossible, to explain the structures found in most of the cast irons on the basis of the simple iron-carbon diagram.

GRAY CAST IRON

Gray iron, metallographically,<sup>21</sup> is a mixture of four or five constituents:

1. The essential *flake graphite* which is formed during solidification and which to a large extent determines the properties of the casting by its amount, size, shape, and distribution. Various forms of graphite flakes, some typical examples of which are illustrated in Fig. 234, are classified in A.S.T.M. Tentative Standard A247-T.
2. *Pearlite* is the usual second constituent. Because of the alloy content of the iron it may vary in composition between about 0.50 and 0.90% carbon.

<sup>21</sup> See also R. M. Allen, *Microscope in Elementary Cast Iron Metallurgy*: American Foundrymen's Association, Chicago, Ill., 1939.



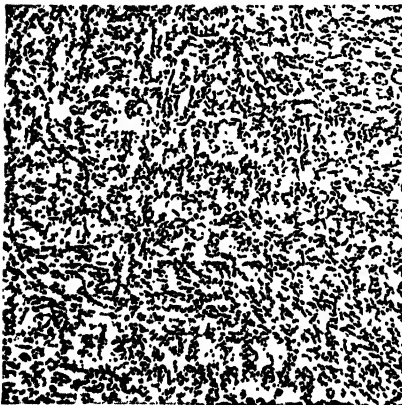
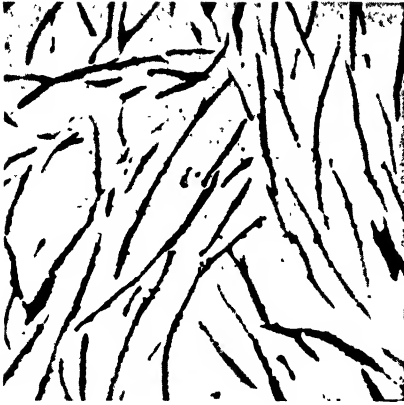


FIGURE 234. Metallographic appearance of various forms of graphite found in gray cast irons. Unetched.  $\times 50$ . These correspond approximately to the following sizes in A.S.T.M. Tentative Standard A247-T: (Top left) Size 2, longest flake 1-2 in. in length ( $\times 50$ ). (Top right) Size 3, longest flake  $\frac{1}{2}$ -1 in. in length ( $\times 50$ ). (Middle left) Size 4, longest flake  $\frac{1}{4}$ - $\frac{1}{2}$  in. in length ( $\times 50$ ). (Middle right) Size 5, longest flake  $\frac{1}{8}$ - $\frac{1}{4}$  in. in length ( $\times 50$ ). (Bottom left) Size 7, longest flake  $\frac{1}{32}$ - $\frac{1}{16}$  in. in length ( $\times 50$ ). The A.S.T.M. Tentative Standard also includes sizes 1, 6, and 8.

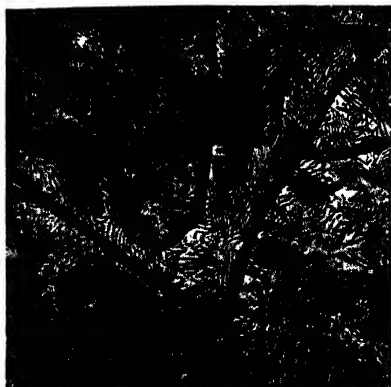


FIGURE 235. (Left) Metallographic appearance of *steadite* (light speckled regions) in gray cast iron. Etched with nital.  $\times 500$ . Reduced about one third in reproduction. (Photomicrograph courtesy United States Pipe and Foundry Co.)

FIGURE 236. (Right) Metallographic appearance of free ferrite (white) in gray cast iron. Etched with nital.  $\times 500$ . Reduced about one third in reproduction. (Photomicrograph courtesy United States Pipe and Foundry Co.)

3. Steadite, a hard brittle eutectic of iron and iron phosphide ( $\text{Fe}_3\text{P}$ ) and possibly containing some cementite also, always can be found when much phosphorus is present. Steadite contains about 10% phosphorus; and, therefore, a cast iron containing 1% phosphorus will contain about 10% steadite since very little if any phosphorus is found in other forms. This constituent melts at the comparatively low temperature of 1750–1850 F (950–1010 C), and hence usually is found at the edges of the large grains formed on solidification. Its structure is shown in Fig. 235. The fine speckled structure inside the particles is characteristic.
4. Free ferrite may appear, but usually only in appreciable amounts in low-strength cast irons. Since ferrite etches white with nital it sometimes is difficult to differentiate it from the steadite and cementite. However, the ferrite usually is more rounded in appearance than either the steadite or the cementite, because it precipitates from the solid solution (austenite) rather than solidifying directly from liquid solution, and frequently, in addition, is found in close association with graphite flakes, as in Fig. 236.
5. Free cementite is found, as a rule, only in white or mottled irons. It should not be confused with the light etching steadite which has a distinct fine structure because of its eutectic nature.

The general structural constituents of gray cast iron are shown in Fig. 237 at a somewhat lower power than used previously. Alloy castings also

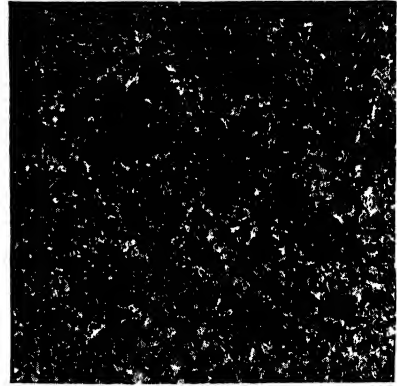
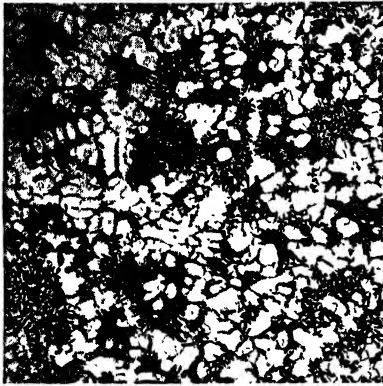


FIGURE 237. Metallographic appearance of general structural constituents of gray cast iron. Etched with nital.  $\times 100$ . Reduced about one quarter in reproduction.

a. (*Upper left*) Low-strength centrifugal casting, as cast, containing large amounts of free ferrite (3.40% T.C. — 1.90% Si — 0.50% Mn — 0.50% P — 0.07% S — rem. Fe).

b. (*Upper right*) Normal sand casting, as cast (3.78% T. C. — 0.67% C.C. — 1.09% Si — 0.38% Mn — 0.43% P — 0.064% S — rem. Fe).

(Photomicrographs courtesy United States Pipe and Foundry Company.)

FIGURE 238. (*Lower left*) Metallographic appearance of white cast iron. Etched with nital.

$\times 250$ . Cf. Fig. 497. The dark regions are pearlitic. The light regions are probably free cementite and the gray regions transformed ledeburite.

may be austenitic or contain specific complex constituents in addition to those mentioned above.

#### WHITE CAST IRON

The structures of unalloyed white cast iron are by no means easy to rationalize despite their apparent simplicity. Essentially, however, they all are composed of two important constituents:

1. *Cementite*, the constituent largely responsible for the brittleness, is present either in the free form or as a modified form of the eutectic, *ledeburite*. Which form occurs is determined largely by the carbon and alloy content.
2. *Pearlite* is present because some austenite always will be formed on solidification, and this transforms to pearlite on slow cooling through the critical range. If the cooling rate is increased, other constituents may be formed as explained in the next chapter.

Many structures can be rationalized on the basis of the simple iron-iron carbide diagram, but this is not always possible. A typical white iron structure is shown in Fig. 238. The large grains and cored structure typical of most castings can be seen readily although they are apt to be somewhat confused because of the general nature of the structure.

#### LIMITATIONS IN THE USE OF PHASE DIAGRAMS

The phase relationships shown in equilibrium diagrams are valid strictly only when pure components are used and when equilibrium conditions obtain at all times. To the engineer, it should be clear by this time that these conditions almost never are achieved in industrial alloying. The validity of the relatively simple binary or ternary diagrams for the interpretation of the metallographic structures found in industrial alloys might be questioned, therefore. From a purely scientific viewpoint, of course, they would not be of much value. However, the engineer generally is interested much more in trends than he is in exact scientific data. The simple diagrams, when properly and intelligently used, will enable him to predict what might be expected in alloys approximately corresponding to the compositions shown on the diagram.

The specific conditions required to produce a given set of properties almost never can be arrived at without a certain amount of preliminary experimentation. The greater the familiarity of the engineer with the metallic materials, the more will he realize the truth of this statement. The constitutional diagrams, therefore, will enable him to find an approximate starting point and thus to keep the required experimental work to a minimum.

#### *For Further Study Refer to*

1. *The Metallography and Heat Treatment of Iron and Steel*, 4th ed., by A. Sauveur: University Press, Cambridge, Mass., 1935.
2. *Metals Handbook*: American Society for Metals, Cleveland, Ohio, 1939 (usually published triennially). A new edition will appear in 1948.
3. *Principles of Phase Diagrams*, by J. S. Marsh: McGraw-Hill Book Company, Inc., New York, 1935.
4. *The Principles of Physical Metallurgy*, 2d ed., by G. E. Doan and E. H. Mahla: McGraw-Hill Book Company, Inc., New York, 1941.
5. *The Alloying Elements in Steel*, by E. C. Bain: American Society for Metals, Cleveland, Ohio, 1939.

6. *Metals*, by Sir Harold Carpenter and J. M. Robertson: Oxford University Press, London and New York, 1939.
7. *Constitution of Steel and Cast Iron*, by F. T. Sisco: American Society for Metals, Cleveland, Ohio, 1930.
8. *Practical Metallurgy*, by G. Sachs and K. R. Van Horn: American Society for Metals, Cleveland, Ohio, 1940.
9. *Principles of Metallography*, 4th ed., by R. S. Williams and V. O. Homberg: McGraw-Hill Book Company, Inc., New York, 1939.
10. *Powder Metallurgy*, edited by John Wulff: American Society for Metals, Cleveland, Ohio, 1942.
11. *Principles of Powder Metallurgy*, by W. D. Jones: Longmans, Green and Company, New York, 1937.
12. *Structure of Steel*, by E. N. Simons and E. Gregory: Prentice-Hall, Inc., New York, 1938.
13. *Metallography*, by C. H. Desch: Longmans, Green and Company, New York, 1937.
14. *Practical Microscopical Metallurgy*, by R. H. Greaves and H. Wrighton: D. Van Nostrand Company, Inc., New York, 1940.
15. *Ferrous Metallurgy*, by E. J. Teichert: McGraw-Hill Book Company, Inc., New York, 1944.
16. *S.A.E. Handbook*: Society for Automotive Engineers, New York (usually published annually).

## PURPOSES OF HEAT-TREATMENT

THE METALLIC MATERIALS ARE HEAT-TREATED EITHER TO remove, or balance, internal stresses or to produce certain characteristics which cannot so conveniently be obtained by other means. Depending upon the specific alloy and the treatment used, any of the chemical, mechanical, or physical characteristics may be affected. Since these changes in characteristics and properties are usually related to definite metallographic structures, the viewpoint might logically be taken that the main purpose of heat-treatment is to produce a definite structure in the metallic material. Frequently, however, the most significant structures are too fine to be resolved by the usual metallographic methods, and, hence, are apt to be somewhat controversial. Because of this, it is usually preferable to adopt a combination of the property and structural viewpoints in any discussion involving principles of heat-treatment.

## ENERGY INTENSITIES INVOLVED IN HEAT-TREATMENT

To produce any structural changes in a solid metal requires a certain atomic mobility or intensity of energy. This mobility is sometimes secured by mechanical deformation, but more often by the application of heat. For any specified temperature of heat-treatment, any given reaction will proceed at a more or less definite rate, because the atoms involved will have only a limited range of mobility. In addition, since these reactions may take place at a variety of temperatures as well as either on heating or on cooling, it is necessary to consider the *reaction tendency* or the *driving force*, as well as the reaction rate.

The greater the displacement from equilibrium conditions, the greater will be the reaction tendency. Thus, if the reaction tends to occur on heating, the higher the temperature to which the material is heated, the greater will be this tendency, and the faster the rate at which it will proceed, always provided, of course, that the temperature at which the reaction

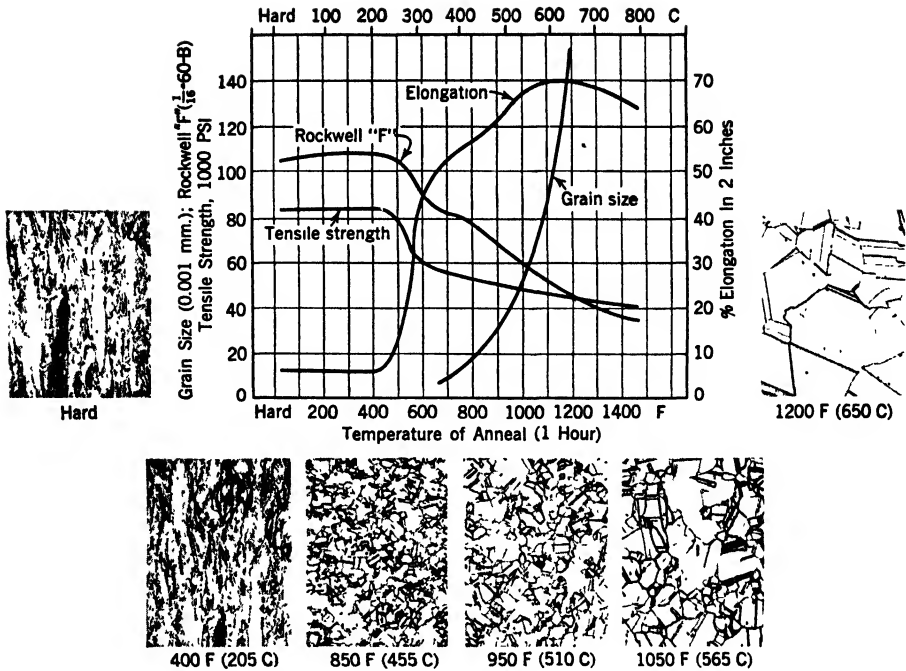


FIGURE 239. Progress of recrystallization in the annealing of cold-worked cartridge brass (70% Cu - 30% Zn) showing the changes that occur in both properties and metallographic structure. Etched with  $\text{NH}_4\text{OH} + \text{H}_2\text{O}_2$ .  $\times 75$ . Cf. Fig. 63.

would occur under equilibrium conditions is exceeded. Also, if the reaction tends to occur on cooling, the greater the amount of supercooling, or cooling below the temperature at which the reaction would take place under equilibrium conditions, the greater will be the reaction tendency, although the reaction rate will probably depend on several factors in addition to the actual temperature. Some of these factors have already been mentioned in Chap. II for the cases of solidification and strain recrystallization in pure metals.

The process of recrystallization<sup>1</sup> is a reaction which also occurs in solid alloys and under conditions which are quite similar to those discussed previously for the pure metals. This is illustrated in Fig. 239 for cartridge brass, 70% Cu - 30% Zn. It will be noted that here, as for the metal copper discussed earlier, no essential change in properties or structure occurs as the metal is heated to the lowest temperature of recrystallization. However, once this minimum temperature is exceeded, the ductility and workability tend to increase, and the tensile strength and hardness tend to decrease

<sup>1</sup> For a further discussion, see R. F. Mehl, *Metal Progress*, Feb. 1939, 156; *Metals Handbook*, 1939 ed., Amer. Soc. for Metals, Cleveland, Ohio, 207-213.

rapidly until they attain the values found in fully annealed material. Simultaneously, the metallographic structure will change, the severely strained and deformed crystals of the cold-worked alloy being replaced by the recrystallized, unstrained structure of the annealed aggregate.

#### STRESS RELIEF

As for a pure metal, any internal stresses existing in the aggregate because of unequal cooling, mechanical treatment, or other reasons will be relieved at temperatures below those tending to produce recrystallization.<sup>2</sup> Although a stress-relief treatment will have no effect on the metallographic structure of the material, and will have little noticeable effect on the mechanical properties except for increasing the yield strength, it will result in an appreciably better engineering material because of the increased factor of safety that it produces. Quite probably the internal stresses are really balanced rather than relieved completely, but here, too, it is the result that is important rather than the direct mechanism involved.

Any engineering structure is designed to withstand a certain type and magnitude of stress. If, because of the methods of fabrication, treatment, or construction, internal stresses of appreciable magnitude remain in the structure, its effectiveness may be considerably changed, e.g., either reduced or increased from that for which it was originally designed. This is especially significant when the internal stresses are not uniformly distributed; and, therefore, are more likely to lead to overloading in one particular portion of the structure. It is this possible concentration of stresses that may become dangerous rather than the actual presence of the internal stresses, because any engineering structure in use will contain some of the latter even though they may not attain a magnitude that is harmful.<sup>3</sup>

Artificially produced internal stresses may, in fact, be of great value if they can be distributed uniformly and be properly controlled, both in magnitude and in direction, i.e., either tensile or compressive. Thus, in the production of certain structures, such as large guns, car wheels, etc., outer layers have been shrunk on, thus producing a uniformly distributed compressive stress in the inner layers. This is the process known as *autofrettage*, which can also be applied by expanding an inner section, by hydraulic means, against an outer one.<sup>4</sup> Any bursting force acting from

<sup>2</sup> See C. S. Barrett, *Metals and Alloys*, 5, 1934, 131-135, 154-159, 170-174, 196-198, 224-226; also various publications of the Society for Experimental Stress Analysis, Cambridge, Mass.

<sup>3</sup> For a complete discussion of residual stresses, see Chap. VI of Ref. 11 at the end of this chapter.

<sup>4</sup> See, for example, N. E. Woldman, *Trans. A.S.M.*, 25, 1937, 206-228.



the inside of this inner layer must then overcome not only the compressive force, superimposed by the shrinkage or the expansion, but also the yield strength, and ultimate strength of the material itself before failure can occur. Usually this advantageous use of internal stresses can only be employed if very symmetrical structures are involved. It is noteworthy that a markedly greater fatigue strength invariably results when the residual stress in the most highly stressed portions is compressive in nature and that a residual tensile stress in these regions tends to have the reverse effect.

#### THE TIME FACTOR

The effectiveness of any reaction is determined by the amount that it proceeds toward completion. This involves not only the rate, which depends upon the temperature, but also the time for which it can proceed.<sup>5</sup> Reactions occurring within the solid state are frequently slow enough that the times required to produce definite changes in properties attain an appreciable magnitude, viz., minutes or hours rather than seconds. Furthermore, since the rate of reaction can be controlled readily by changing the temperature, it is frequently advisable to select a temperature for heat-treatment for which the time factor can be controlled easily. The reaction, then, can be stopped at any convenient time, and the properties resulting from that reaction can be limited to any desired proportion of the possible maximum.

#### TYPES OF REACTIONS CONTROLLABLE BY HEAT-TREATMENT

Three general types of reactions are of importance commercially, and form the basis for most heat-treating operations. The first is the *aging or precipitation reaction*, occurring when the solubility of a given constituent in the solvent material is greater at one temperature than it is at a lower one. The second is the *allotropic transformation reaction* which has already been described for the pure metal iron, and serves as the basis for most of the reactions in the steels. The third is the *decomposition reaction*, involving the decomposition of certain constituents into one or more others possessing more desirable properties. Reactions of this sort are of importance in the case of malleable cast iron and the so-called graphitic steels, for example, and certain other cast materials in which a second phase results from the decomposition of one formed originally either during solidification or during an earlier stage of a reaction in the solid state.

<sup>5</sup> See John Johnston, *Trans. A.I.M.E.*, **150**, 1942, 1-29.

## THE EFFECTS OF INTERNAL SURFACES

Little is known concerning the quantitative effects of internal surfaces upon reactions in the solid state.<sup>6</sup> However, qualitatively, it is known that such things as grain boundaries, slip lines, mechanical twins and deformation bands, the edges of annealing twin bands, and the surfaces of particles of a second phase seem to be particularly effective in serving as loci for nucleus formation and, thus, for initiating the reaction.

## AGE-HARDENING

The process of *age-* or *precipitation hardening*<sup>7</sup> is the only one, with the exception of mechanical deformation, by which the strength properties of most nonferrous alloys can be materially increased in a controllable manner. It is especially useful, therefore, in all cases where fabricated materials are used, whether these be cast or mechanically formed. Under such conditions, by selection of the proper alloy and the proper heat-treatment, it is possible to maintain the metal in a comparatively soft condition while the fabrication is carried out, and then to harden and strengthen it by heat-treatment at such a temperature that the other properties of the material will not be too greatly impaired.

## CONSTITUTIONAL DIAGRAMS OF BINARY ALLOYS SUSCEPTIBLE TO AGE-HARDENING

Since the susceptibility of an alloy to age-hardening is determined by the manner in which its component metals combine rather than by the dominant metal, alloys of a tremendous range of characteristics are opened up for improvements in the strength properties which are usually of the greatest interest to engineers. Alloys can be found of almost any density, any ductility, and any electrical or magnetic properties which can have their strengths improved without appreciable impairment of their other characteristics.

For susceptibility to age-hardening, it is important that the solute metals be soluble to a greater extent at a high temperature than they are at a lower temperature, as indicated in Fig. 240. This effect has already been illustrated for the alloys of silver and copper, in which a partial solid solubility exists. In Figs. 241 and 242 are shown constitutional diagrams for the

<sup>6</sup> See, for example, R. S. Dean and C. Y. Clayton, *Trans. A.S.M.*, 26, 1938, 237-251.

<sup>7</sup> See P. D. Merica, *Metal Progress*, 1935; Jan., p. 31; March, p. 46; June, p. 29; July, p. 41; also Ref. 13 at the end of this chapter.

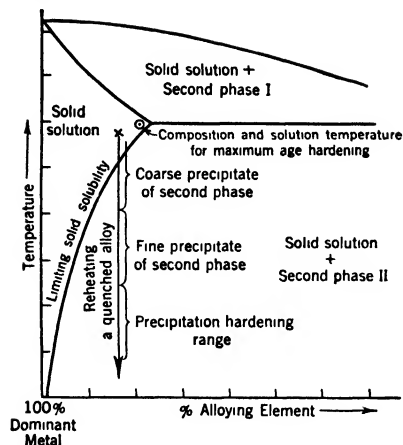


FIGURE 240. (Left) General form of constitutional diagram found for alloys which might be susceptible to age- or precipitation-hardening. The essential feature is, the precipitation of a second phase from solid solution on cooling (or reheating a quenched alloy). Whether or not hardening occurs depends on the manner in which this precipitation takes place.

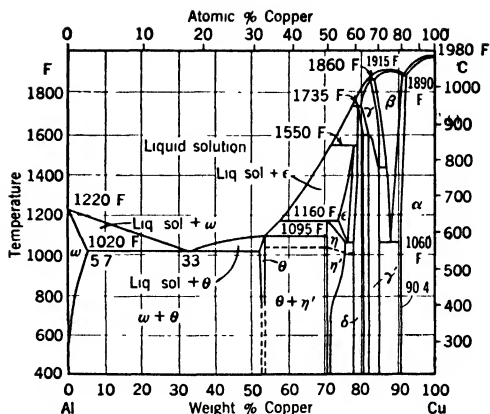


FIGURE 241. (Right) Constitutional diagram for the alloys of aluminum and copper: the duralumin-type alloys. (After M. Hansen.)

aluminum-rich alloys of aluminum and copper,<sup>8</sup> and the copper-rich alloys of copper and beryllium,<sup>9</sup> both of which are susceptible to this treatment. The magnitude of both the solubility and the change in solubility is of some importance, but it is not primarily responsible for the effect. For example, in Fig. 243 is shown the diagram for the alloys of iron and carbon in the range of solubility of carbon in alpha ferrite. It will be recalled that, in the discussion of the iron-carbon diagram, alloys within this range were merely classed as commercially pure ferrite, and given no further attention. It will be shown later that even in an alloy of this limited percentage of carbon, appreciable changes in properties are possible with the proper heat-treatment.<sup>10</sup>

#### HEAT-TREATMENTS REQUIRED FOR AGE-HARDENING

In the above constitutional diagrams an alloy heated to any temperature within the primary solid solution field will be composed, under equilibrium conditions, of a uniform solid solution rich in the dominant metal. If this alloy is slowly cooled to room temperature, a second phase, which

<sup>8</sup> See, for example, H. Y. Hunsicker, A.S.M. Preprint No. 12, 1939; Ref. 13, at the end of this chapter.

<sup>9</sup> See, for example, J. K. Smith, *Trans. A.I.M.E.*, **99**, 1932, 65-77.

<sup>10</sup> See, for a complete discussion, R. L. Kenyon and R. S. Burns, Ref. 13 at the end of this chapter.

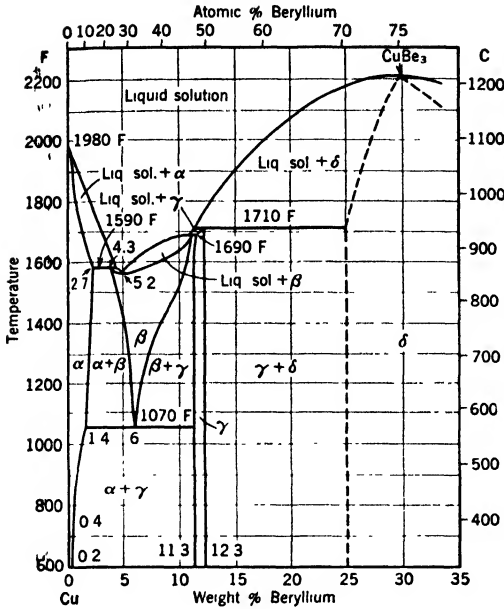


FIGURE 242. (Left) Constitutional diagram for the alloys of copper with up to 35% beryllium: the beryllium bronzes. (After M. Hansen.)

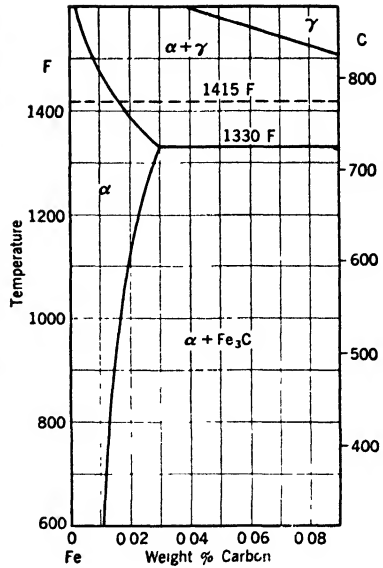


FIGURE 243. (Right) Constitutional diagram for the alloys of carbon and alpha ferrite: the deep-drawing steels. (After J. H. Whiteley.)

may be a compound, a secondary solid solution, another primary solid solution, or a commercially pure metal, will begin to precipitate, when the solid solubility line is crossed, because of the decrease in solubility of the solute metal as the temperature falls. After slow cooling, this would result in a structure similar to those shown in Fig. 244, depending on the exact manner in which precipitation occurred. However, if the rate of cooling is increased, it will be found that a rate can be secured for which no apparent change in structure occurs, and the solid solution can be retained at room temperature in a form which, although it is not stable, shows little tendency to precipitate the second phase because of the low intensity of energy available. The length of time that this condition exists depends upon the alloy concerned. In the case of a copper-beryllium alloy, for instance, the quenched material can apparently be retained almost indefinitely at room temperature without any sign of decomposition, either in properties or in structure. However, some of the aluminum alloys will tend to change after a comparatively short time at room temperature, as will be shown later. With any alloy of this type the change can be completely prevented by cooling rapidly enough to a sufficiently low temperature, and holding at that temperature.

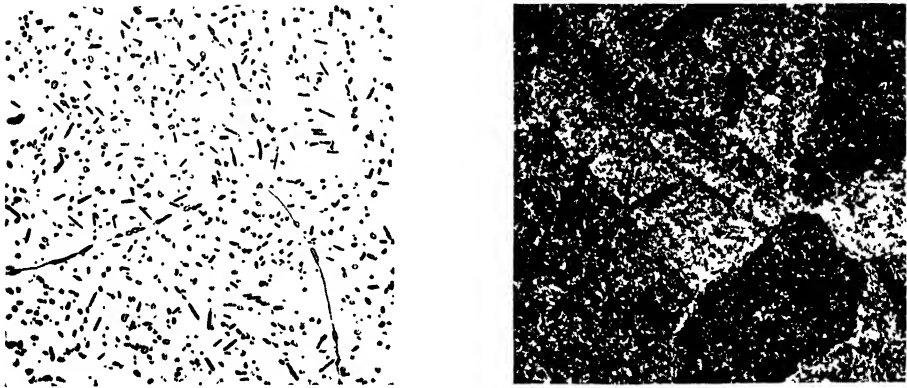


FIGURE 244. Metallographic structures of precipitation-hardenable alloys showing coarse particles of a second phase precipitated during slow cooling from the primary solid solution field.

*a. (Left)* Duralumin-type alloy. Etched with 1.2% HF.  $\times 100$ . (Photomicrograph courtesy Aluminum Research Laboratories.)

*b. (Right)* Beryllium bronze. Etched with  $\text{NH}_4\text{OH} + \text{H}_2\text{O}_2$ .  $\times 300$ .

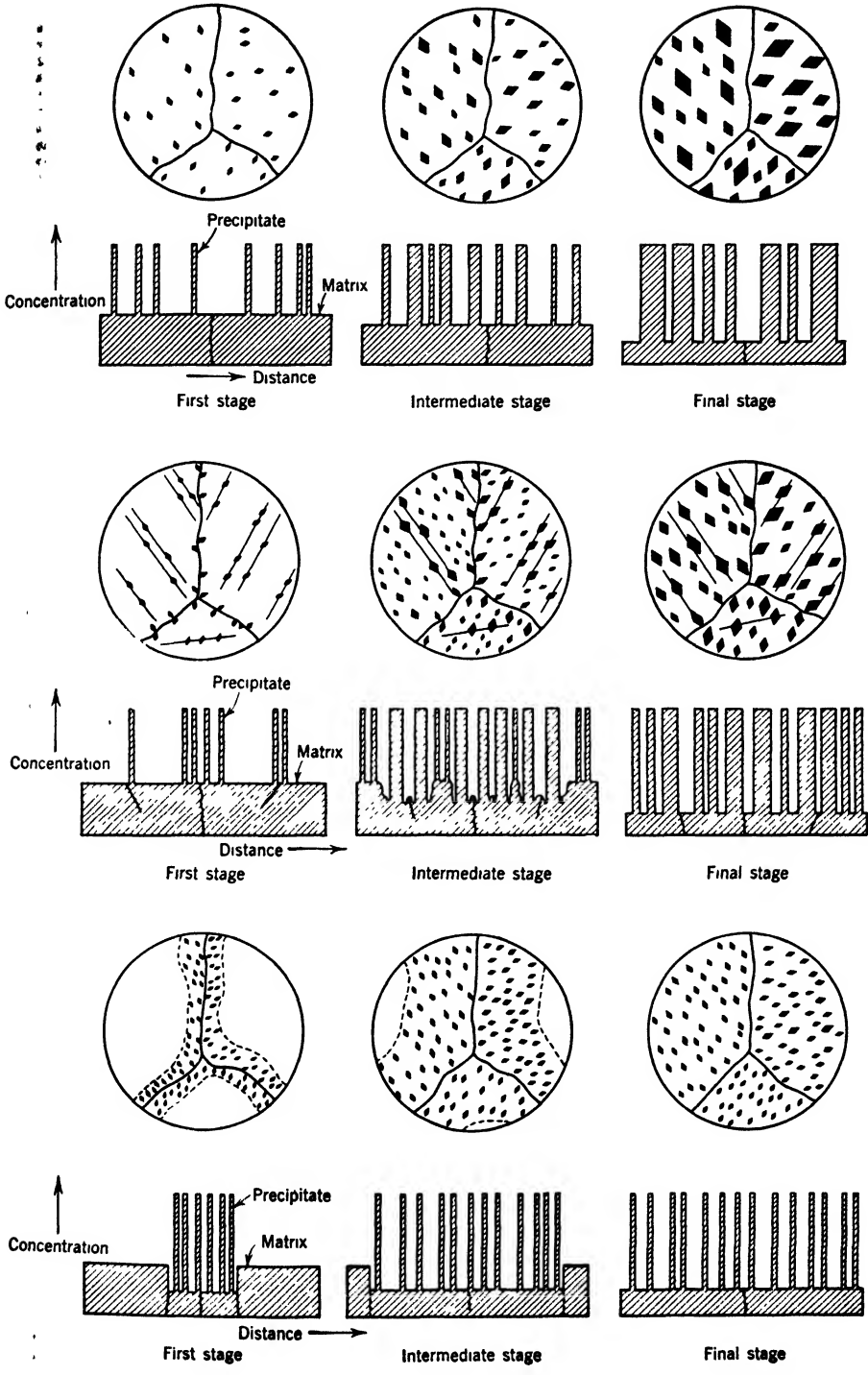
Because of the metastable condition of the quenched solid solution, its tendency to transform is already great, and only a relatively small additional atomic mobility is needed to initiate the precipitation reaction, i.e., to start the alloy changing toward its equilibrium state. As would be expected, the higher the temperature to which the quenched alloy is reheated, the more rapidly this change toward the equilibrium state will tend to proceed.

As the alloy is heated into a proper temperature range, there are two changes which must take place. First, nuclei of the precipitating phase must form. Second, these nuclei must grow into larger particles. The lower the temperature to which the alloy is heated, the more slowly these two changes will take place, and the greater will be the separation that can be noticed between their effects upon the mechanical properties. The three general ways in which a second phase precipitates from a supersaturated solid solution are illustrated in Fig. 245.

As has been noted, the first nuclei normally tend to appear at grain boundaries and in the vicinity of regions that have been strained by mechanical work either deliberately applied or resulting from thermal strains produced by too rapid quenching. Under favorable conditions, the first particles to form in these regions can be detected metallographically,

---

FIGURE 245. Diagrammatic representation of three general types of precipitation from a supersaturated solid solution by heat-treatment. *Top*, uniform or continuous type of precipitation. *Middle*, localized type of precipitation appearing preferentially at grain boundaries and along slip planes. *Bottom*, nonuniform or discontinuous type of precipitation appearing preferentially at grain boundaries. (From R. F. Mehl and L. K. Jetter, Ref. 13 at the end of this chapter, courtesy American Society for Metals.)



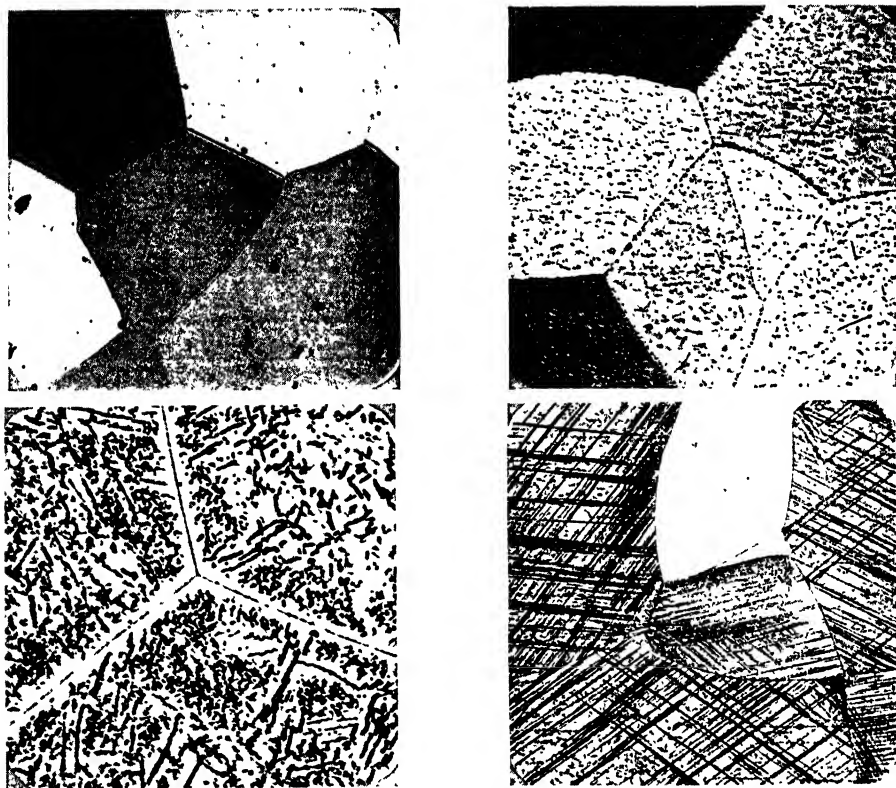


FIGURE 246. Typical metallographic structures of a 96% Al — 4% Cu alloy showing the various types of precipitate formation. Etched with Keller's reagent. For example of coarse uniform precipitation, characteristic of the fully annealed condition, see Fig. 244a. (Photomicrographs courtesy Aluminum Research Laboratories.)

a. (*Upper left*) As quenched, no precipitation.  $\times 500$ .

b. (*Upper right*) Localized precipitation both at grain boundaries and within the grains.  $\times 100$ .

c. (*Lower left*) Fine uniform precipitation on a geometrical pattern throughout the grains. (*Widmannstaetten* type.)  $\times 500$ .

d. (*Lower right*) Localized precipitation along slip planes.  $\times 100$ .

as shown in Fig. 246. Although the precipitation will tend to start in these more or less discontinuous regions, frequently it will be found that it will eventually tend to occur over the entire volume of the grain. The differences in microstructure for the various types of precipitation in an aluminum-copper alloy can be clearly seen in the photomicrographs shown. It will be readily understood from these why, after heating for a long enough period of time at a sufficiently high temperature, a structure will be produced by a quenching and aging treatment which is quite similar to that which would result from slow cooling from the solution temperature. In other words, the equilibrium structure tends to be produced by either method, as would

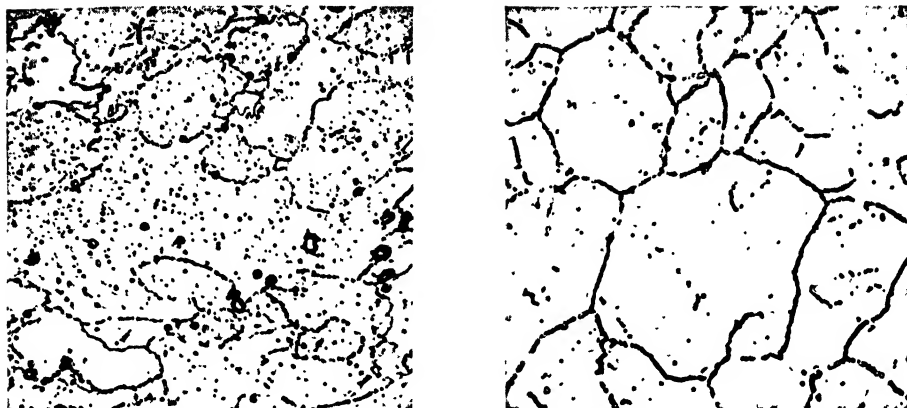


FIGURE 247. Localized precipitation of complex carbides at the grain boundaries of (*left*) ferritic (83% Fe – 17% Cr) and (*right*) austenitic (74% Fe – 18% Cr – 8% Ni) stainless steels. Etched electrolytically with oxalic acid.  $\times 750$ .

be anticipated, because only the number of phases present under equilibrium conditions is fixed. Their form and distribution and the manner in which they are produced may vary.

In Fig. 247 is shown an example of a localized precipitate which appears preferentially at the grain boundaries. This is the manner in which complex carbides tend to precipitate in stainless steels and is one reason why these alloys are not susceptible to appreciable precipitation hardening and why they sometimes do not have their anticipated corrosion resistance. Both of these points will be discussed in greater detail later.

#### PROPERTY CHANGES INCIDENT TO AGE-HARDENING

The general change in hardness occurring during aging at various temperatures is indicated in Fig. 248 for the beryllium bronzes and the deep drawing steels. A logarithmic scale has been used instead of a linear or other scale for the time axis, but only for the purpose of limiting its length. It will be noted that, in general, the higher the aging temperature, the more rapidly is the peak hardness attained. The maximum properties, however, depend on a particular combination of time, temperature, and composition. In Fig. 249, data are plotted for the alloy of aluminum with about 4% copper. This alloy can be improved to such an extent that its tensile strength is almost 50% greater than the value before heat-treatment, and the yield strength may be more than doubled. Improvements of this magnitude are certainly of definite engineering interest. Furthermore, these improvements are permanent to all intents, and will not tend to change with time. The reason for this is that the change has been pro-



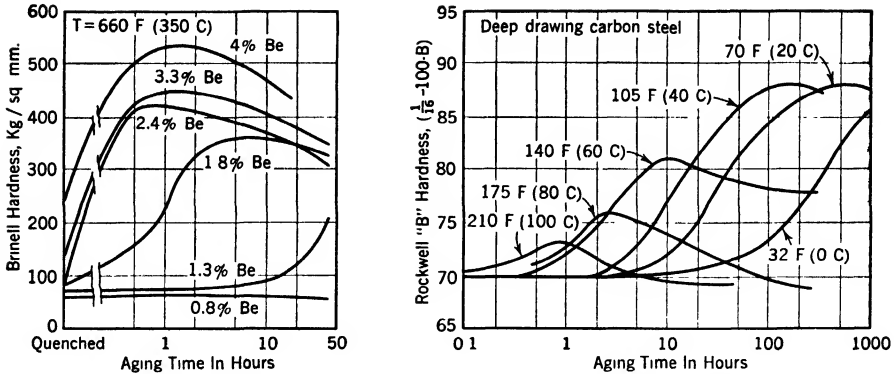


FIGURE 248. General nature of the change in properties with time of aging. In both graphs a logarithmic time scale has been used, but solely for convenience and economy of space.

a. (Left) Change in Brinell hardness, with time, of copper alloyed with different amounts of beryllium during aging at a constant temperature of 660 F (350 C). (After G. Masing and O. Dahl.)

b. (Right) Change in Rockwell B hardness, with time, of deep-drawing carbon steel after quenching from about 1300 F (700 C) and aging at the temperatures indicated. (After J. Johnston, *Trans. A.I.M.E.*, 150, 1942, 1.)

duced as the result of a certain definite atomic mobility. Cooling after the aging treatment must lead to a condition in which this mobility is decreased. Therefore, the conditions produced by aging will not be modified by subsequent treatment at a lower temperature, even though they would be affected by further treatment at the same temperature or by treatment at a higher temperature. Thus, the alloy would be satisfactory for use at appreciably lower temperatures, and unsatisfactory for use at temperatures only slightly lower, or of the same magnitude or higher. This, naturally, is an important factor in considering applications for age-hardening alloys.

The logarithm of the time required to produce maximum hardness by aging for a given alloy appears to be a linear function of the reciprocal of the absolute temperature as indicated in Fig. 250.<sup>11</sup> For the alloys shown it can be seen by extrapolation that at a temperature of 500 F (260 C) maximum hardness can be reached in times of the order of a few minutes whereas at temperatures in the vicinity of 100 F (38 C) times of the order of millions of years would be required. Statements of this sort are, of course, somewhat empirical since data secured within a reasonable time have been extrapolated to lower temperatures where the times are too long to be tested experimentally. However, the conclusions seem to be in accord with the experimental data available even though they must not be used too literally.

<sup>11</sup> See also, R. F. Mehl, *Trans. A.I.M.E.*, 122, 1936, 11-56.

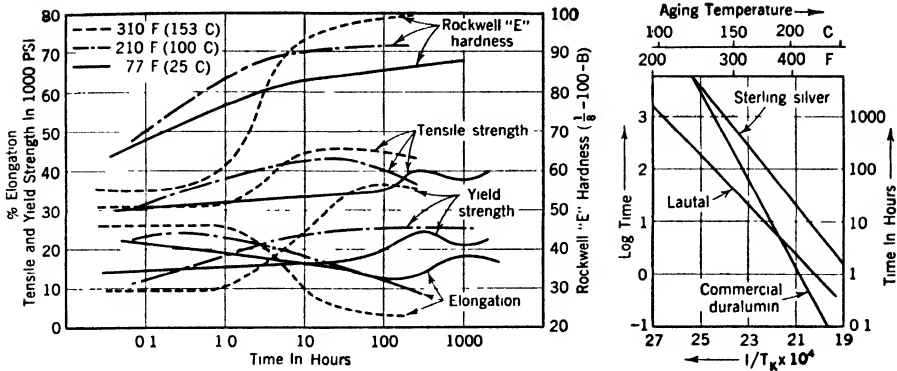


FIGURE 249. (Left) The effect of different aging temperatures on the Rockwell E hardness, the tensile and yield strengths, and the elongation of a wrought aluminum alloy (about 4% copper) quenched into oil from 16 hr at 975 F (525 C). (After W. L. Fink and D. W. Smith, *Trans. A.I.M.E.*, 128, 1938, 223.)

FIGURE 250. (Right) Rates of aging at different temperatures for the alloys: *Lautal*, containing 4.5% Cu—0.75% Si—0.75% Mn—rem. Al (after C. H. M. Jenkins and E. H. Bucknall), *Duralumin*, containing 4.19% Cu—0.58% Mg—0.14% Si—0.63% Mn—0.32% Fe—0.08% Cr—rem. Al (after M. Cohen), and *sterling silver*, containing 8.71% Cu—91.28% Ag (after M. Cohen), as measured by the times to attain maximum tensile strength.

#### MECHANISM OF AGE-HARDENING PROCESSES

The reasons for the changes in mechanical properties which occur as the result of aging certain alloys in the proper temperature range are as yet somewhat controversial.<sup>12</sup> However, since it is known with reasonable accuracy that the size of the particles increases with the time of aging at a given temperature, the change in properties must be related in some manner to the particle size of the precipitate at any given instance. This, of course, means the average size of all the precipitating particles rather than the size of any particular ones.

Probably within certain ranges of sizes, the precipitating particles exert a pronounced strain of some sort on the solvent lattice; and, because of this strain, produce marked changes in physical properties. Whether this critical condition occurs during the stage in which nuclei are forming or the stage during which growth occurs is of little practical importance. The essential thing is that the aging process must be stopped within a certain time interval if optimum properties are to result. If the aging time is too short, the best properties will not have been attained, and if it is too long, the maximum properties will have been passed. However, unless maximum

<sup>12</sup> See, for example, M. L. Gaylor, *Journ. Inst. Metals*, 60, 1937, 249–266; *ibid.*, 66, 1940, 67–84; also W. Fink and D. W. Smith, *Trans. A.I.M.E.*, 137, 1940, 95–112.

properties are required it is frequently preferable to overage rather than to underage because by this treatment a decreased brittleness and a greater leeway in heat-treatment time is secured for essentially the same hardness.

#### FUTURE IMPORTANCE OF AGE-HARDENING ALLOYS

Since alloys of any of the dominant metals can be subjected to age-hardening, provided they conform to the solubility limitations which have been already discussed and the precipitate forms in the proper manner; and since the tendency for the solid solubility to decrease with decreasing temperature seems to be the rule rather than the exception, it would be anticipated that the age-hardening materials would be among the most important engineering materials of the future. The study of these alloys, although it was started about 1910, has as yet scarcely begun because of the tremendous amount of time required by any empirical methods of research. It is quite possible that the relatively near future will expand the number of such materials manyfold. In the aluminum- and magnesium-base alloys, in particular, the combination of a naturally low density with the improvement of mechanical properties made possible by age-hardening treatments, and the decreases in costs resulting from increased production and governmental subsidy, points to future engineering successes of this type of material.

#### HEAT-TREATING PROCESSES IN WHICH ALLOTROPIC MODIFICATIONS ARE IMPORTANT

The inversion of austenite to a mechanical mixture of ferrite and cementite which occurs in the eutectoid reaction in the iron-carbon alloys is the most important reaction of the allotropic modification type from both a scientific and a commercial viewpoint. A clearer understanding of the principles involved can be secured by some consideration of the fundamental significance and the scientific nature of the transformation that occurs. The reaction was first studied by Davenport and Bain using a method involving transformation at a constant temperature.<sup>13</sup>

It has already been pointed out that if an alloy of eutectoid composition (about 0.83% carbon) is held above  $A_1$ , it will be composed entirely of the homogeneous solid solution of carbon in gamma iron known as *austenite*. If this austenite is permitted to transform slowly on cooling, it will change to the lamellar mixture of ferrite and cementite known as *pearlite*. On the other hand, if it is cooled rapidly enough it will tend to remain as austenite

<sup>13</sup> See E. S. Davenport and E. C. Bain, *Trans. A.I.M.E.*, **90**, 1930, 117.

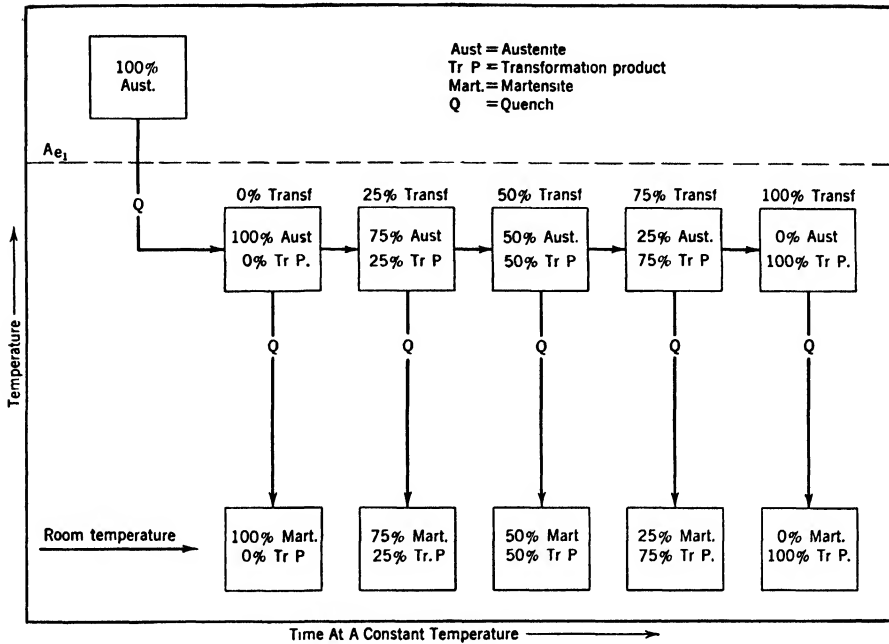


FIGURE 251. Schematic representation of the progress of transformation of austenite at a constant subcritical temperature. Note how quenching to follow the course of the transformation changes any untransformed austenite into martensite.

without transforming. Davenport and Bain took advantage of this fact in studying the process by one of the methods of physical chemistry. Specimens were first held at a temperature above the critical range until they had reached essential equilibrium. They were then cooled to some temperature below the eutectoid temperature, and held at that constant temperature until transformation was complete. At any of these subcritical temperatures, the process of transformation could be followed either by the microstructure, as illustrated schematically in Fig. 251, or by the change in some other property, such as hardness or volume. In any case, for each temperature a curve of per cent transformation versus time, similar to that shown in Fig. 252, could be plotted. If the data from all of these curves are assembled, as in Fig. 253, a plot of the temperature of transformation against the time, indicated on a logarithmic scale, of holding at that temperature is secured. This curve, because of its shape, is known as the *S-curve* of Davenport and Bain. For times to the left of the left-hand curve the austenite had transformed less than 1%, for times between the two curves it was in process of transformation, and for times to the right of the right-hand curve the transformation was more than 99% complete.

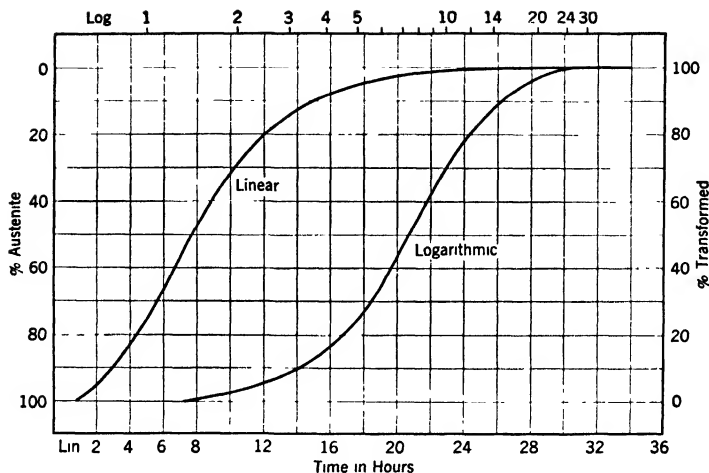


FIGURE 252. Typical curve showing progress of transformation of austenite as plotted both on linear and on logarithmic scales. Note that the reaction starts slowly and dies out slowly, attaining its maximum rate near the 50:50 range. (From E. C. Bain, *Trans. A.I.M.E.*, **100**, 1932, 27.)

Figure 253 is known to be incorrect in the region of martensite formation,<sup>14</sup> i.e., below about 350 F (180 C). All the evidence available indicates that martensite forms only on cooling and does not form by isothermal transformation like pearlite and bainite. Hence, the low-temperature portion of the S-curve should probably be drawn as a series of isothermal lines, each indicating a greater percentage transformation to martensite as the temperature decreases.

#### TRANSFORMATION OF AUSTENITE AT A CONSTANT SUBCRITICAL TEMPERATURE

The data contained in the S-curve give a great deal of information about the decomposition of austenite at a constant subcritical temperature, a treatment now known as *austempering*. They show, first of all, that any one of three different constituents may be formed, depending upon the actual temperature at which the transformation takes place:

1. A lamellar mixture of ferrite and cementite which has been named, in general, *pearlite*. This constituent will be formed at temperatures between the eutectoid temperature and about 1025 F (550 C).
2. A featherylike constituent, which is known as *bainite*, after its discoverer. This constituent is formed when austenite decomposes at temperatures between about 1025 F (550 C) and 350 F (180 C).

<sup>14</sup> See A. B. Greninger and A. R. Troiano, *Trans. A.S.M.*, **28**, 1940, 537-574.

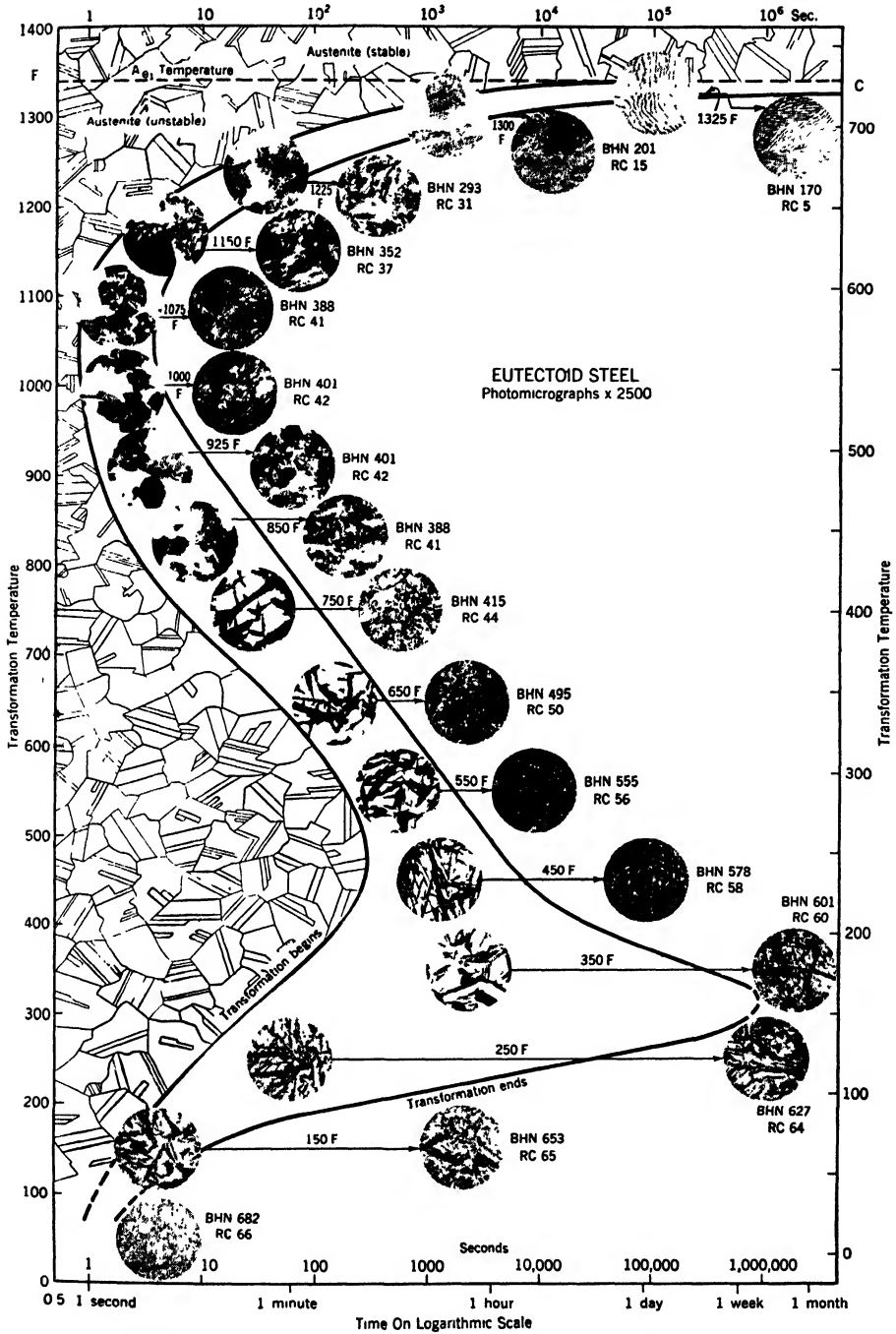


FIGURE 253. The S-curve of Davenport and Bain. (Courtesy U.S. Steel Corporation Research Laboratory, Kearny, N. J.)

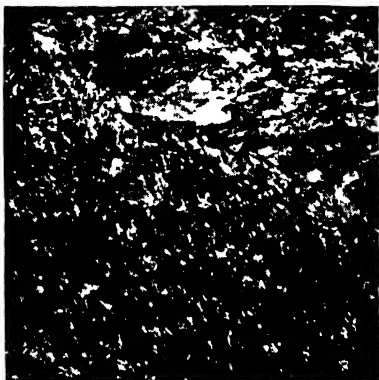
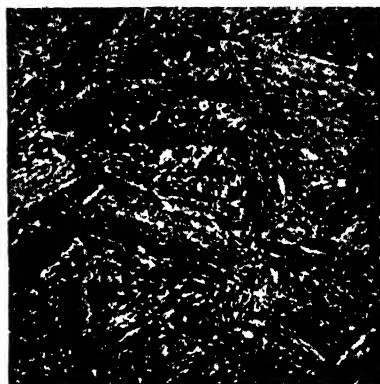
*a**a**b**b**c**c*

FIGURE 254. Metallographic structures produced by decomposing an eutectoid steel (0.89% C — 0.29% Mn — rem. Fe) at several different subcritical temperatures. *Left*, decomposed 50%. *Right*, decomposed 100%. All etched with saturated picral. Original magnification  $\times 2500$ ; reduced about one half in reproduction.



d



d

FIGURE 254 (continued)

a. Coarse lamellar pearlite, transformed isothermally at 1325 F (720 C).

b. Very fine nodular pearlite, transformed isothermally at 1075 F (580 C).

c. Coarse feathery bainite, transformed isothermally at 850 F (455 C).

d. Fine bainite, transformed isothermally at 550 F (290 C).

e. Martensite, formed by quenching into brine.

(Photomicrographs courtesy U. S. Steel Corporation Research Laboratory, Kearny, N. J.)



e

3. A needle-like constituent, *martensite*, the hardest constituent in heat-treated steels, which is formed at temperatures below about 350 F (180 C), depending upon the carbon content, in increasing amount as the temperature is decreased. This is probably a transition phase between austenite and ferrite (plus cementite) necessitated by the fact that the dissolved carbon does not have time enough to separate.

#### PEARLITE

The generic name pearlite covers a wide range of structures, all of which however are *lamellar* in nature. Those formed just below the eutectoid temperature, say at about 1325 F (720 C), tend to form very slowly, and are composed of coarse lamellae, as illustrated in Fig. 254a. Their hardness is therefore low, Rockwell C5. As the transformation temperature falls, the rate at which the transformation occurs increases, and the thickness of the layers decreases. This decrease in thickness is accompanied by



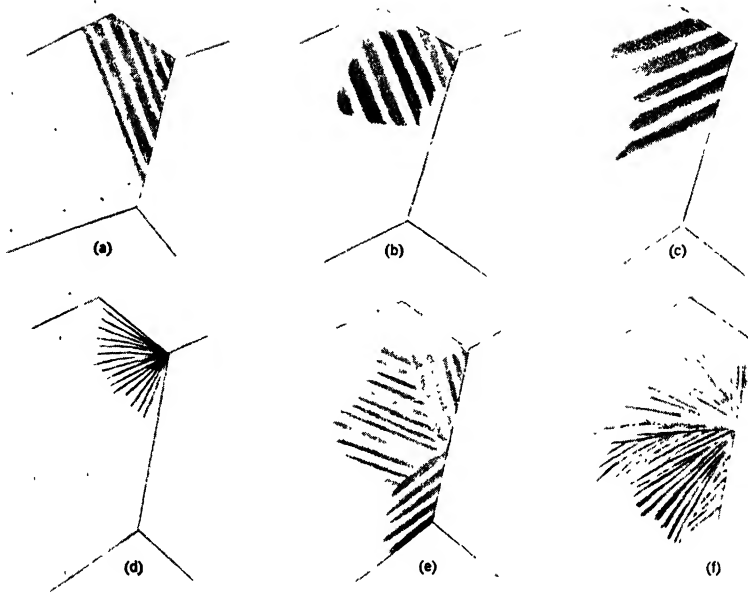


FIGURE 255. Possible modes of formation of pearlite as suggested by H. C. H. Carpenter and J. M. Robertson, and by H. Jolivet (*Journ. Iron & Steel Inst.*, Lond., 140, 1939, 95).

an appreciable increase in hardness to a maximum of about Rockwell C 42. The maximum rate of transformation occurs at about 1025 F (550 C), and transformation at about this temperature produces both the finest lamellae (Fig. 254*b*), and the hardest form of pearlite, about 400 Brinell.

These statements are in general accord with the principles which have already been stated for reactions of this sort:

- k. Transformations occurring under limited conditions of supercooling tend to produce relatively few nuclei; and, because of the comparatively large amount of atomic mobility resulting from the high transformation temperature, each of these nuclei will tend to grow comparatively large, resulting in coarse lamellae in the case of an eutectoid reaction. The reasons why a lamellar structure is formed are not as yet completely clear, but they are related to the obvious fact that the austenite which is transforming is saturated in both carbon and gamma iron, and hence reacts by getting rid of the carbon as cementite and the gamma iron as ferrite, alternately.<sup>15</sup>

<sup>15</sup> A complete study of this reaction is being carried out by R. F. Mehl and co-workers. See, for example, R. F. Mehl, *Trans. A.S.M.*, 29, 1941, 813-862.

2. As the amount of supercooling increases, i.e., as the transformation temperature decreases, the number of nuclei will increase; and, because of the lower atomic mobility, the thickness to which any of them can grow becomes less and the thickness of the lamellae produced will thus tend to decrease. As the amount of supercooling increases, the reaction tendency also tends to increase, and this decreases the time required for the reaction to start.

The formation of pearlite from austenite by several possible methods is indicated schematically in Fig. 255.

### BAINITE

The most rapid rate of formation of the constituent bainite occurs just below the knee of the S-curve. The so-called upper bainite formed in this temperature range is the coarsest form (Fig. 254c). As the transformation temperature decreases, the fineness of the bainite increases (Fig. 254d), and the rate of its formation decreases markedly.

As the transformation temperature of the bainite decreases, the hardness of the constituent also tends to increase. However, for a given hardness, bainite is much less brittle than tempered martensite, which gives it considerable commercial importance for some applications, especially where a small cross section permits isothermal heat-treatment to be used. In Fig. 256 is shown a comparison between the impact strengths of *austempered* steels of various hardnesses and those of steels quenched and tempered to the same hardnesses.

The formation of bainite is not as yet completely understood. However, it is believed to start with the formation of ferrite and to proceed at a rate determined, to some extent at least, by the diffusion of carbon. Since the rate of diffusion of carbon will decrease markedly with a decrease in trans-

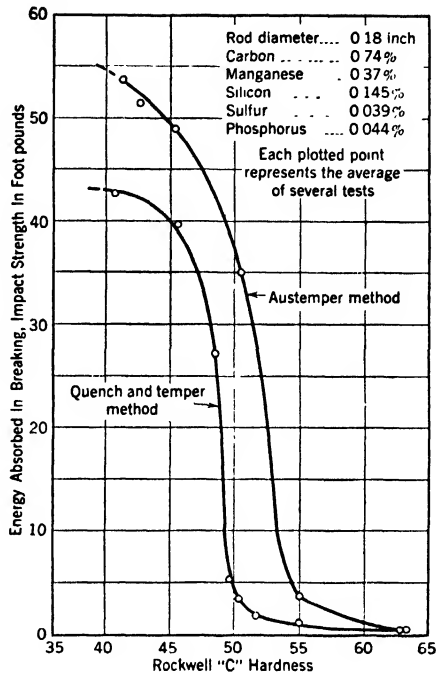


FIGURE 256. Comparison of impact strengths at various hardnesses of quenched-and-tempered and austempered steels. (Courtesy U.S. Steel Corporation Research Laboratory, Kearny, N. J.)

formation temperature, the rate of the reaction will also become appreciably slower.

#### MARTENSITE

It has already been commented that gamma iron, or its equivalent austenite, cannot be retained completely at room temperature in a plain carbon steel, although small amounts of untransformed austenite can be retained in high-carbon steels by rapid quenching. Instead the constituent martensite is always produced, no matter how rapidly the alloy is cooled. Although the conditions for the formation of martensite are not known entirely as yet, it is believed to result from the thermal and "transformation" strains produced in the austenite by rapid cooling below its temperature of stability. Because of these strains, relatively large blocks of the austenite crystals are transformed almost instantaneously, by some sort of a shearing process,<sup>16</sup> into the extremely hard constituent which is known as *martensite*. Because the carbon in the austenite does not have sufficient time to separate, the reaction can only proceed this far in the transformation to ferrite (plus cementite).

The amount of martensite apparently increases as the temperature to which the metal is cooled decreases. In other words, unlike the constituents pearlite and bainite, martensite is formed only on cooling. Thus, if a given piece of steel were quenched to only 200 F (95 C), a definite percentage of martensite would be produced. If it were quenched to 100 F (40 C), a greater percentage of martensite would be produced, and if it were quenched to room temperature, a still greater amount would result. The martensite needles (Fig. 254e) are very much coarser than the layers in the bainite constituent, and are appreciably harder. The hardness of a sample with a martensitic structure increases as the transformation temperature decreases, as might be expected, because of the greater amount which is transformed to martensite at the lower temperatures.

The temperature of transformation of austenite to martensite is markedly affected by the carbon content,<sup>17</sup> decreasing rapidly from a relatively narrow range occurring at about 1300 F (700 C) for a very low-carbon steel to a range about 450° F (250° C) wide beginning below 500 F (260 C) for an eutectoid steel. Thus, for the lowest carbon contents, it is not possible to retain untransformed austenite at room temperature since the martensite transformation will proceed to completion at higher tempera-

<sup>16</sup> See, for example, W. Hume-Rothery, V. G. Raynor, and A. T. Little, *Journ. Iron & Steel Inst. (Brit.)*, **145**, 1942, 143-149.

<sup>17</sup> This is discussed thoroughly by H. Carpenter and J. M. Robertson, Ref. 8 at the end of this chapter; and by J. M. Robertson, *Carnegie Scholarship Memoirs*, The Iron & Steel Institute, **20**, 1931, 1-64.

tures. However, with hypereutectoid steels, it is not difficult to retain small amounts of austenite at room temperature, and, in fact, cooling below room temperature must usually be resorted to if complete transformation to martensite is desired.

#### THE HARDNESS OF THE PRODUCTS OF AUSTENITE TRANSFORMATION AT CONSTANT TEMPERATURE

In Fig. 257 are plotted several mechanical properties of the various constituents into which austenite transforms directly as a function of the transformation temperature at which they are produced. It will be seen that although, in general,<sup>18</sup> the hardness and strength of the constituents increases as the transformation temperature decreases, the curve is by no means a smooth one. The properties involving ductility, also, seem to vary markedly with transformation temperature and to attain an optimum value for a specific range of reaction temperatures for both the pearlite and bainite reactions.

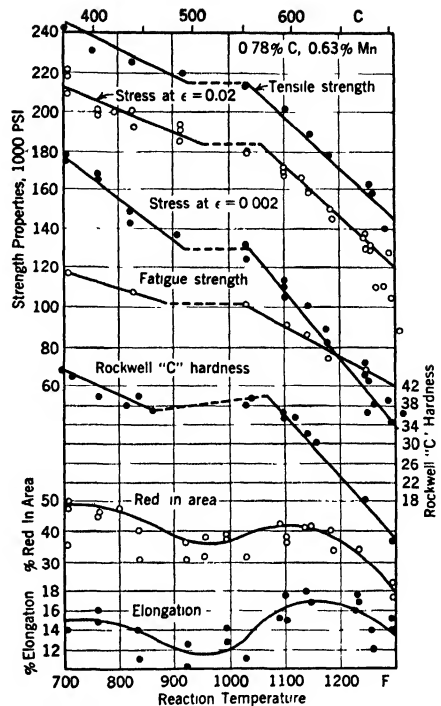


FIGURE 257. Mechanical properties of decomposition products of austenite as a function of their temperature of formation for a plain carbon eutectoid steel (0.78% C - 0.63% Mn - 0.014% P - 0.030% S - 0.18% Si - rem. Fe, austenitic grain size before quenching 8-9). All specimens furnace cooled after reaction. (From M. Gensamer, E. B. Pearsall, W. S. Pellini, and J. R. Low, Jr. in *Trans. A.S.M.*, courtesy American Society for Metals.)

#### EFFECT OF RATE OF COOLING UPON THE TRANSFORMATION OF AUSTENITE

Although the S-curve applies strictly only to transformations occurring at a constant temperature, the information which it contains can be applied, to some extent, to the more practical problem of the transformation of austenite on cooling, i.e., with a temperature that is continually decreasing, as represented schematically in Fig. 258.<sup>19</sup> Only the simplest case of a plain carbon eutectoid steel will be given as an illustration.

<sup>18</sup> For a more detailed description see M. Gensamer, E. B. Pearsall, W. S. Pellini, and J. R. Low, Jr., *Trans. A.S.M.*, 30, 1942, 983-1019.

<sup>19</sup> See also R. A. Grange and J. M. Kiefer, *A.S.M. Preprint No. 9*, 1940.

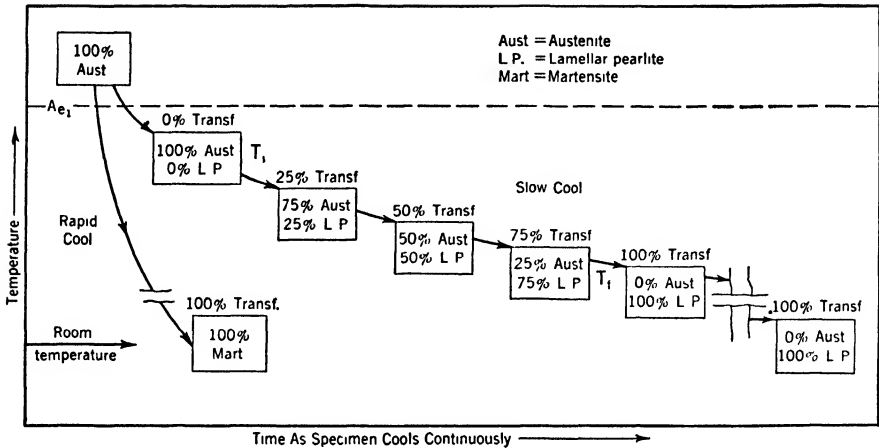


FIGURE 258. Schematic representation of transformation of austenite during continuous cooling at a given rate. Transformation does not begin until temperature  $T_1$  is reached. A certain amount of austenite transforms at each temperature, as it is reached during cooling, to a pearlite of corresponding fineness, the entire transformation being complete by the time temperature  $T_2$  is reached. The course of the transformation can be followed by quenching to change any untransformed austenite into martensite. Note that a rapid cool, faster than the critical cooling rate, completely prevents the formation of lamellar pearlite, producing martensite instead. (After R. A. Grange and J. M. Kiefer.)

**SLOW RATES OF COOLING** When slow rates of cooling are used, such as would result from cooling in the furnace or in some insulating material, the rate of removal of energy from the specimen is very slow and hence transformation would tend to begin at a comparatively high temperature. Austenite, in this range of temperatures, would tend to transform to a structure which was essentially all coarse pearlite. Since the transformation itself will also give off a certain amount of heat energy, this will slow up the rate of cooling even more, and, therefore, tend to give a fairly uniform structure.

**INTERMEDIATE RATES OF COOLING** As the rate of cooling is increased, as by cooling in air, for example, the transformation will tend to begin more quickly and at a lower temperature. Both of these conditions result in a finer pearlitic structure; but again the evolution of heat energy will tend to slow up the reaction to some extent.

**RAPID RATES OF COOLING** As the rate of cooling is further increased, by gas or liquid quenching, the transformation will tend to take place still more rapidly and at a still lower temperature. If the rate of cooling is increased to such an extent that the austenite is cooled below the knee of the S-curve, about 1025 F (550 C), in a shorter interval of time than that

required for the transformation to begin, then the austenite will not transform to pearlite at all, but will be carried to a much lower temperature before transformation begins.

The rate of cooling which is just fast enough to avoid the formation of any lamellar constituent is known as the *critical cooling rate*. For rates of cooling just slower than this rate, a certain amount of very fine or nodular pearlite will tend to be produced; but the entire alloy may or may not transform to the lamellar constituent, depending upon the exact rate of cooling and the energy released by the portion which transforms. For rates of cooling faster than the critical cooling rate, no transformation will tend to take place until the region of initial martensite formation is reached, at about 350 F (180 C), unless the specimen is quenched into a bath held at a temperature higher than this and kept in that bath until transformation to bainite is complete. It must be remembered, of course, that the rate of removal of heat will always be greater at the surface than in the interior of the piece and that the thickness of the section must, for this reason, be considered in applying these concepts.

It can be seen, therefore, that the constituent bainite cannot be produced in plain carbon steels, except possibly in small amounts because of peculiarities, by any direct cooling technique. Some form of interrupted cooling must be used in order to produce it.

The changes taking place in austenite for various rates of cooling may be summarized in relation to the S-curve, as indicated in Fig. 259. Austenite cooled at a rate sufficiently slow to permit transformation to the pearlitic constituent will transform at a comparatively high temperature as indicated. Austenite cooled at a rate sufficiently rapid to avoid the knee of the curve entirely will transform at very much lower temperatures to a martensitic constituent. There will be also a range of cooling rates between these two limits in which part of the austenite will transform to pearlite and the remainder to martensite. The metallographic structures of these intermediate stages are illustrated in Fig. 260.

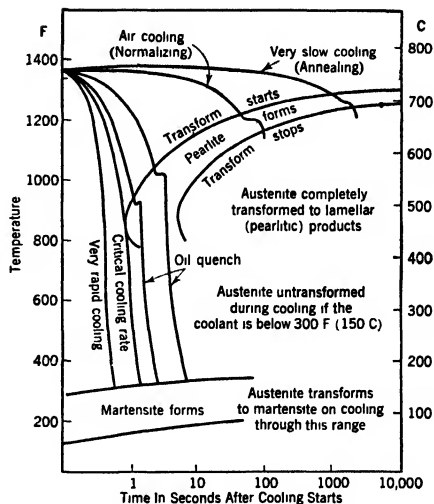


FIGURE 259. Schematic representation of the relation between cooling rate and temperature of initial transformation of cooling as indicated by the S-curve. (After E. C. Bain.)

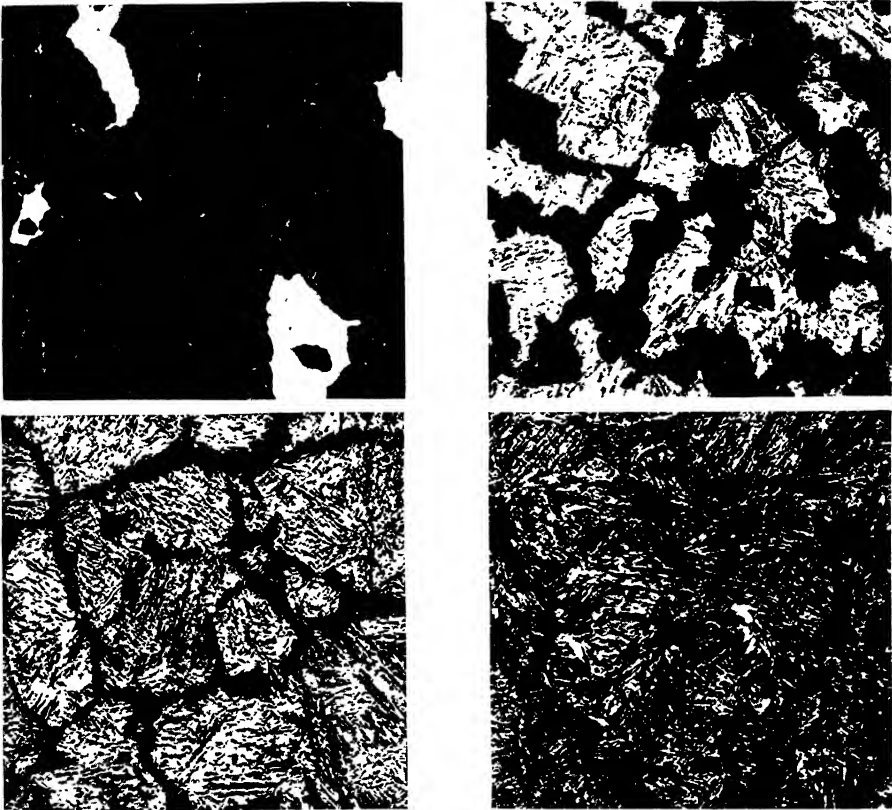


FIGURE 260. Photomicrographs of eutectoid iron-carbon alloys that have transformed partly to dark etching nodular pearlite and partly to light etching martensite during direct quenching to room temperature. Etched with picral.  $\times 500$ . As indicated in Fig. 259, increased cooling rates give decreased amounts of nodular pearlite.

#### DECOMPOSITION OF MARTENSITE UPON REHEATING

Although the constituents pearlite, bainite, and martensite will remain essentially unchanged at any temperature below that at which they were formed, on reheating to any higher temperature they tend to decompose into a granular mixture of cementite and ferrite. In these *granular* or *spheroidal* mixtures, the cementite tries to assume the form of small globules rather than the lamellar form it has in pearlite. This is generally found to be the tendency in any constituent as it approaches complete equilibrium, because a spherical shape includes the greatest possible volume within the smallest possible surface.

It may be stated, in general, that the higher the temperature to which a given constituent is heated, the larger will be the cementite granules produced in it. Whether, under true conditions of equilibrium, these will

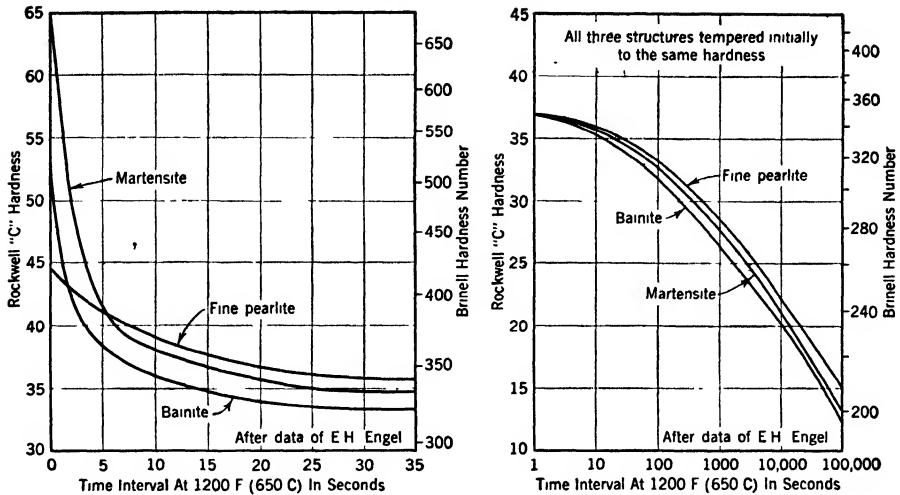


FIGURE 261. The softening, at 1200 F (650 C), in three characteristic structures of carbon steel, (*left*) with increase of short-time interval, (*right*) with increase of long-time interval after first softening all three to the same hardness by tempering the martensite 16 sec, the bainite 7 sec, and the fine pearlite 20 sec. (Courtesy E. C. Bain, Ref. 2 at the end of this chapter.)

eventually grow to such a size that only one cementite spheroid results is an academic question that need not concern the user of metals. For all practical purposes, there is a limiting size of particle which is some function of the reheating temperature for times of the order of magnitude most commonly used.

The change of hardness with tempering temperature for the various initial constituents is shown in Fig. 261.<sup>20</sup>

#### EFFECT OF CARBON CONTENT UPON THE HARDNESS OF TEMPERED STEEL

Since the amount of iron carbide in any steel may be computed and will tend to increase with the carbon content, it would be expected that the hardness of a spheroidized steel would be affected by the carbon content as well as by the tempering temperature. In Fig. 262 this relationship is shown for steels containing 0.35%, 0.80%, and 1.2% carbon, starting with a structure which was originally martensitic.

The hardness of the fully hardened martensitic *structure*, i.e., of the mixture of martensite and possible other constituents, will also depend upon the carbon content. This relationship (Fig. 263) shows that a carbon content of about 0.55% must be exceeded in the quenched steel if a fully hardened (Rockwell C65) structure is to result.<sup>21</sup>

<sup>20</sup> See E. H. Engel, *Trans. A.S.M.*, 27, 1939, 1-17.

<sup>21</sup> See J. L. Burns, T. L. Moore, and R. S. Archer, *Trans. A.S.M.*, 26, 1938, 1-36.



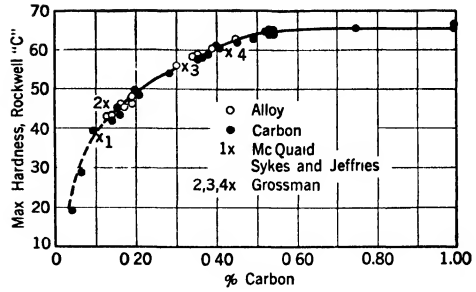
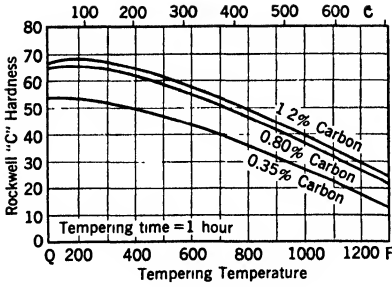


FIGURE 262. (Left) The softening of quenched carbon steels by tempering for 1 hr at indicated temperatures. (Courtesy E. C. Bain, Ref. 2 at the end of this chapter.)

FIGURE 263. (Right) Maximum hardness of quenched alloy and carbon steels vs. carbon content. (From J. L. Burns, T. L. Moore, and R. S. Archer in *Trans. A.S.M.*, courtesy American Society for Metals.)

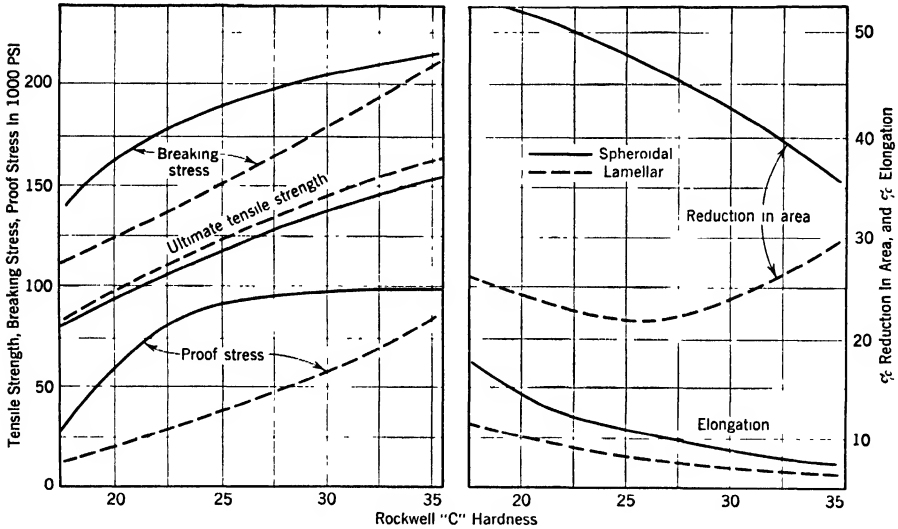


FIGURE 264. The influence of microstructure upon the tensile properties of an eutectoid steel at various identical hardnesses as shown for spheroidal structures (tempered martensite), and lamellar structures (pearlitic).

(Left) Ultimate tensile strength, proof stress, and breaking stress computed on the reduced section.

(Right) Reduction in area and elongation.

(Courtesy E. C. Bain, Ref. 2 at the end of this chapter.)

COMPARATIVE PROPERTIES OF LAMELLAR AND SPHEROIDAL STRUCTURES

Although identical hardnesses can be secured in either lamellar or spheroidal structures, the other mechanical properties are not always

similar. The relationship between them is shown in Fig. 264 for the most common properties.<sup>22</sup> It will readily be seen that, with the exception of ultimate tensile strength, the spheroidal type of structure is superior.

#### EFFECT OF AUSTENITE GRAIN SIZE UPON AUSTENITE TRANSFORMATION

It has been found that the grain size of the austenite affects the rate at which it transforms, even though identical quenching temperatures are used. This effect is illustrated in Fig. 265, in which the initial rates of transformation at the knee of the S-curve are indicated for both coarse-grain and fine-grain steels. It is seen that a fine-grain steel (G.S. 8-9) tends to transform much more rapidly than a coarse-grain steel of identical composition.<sup>23</sup> This may be explained by the greater amount of grain boundary material in a given volume of the fine-grain steel, as illustrated in Fig. 266. It has already been mentioned that such internal surfaces tend to produce regions favorable for transformation from which the new phase can grow. In a fine-grain steel, therefore, not only are there more centers at which the new phases can start to grow, but also less material in a given grain to be consumed. Both of these conditions tend to lead to a more rapid rate of transformation.

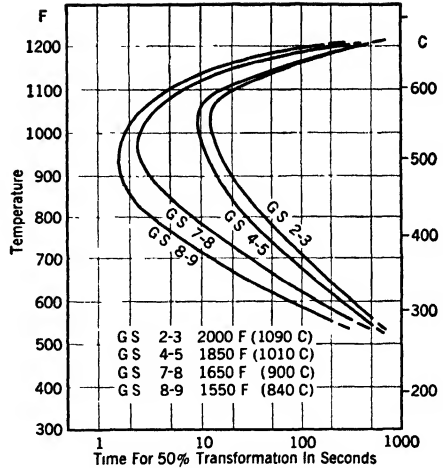


FIGURE 265. Comparative time intervals for 50% transformation in a single steel as heated to four different temperatures in the austenitic range prior to transformation, with corresponding difference in austenitic grain sizes (G.S.). Note how the curve for the finest grain steel (G.S. 8-9) is displaced to the left thus indicating a greater tendency to transform to pearlite than that of the coarsest grain steel (G.S. 2-3). (From *U.S.S. Carillo Steels*, by permission of Carnegie-Illinois Steel Corporation.) Cf. Fig. 282.

#### METALLOGRAPHIC CONSTITUENTS IN HEAT-TREATED STEELS

In modern terminology, any lamellar constituent produced by the transformation of austenite is known as pearlite, although a further classification may be given by calling it *coarse*, *fine* or *very fine pearlite*. In the very

<sup>22</sup> See J. R. Vilella, G. E. Guellich, and E. C. Bain, *Trans. A.S.M.*, **24**, 1936, 225.

<sup>23</sup> See E. C. Bain, *Trans. Amer. Soc. for Steel Treating*, **20**, 1932, 385.

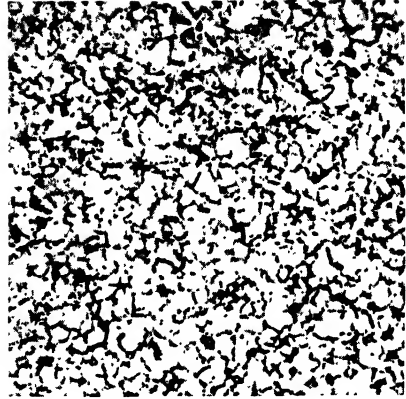
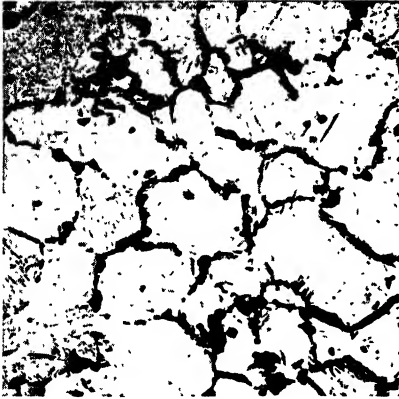


FIGURE 266. Coarse (*left*) and fine (*right*) austenitic grains delineated by nodular pearlite as a result of quenching at a rate just slower than the critical cooling rate. Etched with picral.  $\times 100$ . (Photomicrographs courtesy U.S. Steel Corporation Research Laboratory, Kearny, N. J.)

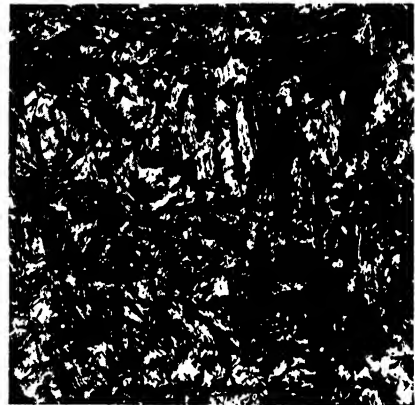


FIGURE 267. Metallographic appearance of various types of martensite. *a.* (*Left*) White, as freshly transformed by quenching. *b.* (*Right*) Black, after tempering at a low temperature. Etched with picral,  $\times 500$ .

fine pearlite, the growth of a given pearlite colony would be by a nodular process so this constituent is sometimes called *nodular pearlite*.

The extremely hard and brittle constituent produced by cooling austenite more rapidly than the critical cooling rate is called *martensite*. This constituent, sometimes termed *white martensite*, when properly formed and prepared metallographically is light gray in color as indicated in Figs. 254e and 267a. However, after tempering at a low temperature, it tends to etch darker, probably because of the precipitation in it of minute particles of iron carbide. This form is known as *black martensite* (Fig. 267b).

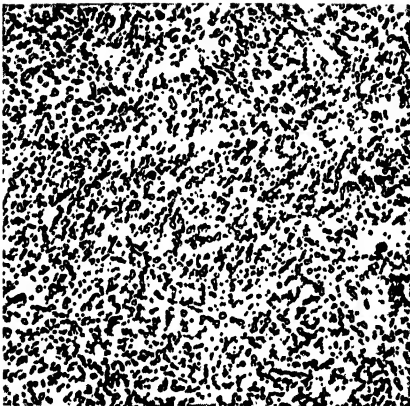
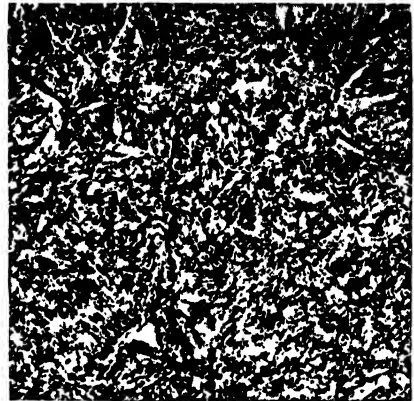
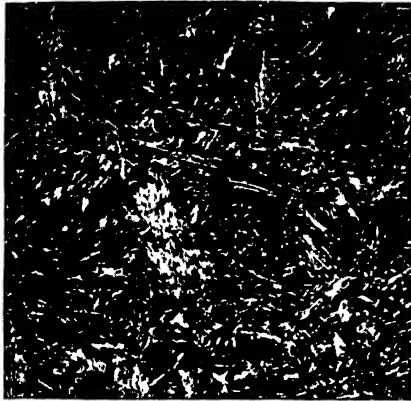


FIGURE 268. Metallographic appearance of granular structures produced by tempering martensite. Etched with picral.  $\times 500$ . (Photomicrographs by M. C. Fetzer.)

- a. (Upper left) Very fine spheroidized cementite (*troostite*).  
 b. (Upper right) Fine spheroidized cementite (*sorbite*).  
 c. (Lower left) Coarsely spheroidized cementite (sometimes called *spheroidite*).

The large dark needles seen in Fig. 267a probably formed just below the start of the martensitic transformation range and were tempered slightly before the steel could cool to room temperature.

Pearlite and martensite are the only two constituents that can be produced normally from the transformation of austenite by direct cooling.

Considerable ambiguity arises in the naming of the constituents produced by tempering martensite. Strictly, they are all probably *spheroidal* or *granular* constituents in which the granules have varying degrees of fineness. However, the very fine granules are very difficult to resolve under the microscope (Fig. 268) and in addition, because of their fine state of dispersion, they are extremely difficult to prepare satisfactorily for metallographic examination because their rate of etching is so rapid. Hence the convention has arisen to call *troostite* any tempered structure that can be resolved only with difficulty, if at all. If the structure can just be resolved, it is generally classed as *sorbite*; and if the particles are easily resolved under moderate magnifications, the structure is known as *spheroidite* or

simply as *spheroidized* or *divorced cementite*. It will readily be comprehended that these classifications are more or less arbitrary, and depend to a large extent upon the skill of the metallographer in preparing the specimen and on the quality of the optics used. There can be no exact division between the various constituents even though certain investigators have tried to establish such limits.

Because of the importance which metallography plays in the identification of these phases, a further confusion existed<sup>24</sup> before the classic work of Davenport and Bain established the real identity of the transformation products. For a long time the finest nodular pearlites could not be resolved under the microscope. Hence, they were also termed *troostite*, because they etched to a structure somewhat similar in appearance to that produced by tempering, and in addition had certain mechanical properties, notably hardness, similar to those found in the tempered structures. The fact that they were essentially different was recognized by designating the quenched structures *primary troostite* and the tempered structures *secondary troostite*. Likewise, the fine pearlite formed on quenching at somewhat slower rates could often not be resolved well with the techniques and the optical equipment available, so this was designated *primary sorbite* in contrast to the *secondary sorbite* produced on tempering. This terminology is still used to a certain extent although it is generally being discouraged. In any subsequent discussions here, the lamellar constituents produced by transformation of austenite during direct cooling will always be called *pearlite*, and the spheroidal or granular structures produced by tempering martensite will be designated as *troostite*, *sorbite*, or *spheroidized cementite*, as the case might be, merely to give some idea of the size of cementite granules involved.

#### EFFECT OF ALLOYING ELEMENTS UPON THE TRANSFORMATION OF AUSTENITE

With the possible exception of cobalt, all of the alloying elements in steel, if dissolved in the austenite before cooling, tend to shift the S-curve toward the right, i.e., toward the higher time axis, as illustrated for different amounts of nickel, manganese, and chromium in Fig. 269. This means, in general, that the transformation of austenite to any constituent on cooling will take place more slowly in an alloy steel than it will in a plain carbon steel. This effect is in addition to the effects of the alloying elements upon the eutectoid composition and temperature which have already been

<sup>24</sup> See, for example, A. Sauveur, Ref. 4 at the end of this chapter.

mentioned, and applies, naturally, only to those cases in which austenite is stable at a high temperature, and tends to decompose to a mixture of ferrite and cementite at lower temperatures.

The temperature of the knee of the S-curve is in general very little changed by the addition of moderate amounts, i.e., less than 5%, of alloying elements. However, the temperatures at which martensite tends to be produced on cooling may be appreciably affected, usually being lowered, and the curve itself may become more complex because of the occurrence of additional reactions or because some alloying elements have a much greater effect on the rate of formation of pearlite than on the rate of formation of bainite. This means, in general, not only that it is easier to cool an alloy steel at such a rate that the austenite will have no tendency to transform to pearlite, but also that some alloy steels may be cooled to room temperature without even transforming to martensite. Such steels then would be austenitic at room temperature, although they might tend to change to a martensitic form during cooling below room temperature,<sup>25</sup> or during cold-working.

For only a few applications is it desirable to have an *austenitic steel* at room temperature, and these usually call for steels of the wear- or corrosion-resisting types. The other decomposition products are more valuable in producing the mechanical properties which are of such great interest in engineering. The main effect of moderate amounts of alloying elements, therefore, from the practical viewpoint, is to permit a given structure or property to be produced by a slower rate of cooling than could be used with a plain carbon steel. This is of considerable importance since the more drastic the rate of cooling is, the greater will be the internal stresses produced by the cooling, and the greater the tendency for the piece to crack during quenching. The use of a slower rate of cooling tends to decrease the

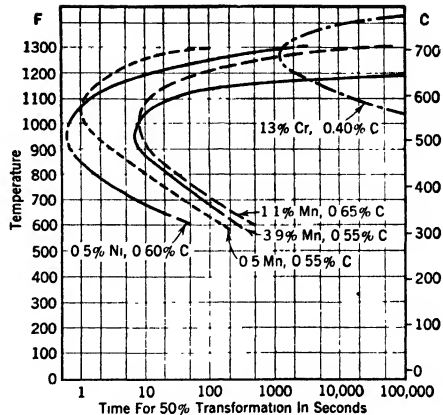


FIGURE 269. Comparative time intervals for 50% transformation in steels containing different amounts of nickel, manganese, and chromium. Note that a shift of the curve toward the right indicates a slower rate of transformation and hence a greater tendency for an austenitic or a martensitic structure to be produced. (From *U.S.S. Carilloy Steels*, by permission of Carnegie-Illinois Steel Corporation.)

<sup>25</sup> See, for example, G. V. Luerssen and O. V. Greene, *Trans. A.S.M.*, **19**, 1931-32, 501-543.

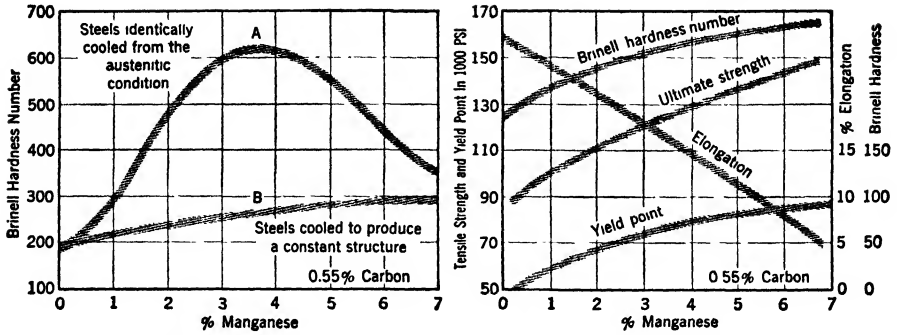


FIGURE 270. (Left) Effect of manganese upon the hardness of 0.55% carbon steels when identically cooled from the austenitic condition, Curve A. Curve B indicates similar data when secured on steels so cooled as to have constant structures. (Courtesy E. C. Bain, Ref. 2 at the end of this chapter.)

FIGURE 271. (Right) Effect of dissolved manganese in strengthening the ferrite of a 0.55% carbon series of uniform, lamellar structures. (Courtesy E. C. Bain, Ref. 2 at the end of this chapter.)

possibility of failure due to cracking, and gives a greater leeway in quenching time to produce a given structure.

In comparing alloy steels of mild alloy content with plain carbon steels, it is not feasible to compare the properties produced by cooling at given constant rates, because of the differences in transformation rates in the two materials. A much more logical method is to quench at whatever rates will produce identical structures in the two steels, and then compare their properties. This has been done in Fig. 270 for hardness with mild manganese and plain carbon steels. In curve A, the hardnesses have been compared for similar rates of cooling, and it will be apparent that marked differences in hardness result. In curve B, on the other hand, they have been compared after cooling at rates that produce similar structures. It will be noticed that the hardnesses are much more consistent under these conditions.

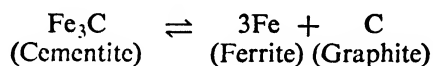
In Fig. 271 the effects of varying small amounts of manganese upon the mechanical properties of 0.55% carbon steels, cooled to similar structures, are shown. Although the additional amounts of manganese tend to increase all the strength properties and to decrease the elongation, these changes are by no means as great as might have been anticipated. This serves to emphasize the point that the most important effects of alloying elements, in the small amounts customarily used, are to decrease the rate of transformation of the austenite, and to permit the use of slower rates of cooling to secure given structures and properties rather than to modify very extensively the properties resulting from a given structure.

However, certain of the alloying elements, such as copper, nickel, silicon, phosphorus and, to a limited extent, manganese and chromium, act principally by dissolving in the ferrite, thereby hardening and strengthening it to some extent regardless of the heat-treatment.

#### MALLEABILIZING

The specific reactions occurring in the malleabilizing of white cast iron by heat-treatment are still somewhat incompletely understood, and are probably rather complex.<sup>26</sup> However, a simplified explanation of them, which probably does not deviate too greatly from the actual processes, is of assistance in understanding the necessity for the rather complicated heat-treatments that have already been discussed.

The essential transformation in malleabilizing is the decomposition of the metastable compound, iron carbide, into the stable constituents ferrite and graphite, as indicated by the equation:



This is, of course, possible because of the nature of the iron-cementite and iron-graphite constitutional diagrams, cf. Fig. 233. Graphite is the more stable constituent, especially in the presence of the proper impurities.

The white cast iron used will be composed, essentially, of two phases, viz., austenite and cementite above and ferrite and cementite below the critical temperature range. These may be aggregated as the eutectic, ledeburite, or as the eutectoid, pearlite, but the basic nature of the structure will not be so changed.

The malleabilizing heat-treatment, it will be recalled, consists of two essential steps: (a) a long-time soak at about 1650–1750 F (900–950 C); and (b) a very slow cool through the critical range around 1400 F (725–750 C). During the first of these steps the important reaction is most probably:



involving a decomposition of nearly all the free cementite. The presence of two austenites is shown because the constitutional diagram indicates that austenite saturated with cementite will have a different composition from austenite saturated with graphite. However, this change may not take place in the actual heat-treatment, although it probably does. In any case, only a certain proportion of carbon can be gotten into the graphitic form

<sup>26</sup> See, for example, A. Sauveur and H. L. Anthony, *Trans. A.S.M.*, 23, 1935, 409–421.



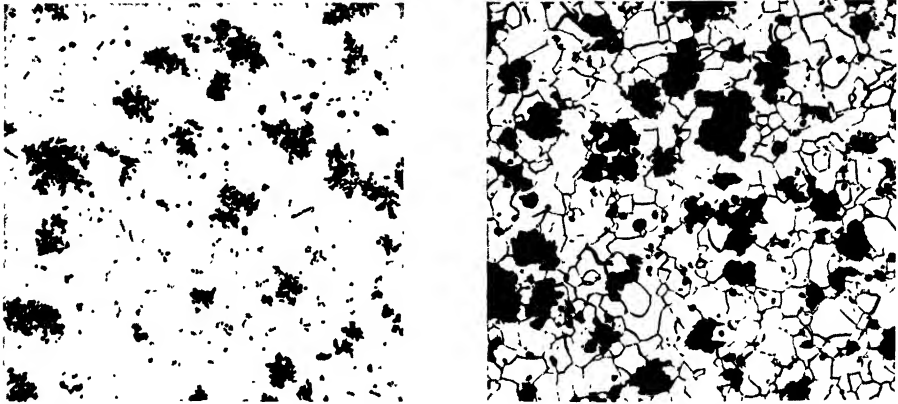


FIGURE 272. Metallographic structures typical of commercial malleable cast iron.  $\times 100$ . (*Left*) Unetched. (*Right*) Etched with nital. (See also Fig. 471 for metallographic structures of the less common pearlitic, sorbitic, and martensitic types.)

by this treatment alone, because the austenite will always remain saturated. If, after this treatment, the casting is cooled normally to room temperature, the *pearlitic malleable* structure, consisting of pearlite and temper carbon, will result (Fig. 471).

If the full *ferritic malleable* structure is desired, the second stage of heat-treatment must also be given. During the slow cool through the critical range the austenite tends to decompose into ferrite and cementite in the form of pearlite. However, because of the presence of existing nodules of graphite, either this decomposition does not occur or else the cementite formed decomposes fairly rapidly into the more stable forms: ferrite and graphite. The ultimate result of this treatment is to produce a structure composed only of ferrite and nodular graphite, the true structure of malleable cast iron (Fig. 272). Frequently the metal is reheated and recooled several times from just above to just below the critical range in order to assist the decomposition process in this second stage.

#### CLASSIFICATION OF COMMERCIAL HEAT-TREATMENTS

A joint committee, representing the American Society for Testing Materials, the Society for Automotive Engineers, and the American Society for Metals, has prepared a series of standard definitions to clarify the use of common terms employed in the heat-treatment of metals. These have been issued as A.S.T.M. Standard E44. The definitions used here are in general agreement with them. Unfortunately, the various metallurgical industries, ferrous and nonferrous, have not standardized upon these terms or upon any others. These discrepancies will be noted wherever possible.

Commercial heat-treating processes are generally intended to accomplish one of three purposes:

1. To produce, in the alloy, conditions approximating equilibrium.
2. To retain at a low temperature, i.e., room temperature, structures which are in essential equilibrium at some elevated temperature.
3. To produce a more or less definite atomic mobility, by reheating for varying periods of time, in order to permit a closer approach to equilibrium conditions.

Any process involving heating to a high temperature will probably result in an oxidized surface unless a nonoxidizing atmosphere is used. In order to remove this surface, a chemical solution is needed, usually either an acid or an electrolytic alkaline process. The acid processes are generally known as *pickling*, and the solutions may or may not contain inhibitors to slow down the reaction rate, or minimize any tendency toward pitting. In the electrolytic processes, the work being cleaned is generally the anode, and therefore the term *anodic cleaning* is usually used. Nonelectrolytic alkaline cleaners are used also extensively but customarily only for the degreasing type of operations.

#### ANNEALING

Annealing is the term most generally used to describe heat-treating processes falling under the first classification. In general, this heat-treatment may have any of six functions:

1. To remove stresses
2. To induce softness
3. To alter strength, ductility, toughness, electrical, magnetic, or other physical or mechanical properties
4. To adjust the grain size
5. To remove gases
6. To produce a definite microstructure

The temperature at which annealing is carried out and the rate of cooling ensuing depend upon the material being heat-treated and the purpose of the heat-treatment. Any of the following specific processes may be called *annealing* in certain industries:

**FULL ANNEALING** The process of full annealing, usually shortened simply to *annealing*, consists of three stages:

1. *Slow heating* to the annealing temperature, to avoid strains produced by thermal gradients arising from differences in section thicknesses and heat penetration.
2. *Soaking* or holding at the annealing temperature to permit uniform

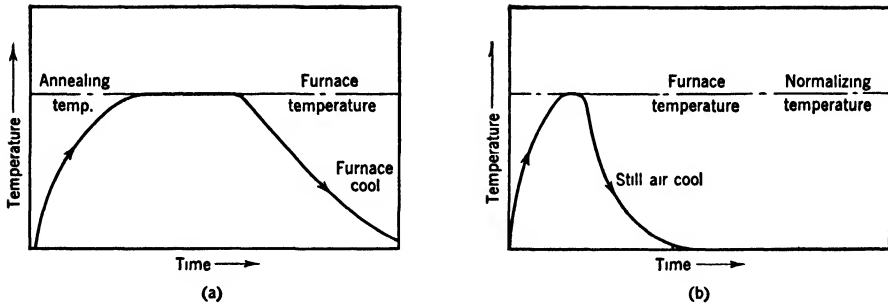


FIGURE 273. Schematic representation of full annealing and normalizing heat-treatments. *a.* Full annealing. *b.* Normalizing.

penetration of heat, for a period of time usually determined by the empirical rule of not less than 1 hr for each inch of thickness of the heaviest section being treated.

3. *Slow cooling*, usually in a furnace or in a protected and insulated container, for the purpose of avoiding cooling strains and permitting any reactions to take place at the highest possible temperature.

The full anneal usually gives the closest approach to equilibrium conditions. Figure 273*a* indicates diagrammatically the cycle of the process. The metal slowly attains the furnace temperature, is held there to ensure uniformity, and then slowly cools, either in the furnace, or, if this would tie up production unnecessarily, in some external container.

For steel, the temperature of full anneal is generally about 100° F (50° C) above the upper limit of the critical temperature range, i.e.,  $A_3$ , or the line *GSK* in Fig. 274.

**NORMALIZING** The process of normalizing, which is used with ferrous materials, consists of heating the piece to a temperature about 100° F (50° C) above the critical temperature range, i.e.,  $A_3$  for hypoeutectoid steel or  $A_{cm}$  for hypereutectoid steel, followed by cooling to below the critical range in still air at ordinary temperature.

The most common reason for normalizing is to adjust mechanical properties, although it is occasionally used to produce a preliminary homogenization of the structure before full annealing. Because of the high temperature to which hypereutectoid steels must be heated for normalizing, their austenitic grain size will usually coarsen, and proeutectoid cementite will precipitate on subsequent cooling, either at the grain boundaries or as needles within the grains. Therefore, these steels are seldom normalized unless it is absolutely necessary; annealing is preferred.

In Fig. 273*b* is shown diagrammatically the cycle most generally used for normalizing and other "mill annealing" processes. The work is brought

up to the normalizing temperature but is not held there, or soaked, for any period of time as in an anneal. Cooling is carried out in still air and is usually at a rate appreciably faster than that used in annealing. The cooling rate, therefore, is the principal difference between normalizing and annealing although it should be clear by now that the shorter time at the normalizing temperature will not tend to give as uniform a structure or properties as would be secured by annealing.

**PROCESS ANNEALING** The term process annealing is used in the ferrous sheet and wire industries, and in many of the nonferrous industries, to designate a treatment in which cold-worked metal is heated above the strain recrystallization temperature in order to produce a recrystallized structure. The rate of cooling following such a process is seldom, if ever, of importance. For iron-base alloys which are essentially ferrite, the preferred temperature is below or close to the lower limit of the critical temperature range for steel, viz., 1000–1200 F (550–650 C). In the nonferrous industries, the actual temperature range may vary within comparatively wide limits, depending upon the alloy being treated and the grain size desired. More specific data will be given later in the discussion of the engineering alloys.

**SOLUTION ANNEALING** With certain alloys, notably those of the precipitation-hardening and corrosion-resisting groups, annealing is carried out at a temperature above the solid solubility line so the significant alloying elements or impurities will dissolve in the matrix solid solution. Such heat-treatments are generally referred to as solution treatments or solution anneals. The temperatures and times used vary with the alloy but they are generally followed by rapid cooling, i.e., at a rate faster than the critical cooling velocity for that alloy, in order to suppress any precipitation that might occur. However, with some precipitation-hardening alloys, the cooling may be controlled at a slower rate to eliminate the need for a subsequent precipitation heat-treatment at a lower temperature.

**STRESS-RELIEF ANNEALING** When metal parts have been subjected to strains, either by cold deformation or by nonuniform cooling from an elevated temperature, unbalanced internal stresses will frequently be found to exist in them. Depending on their nature, these stresses may either increase or decrease the resistance to external loading and they may also lead to

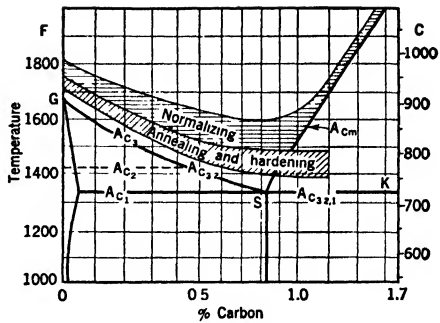


FIGURE 274. Critical-range diagram for iron-carbon alloys, showing normalizing, annealing, and hardening ranges. (After *Metal Progress*, American Society for Metals.)

serious distortion during subsequent machining or heat-treating operations. Thus, their elimination or control is particularly important in welded structures, castings, and cold-worked parts for engineering applications in general.

These internal stresses can either be balanced or else decreased to an insignificant magnitude by suitable heat-treatment. Generally, such stress-relief anneals are carried out in a temperature range just below that required to produce strain recrystallization and for times sufficient to bring the entire part to a uniform temperature. Cooling is carried out sufficiently slowly to maintain reasonable uniformity and to ensure that no additional stresses are introduced from this source.

As a rule, no changes in metallographic structure result from stress-relief annealing but the hardness may increase slightly and the yield strength may rise markedly, to an extent dependent on the alloy and the character of the internal stresses existing before treatment.

**PATENTING** Patenting is used for medium- to high-carbon steel wire, as a prelude to further wire drawing.<sup>27</sup> It consists of heating above the critical temperature range followed by controlled cooling to below that range in air, molten lead, or molten salt, maintained at some temperature in the range 800–1025 F (425–550 C), depending upon the composition of the steel and the properties desired in the finished product. This treatment gives a structure, essentially very fine pearlite, which has a high initial strength, and the best characteristics for drawing to high tensile strength wire. For best results, patenting is carried out continuously as a strand process which probably explains why the transformation takes place *above* rather than *at* the quenching bath temperature. On the basis of the previous discussion, transformation in the range 800–1025 F (425–550 C) would be expected to result in a bainite rather than a fine pearlite structure.

#### AUSTEMPERING

A modern heat-treating process, known as austempering,<sup>28</sup> is somewhat similar in nature to patenting, although it is used to produce quite a different end result. Fundamentally, austempering is the application, on a commercial basis, of the heat-treatment first used by Davenport and Bain to produce bainite, and illustrated schematically in Fig. 251. There is a limiting section size, about  $\frac{1}{4}$  in. for a plain carbon steel, to which the method is restricted because of the necessity of suppressing completely the transformation of austenite to pearlite. However, this limiting section size will vary

<sup>27</sup> See, for example, J. S. G. Primrose, *Trans. A.S.M.*, 13, 1928, 617.

<sup>28</sup> See E. S. Davenport, *Metal Progress*, October, 1939, 375.

widely with composition since it depends on the nature of the actual S-curve for the alloy, i.e., its hardenability.

The material to be treated is first heated above the critical range, usually in a salt bath to restrict oxidation, and then quenched into a bath of molten lead or salt which is held, within the range of the austenite to bainite transformation, at a temperature dependent on the hardness desired. After sufficient time has elapsed for the transformation to bainite to be completed, the material is cooled to room temperature at any rate desired since no further transformation can occur.

The purpose of this treatment is to produce in the steel the combination of toughness and hardness which is unique with the bainite structures (Figs. 256, 257).

#### BRIGHT ANNEALING

Any annealing operation or any process involving high-temperature heating, which is conducted in a nonoxidizing atmosphere, is usually termed a bright anneal.<sup>29</sup> The atmosphere may be steam, water- or producer gas, hydrogen, a hydrocarbon such as propane and butane, or an inert gas, such as nitrogen, depending upon the metal being annealed. Strictly, a bright anneal is one in which no surface oxidation or discoloration occurs during heat-treatment. Steels cannot be bright annealed in steam or in any other atmosphere containing appreciable amounts of water vapor, because such conditions tend to remove carbon from, i.e., *decarburize*, in addition to oxidizing the surface.<sup>30</sup> Decarburization, as illustrated in Fig. 275, proceeds by reactions similar to those discussed in connection with Fig. 86.

If the metal treated is in coils, bright annealing is usually a batch operation, but it may be done continuously, with each strip or strand of metal passing successively through a heating and cooling zone continuously and alone. The process seems to give superior results when run continuously, although the cost may be somewhat greater than in the batch method.

#### QUENCHING

Cooling by immersion, at rates faster than those produced by still air, is usually classified under the general term *quenching*.<sup>31</sup> This is the first

<sup>29</sup> See, for example, A. L. Marshall, *Trans. A.S.M.*, **22**, 1934, 605-619.

<sup>30</sup> See, for example, C. R. Austin, *Trans. A.S.M.*, **22**, 1934, 31-57.

<sup>31</sup> See, for example, I. N. Zavarine, *Metal Progress*, April, 1935, 43-46; Howard Scott, *Trans. A.S.M.*, **22**, 1934, 577-602.

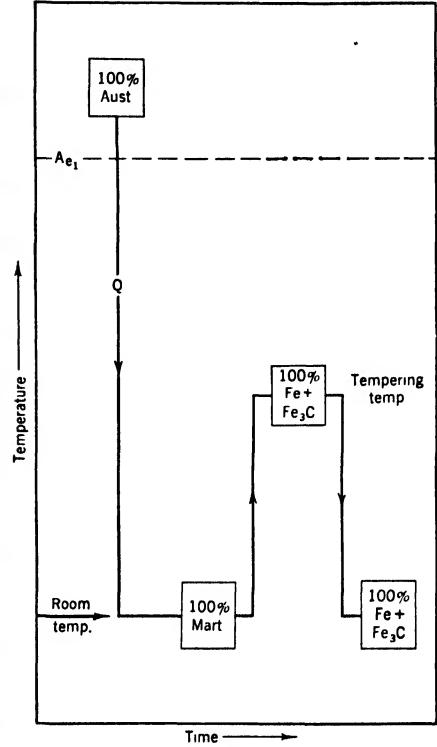


FIGURE 275. (Left) Partially decarburized surface of eutectoid steel resulting from heat-treatment in oxidizing or moist atmospheres. Etched with nital.  $\times 50$ . Note the large amount of free ferrite (white) at the surface exposed to the furnace atmosphere during heat-treatment (top) as compared with the very small amount of it in the protected core (bottom).

FIGURE 276. (Right) Schematic representation of the conventional method of heat-treating an eutectoid or hypereutectoid steel. The steel first is heated above its critical range  $A_1$  ( $A_3$  for a hypoeutectoid steel) in order to make it completely austenitic. It is quenched then into water or oil, depending on the mass and composition, to secure an extremely hard martensitic structure. Finally, the desired structure and mechanical properties can be secured by tempering, i.e., reheating, at the proper temperature between 375 and 1000 F (190 and 540 C). During tempering, control of properties is secured by varying either the temperature or the time or both. The rate of cooling following tempering is not important.

stage in the conventional method of hardening steel by heat-treatment which is shown schematically in Fig. 276.

As a rule, common quenching processes may be subdivided into one of four groups:

1. Air quenching
2. Oil quenching

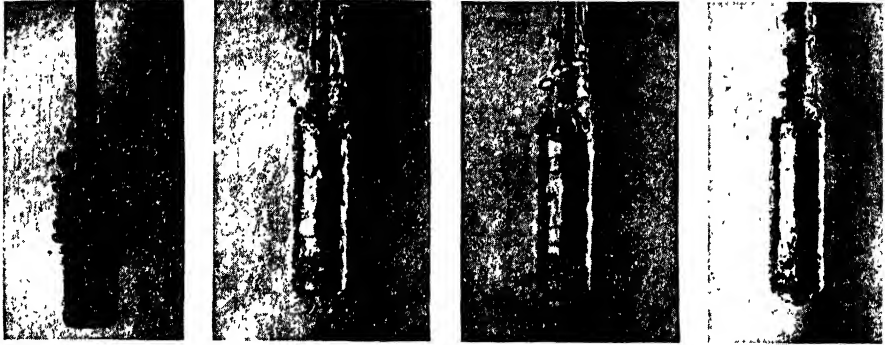


FIGURE 277. High-speed photographs showing various stages in the quenching of a steel cylinder into oil. Left, beginning of quench in transformer oil. Center,  $\frac{1}{2}$  sec and 1 sec after the beginning of quench in Russian oil. Right, 5 sec after the beginning of quench in Russian oil. Bubbles of oil vapor form quickly, but the vapor rapidly becomes a relatively thin layer which limits the rate of heat removal. (From *Technology Review*, courtesy I. N. Zavarine.)

3. Water quenching
4. Brine quenching

In addition, although usually not commercially except as a subsequent operation, such cooling media as liquid air or some similar low temperature liquid may be used.

#### EFFECT OF FILM FORMATION ON QUENCHING

Any gas film furnishes an excellent layer of insulation through which heat passes very slowly. Since, in quenching, it is desired to remove the heat uniformly from the piece being quenched, it is important that this gas film be either produced or broken down almost at will. The rates of quenching in various media are determined by the persistency with which the gas film adheres to the piece being quenched. In an air quench, the air film produced is quite persistent, and is with difficulty broken away. Hence the rate of cooling is generally comparatively slow, and about the only control over the process is given by the velocity of the blast of air. The higher the velocity, the greater the tendency for the air film to break away, and, therefore, the faster the rate of cooling.

In an oil quench, a considerable variation is possible by the use of either animal, vegetable, or mineral oils, or blends of two or more of these varieties. Preheated or precooled oil baths also can be used. The vapor pressure of the oil is particularly important, because this determines, to a great extent, the thickness of the oil vapor film produced on the surface of the piece being quenched. In Fig. 277 is shown a series of pictures indicating



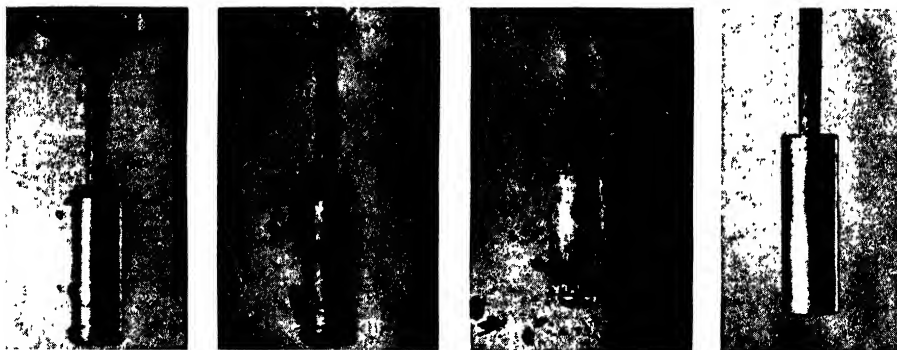


FIGURE 278. High-speed photographs showing various stages in the quenching of a steel cylinder into water. Left, start of 1550 F (840 C) quench. Center, types of reaction taking place within 2 sec after start of quench. Right, appearance of specimen (actually quenched in 5 sec in brine) after quench is complete. Initially, a relatively thin film of steam surrounds the specimen and a few bubbles are given off. As this increases in turbulence the action becomes violent enough to tear off scale, and then gradually ceases as the heat is withdrawn. (From *Technology Review*, courtesy I. N. Zavarine.)

the nature of the film formation during the quenching of a specimen into oil. The range of quenching rates possible by the use of oil is quite broad. Under some conditions rates almost as slow as an air quench are possible, and under other conditions rates almost as fast as a water quench are within the range easily secured.

Although a water quench is usually a rather fast quench, and hence would be used with steel when a martensitic condition was desired, the film formed on the surface of the piece is steam and this is comparatively difficult to break down. Hence, the use of water alone may lead to what are known as *soft spots* or regions in which the rate of cooling is considerably decreased because of the close adherence of a portion of the steam film. If it is possible to break down this steam film readily, water quenching may be quite adequate. Figure 278 shows a series of pictures taken during a water quench, which gives some idea of the persistency of the steam film. By using rapidly flowing streams of water and by agitating the work in the quenching bath, the film is broken down to a considerable extent; but the process is by no means certain since crevices and depressions in the piece may assist the retention of the steam film.

By the addition of about 10% salt to the water-quenching bath, a brine solution is produced which is much more efficient than water as a quenching medium. In Fig. 279 several pictures taken during a brine quench are shown. Apparently, during the formation of the steam film on the surface, crystals of salt, containing water of crystallization, tend to be deposited. As soon as these are formed on the hot surface of the specimen, they

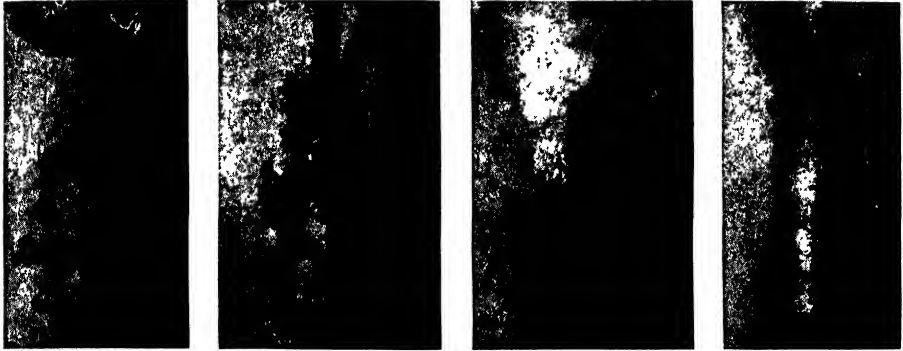


FIGURE 279. High-speed photographs showing various stages in the quenching of a steel cylinder into brine. Left, beginning of quench in 20% sodium chloride solution and in 5% sodium chloride solution. Right, two step quench. Specimen has been dropped to position shown after holding for two intervals of less than  $\frac{1}{4}$  sec in a higher position above the field of the photograph. Note the distinctive action which occurs in brine or caustic solutions. A cloud of salt crystals is thrown away from the surface with almost explosive violence. This effectively breaks down any films which have been formed. (From *Technology Review*, courtesy I. N. Zavarine.)

practically explode because of the rapid evolution of the water of crystallization and its transformation into steam. The explosion of these crystals serves very efficiently to break away the steam film from the surface, and, therefore, permits actual contact of the liquid and the specimen with an accompanying rapid removal of heat.

#### INTERRUPTED QUENCHING

Certain methods of interrupted quenching, notably *time quenching* and *martempering* have recently been developed and seem to have interesting commercial possibilities. Although they are actually modifications of the basic austempering process their function is fundamentally different.

In time quenching<sup>32</sup> the piece may be:

1. Immersed in water for a definite period of time and then allowed to cool in air or else transferred to an oil bath to complete the quench.
2. Immersed in water for a definite time, removed and held in air for a definite time, and then returned to the water bath to complete the quench.

The purpose of such treatment, of course, is first to cool the specimen quickly to a temperature below the knee of the S-curve, thus retaining austenite, and then to allow it to cool more slowly so portions of it may transform to bainite as well as to martensite. By this means combinations of mechanical properties can be secured which would not otherwise be

<sup>32</sup> See J. L. Burns and V. Brown, *Trans. A.S.M.*, 28, 1940, 209-229.

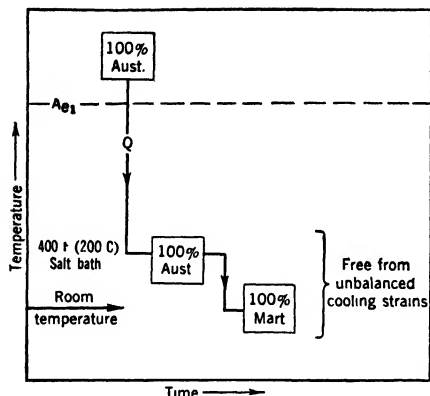


FIGURE 280. Schematic representation of the interrupted quenching process of *martempering*. The steel is quenched from above its critical range into a salt bath held at the temperature of greatest sub-critical austenite stability (cf. Fig. 253). When the temperature has equalized, air cooling to room temperature will effect complete strain-free transformation to martensite.

enced by the rapidity of the quench, so the piece could then be made completely martensitic merely by cooling it from the salt bath to as low a temperature as was necessary. By this means the high thermal strains were eliminated leaving in the piece only those unavoidable strains resulting directly from the austenite to martensite transformation. Full martensitic hardnesses can thus be secured with a greatly decreased danger of cracking or distortion.

#### EFFECT OF COOLING RATE UPON STRUCTURE AND UPON OTHER CHARACTERISTICS

Strictly, relationships between cooling rate and structure can be made satisfactorily only for specimens which cool essentially uniformly throughout the entire section. Only in oil quenching are the differences marked, however. In general, when dealing with relatively thin sections, cooling in the furnace or in still air may be classified as a slow rate of cooling; air and oil quenching as intermediate rates of cooling; and water and brine quenching as rapid rates of cooling. The first two would, therefore, tend to lead to a pearlitic structure in steel, varying from coarse to fine. The second two

<sup>33</sup> Complete details can be secured from the E. F. Houghton Co., Philadelphia, Pa.

<sup>34</sup> See A. B. Greninger, *Trans. A.S.M.*, 30, 1942, 1-26.

obtainable. The dimensions and shape of the piece, of course, will determine how deeply these structural effects will penetrate.

Martempering<sup>33</sup> is a somewhat similar process, as indicated schematically in Fig. 280, which was placed on a practical commercial basis by the development of a molten salt bath which would cool the piece rapidly to a temperature of 400-500 F (200-250 C), at which metastable austenite can remain longest without starting to transform, and hold it there in the austenitic form until the thermal quenching strains had been essentially relieved. It has already been shown<sup>34</sup> that the temperature of formation of martensite was not influ-

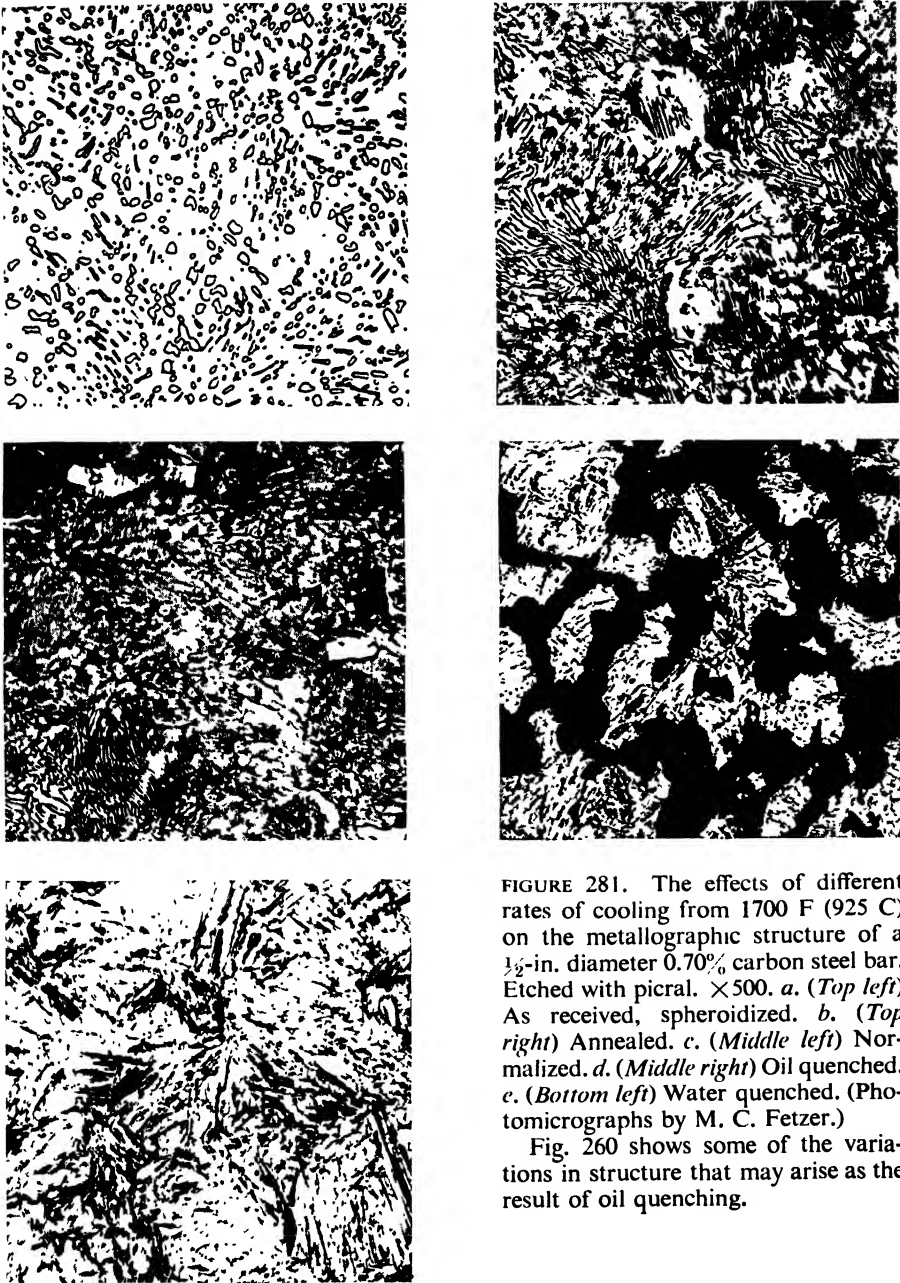


FIGURE 281. The effects of different rates of cooling from 1700 F (925 C) on the metallographic structure of a  $\frac{1}{2}$ -in. diameter 0.70% carbon steel bar. Etched with picral.  $\times 500$ . *a.* (Top left) As received, spheroidized. *b.* (Top right) Annealed. *c.* (Middle left) Normalized. *d.* (Middle right) Oil quenched. *e.* (Bottom left) Water quenched. (Photomicrographs by M. C. Fetzer.)

Fig. 260 shows some of the variations in structure that may arise as the result of oil quenching.

probably would result in a pearlitic structure varying from fine to very fine or nodular, with the possibility of producing some martensite near the faster end of the range. The water and brine quench almost invariably will

tend to exceed the critical cooling rate in a plain carbon steel with a relatively thin section, and, therefore, should result in an almost completely martensitic structure. The effects of cooling rate on the structure of a 0.70% carbon steel with a  $\frac{1}{2}$ -in. section are illustrated in Fig. 281.

The structure produced by cooling or by quenching also depends, of course, upon the shape and the diameter or the mass of the piece being quenched, since, obviously, a balance is being reached between two opposing tendencies. On the one hand is the tendency of the austenite to transform to pearlite, a reaction which will proceed at a more or less definite rate, depending upon the temperature. Opposing this is the tendency for the heat to flow from the specimen being quenched to the quenching medium, and this is again controlled, to a certain extent, by the surface and the temperature of the piece. The greater the mass of the piece the greater will be the amount of heat to be removed, and hence the slower will be the cooling rate for a given quench.

If the critical cooling velocity is exceeded throughout, the piece will become entirely martensitic, but the actual quenching that is required to produce this structure depends upon the rate of transformation of the alloy rather than the particular medium involved. In other words, a steel that transforms very slowly can be made completely martensitic by an air quench, whereas one that transforms very rapidly might require a brine quench or an even faster rate of cooling in order to achieve the same result. Likewise, a small enough section might become martensitic with an air quench, whereas a heavy section of the same steel might not harden throughout in a brine quench.

As a rule, the more rapid the rate of cooling used, the greater are the internal stresses produced inside the piece being quenched. This is almost invariably true, even when the section is quite symmetrical, simply because the entire piece cannot be introduced into the quenching medium at exactly the same instant. There always must be some time lag. For this reason, the direction in which a given section is quenched may be extremely important when possible internal stresses are considered. For instance, if a regular cylinder is quenched, the stresses are much less harmful when it enters the quenching bath vertically than they are when it enters the quenching bath horizontally.

In addition, the surface always will cool more rapidly than the interior, thereby setting up thermal strain gradients. As a rule, the portion that cools more rapidly will retain compressive stresses, whereas the portion that cools more slowly will contain residual tensile stresses.<sup>35</sup>

<sup>35</sup> See, for example, G. Sachs and K. R. Van Horn, Chap. V in Ref. 11, at end of this chapter.

## HARDENABILITY

The most important objective in the commercial heat-treatment of steel is to harden in a controlled manner to whatever depth is desired, and frequently, to harden throughout. In order to do this in the optimum manner, the mildest possible quenching bath should be used in order to keep the quenching stresses to a minimum. Hence, it is very important to know, or at least to have some idea of, the severity of quench that is required. Information of this sort is secured by determining the hardenability or *reaction to heat-treatment* of the steel. This can be determined in a number of different ways, although the issuance of A.S.T.M. Tentative Standard A255-T is an effort toward achieving uniformity. Essentially all the methods depend on evaluating two factors: (a) the austenitic grain size for a given prequenching or hardening temperature; and (b) the tendency of austenite of a particular composition to transform.

The effect of grain size, as illustrated in Fig. 282, already has been mentioned in the discussion of the S-curve. A coarse grain size tends to shift the S-curve to the right, indicating thereby a decreased tendency to initiate the transformation of the austenite to pearlite or, conversely, an increased tendency for the austenite to transform to martensite. Obviously, the greater the tendency to transform to martensite, or the greater the amount of time available for cooling below the knee of the S-curve, the greater will be the hardness penetration. Knowledge concerning the factors

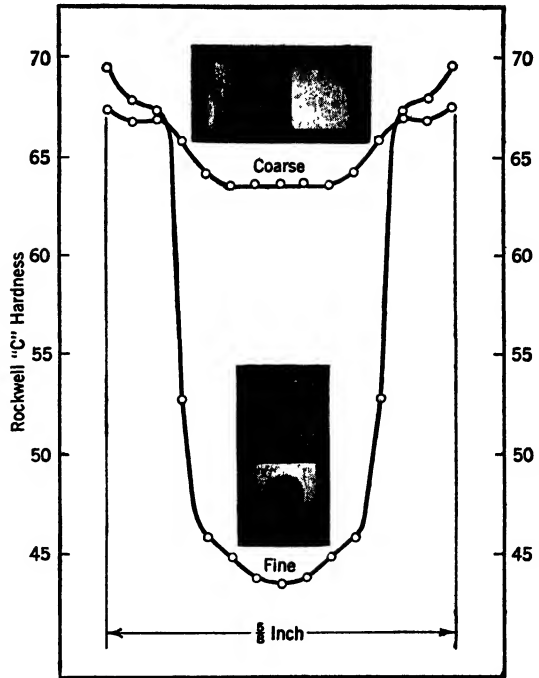


FIGURE 282. Hardness distribution across two  $\frac{5}{8}$ -in. specimens of a single steel as affected by coarsening treatment. G.S. of 5 (coarse) in the deep-hardened specimen established at 1800 F (980 C); G.S. of 8 (fine) in shallow-hardened specimen established at 1550 F (840 C); both quenched from 1375 F (745 C). (Courtesy U.S. Steel Corporation Research Laboratory, Kearny, N. J.) Cf. Fig. 265.

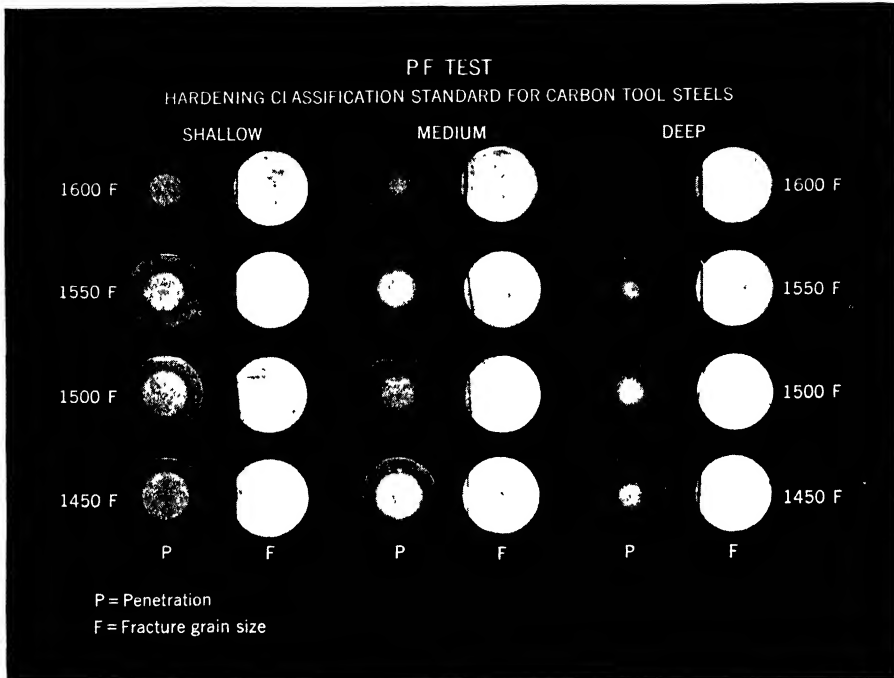


FIGURE 283. Penetration specimens and fractures from P-F tests on shallow-, medium-, and deep-hardening carbon tool steels. (From *Bethlehem Tool Steels*, courtesy Bethlehem Steel Company.)

affecting the tendency of the austenite within the grains to transform to pearlite, in contradistinction to the effect of the grain boundaries in initiating the transformation, is so incomplete that actual experimental study by one of the methods given below is still usually to be preferred.

**THE SHEPHERD P-F TEST** One of the earliest methods developed was the *Shepherd P-F test*<sup>36</sup> which is made upon a 3/4-in. diameter bar 3 in. long. A specimen is heated to each of four temperatures: 1450 F, 1500 F, 1550 F, and 1600 F (790, 815, 845, and 870 C), and brine quenched in a specified manner. Each of these test bars is then notched and fractured; and the penetration of hardness, as judged by the thickness of the martensitic zone in a ground and etched specimen is measured to the nearest 1/64 in. The grain size of the fractured piece is also measured by comparison with an arbitrary set of standards, and the hardenability of the piece judged by a factor which depends upon the penetration, *P*, and the fracture grain size, *F*, at each temperature. Figure 283 shows the appearance of typical penetration and fracture specimens.

**THE CRITICAL DIAMETER** From any given steel a series of specimens

<sup>36</sup>See B. F. Shepherd, *Trans. A.S.M.*, 22, 1934, 979-1000.

can be made up having a range of diameters. Each of these can then be quenched in a given quenching medium, and the diameter which just hardens through to the center, i.e., hardens to 50% martensite-50% pearlite by definition, determined by trial and error. A plot of depth penetration vs. diameter, similar to that in Fig. 284, will then give the *critical diameter*,<sup>37</sup> the maximum diameter that can be hardened for a given quenching bath. For comparison or for use with pieces actually being quenched, such as a gear, for example, the rate of cooling at the center of each of

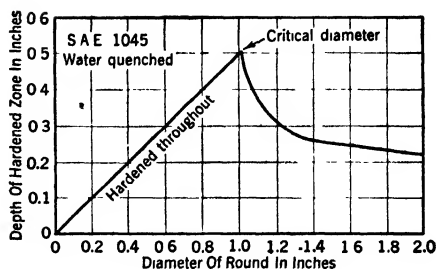


FIGURE 284. The hardenability of a 0.45% carbon steel, S.A.E. 1045, as indicated by a plot of the thickness of the hardened exterior rim, after a vigorous water quench, against the diameter of round, and illustrating the significance of the *critical diameter*. (After M. A. Grossman, courtesy American Society for Metals.)

these test pieces can be measured by the use of a thermocouple inserted into its center, and the critical cooling rate for this section of the material thus determined. The critical cooling rate for the important section of the piece being heat-treated can similarly be determined by quenching a trial specimen with a thermocouple inserted in the desired position. Comparison of the two sets of data then will show which rate of cooling must be used to harden the desired specimen completely.

**THE CARPENTER TAPERED TLST BAR** A modification of this general process has been suggested by the Carpenter Steel Company.<sup>38</sup> They propose the use of a tapered-cone test bar which can be quenched by immersion, and then sectioned longitudinally, thus securing in one test the information which would otherwise require a whole series of specimens. Such test bars, with the information that can be secured for them, are illustrated in Fig. 285.

**THE JOMINY END QUENCH TEST** Another type of gradient test is the one proposed by Jominy,<sup>39</sup> in which a bar of definite dimensions is taken, heated to a definite temperature, and then quenched by water impinging against one end with a definite velocity (Fig. 286). The hardness penetration can then be measured and compared with the known rates of cooling of points at various distances from this end. These rates can be secured either by placing a thermocouple at various positions along the bar, or by

<sup>37</sup> See also M. A. Grossman, M. Asimow, and S. F. Urban, Ref. 9, pp. 124-196, at the end of this chapter.

<sup>38</sup> See C. B. Post, O. V. Greene, and W. H. Fenstermacher, *Trans. A.S.M.*, **30**, 1942, 1202-1247.

<sup>39</sup> See, for example, W. E. Jominy and A. L. Boegehold, *Trans. A.S.M.*, **26**, 1938, 574; and W. E. Jominy, Ref. 9, pp. 66-94, at the end of this chapter.



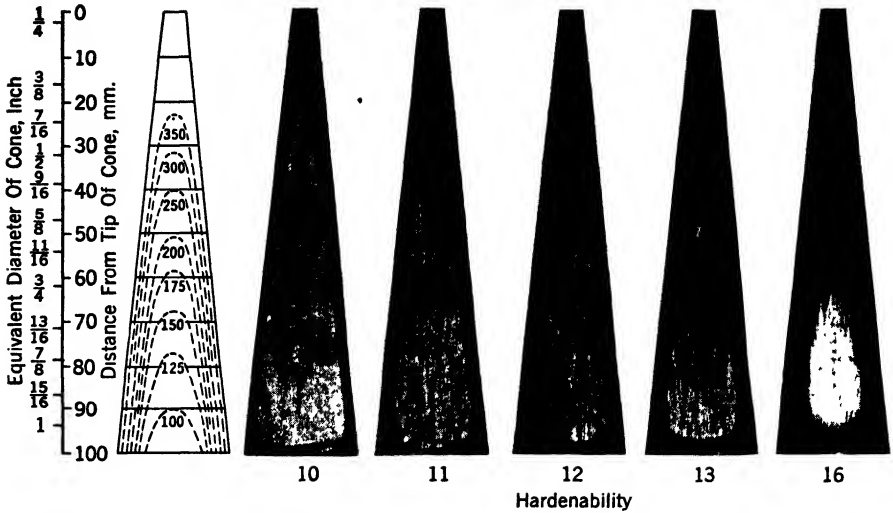


FIGURE 285. Longitudinal sections of tapered-cone hardenability bars after light etching to show the hardness penetration (dark); and drawing of longitudinal section of a specimen brine quenched from 1450 F (790 C) showing loci of points which cool at equal rates (as measured in deg F per sec at 1300 F) and the penetration that could be expected in cylinders of various equivalent diameters, i.e., whose radius is equal to the perpendicular distance from the given point on the central axis of the cone to its surface. (Courtesy The Carpenter Steel Company.)

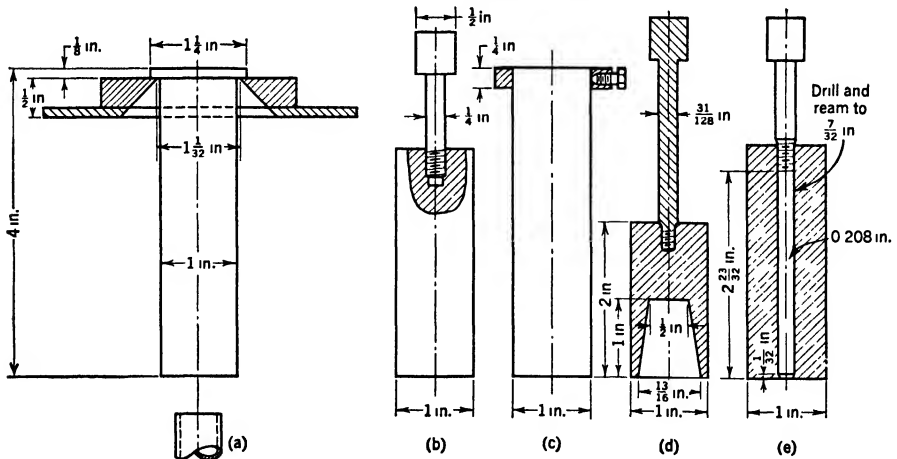


FIGURE 286. Various types of test bars used in the end-quench or Jominy hardenability test. *a*. Preferred test specimen, showing also a schematic representation of a holding jig and quenching orifice. *b*, *c*. Optional types of standard bar. *d*. Drilled bar specimen for shallow-hardening steels. *e*. Drilled bar specimen for steel available only in small sizes. (After A.S.T.M. Tentative Standard A255-T.)

comparing the hardness or the metallographic structures in the end-quenched bar with those in specimens of varying diameters whose cooling rate has been determined by the methods already mentioned.

Under certain conditions, especially when the steels are comparatively shallow hardening, i.e., when the rate of transformation is comparatively fast for the given quenching medium, some modification of the usual Jominy bar is desirable; and the use of the L-bar,<sup>40</sup> shown in Fig. 286*d*, is recommended. The Jominy test is used extensively today for determining the hardenabilities of commercial steels.

#### EFFECTS OF ALLOYING ELEMENTS ON HARDENABILITY

The effects of small amounts of some of the various alloying elements, generally found in alloy steels, upon the hardenability, as evaluated by M. A. Grossman, are shown in Fig. 287.<sup>41</sup> These effects are not additive but are compound, i.e., they multiply rather than add. Several other methods may be used to estimate the quantitative effects of various elements on hardenability,<sup>42</sup> and this is just one.

In using these multiplying factors, the diameter of a standard bar of a given chemical composition which will harden completely through with an ideal quench is taken as a base, e.g., 1 in. This is the hardenability due to the carbon content alone (a pure iron-carbon alloy). If, then, 0.3% of some other element, say chromium, is added to the standard composition, the diameter of 1 in. should be multiplied by the factor for 0.3% chromium, which is 1.7, and the resulting alloy, therefore, will harden completely through in a bar 1.7 in. in diameter, i.e.,  $1.7 \times 1$ . Similarly the effect of every alloying element present, including the so-called incidental

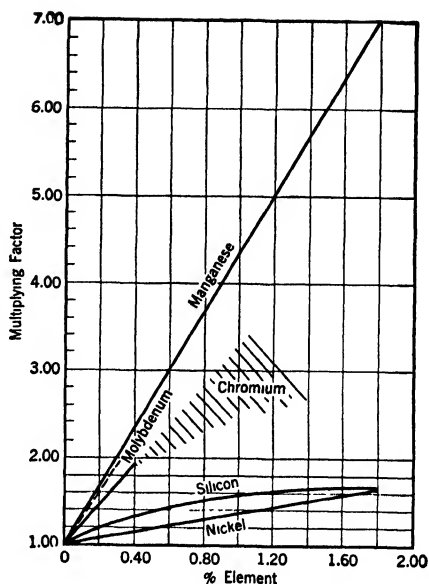


FIGURE 287. Assembly of multiplying factors representing the effects of varying alloying elements upon hardenability. (From M. A. Grossman, *Trans. A.I.M.E.*, 150, 1942, 227-259.)

<sup>40</sup> See W. E. Jominy, *Trans. A.S.M.*, 27, 1939, 1072-1085.

<sup>41</sup> See M. A. Grossman, *A.I.M.E. Tech. Pub. No. 1437*, 1942, 1-29 (*Metals Technology*, June 1942).

<sup>42</sup> See, for example, J. L. Burns, T. L. Moore, and R. S. Archer, *Trans. A.S.M.*, 26, 1938, 1; J. L. Burns and G. C. Riegel, Ref. 9, pp. 262-301, at the end of this chapter.

elements which are usually considered only as impurities, must be evaluated, and the effects multiplied together to give the diameter of the bar of that composition which will harden completely through. In making a determination of hardenability using this method not only the complete chemical analysis but also the "as-quenched" grain size characteristic of the steel must be known. Naturally, considerable experience and study are necessary before the method can be applied successfully.

It is to be noted that in the low percentage ranges, a given increment is more effective than it would be in the high percentage ranges. For this reason, equivalent hardenabilities can much more readily be produced by adding small amounts of several alloying elements than they can be by adding comparatively large amounts of only one or two. This fact was extremely important in the conservation of critical alloying elements by the development of the so-called National Emergency Steels during the period of World War II.

#### REHEATING OR TEMPERING

Heat-treating processes in which the metal is reheated to definite temperatures for definite periods of time, in order to produce a more or less definite atomic mobility, are usually termed *tempering*, *drawing*, *aging*, or *precipitation treatments* depending upon the particular type of alloy that is being treated and the temperature range that is used. Their purpose is always more or less the same. An alloy which is in an unstable or a partially stable condition is heated to a definite temperature range to permit it to approach the stable state in a controllable manner. A low enough temperature is selected so that the desired result can be secured in a reasonable time without danger of overshooting. The final stage in the conventional method of hardening steel by heat-treatment, which was shown schematically in Fig. 276, is a tempering or drawing treatment.

#### *For Further Study Refer to*

1. *Metals Handbook*: American Society for Metals, Cleveland, Ohio, 1939 (usually published triennially). A new edition will appear in 1948.
2. *The Alloying Elements in Steel*, by E. C. Bain: American Society for Metals, Cleveland, Ohio, 1939.
3. *The Making, Shaping, and Treating of Steel*, 5th ed., by J. M. Camp and C. B. Francis: Carnegie-Illinois Steel Corp, Pittsburgh, Pa., 1940.
4. *The Metallography and Heat Treatment of Iron and Steel*, 4th ed., by A. Sauveur: University Press, Cambridge, Mass., 1935.

5. *Metallographic Technique for Steel*, by J. R. Vilella: American Society for Metals, Cleveland, Ohio, 1937.
6. *Introduction to the Study of Heat Treatment of Metallurgical Products*, by A. Portevin: Penton Publishing Co., Cleveland, Ohio, 1939.
7. *The Working, Heat Treating, and Welding of Steel*, 2d ed., by H. L. Campbell: John Wiley & Sons, Inc., New York, 1940.
8. *Metals*, by Sir Harold Carpenter and J. W. Robertson: Oxford University Press, London and New York, 1939.
9. *Symposium on Hardenability of Alloy Steels*: American Society for Metals, Cleveland, Ohio, 1938.
10. *Quenching of Steels*, by H. J. French: American Society for Metals, Cleveland, Ohio, 1930.
11. *Practical Metallurgy*, by G. Sachs and K. R. Van Horn: American Society for Metals, Cleveland, Ohio, 1940.
12. *Steel and Its Heat Treatment*, 4th ed., by D. K. Bullens: John Wiley & Sons, Inc., New York, 1938.
13. *Symposium on Age Hardening of Metals*: American Society for Metals, Cleveland, Ohio, 1939.
14. *S.A.E. Handbook*: Society for Automotive Engineers, New York, (usually published annually).
15. *Ferrous Metallurgy*, by E. J. Teichert: McGraw-Hill Book Company, Inc., New York, 1944.
16. *U.S.S. Carilloy Steels*: Carnegie-Illinois Steel Corp, Pittsburgh, Pa., 1938.
17. *Republic Alloy Steels*: Republic Steel Corp., Cleveland, Ohio, 1938.
18. *Bethlehem Alloy Steels*: Bethlehem Steel Co., Bethlehem, Pa., 1935.
19. *Metal Progress*: American Society for Metals, Cleveland, Ohio (published monthly).
20. *Transactions American Society for Metals*: A.S.M., Cleveland, Ohio (published annually).
21. *Transactions American Institute of Mining and Metallurgical Engineers, Iron and Steel, and Institute of Metals Divisions*: A.I.M.E., New York (published annually).

# Shaping and Forming the Metallic Materials

## METHODS OF SHAPING AND FORMING

ANY OF THE GENERAL METHODS INDICATED BELOW MAY BE USED for shaping or forming the metallic materials, depending upon the characteristics of the material, the dimensional accuracy required, and the expense permitted.

1. *Casting*, while liquid, into molds, sometimes under an external pressure.
2. *Extruding*, while in a very plastic condition, at a suitable temperature which may be either just below the melting range, or, with some metals, close to room temperature. The properties of the metal or alloy are the determining factor.
3. *Working*, hot or cold, by rolling, forging, heading, piercing, drawing, extruding, cupping, forming, spinning, or other processes, and including the methods of powder metallurgy.
4. *Adding or joining metal* by means of soldering, brazing, welding, riveting, or similar methods.
5. *Removing metal* by methods such as flame cutting, machining, or grinding.

### *Casting While Liquid*

Several methods of forming or shaping liquid metal are commonly used in industry. The most important of these are:

1. *Gravity casting* into sand, semipermanent, or permanent molds with little or no added pressure.
2. *Centrifugal casting*, actually a form of pressure casting using centrifugal force to produce the pressure.
3. *Direct casting* of rod or sheet by any of several processes which have been developed recently, but whose use is still limited.
4. *Die or pressure casting* into closed metal dies under positive pressure.

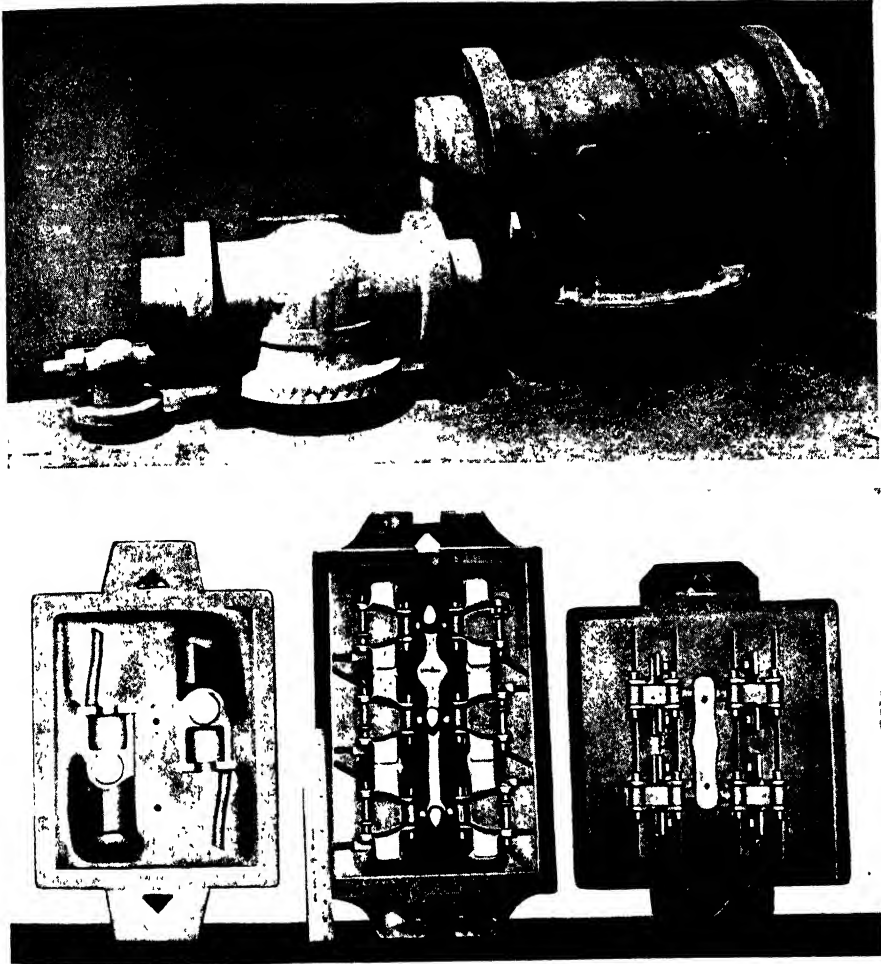


FIGURE 288. Patterns typical of those used for making casting molds.  
a. (Upper) Single loose, wood patterns for valve bodies.  
b. (Lower) Metal match-plate patterns.

Each of these methods has, of course, certain materials, shapes, and applications to which it is best suited.

There is an essential difference between a *casting* and an *ingot*, even though, in both, metal is cast liquid into molds and solidified. Once solid, the casting is in essentially its final shape and usually requires only a relatively few machining operations to finish it. The ingot, on the other hand, is intended for reworking and, when first cast, has only started the processing to its final shape and use.

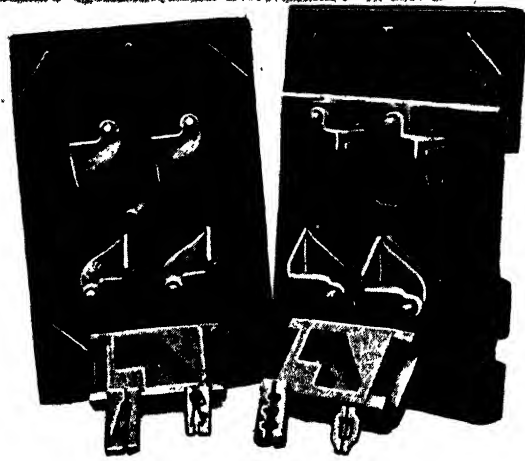
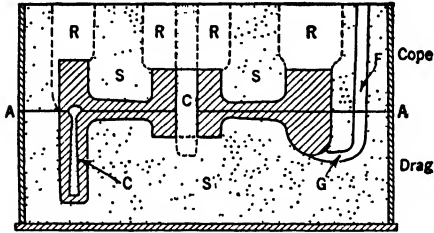


FIGURE 288 (continued) c. Wood and metal cope and drag patterns for freight car hinge butts. (From *Steel Castings Handbook*, courtesy Steel Founders' Society of America.)



CASTING WITHOUT  
ADDED PRESSURE

Castings are most frequently made in a *foundry* by pouring liquid metal into a mold and allowing it to solidify. Generally the piece to be cast is first made in the form of a *pattern*. These patterns may be of several different types, some of which are shown in Fig. 288, depending on the casting and the metal being cast,

FIGURE 289. Schematic representation of the composite parts of a mold. AA, parting; R, riser or feed head; C, core; F, runner; G, gate; S, molding sand. (From *Steel Castings Handbook*, courtesy Steel Founders' Society of America.)

and may be made either of wood or metal depending upon the number of times they are to be used. Around this pattern is constructed a *mold* (Figs. 289, 290) which is usually made in two parts: (a) the top or *cope*, and (b) the bottom or *drag*. Additional joints may be required for more complex castings.

The mold, as a rule, is made of sand, either green or dried, and is used only once, a new mold being made for each casting. Also used are semi-permanent molds and molds made of materials like plaster of Paris, cement, and concrete, which can be used for several castings; and permanent molds, made entirely of metal, which can be used almost indefinitely. The number of castings to be produced will, of course, determine the type of

pattern and mold that is used, in most cases, although there are other factors to be considered.

Internal cavities are taken care of by the use of *cores* which are usually made of sand, and are dried and baked to increase their strength. In some castings, these may be fairly large and complex and must be placed and maintained in position very accurately (Fig. 290) if proper wall thicknesses are to be secured.

Foundrymen must take into consideration several metallurgical factors, the effects of many of which can be minimized by proper design of either the casting or the pattern.<sup>1</sup>

#### MELTING CONDITIONS

The solubility of gases in most metals and alloys increases with temperature, as already illustrated for hydrogen in Fig. 147. When these liquid metals solidify the dissolved gases are released relatively suddenly because they have a much lower solubility in the solid than in the liquid metal. This fact must be considered in all casting work, because, unless the gases are able to escape, they will be entrapped in the solid metal, resulting in internal unsoundness and porosity. Only a few of the means of dealing with gases can be mentioned here.

To prevent the solution of excessive amounts of gases, the melting temperature should be controlled and kept in a range which is just high enough to give the required fluidity. The molten metal, furthermore, should be degasified before casting by treating it with addition agents which will convert the dissolved gas to a solid or to a soluble liquid form, and thereby minimize or eliminate gas evolution during solidification. The mold should be so designed that the casting will cool at a sufficiently slow rate to permit the gases to be given off. There must also be proper venting of the molds not only to permit the liberated gases to escape, but also to prevent the solidifying metal from "pulling a partial vacuum" as its volume decreases and thus, possibly, causing the mold to collapse under external atmospheric pressures.<sup>2</sup>

Molten metal, preferably of controlled temperature, is fed into the mold at the proper pouring speed through one or more openings called *gates*, the placing of which is very important if sound castings are to result. This is illustrated for an aluminum alloy casting in Fig. 291. The rate of solidification and cooling of the various parts of a casting will depend largely on

<sup>1</sup> See, for example, N. F. Hindle, *Metals and Alloys*, 17, 1943, 770-775, 970-977.

<sup>2</sup> See, for example, H. F. Taylor and E. A. Rominski, *Foundry*, 70, 1942, 74-77, 161-164.



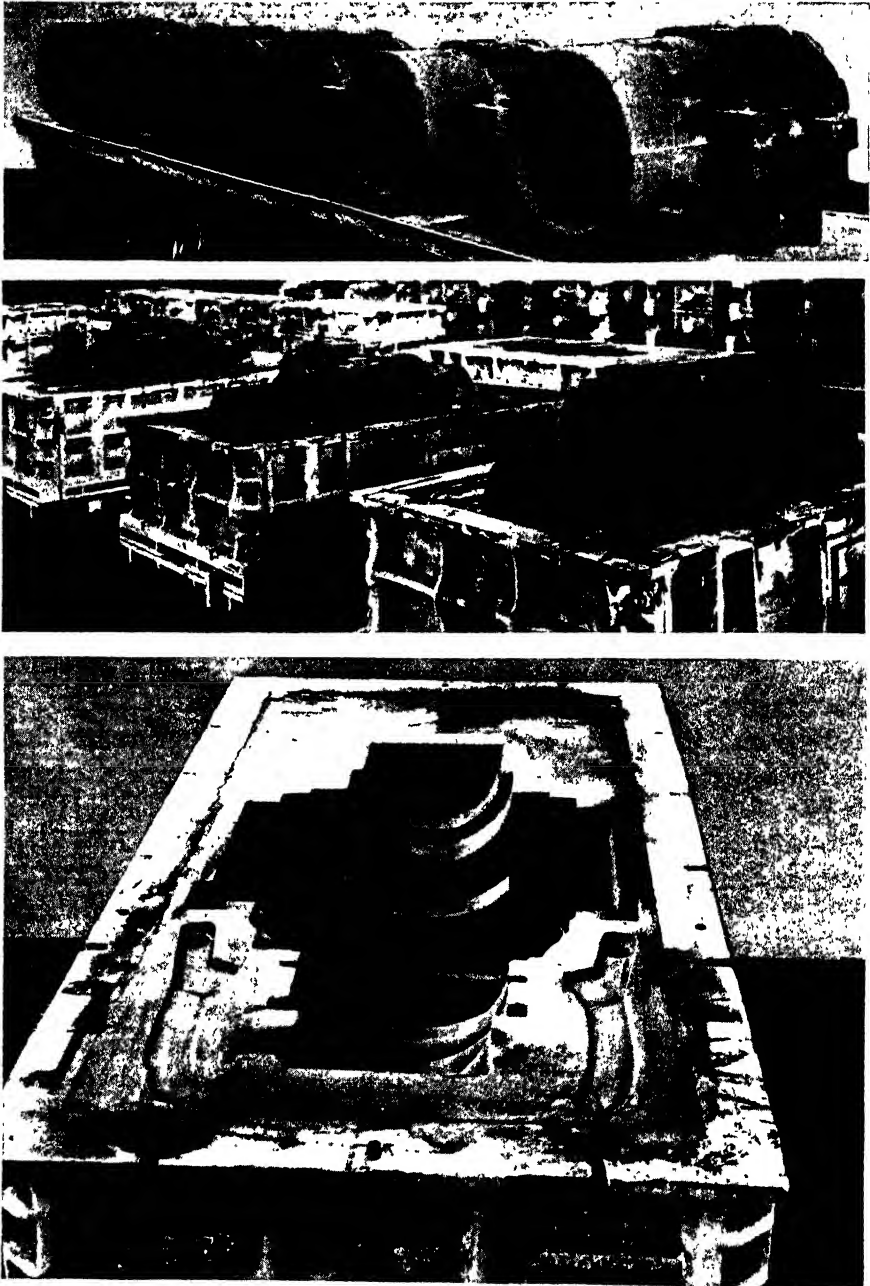


FIGURE 290. A mold construction for Diesel engine cylinders ready for assembly. *a.* (Top) Jacket cores. *b.* (Middle) Floor of molds with cores in place. *c.* (Bottom) A Drag mold showing method of gating. (Courtesy *The Foundry* and American Laundry Machine Co., Rochester, N. Y.)

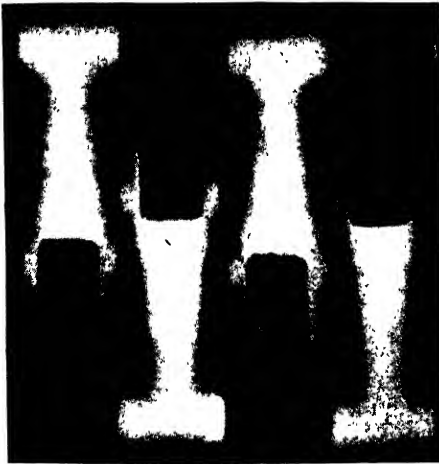
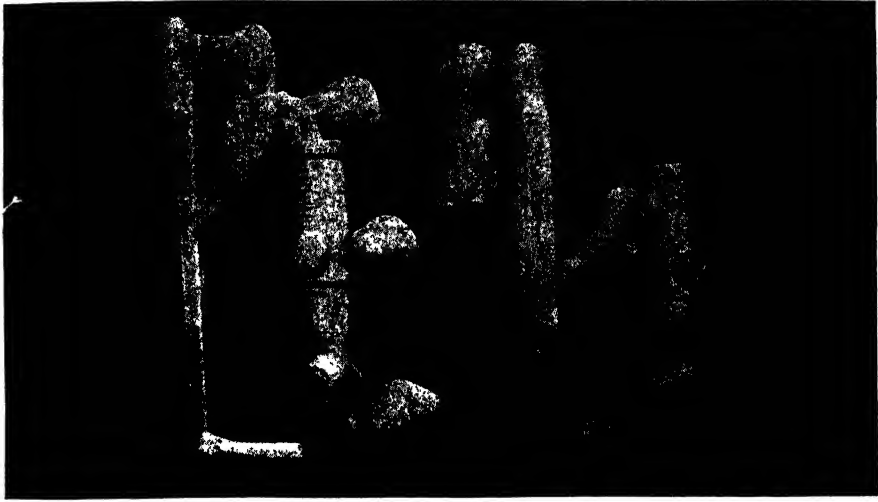


FIGURE 291. The effect of two different methods of gating on the soundness of an aluminum alloy sand casting as revealed by radiographic examination.  
*a. (Upper)* Casting with satisfactory (*left*) and inferior (*right*) gating.  
*b. (Lower left)* Radiograph of satisfactory castings.  
*c. (Lower right)* Radiograph of inferior castings.  
 (Courtesy Aluminum Company of America.)

their cross section, thinner sections tending to cool more rapidly than heavier ones. Hence care must be taken that a section is not separated from its riser by a thin section. Although thin sections are often superheated by gating the mold through them and thus obtaining more uniform freezing conditions, it is definitely preferable to have "section uniformity" wherever possible.

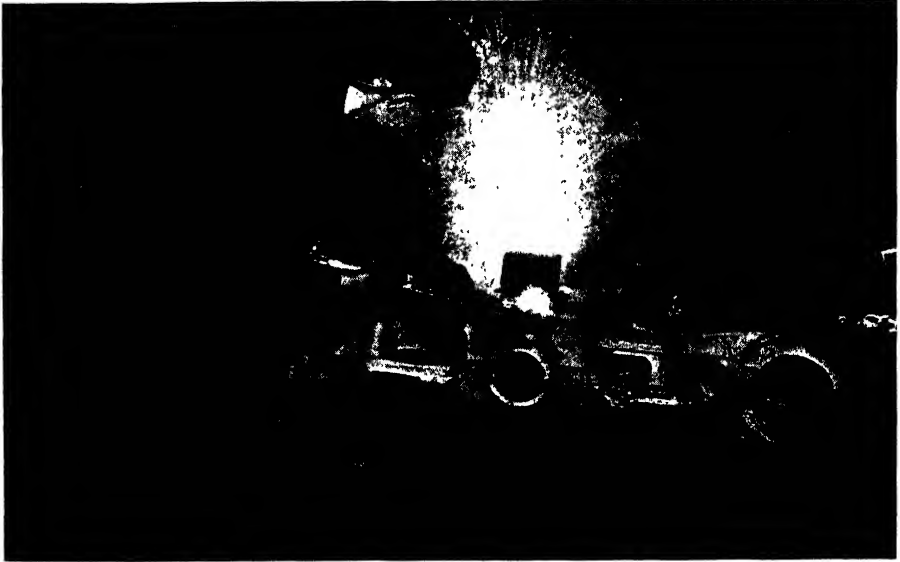


FIGURE 292. Removing feed heads and gates from a steel casting by use of a torch. (Courtesy *The Foundry*.)

The shrinkage of the metal as it freezes can be compensated for to some extent by proper use of gates, and also by using *risers* or *feed heads* through which the molten metal rises as the mold is filled. Because of their comparatively large sections these parts solidify relatively slowly. They thus serve as reservoirs, later removed from the finished casting, from which molten metal can flow to fill up the casting as it shrinks. The placing of the gates and risers is also quite important as the points farthest from them should solidify first, with solidification then progressing toward the feeding points in as regular a manner as possible. The appearance of a casting as it is first removed from the sand with the feed heads and gates still on it can be seen in Figs. 291 and 292.

In addition to the shrinkage as the metal changes from the liquid to the solid state, there is a further dimensional change during cooling because of thermal contraction. This must be allowed for in making the pattern, which can usually, therefore, serve for only one type of metal since different metals both shrink and contract different amounts.

The increase in viscosity of the molten metal on cooling is rapid. Therefore, very thin sections are difficult to cast and fill before the metal viscosity increases too much. Roughly,  $\frac{1}{8}$  in. is the thinnest section that can be cast with aluminum alloys and cast iron, with about  $\frac{3}{16}$  in. for steel, and  $\frac{3}{32}$  in. for brass and bronze.

## FORMATION OF CRYSTALS DURING SOLIDIFICATION

As the casting or ingot solidifies its heat content is, of necessity, dissipated through the walls of the mold. Consequently, it is primarily at these points that crystallization begins, especially if the rate of cooling is relatively slow. The crystals so started tend to grow perpendicular to the surface. When this occurs at a sharp corner a plane of weakness tends to form where the crystals growing in from the two surfaces intersect. Along such planes, cracks are easily started for either of two principal reasons, neither of which implies an inherent weakness of grain boundaries as such:

1. These zones will be the last to freeze, and hence the tensile forces resulting from thermal shrinkage may tend to pull them apart while they are still molten.
2. The solidification shrinkage may be concentrated there in sufficient magnitude to cause a fracture.

By rounding or filleting the corners this difficulty can be largely overcome at the mold surface (Fig. 293) although it may persist in the interior.

When the thermal conductivity of the mold is relatively high or when alloy additions favor the formation of nuclei, many small equiaxed crystals tend to form, rather than large columnar grains. Intermediate states between these two extremes also occur, as illustrated in Fig. 293 for steel ingots and copper wire-bars and billets.

## DISTORTION

Inasmuch as two sections, one heavy and one thin, will cool at different rates, stresses will tend to be set up between them. If these contraction stresses are large enough they may cause the casting to crack or fracture in that region, as shown in Fig. 294. Even if cracking or tearing does not occur, these high internal stresses, unless they can be subsequently relieved by suitable thermal or mechanical treatment, will modify the safe external load under which the casting can be used. However, since the stresses at the surface may be either compressive or tensile, depending on both the section and the adjoining contour (convex or concave, respectively), the casting may be either stronger or weaker with respect to the external loading. In relieving such stresses, severe distortion or warping may result, both serious defects in a casting. Fortunately, in the complete casting the stresses are usually balanced, so warpage seldom occurs prior to machining or removal of gates and risers.

In correct casting design the section thicknesses should change gradually,

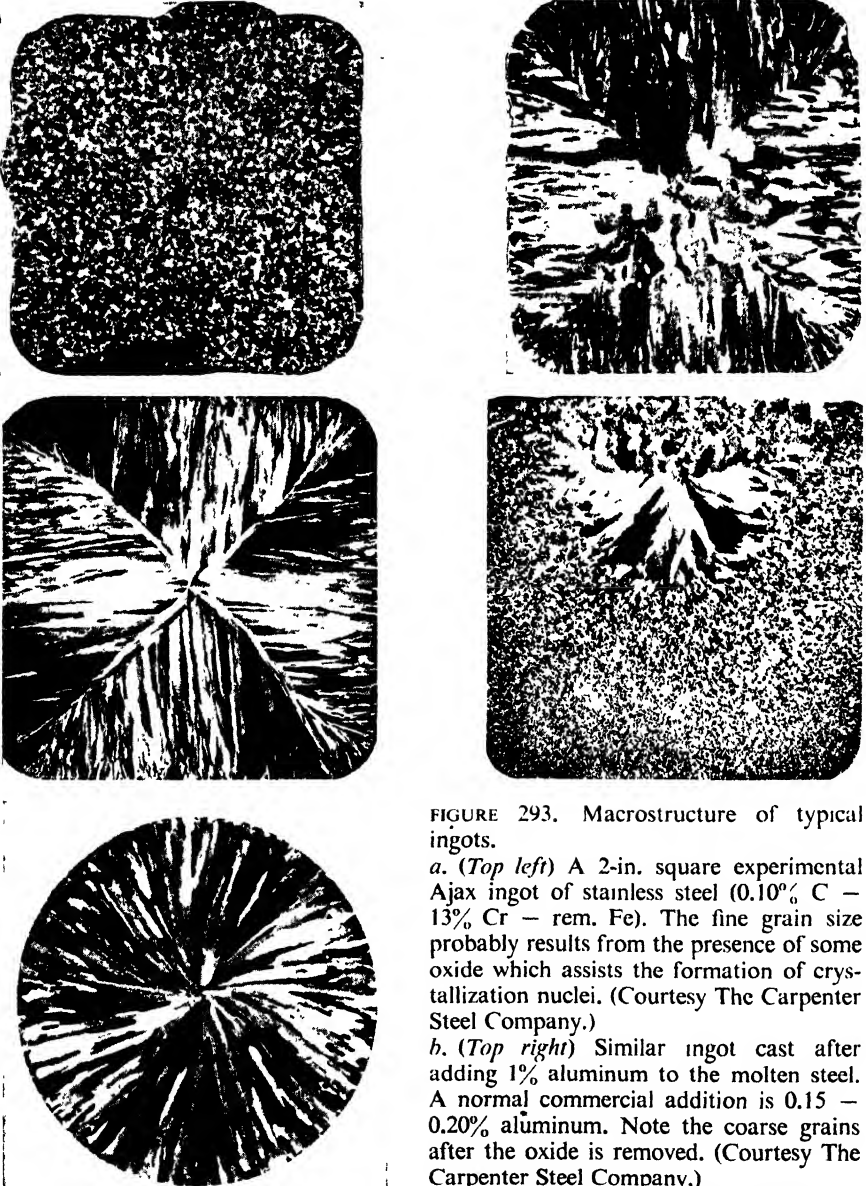


FIGURE 293. Macrostructure of typical ingots.

*a.* (Top left) A 2-in. square experimental Ajax ingot of stainless steel (0.10% C — 13% Cr — rem. Fe). The fine grain size probably results from the presence of some oxide which assists the formation of crystallization nuclei. (Courtesy The Carpenter Steel Company.)

*b.* (Top right) Similar ingot cast after adding 1% aluminum to the molten steel. A normal commercial addition is 0.15 — 0.20% aluminum. Note the coarse grains after the oxide is removed. (Courtesy The Carpenter Steel Company.)

*c.* (Middle left) End-poured copper wire bar. (Courtesy Anaconda Wire & Cable Company.)

*d.* (Middle right) Horizontal-cast copper wire bar. Rapid cooling from the mold on three sides results in a fine grain size, but in the region last to solidify the grain size is much coarser. (Courtesy Anaconda Wire & Cable Company.)

*e.* (Bottom left) "Sunburst" structure in cast copper billet (end-poured). (Courtesy Research Department, Chase Brass & Copper Company.)



FIGURE 294. *a.* (Upper) Casting improperly designed with angular connections between thick and thin members, producing cracks as shown by arrows. *b.* (Lower) Same casting properly designed with resulting freedom from cracking. (From *Cast Metals Handbook*, 1940 ed., courtesy American Foundrymen's Association.)

as in Fig. 295, rather than abruptly. Progressive solidification from distant regions toward the risers and gate is desirable practice but it can seldom be realized because of complicating factors. Sections should be, in general, not less than 80% nor more than 120% of the thickness of adjacent sections.

*Chill casting* also tends to result in internal stresses and distortion, and for that reason is not particularly desirable under most circumstances, although at times the use of chills may be necessary in order to accelerate the cooling of a heavy section or to produce definite properties in the alloy used.

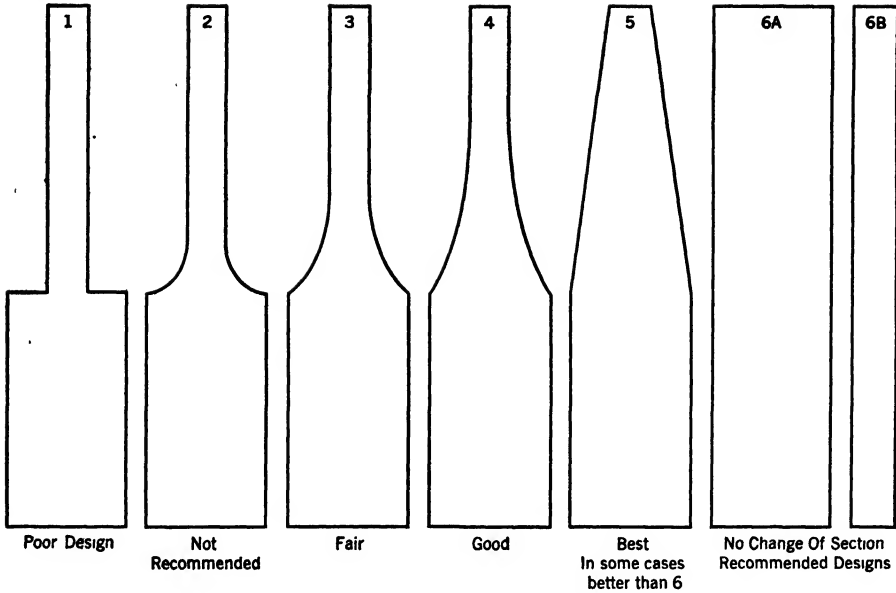


FIGURE 295. Alteration of design to reduce possibilities of hot tear formation to a minimum. (After C. W. Briggs, R. A. Gezelius, and R. Donaldson.) (From *Cast Metals Handbook*, 1940 ed., courtesy American Foundrymen's Association.)

#### IMPORTANCE OF DESIGN

The necessity for proper engineering design in castings cannot be too strongly emphasized. In addition to the metallurgical factors already mentioned, several other factors are significant:

1. As far as possible, the casting should be designed with the object of securing the maximum strength and stiffness with the minimum weight and distortion. The stiffness of the casting is dependent on both the modulus of elasticity of the metal from which it is made and upon its design. By proper use of section dimensions and of ribs and brackets for stiffening purposes (Fig. 296) many of the weaknesses inherent in both the metal and the casting can be compensated for in the design. In using such ribs and webs it is important to offset or stagger them in order to give more uniform metal sections, and to provide more even solidification at their intersections. At best, however, they are a source of foundry difficulties, and their use should not be encouraged.
2. Although dry sand cores are widely used, they are also expensive to make, and the use of green sand throughout with the elimination of cores by proper design is of great help in decreasing costs, wherever it

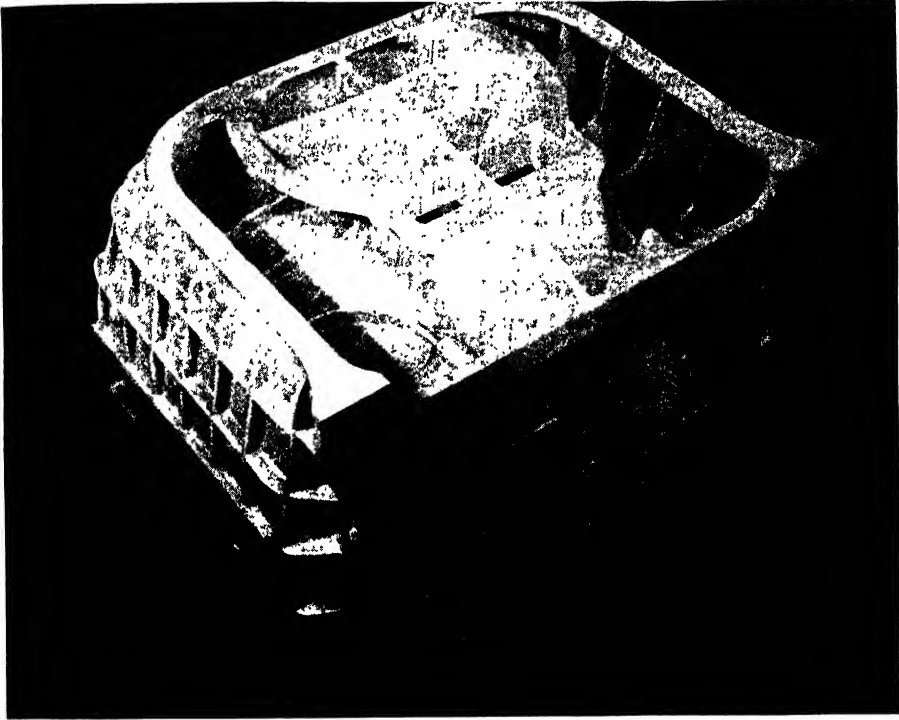


FIGURE 296. Aluminum casting in which ribs have been used for stiffening a large flat section. (Courtesy Aluminum Company of America.)

can be done. Deep pockets and small recesses that complicate molding are similarly to be avoided wherever possible.

3. A large part of the cost of castings comes in the operations required to finish them. By proper design all portions requiring machining may be made readily accessible, and these costs can be kept to a minimum. Also, the perfection of the casting with regard to soundness, under these circumstances, is of prime importance and justifies in many cases rigid inspection procedures. A casting that is given expensive machining operations before it is discovered to be unsound or unsatisfactory in other ways is definitely uneconomical for obvious reasons.

#### INVESTMENT CASTING

For making small or intricate castings weighing from a few ounces to a few pounds and of such accuracy that no subsequent machining is necessary, the so-called lost wax process has recently come again into fairly widespread use, usually under the name of precision casting or investment



casting. In this process a pattern of wood or some other readily worked material is made, true to size and shape and without taper. Over this a quick-setting material, such as plaster of Paris, is poured, using as many partings as are required to remove the various sections readily after they have hardened. After the pattern is removed the plaster mold is again pieced together and used to produce as many wax patterns as are needed. For some patterns, molds cast of soft metal or even machined from steel have been used when the number and nature of the parts to be made justified the cost.

Several of these wax patterns are then located, with a suitable sprue from each joining it to a central runner, and the entire assembly is encased in another material, usually a ceramic, to form a new mold. After this sets, the wax is melted out and molten metal is poured or forced into the hot mold.

Aside from the precision in dimensions attained, and usually a tolerance of  $\pm 0.010$  in. per in. is considered good, the advantages of the process lie in its ability to make any number of wax patterns and hence any number of castings without damage to the original pattern which is retained intact. Investment casting is particularly well suited to either small or mass production as long as the parts are difficult to machine and, hence, command a good price.

#### CENTRIFUGAL CASTING

Centrifugal force has been used for many years as a source of pressure to increase the denseness of castings, particularly cast-iron pipe. As illustrated in Fig. 297 the centrifugal casting<sup>3</sup> method is applicable to two types of products:

1. *Symmetrical objects*, like pipe and other tubular products, can be rotated about their axis of symmetry. The metal is thus forced against the wall of the rotating mold and is chilled at a rate largely determined by the mold material, the mold temperature, and the degree of superheat in the molten metal. The inside surface of the casting, being the last to solidify, will usually contain most of the segregated impurities, dross, etc., and is generally bored out to ensure a clean surface and solid metal. The outside surface may also be unsound, if any gas is entrapped by the chilling, and is usually scalped also. The fact that guns of fairly large caliber, for which forging was once considered to be the only feasible method of production, have been successfully cast centrifugally on a production basis is evidence enough of the quality of properly made castings. The specific conditions

<sup>3</sup> See also *Symposium on Centrifugal Casting*, Steel Founders' Society of America, Cleveland, Ohio, 1943; *Symposium on Centrifugal Casting*, A.S.T.M., Philadelphia, Penna., 1944.

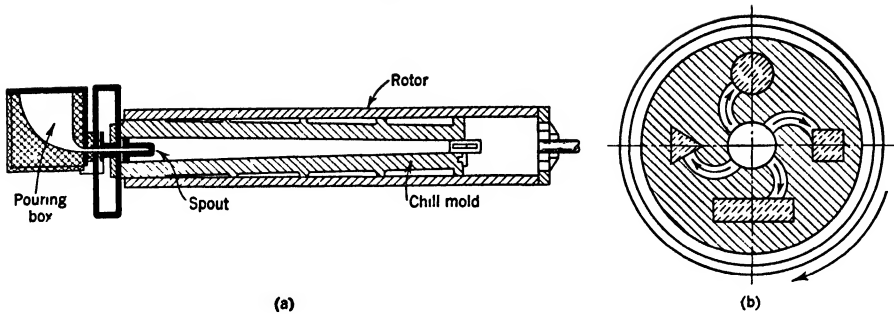


FIGURE 297. Two types of centrifugal casting methods: *a.* With mold rotating on a horizontal axis. *b.* Arrangement for pressure casting asymmetrical shapes which cannot be rotated about their own axes. (Courtesy *The Iron Age.*)

for each type of casting must be determined carefully if best results are to be secured. This requires a sizable production run. The major difficulties, other than those mentioned above, seem to arise from (*a*) surges in the flow of the molten metal, (*b*) a tapered hole caused by the slight inclination of the mold, and (*c*) a tendency of the hot casting to stick to the mold and tear itself as it shrinks longitudinally. All of these can be corrected, however, if proper precautions are taken.

2. *Small unsymmetrical objects* can be cast centrifugally by attaching them to gates radiating from a central feeder like spokes from the hub of a wheel. Although this may prove satisfactory and quite feasible, it can seldom be justified economically over the more usual sand or permanent mold methods. In making castings by this method all the precautions required with ordinary castings must also be taken, and many of the objectionable features of ordinary castings will still be present. In particular the object will still have a cast structure, the pressure being by no means great enough to produce a structure similar to that of a forging or other worked part.

The *Soro process*, which is usually classed as a method of continuous casting, is actually a centrifugal casting process for making rod at a high rate of production. A ring of any simple uniform cross section is first cast centrifugally. When removed from the mold this can be split and opened to give a rod about 6–8 ft long and suitable for direct use or for redrawing. The method is adaptable to both ferrous and nonferrous metals in sizes of  $\frac{1}{2}$ –4 in. in diameter, but has not as yet found extensive use in this country.

#### CONTINUOUS CASTING

The possibility of *direct casting* of metal to a product close to the finished condition has intrigued engineers for over 75 years. Many methods

have been developed and patented<sup>4</sup> but only a few of them really can be said to be practical. Aluminum and other low-melting alloys can be made with little difficulty; copper and similar alloys present many more problems because of the temperatures involved; and the ferrous materials are even more troublesome for the same reason.

Fundamentally, all the methods in use today can be classed under one of the following types: (a) *stationary mold*, (b) *moving mold*, (c) *draw casting*, (d) *strip casting*.

**STATIONARY MOLD CASTING.** This modification is typified by the *Alcoa D.C.*, the *Williams*, and the *Goss* processes.

The Alcoa D.C. process, now being used on a production basis for casting 24 in. by 12 in. slabs and 6–8 in. rounds of aluminum and its alloys, consists essentially of a permanent water-cooled aluminum mold the bottom of which is on a hydraulic elevator. As the metal is poured the elevator slowly drops the ingot through cooling sprays until the desired length is cast. Pouring is then stopped until the ingot is removed. The surfaces produced are only fair and scalping must usually be used.

The Williams process, which has been developed for use with ferrous materials, secures rapid cooling by using a thin-walled mold made of a good heat conductor, such as copper or brass, and high-velocity water cooling. The outside skin of the casting is thus solidified by rapid chilling even though the inside is still molten. This produces a high ferrostatic pressure so, to prevent the walls from bulging, the billet must be passed through a series of sizing rolls as it emerges from the bottom of the mold. During this stage water sprays assist the cooling. Alloy steel billets 4 in. square have been cast by this method at speeds up to 10 ft per min. Blistering of the surface is the major difficulty.

The Goss process is a relatively new development, the only unit in operation being designed to cast 4-in. square steel billets. Units to cast 1 in. by 9 in. slabs and  $\frac{1}{2}$  in. rounds are under consideration. This process makes use of two relatively new ideas. The metal first passes into a *preforming chamber* which is preheated to about the melting point of the metal being cast. By preforming to the desired shape before chilling begins, gassing is supposedly minimized. Next the metal passes into a *forming chamber* which consists of a water-cooled mold having a “nonwetting” surface. For steel, a chilled copper surface impregnated with graphite is used. Oxides of aluminum and chromium may also serve as lubricants. By this means the surface is chilled as drastically as possible in the mold and then final cooling

<sup>4</sup> This general subject is discussed thoroughly by T. W. Lippert, *Iron Age*, 145, 1940, 31–39, 44–47. See also *Symposium on Continuous Casting*, A.I.M.E., New York, N. Y., 1944.

is achieved by spraying water directly on the surface. The metal leaves the mold at about 1900 F (1040 C). Lubrication ports are spaced about 1 ft. apart to permit graphite under pressure to be forced into any section of the mold.

**MOVING MOLD CASTING.** The "ideal" method, of casting metal between split molds on chains, was patented early in this century and has been revived many times since but has never been successful because of the gradual deterioration and distortion of the mold surfaces which makes a leakproof joint almost impossible. At present the *Yonghans-Rossi* and the *INCO* processes are about the only ones using a moving mold.

The *Yonghans-Rossi* process has been most successful on copper-base and aluminum-base alloys. Copper-alloy extrusion billets 8 in. in diameter and 8 ft long have been cast at a rate of about 15,000 lb per hr for long periods. Billets up to 16½ in. diameter have been cast in Europe as well as slabs 24 in. by 4 in. Metal melted in an induction furnace flows by gravity into a ladle and then, by bottom pouring, into one of two holding furnaces where it is maintained under a nitrogen or other oxygen-free atmosphere. Because of these precautions even such refractory alloys as aluminum bronze and aluminum brass can be cast without difficulty. Pouring is started by use of a dummy billet. The mold moves down slowly at the same speed as that of the emerging billet for about 1¾ in., and then snaps back quickly as the metal solidifies and shrinks away from it. The metal is introduced into the mold below the surface of the molten metal thus further protecting it against oxidation. To assist the cooling, water is forced up between the metal and the mold and over the top of the molten metal, the steam layer so formed protecting the surface also. This rapid cooling facilitates shrinking the cast billet away from the mold surface. Withdrawal into a region where water sprays can cool it directly is assisted by means of pinch rolls with a variable speed control. The solidified billet can be cut to any convenient length.

The *INCO* process pours metal into an ingot mold consisting of individual half forms which open and close automatically, the billet moving down slowly into a region of cooling sprays as it solidifies. The method is in commercial use but not many details have been released.

**DRAW CASTING.** Both the *Eldred* and the *Poland* processes use this method for producing rod and billets. The basic idea of both methods is illustrated in Fig. 298. Water-cooled graphite or carborundum dies are used and rods 5/8–6 in. in diameter are withdrawn slowly at a rate dependent on their speed of solidification. Either horizontal or vertical (bottom) casting may be used and water sprays are frequently used to accelerate cooling.

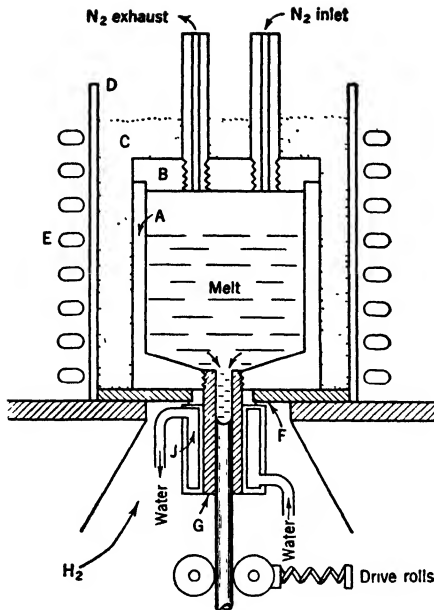


FIGURE 298. Schematic view of laboratory setup which preceded and illustrates the principle of one of the commercial continuous draw-casting processes. (From J. S. Smart, Jr., A. A. Smith, Jr., and A. J. Phillips, *Trans. A.I.M.E.*, 143, 1941, 272-286.)

only fair and must usually be scalped before piercing.

**STRIP CASTING.** As originally developed, the *Hazelett process*<sup>5</sup> was intended to cast molten metal between water-cooled rolls, which would chill it, and then guide it through reducing rolls which would hot-work it. The process was thus a means of direct rolling, as indicated in Fig. 299a. This method was slow and it was found that, at temperatures above the melting point of copper, the rolls would not last. Fire cracking and surface checking of the rolls were common because of the severe temperature changes encountered. In addition, the cast metal tended to segregate and fold badly and at times stuck to the rolls. In the original form thicknesses as low as  $\frac{1}{4}$  in. and widths as great as 50 in. seemed to be feasible.

Careful study of these production difficulties resulted in the drastic redesign shown in Fig. 299b. The actual cooling surface against which the metal is cast is a thin ring which can be made of ordinary low-carbon strip steel if desired. This passes over a driving roll and under a topping roll which is only about  $2\frac{1}{2}$  in. in diameter and  $\frac{1}{8}$  in. thick and is cooled by high-

<sup>5</sup> See C. W. Hazelett, *Mech. Eng.*, 61, 1939, 923-924.

The Eldred process has never been too successful, largely because of the slow speed, even though attempts have been made to overcome this by increasing the number of orifices.

The Poland process, developed by the American Smelting and Refining Company, and hence sometimes called the *A.S.&R. process*, has been used for several years for the commercial production of copper-piercing billets 3 in. in diameter and cut to 50-in. lengths, and has now been developed to cast both rod and tube of many copper-base alloys, particularly those containing tin or lead. The metal in the interior of the billets is very clean and dense because of the protection given during casting, the absence of dross and gases, and the constant hydrostatic head maintained during solidification, and has a remarkably high specific gravity, but the surface is

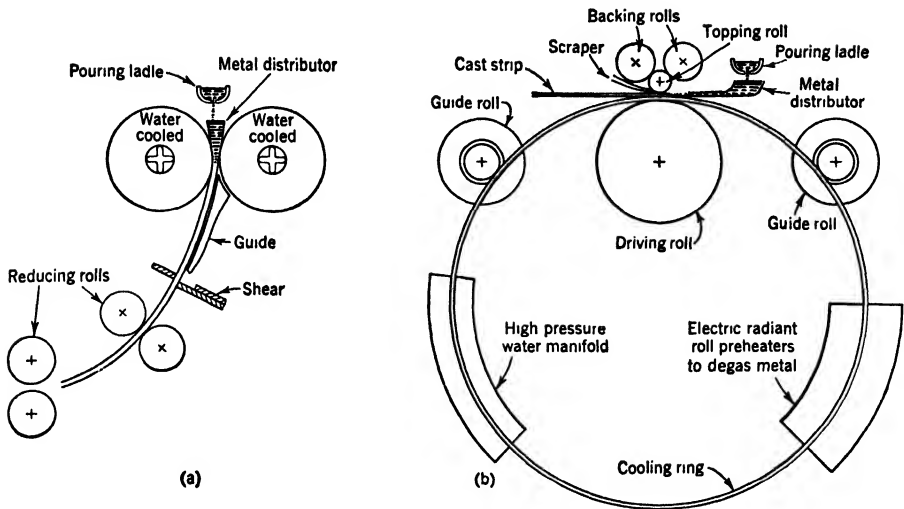


FIGURE 299. Principle of the Hazelett process for the direct rolling of sheet.  
*a.* Schematic arrangement of the original method which has been largely abandoned because of segregation, nonuniformity of cooling, slow speeds, and inability to produce thin sheet.  
*b.* Schematic representation of one of the improved strip-casting methods developed to overcome these difficulties.

pressure water passing through it. Operating speeds are so great that the metal is in contact with the cooling ring for only about 2 in. and cools in about 1/50 sec. Consequently little trouble is encountered with the ring from overheating. In fact it is found advisable to preheat the ring somewhat to degas it. By this means stainless steel strip 8 in. wide and 0.025 in. thick has been cast at speeds approaching 500 ft per min and copper alloys can be cast equally well. It has been said that the major difficulty now is to secure enough molten metal to keep the machine running and then to find a use for the strip produced. The tendency toward segregation was eliminated by reducing the pressures to values about 10% of those used previously. This meant, however, that the temperature variations at the end of the rolls had to be eliminated to prevent the rolls from being pushed apart.

Because this process reduces the thickness of the metal after it casts it a recrystallized structure more typical of a hot-worked metal than a casting is secured. The grain size is seldom uniform, however, because of the temperature variations and of differences in applied compression throughout the cross section.

#### DIE AND PRESSURE CASTING

In most machines for die or pressure casting, the principles of which are shown in Fig. 300, molten metal is forced from a reservoir, either by air

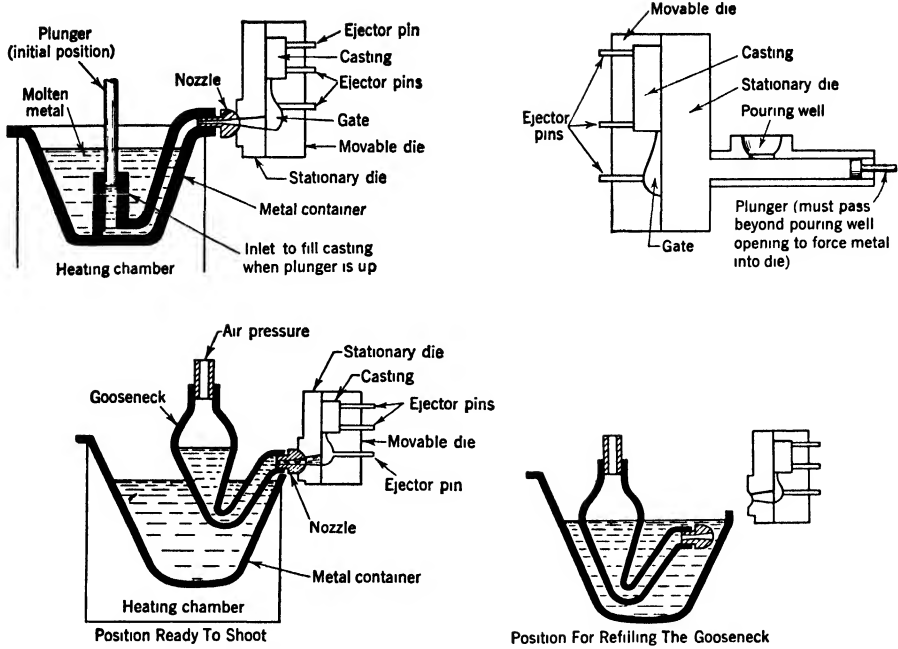


FIGURE 300. Diagrammatic representation of different types of die-casting machines.  
*a.* (Upper left) Typical piston machine. Plunger, heating chamber, metal container, and die carriage are part of the same machine.  
*b.* (Upper right) Typical cold chamber pressure-casting machine. Plunger, cylinder, and die carriage are part of the same machine. Melting pot and metal container are separate.  
*c.* (Lower) Typical gooseneck machine. Gooseneck, metal container, heating chamber, and die carriage are part of the same machine.  
 (From *High-Production Methods for Metal Parts*, courtesy General Electric Company.)

pressure or by a plunger, into a metal mold, the two halves of which are held together by hydraulic, air, or mechanical pressure. In true die casting (usually of lower melting alloys), the metal is cast while molten, but in the higher melting alloys, in which the alloys are really pressure cast, the metal is partially solidified, and is actually pasty when forced into the die. Much higher pressures are required as a consequence of this.

Die and pressure castings, primarily made of zinc-, aluminum-, tin-, or copper-base alloys, have many advantages,<sup>6</sup> among which are:

1. A low cost, a large part of which can be attributed to the fact that, except for the important zinc alloys and certain other alloys for castings requiring high mechanical properties, they can be made directly from a liquid which can be satisfactorily produced by melting relatively inexpensive scrap metal. In addition, they are made rapidly and require

<sup>6</sup> See also *Die Casting for Engineers*, The New Jersey Zinc Company, New York, N. Y., 1942.

a minimum of finishing. Their advantageous cost position can be further increased by proper design. Threads, both external and internal, can be cast directly and require only chasing to finish. Likewise, internal cavities can be cast by the use of cores. However, both internal screw threads and coring tend to decrease production somewhat because more time will be required either for setting up the die or disengaging the casting. Since the dies required are usually fairly expensive to make, a large run of castings must be made if the cost per unit is to be kept reasonable.

2. A good structure, because of their rapid solidification in a metal mold. Gas evolution is either prevented or else limited to microporosity. This tends to give the die casting a compact fine-grained structure, as well as properties which are superior to those of castings of comparable composition made by other methods, although they are somewhat poorer than those of wrought or forged alloys. Fairly close dimensional tolerances can also be maintained, because of the rapid solidification, but, as a rule, the composition of the alloy is important, and certain fairly definite purities must be maintained if these close tolerances are to remain stable with time.
3. Good machinability, with no interference, as in many castings, from sand inclusions. The alloy used will also influence this, however.
4. Almost any section thickness, thin or thick.
5. Excellent reproduction of details in clean castings which have a good appearance.

Fig. 301 shows several typical parts made of zinc-base die castings and illustrates some of the characteristics which make these alloys so useful.

### *Extrusion*

In the various methods of extrusion, only pressure is applied to the metal. The metal must be, however, at a temperature at which it is sufficiently plastic, even though completely solid, to flow through a suitably shaped orifice under the action of that pressure. The most important methods used for extruding metals are: (a) *hot extrusion*; (b) *cold extrusion* by the Hooker Process; (c) *impact extrusion*.

Because of the plasticity requirements, the alloys and the temperatures used are mutually interdependent.

#### HOT EXTRUSION

Two methods have been perfected for the hot extrusion of metals, the *direct* and the *inverted* methods. The former is more widely used.



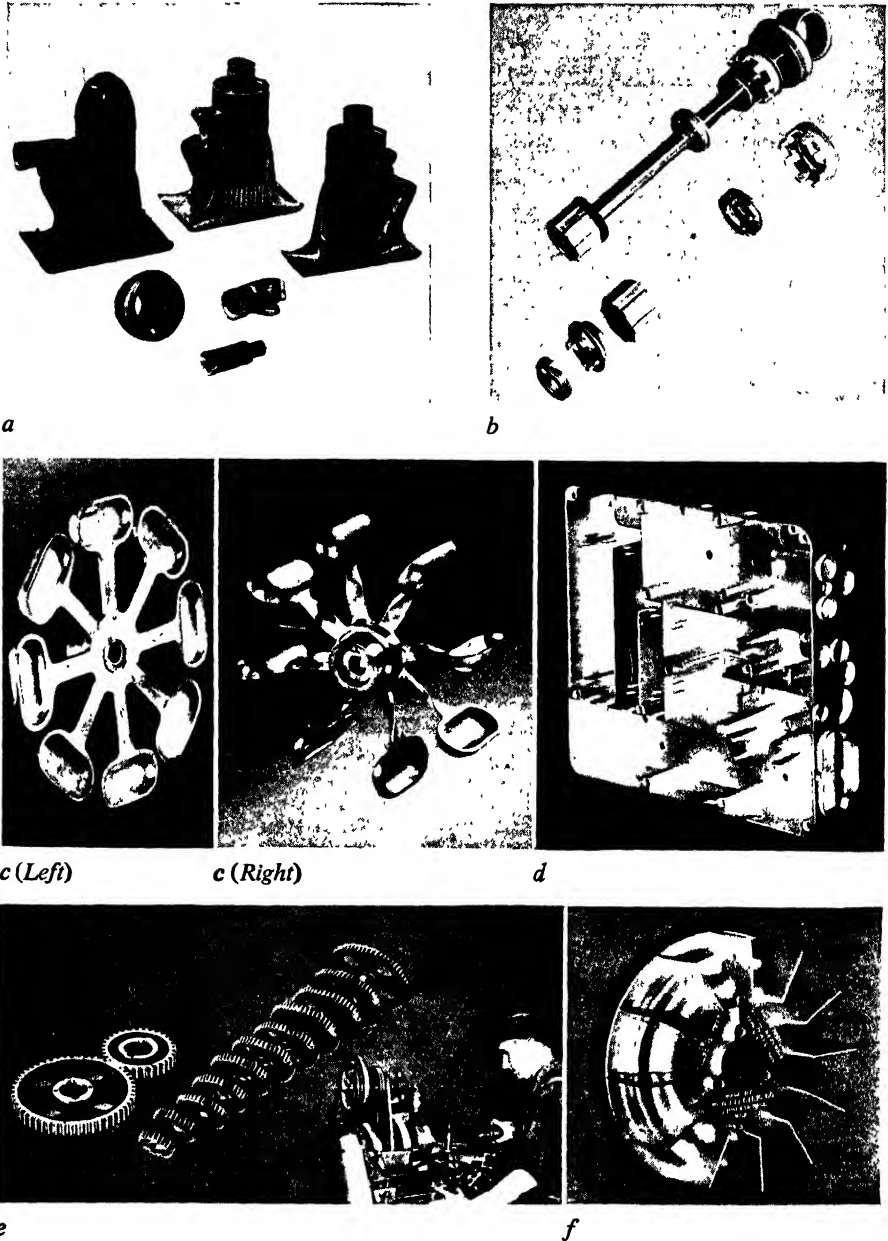


FIGURE 301. Several typical parts made of zinc-base die castings illustrating some of the characteristics for which these die castings are used.

*a.* Strength. Hydraulic automobile jack with a one-piece housing which will withstand a pressure of 60 tons on a  $\frac{1}{8}$  in. cross section. Note the complex coring required to make this casting.

*b.* Impact resistance. Valve parts on the plunger of a double-action pump.

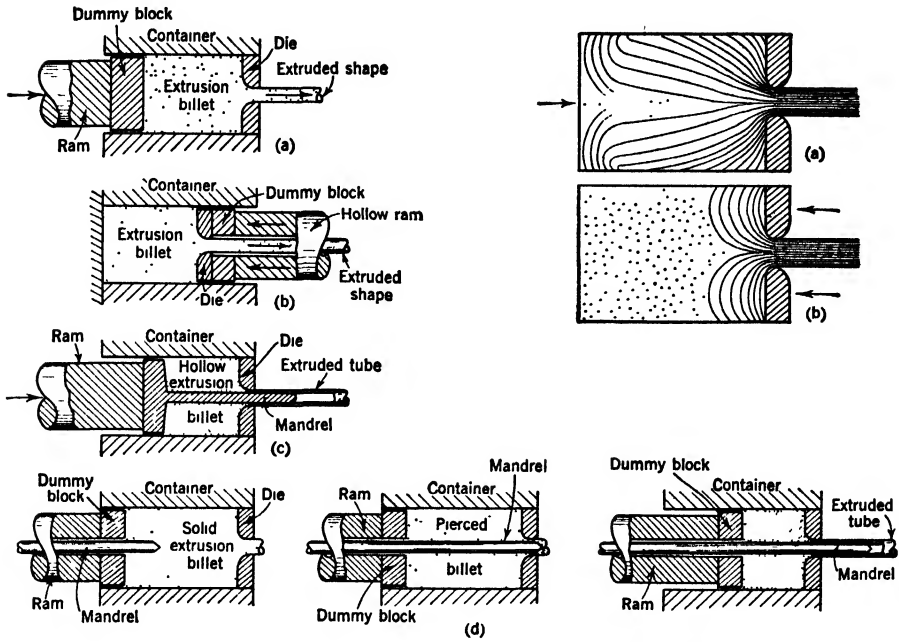


FIGURE 302. Diagrammatic representation of different types of extrusion processes.  
 a. Direct extrusion, with a *sleeve*, of a rod or shape.  
 b. Indirect or inverted extrusion.  
 c. Extrusion of a tube from a hollow billet.  
 d. Extrusion of a tube from a solid billet.

FIGURE 303 (*Upper right*) a. Metal flow in direct extrusion, schematic. b. Metal flow in indirect extrusion, schematic.

In the direct process, a billet of the metal is placed in a strong cylindrical chamber and then compressed, as indicated in Fig. 302a, either in a horizontal or a vertical press. A hard steel die, in which one or more suitably shaped orifices have been prepared, is the sole means of egress of the metal. A *dummy block* is placed between the ram and the billet to avoid excessive wear on the former. The use of this block also aids in minimizing friction by permitting a ram smaller in diameter than the cylinder to be used. If a dummy block smaller than the cylinder is used, a *sleeve* of scrap will remain in the chamber, but this practice need not necessarily be followed. Both mechanical and hydraulic presses are used, although the latter pre-

- c. Ductility. Impeller wheel in which each cup arm is cast flat (left) for simplicity and then twisted through a 90 deg angle to shape (right).
  - d. Castability. Complex one-piece, automobile radio chassis, which could not be produced economically by any other method, is die cast in one shot.
  - e. Wear resistance. Gears for a small bench lathe.
  - f. Bursting resistance. Armature cooling fan for an electric motor.
- (Photographs courtesy The New Jersey Zinc Company.)

dominate because, with accumulators, they permit the use of higher pressures. The extrusion billet may be either cast separately, and then preheated to the desired temperature; or, with low melting alloys such as those of lead and tin base, it may be cast molten into the extrusion chamber, and allowed to solidify there. Some of the shapes commonly extruded in copper alloys are shown in Fig. 304.

In the inverted process (Fig. 302*b*), the container is closed at one end and the die is placed between the billet and a hollow ram so that, as the ram is advanced, the die is pressed into the billet. The shape is thus extruded through the die, and passes back through the hollow ram. In this process a sleeve of scrap usually results although it may vary in amount depending upon the exact method of operation used.

#### METAL MOVEMENT DURING EXTRUSION

In direct extrusion, the billet has to move forward in relation to the walls of the container and as a result metal adjacent to the die tends to be extruded first. Because of friction between the billet and the container wall, the inside of the billet is sheared through, and the outside skin and back end of the billet are the last to pass through the die. This flow is illustrated in Fig. 303. The surface of the billet tends to be turned in by the dummy block, and flows toward the center of the rod, thus giving what is known as a *pipe* or *extrusion defect*. Since the surface of the billet usually contains most of the oxides and other inclusions, most of this defective material can be removed by discarding a certain amount of the back end of the extruded shape. This may run as high as 30% of the total length in some cases, however. In some alloys, this oxidized material may form on the surface of the rod, which will then require *scalping* or surface machining before it can subsequently be worked.

In the inverted process, there is no relative movement between the billet and the container. As the die moves forward, the metal flows through the die aperture, and the balance of the billet is essentially undisturbed. Unfortunately, however, this method tends to leave the outer skin in the container as a thin shell which must be removed at the end of the extrusion. Under some conditions, this may slow down production considerably.

#### EXTRUSION CONDITIONS

The pressures required to extrude will vary from about 40,000 to as high as 90,000 psi for lead-base alloys, and may exceed 150,000 psi for copper-

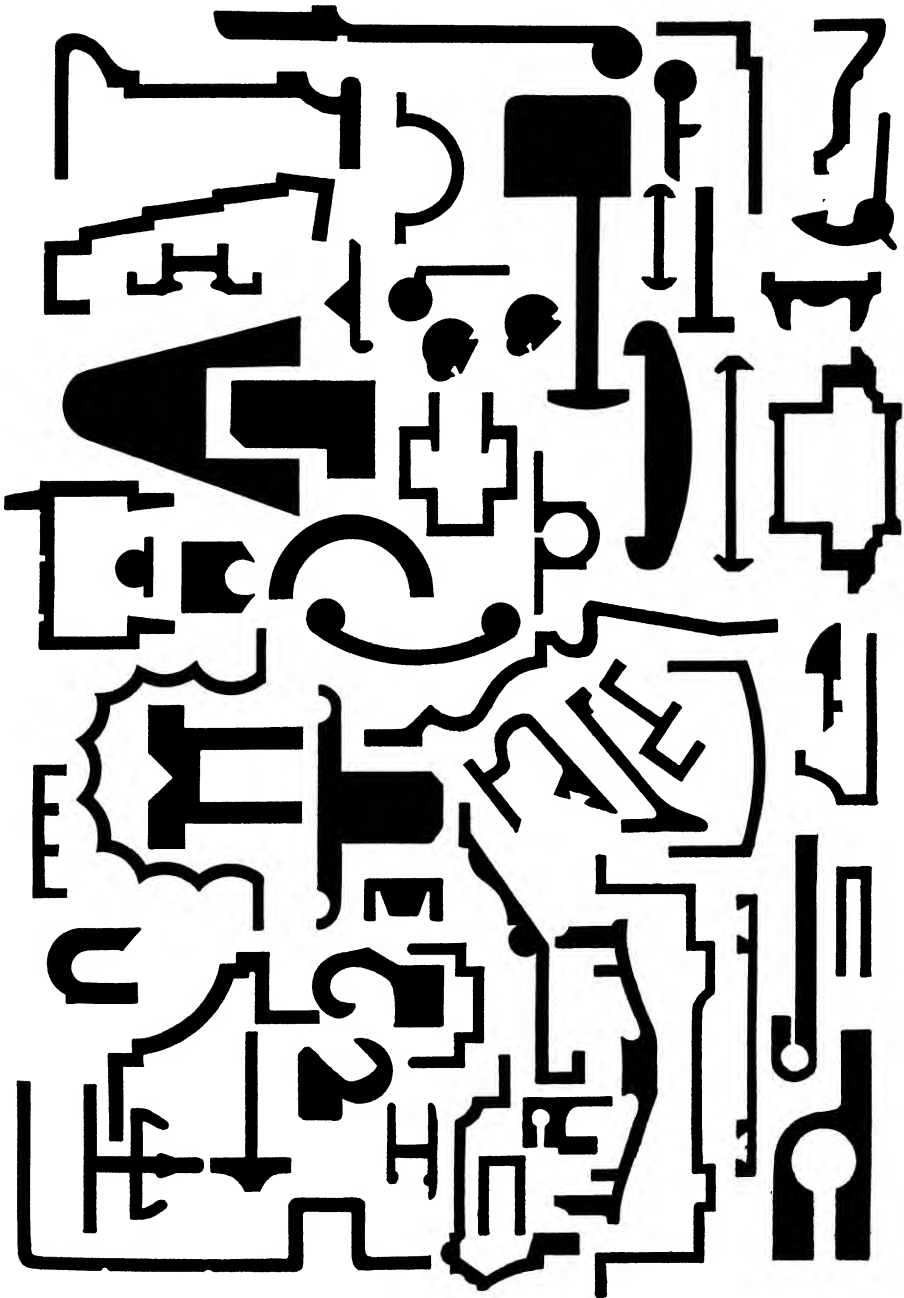


FIGURE 304. Some of the many different sections that can be extruded in copper alloys. (After Copper Development Association publication.)

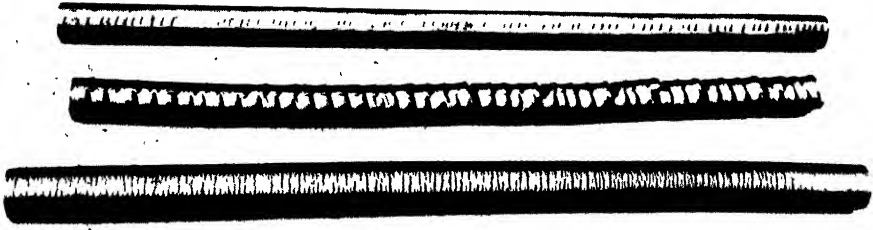


FIGURE 305. Cracking in magnesium rod and tubing that was extruded too rapidly or too hot. (Courtesy The Dow Chemical Company.)

aluminum-, or zinc-base alloys. Presses, consequently, must be built to supply these pressures, and may vary in capacity from 200–5500 tons, depending on the alloy and the shape being extruded. Likewise, extrusion speeds vary, depending upon the metal and upon the size and complexity of the section being extruded, from below 5–10 ft per min to higher than 1000 ft per min although the range for any one alloy is not usually this wide.<sup>7</sup> Unless desirable structures or physical properties can be produced only at slow speeds it is usually desirable to extrude as rapidly as possible because of the increased production. However, since the highest speeds are apt to produce *checking* or breakage of the surface or edges, as illustrated in Fig. 305, these must also be avoided.

#### METALLOGRAPHIC STRUCTURES OF HOT EXTRUDED SHAPES

Hot extrusion is essentially a hot-working operation. Hence, the metallographic structure of the resulting shapes may vary considerably. As in all other hot-working operations, the temperature, pressure, impurity content, and rate of cooling are the most important factors, and such variations as hot coiling or flattening after extrusion will also exert their effect. It will usually be found, therefore, that different structures will exist in the front and back ends and in the center of lengths of extruded shapes. Typical structures for extruded naval brass are shown in Fig. 306.

#### SPECIAL MODIFICATIONS OF EXTRUSION

Certain products are made commercially by modifying somewhat the usual extrusion methods.

**LEAD CABLE SHEATHING.** In making lead cable covering, the cable core is passed through the die block assembly (Fig. 307) while the sheathing is extruded around it by vertical compression from a lead cylinder.

<sup>7</sup> See, for example, D. K. Crampton, *Trans. A.S.M.*, **25**, 1937, 55–83.

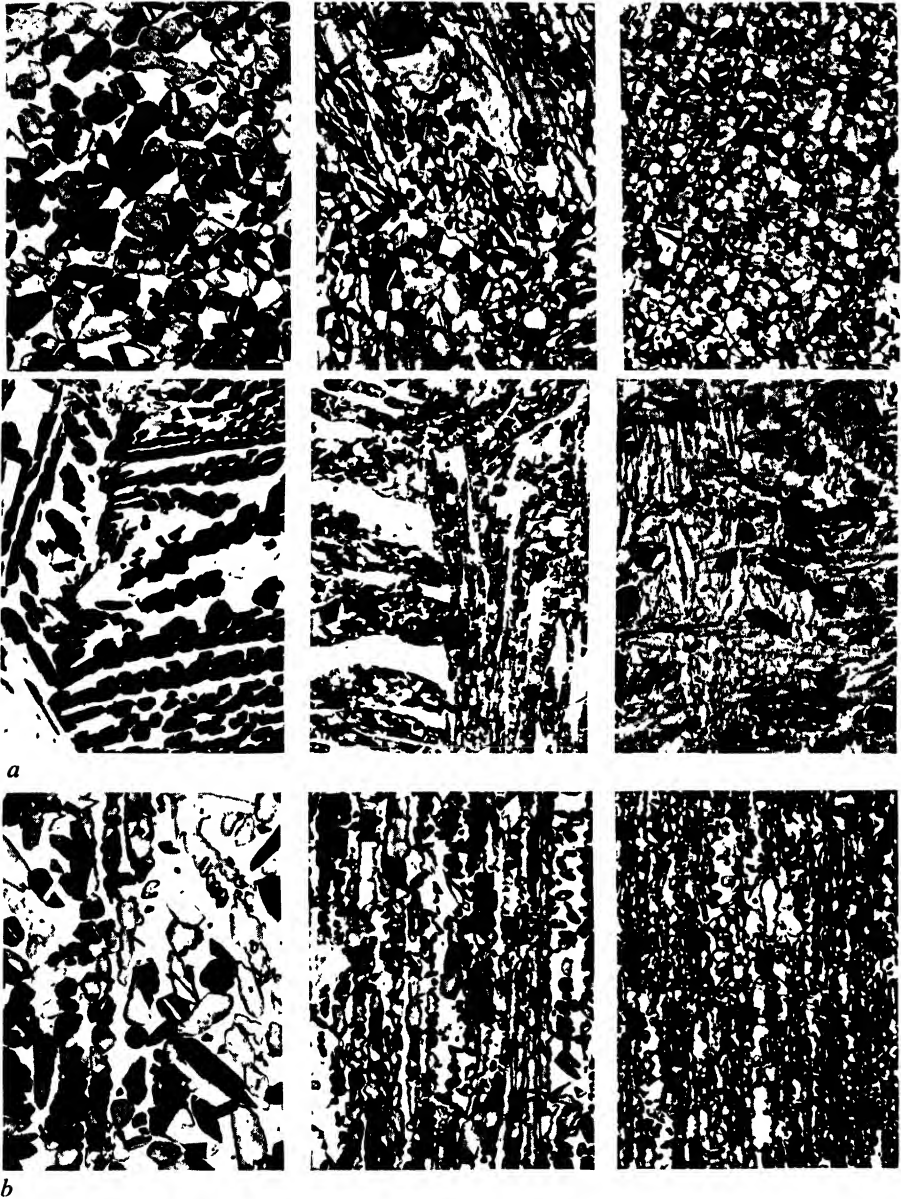


FIGURE 306. Variations in metallographic structure of an extruded alpha-beta brass of the Muntz or naval brass type.

*a.* Six different structures arising from differences in operating conditions.

*b.* Three different structures resulting from position in  $1\frac{3}{8}$  in. diameter bar extruded at a low temperature. *Left*, specimen taken 6 in. from front end. *Center*, specimen taken from middle of bar, from 1 ft from front end to two thirds of length. *Right*, specimen taken from extreme back end. Extrusion direction vertical.

Etched with  $\text{NH}_4\text{OH} + \text{H}_2\text{O}_2$ . Originally  $\times 75$ ; reduced somewhat in reproduction. (Photomicrographs courtesy Research Department, Chase Brass & Copper Co.)

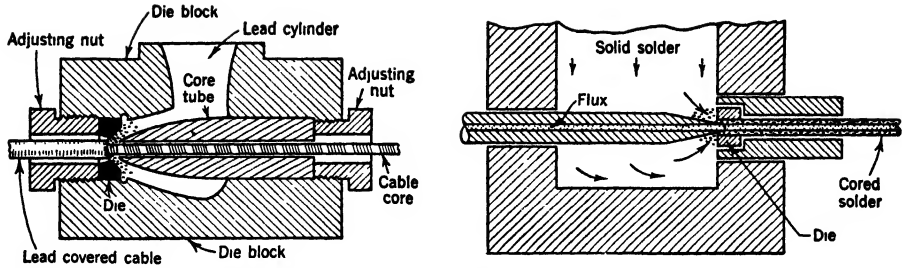


FIGURE 307. (Left) Section through die-block assembly used in making lead cable sheathing. (From D. K. Crampton in *Trans. A.S.M.*, courtesy American Society for Metals.)

FIGURE 308. (Right) Diagram of a solder extrusion machine for making cored solder wire. Molten solder fills the cylinder, is chilled, and then forced by hydraulic pressure through the die. As the hollow wire forms, flux is drawn into the core. Both vertical and horizontal presses are used for making cored wire. (Courtesy John T. Lewis & Bros. Co.)

**LEAD PIPE.** Lead pipe is also extruded vertically, by a modification of the inverted process, the die being held in the hollow ram and the extruded pipe coming out the top of the press, either in straight lengths, if of large, or in coils, if of small diameter.

**SOLDER WIRE.** Solder and other low-melting wire is extruded in a similar manner with sometimes as many as twelve strands coming out of the same die. Solder wire is also made, however, by casting the molten metal into a groove and then finishing with a pass through a wire-drawing die to clean up the surface. Rosin-core solders are made by a process similar to that used for lead cable sheathing, the solder being extruded around the core (Fig. 308).

**TUBING.** Tubing is extruded in both horizontal and vertical presses using a billet through the center of which a hole has been drilled or punched. Integral with the extrusion ram is a short mandrel which is long enough to pass through the billet and fit into the die before pressure is applied (Fig. 302c). During extrusion this forms the inside diameter of the tube, while the die forms the outside diameter. The conditions under which tubing can best be extruded vary with the alloy, and unless the optimum conditions are rather closely adhered to, excessive scrap will probably result. Some alloys are also extruded from a solid billet as illustrated in Fig. 302d. An auxiliary plunger first pierces the central hole and expands the billet to fill the extrusion chamber. When the auxiliary plunger reaches its proper position within the die it is locked in place and the main ram then completes the tube extrusion.

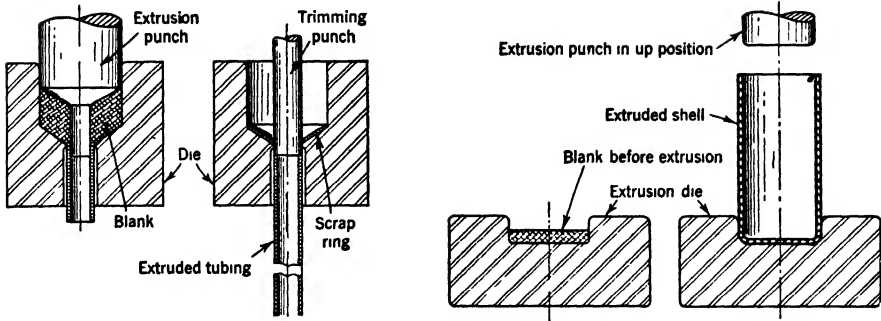


FIGURE 309. (Left) Diagrammatic sketch of the Hooker process as used for extruding aluminum tubing. (From *Impact Extrusion and Pressings*, courtesy Aluminum Company of America.)

FIGURE 310. (Right) Diagrammatic sketch of the impact extrusion process. (From *Impact Extrusion and Pressings*, courtesy Aluminum Company of America.)

#### THE HOOKER PROCESS

In the Hooker process, relatively heavy-walled cup-shaped blanks are extruded at high speed from a cup-shaped slug of metal, using ordinary crank presses instead of the usual extrusion press. The metal is generally fed into the press at room temperature, and there is little rise in temperature during the process. The process, in contrast to hot extrusion, is carried out at velocities as high as 2000 ft per min on relatively small amounts of metal. It is used chiefly for copper-base and aluminum-base alloys.

The die is open and the pressure is exerted by a shoulder on the punch (Fig. 309) the lower portion of which merely serves as a plug to determine the inside diameter. Commercially, two general types of products are made by the Hooker process: (a) small-arms cartridge cases; and (b) thin-walled seamless tubes in lengths usually less than 14 in.

In the Hooker process the metal is extruded *ahead of the punch* through an annular orifice between the die and the punch. Whether this process is more economical than the more conventional process of forming and shaping, which is described later, depends on the number of pieces being made, the dimensions, and the alloys required.

#### IMPACT EXTRUSION

Impact extrusion, also done cold, resembles the Hooker process except that the metal moves in exactly the reverse direction, a solid bottom die being used with the metal flowing *back over the punch*, which has no shoulder on it. Here a flat slug of metal is used (Fig. 310).



By this process shells or cups are made, up to approximately 10 in. in length, from  $\frac{1}{2}$ –4 in. in diameter and 0.003–0.045 in. in wall thickness, although the thickness is usually determined more or less by the diameter.

The process is used with aluminum, tin, lead, and zinc alloys to make collapsible tubes for tooth paste, paint pigments, shaving creams, certain types of food products, etc.

### *Mechanical Working*

#### HOT-WORK

Hot-work is any deformation at a temperature above the work-hardening range of the metal, regardless of the actual temperature concerned. Thus, certain metals, such as some grades of lead and tin, can be hot-worked at room temperature, whereas zinc and its alloys must be heated to about 200 F (95 C), and steel to above the critical range at about 1330 F (725 C). However, hot-working operations in steel are usually started at temperatures between 2300 and 1950 F (1250–1050 C), depending on the carbon and alloy content.

It is much easier to deform metal by hot-working than by cold-working not only because of its lower initial strength and hardness at those temperatures, but also because it neither strengthens nor hardens during the deformation process. Instead it remains relatively soft throughout. The pressure exerted by hot-work also tends to eliminate porosity by closing blowholes, and welding them shut more or less completely provided their surfaces are not oxidized, and tends to assist diffusion in removing a cored or inhomogeneous structure. Opposed to this, however, almost invariably the metal oxidizes or scales on the surface, is difficult to gauge, and, in addition, contracts during cooling to room temperature. It is, therefore, almost impossible to secure metal of a satisfactory appearance, except by subsequent chemical cleansing or pickling, or to control dimensions accurately. For these reasons it is a rapid and fairly inexpensive method of working metals but hardly a precision one. Its most important metallurgical effect probably lies in removing the columnar cast structure of the ingot, and replacing it with an equiaxed recrystallized structure. Other than this, it is principally a convenient method for reducing the thickness of or for shaping large amounts of metal rapidly and with a minimum expenditure of energy.

#### COLD-WORK

Cold-work usually is carried out at room temperature, although in principle it may be done at any temperature below the hot-working range, i.e.,

below the temperature of rapid strain recrystallization. The advantages accruing from room-temperature working are of greater importance than any decrease in resistance to deformation resulting from the use of an elevated temperature below the hot-working range would be.

Cold-working hardens, strengthens, and embrittles the metal. Hence the magnitude of the reductions possible without cracking depends upon the material being worked. The metal heats up to some extent because of internal friction, but it also cools rapidly, and hence is controlled readily to close thickness tolerances. Accurate widths and lengths usually are secured by *slitting* or *shearing* after working. Because the metal does not scale, it is possible to secure almost mirrorlike surfaces with many metals and alloys, especially those of copper, aluminum, and nickel base, and certain ferrous alloys, such as the stainless steels. Cold-work is primarily a finishing operation. However if the alloy is hot-short, or brittle when hot, it may be necessary to work it cold throughout, using periodic annealing heat-treatments to soften the metal.

#### ECONOMIC FACTORS AFFECTING WORKING

The general characteristics of a given alloy will determine whether hot- or cold-working operations are more economical. Some metals and alloys, even though comparatively easily worked cold, are apt to be brittle or hot-short when worked hot. Frequently, alloys, like the alpha brasses, can be worked either cold or hot, but the temperature range within which hot-working can be carried out successfully may be so limited in extent that it would not be economical to try to maintain it on a commercial basis. However, even under these conditions, proper control of impurities often may make hot-working economical, as has been found out for cartridge brass (70% Cu-30% Zn), for example, which can be successfully hot-worked if the lead is kept below 0.02%. Other alloys, such as the beta brasses, for example, may quite readily be worked hot, but are apt to be cold-short or brittle when worked cold. Consequently, the optimum conditions for working any alloy must be determined by trial.

Hot-working operations, in general, permit the handling of a greater tonnage of material than cold-working, and are better adapted to continuous operation as long as the metal can be maintained in the correct temperature range. Cold-working operations, on the other hand, are more apt to be carried out on a batch basis, and hence are likely to be appreciably more expensive. In addition, the intermediate annealing operations, and the handling incident to them, increases the labor costs of cold-working.

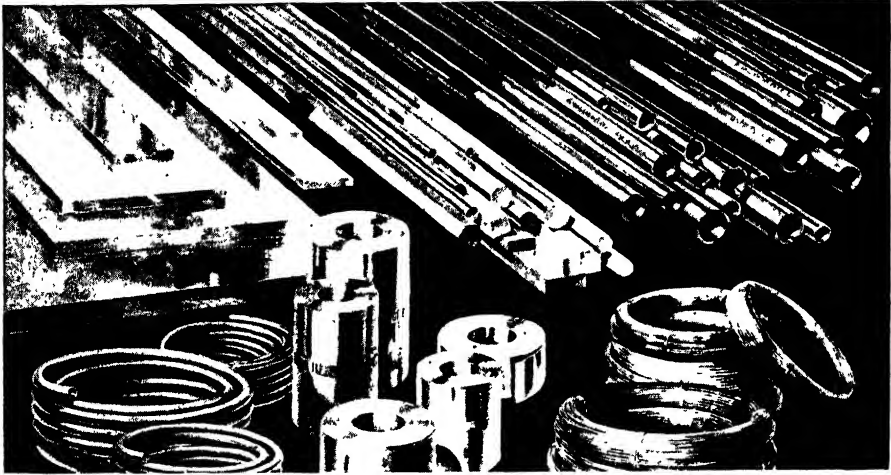


FIGURE 311. Some typical examples of the different forms in which metal can be produced by mechanical working. *Upper left*, plate; *upper center*, rod; *upper right*, pipe and tubing; *lower left*, coiled tubing; *lower center*, sheet and strip; *lower right*, wire. (Courtesy The American Brass Company.)

Figure 311 shows some typical forms in which metal is produced by mechanical working.

#### LIMITATIONS OF MECHANICAL WORK

Since hot-work does not harden the metal, theoretically it can be continued indefinitely. Practically, however, it is found that once the metal attains a certain minimum thickness, which depends on the composition and width, it tends to lose heat so rapidly that it is more economically cold-worked than hot-worked.

Cold-work, on the other hand, tends to harden and embrittle the metal to such an extent that only a certain limited reduction, dependent on the initial hardness and the rate of work-hardening, can be given without some sort of softening heat-treatment.

#### BLUE BRITTLE RANGE IN STEEL

Carbon steel is an unusual case, since its hot-working range is at such a high temperature that it might be thought more economical to cold-work just under this range instead of at room temperature. However, most steels have very low ductilities, either when worked in the temperature range of 300–700 F (150–370 C), or when cooled after having been heated in this range. The property changes with temperature in this range, as determined

by short-time tests, are typified by those shown in Fig. 312 for a forging steel. The range is called the *blue brittle range*,<sup>8</sup> because ordinary heat-treatment in it tends to produce a bluish-black surface oxide. This brittleness is believed to be caused, at least in part, by some form of aging or precipitation hardening resulting from the presence of carbon, oxygen, or nitrogen in the steel.<sup>9</sup> The relationship to aging is further strengthened by the fact that many "nonaging" steels prepared by special treatments show little or no tendency toward abnormal properties in these temperature ranges. However, the general effect is not unique with the steels. Many other alloys are brittle in certain ranges of temperature, and hence cannot be worked or used in these ranges.

### ROLLING

The probable direction of metal flow during rolling is indicated diagrammatically in Fig. 313. The surface layers are pulled downward and forward by the rolls in the region between points *A* and *B*, whereas between points *B* and *C* they are pulled forward very rapidly.

The *B* point separating these two effects is chosen arbitrarily here because so little actually is known concerning these reactions between the roll face and the rolled material.

In rolling, there is a combination of both compressive and tensile forces

<sup>8</sup> See also L. R. Van Wert, *Trans. A.I.M.E.*, **95**, 1931, 230-246; J. H. Hollomon, *A.S.M. Preprint*, 1946.

<sup>9</sup> See, for example, R. L. Kenyon and R. S. Burns, *Proc. A.S.T.M.*, **34**, II, 1934, 48-58.

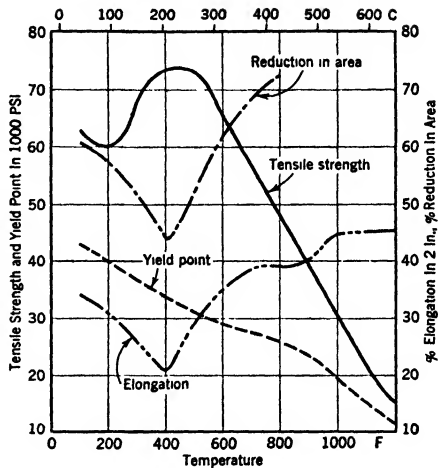


FIGURE 312. Change in tensile properties of forging steel with temperature. (From F. W. Martin in *Symposium on Effect of Temperature on the Properties of Metals*, A.S.T.M., 1932.)

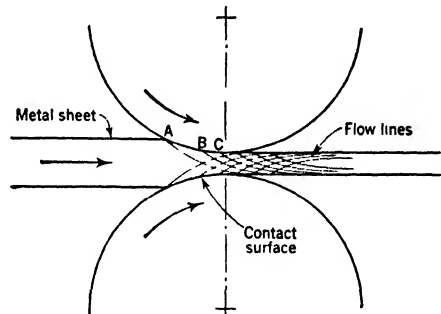


FIGURE 313. The process of rolling. Note that the force exerted has both a compressive component normal to the metal sheet and a tensile component parallel to the rolling direction at every point except the point of emergence, *C*.

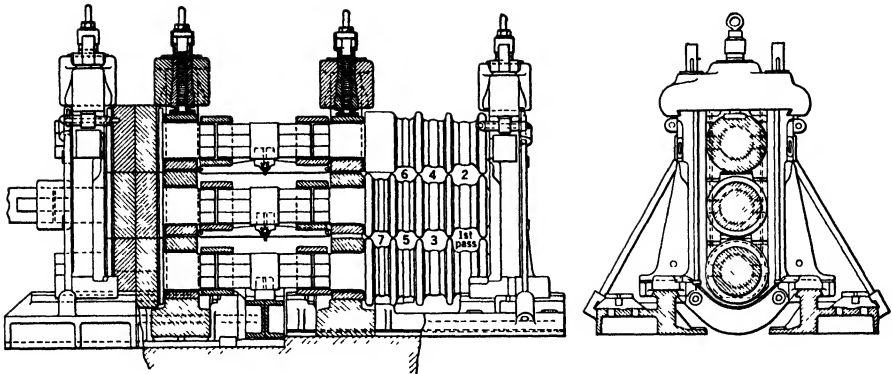


FIGURE 314. Sketch of three-high blooming mill, showing the relative positions and sizes of the seven passes. (From *The Making, Shaping, and Treating of Steel*, by permission of Carnegie-Illinois Steel Corporation.)

exerted on the metal. These forces tend to deform it symmetrically about a neutral plane, parallel to the surface, and to distort the grain structure.

#### HOT-ROLLING METHODS

Depending upon the plant and the metal being rolled, either unit or continuous mills, i.e., several units in series, may be used. Some of the various types of hot-rolling mills are described below.<sup>10</sup> The exact names used may depend, however, on the industry using them. In general, the term *break-down* is used to apply to the initial operations, and the terms *semifinishing* and *finishing* to apply to the intermediate and final operations, respectively.

The *blooming mill* or *bloomer* is a large and powerful breakdown mill (Fig. 314) sometimes called a *cogging mill*, the important parts of which are two or three appropriately grooved rolls the rotations of which are usually reversible. The distance between the rolls is adjustable, usually by electrically operated controls, and the rolls are often slightly corrugated, called *ragging*, to assist in gripping the ingot.

*Billet mills* are semifinishing mills usually smaller than blooming mills, and of two main types. The first type, the *three-high mill*, consists of three rolls placed in a row in a vertical plane. Each roll rotates in a direction opposite to the one adjacent to it. Thus the metal will move forward if fed between the bottom pair of rolls and backward if between the top pair. The second type, the *continuous* or *Morgan mill*, consists of a series of *two-high mills*, arranged in a row, each mill used for one pass. Bars, small I-beams,

<sup>10</sup> See, for a complete discussion of American practice, Quincy Bent, *Journ. Iron & Steel Inst.* (Lond.), 41, 1938, 62 pp.

angles, and a variety of other products are finished in this way. *Four-high mills* also are used sometimes, two of the rolls being backing rolls.

It was found early that by cutting appropriately shaped circumferential grooves in the rolls, and feeding the bar of metal into these grooves, shapes could be produced by rolling. Such a groove is called a *pass*. With the exception of plate, sheet, and strip mills, at the present time practically all rolls are grooved in some manner. Several sets of grooves may be used so the piece is shaped on successive passes through them as is indicated for a standard railroad-rail section in Fig. 315.

Several arrangements of these semifinishing and finishing mills are used, especially in the steel industry, in addition to the single stand. These facilitate the handling of extremely long lengths of metal during these reductions. A common method is the *Belgian* or *looping mill* (Fig. 316) in which the sets of unit rolls are arranged alongside each other, and the bar emerging from one pass is looped around by a catcher, or, automatically, by a *repeater trough*, and started through the next pass. If the section shape is not suitable for looping, a *cross-country mill*, in which several stands of rolls are arranged in trains, or in trains and tandem sets, is used. A *combination mill* is one in which the roughing passes are made in a continuous mill, and the finishing passes in a looping train. The term *merchant mill* is applied to any small mill which regularly produces more than one shape.

#### COLD-ROLLING METHODS

Mills for cold-rolling also may be either *continuous*, *tandem*, or *single stand*, and either forward or reversing. Since their principal purpose is the maintenance of a close dimensional tolerance across the sheet, it is desirable to avoid roll spring as much as possible. Various methods are used for preventing this by increasing the roll rigidity.

For the softer metals, narrower strips, and the less particular reductions,

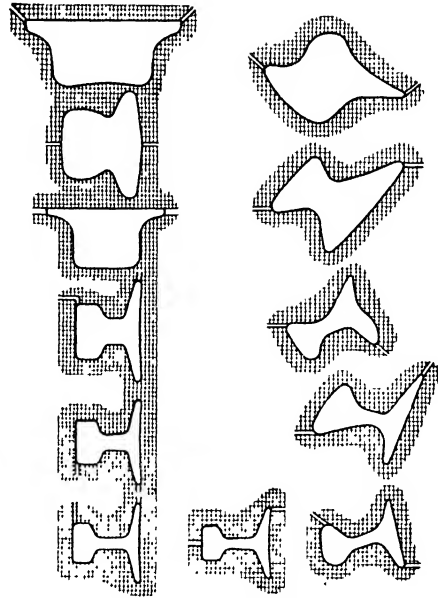


FIGURE 315. Some of the final passes in the hot-rolling of a modern rail section (*bottom center*) by the slab and edging, (*left*) and the diagonal rolling methods (*right*).

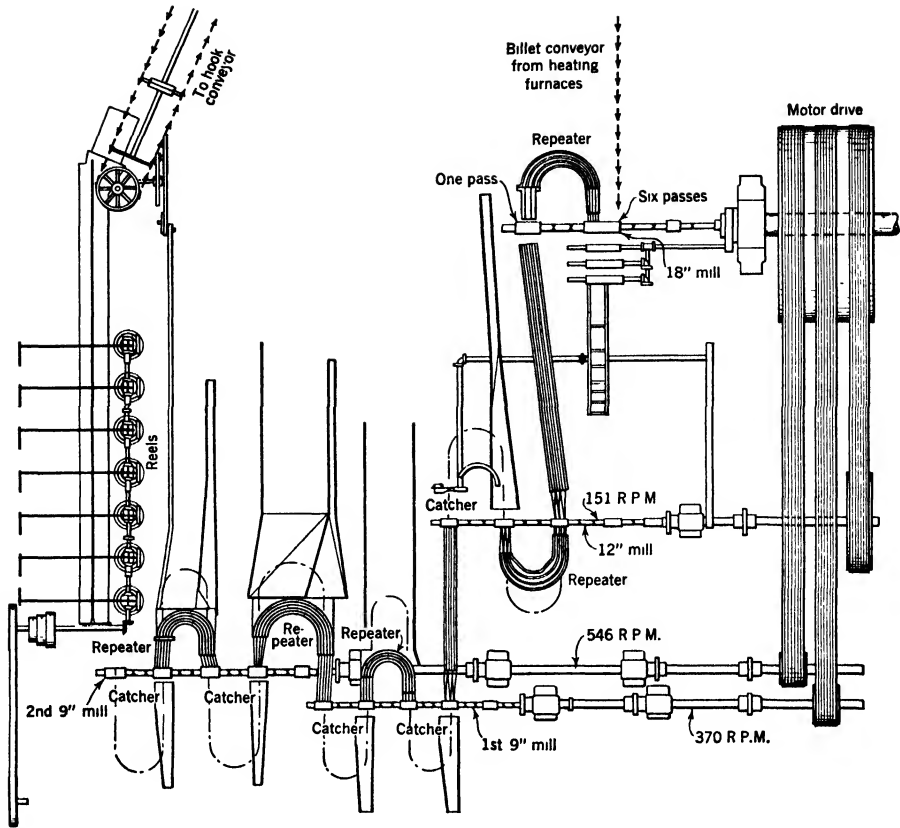


FIGURE 316. A looping mill. Note that both catchers and repeater troughs are used. (From *The Making, Shaping, and Treating of Steel*, by permission of Carnegie-Illinois Steel Corporation.)

ordinary *two-high* or *three-high mills* may be used, because the shorter rolls themselves possess sufficient rigidity. However, for wider sheets the rolls tend to spring apart, so backing-up rolls of larger diameter are usually used to make the smaller working rolls more rigid. With small working rolls, in addition, the separating force is kept small for a given reduction.

Figure 317 shows several of the more common designs. The *four-high mill* has one backing-up roll for each driven working roll, and usually imposes a small tension on the strip by means of coilers or some similar method. The *six-high* or *cluster mill* has two backing-up rolls for each driven roll. If vertical rolls for edge rolling are added, this mill is sometimes called a *universal mill*.

A unique method for continuous rolling is the *Steckel mill*<sup>11</sup> (Fig. 318)

<sup>11</sup> See A. P. Steckel, *Iron Age*, **129**, 1932, 168-171, 214.

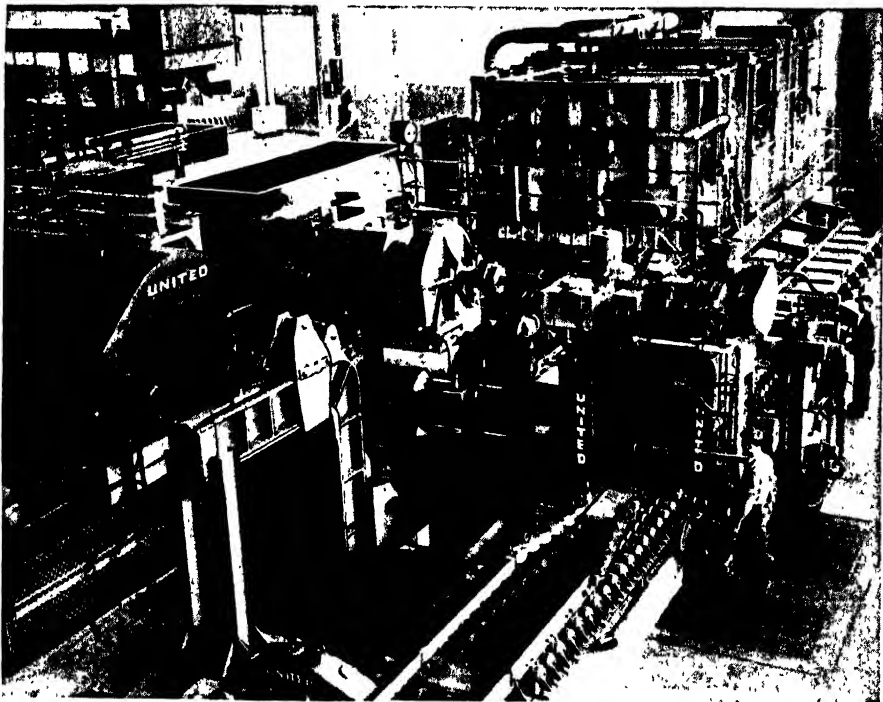
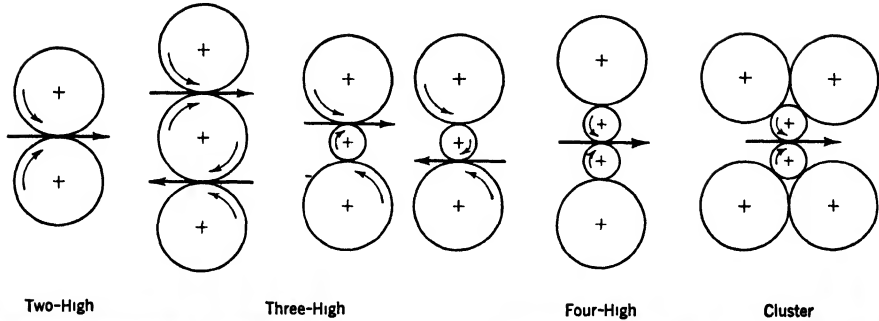


FIGURE 317 *a.* (Upper) Diagrammatic representations of four different types of rolling mills.

*b.* (Lower) Modern two-high hot breakdown mill used in the brass industry. (Photograph courtesy Bridgeport Brass Co.)

which has been used to some extent for both ferrous and nonferrous work. Two small working rolls of highly polished high-speed tool steel are each backed with one much larger roll, made of special heat-treated steel, which is held in place by very heavy roller bearings. All of these four rolls are idler rolls, and are positioned only by a motor or hand-operated screw-down. The sheet to be rolled is *pulled* through the rolls alternately in each



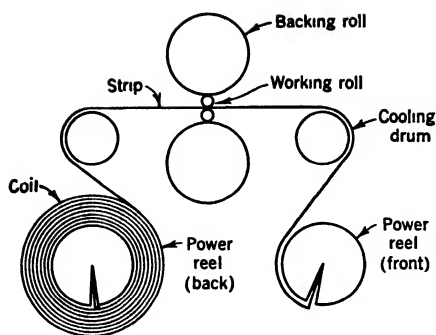


FIGURE 318. Diagrammatic representation of the Steckel mill. (From *Practical Metallurgy*, by G. Sachs and K. R. Van Horn, courtesy American Society for Metals.)

direction. When it emerges from the rolls it is coiled on one of two power-driven reels. These are provided with brakes to exert a back pressure on the strip. The cooling drums are idlers also. This mill has the flexibility of a single-stand mill with respect to the number of passes, and occupies a small floor space. It operates at a higher speed than a single stand, but usually can give less drastic reductions than either the single stand or the four-high reversing mill, because the metal being rolled is always in position and

hence the rolls must be screwed down against its resistance. Its capacity is about a third that of a tandem mill and half that of a single stand.

Metal must be cold-rolled, in general, at a much slower speed than it can be hot-rolled because of its greater resistance to deformation. More power is required for cold-rolling than for hot-rolling, and much more attention must be paid to correct grinding of the rolls and their subsequent wear. Hot or cold water or an oil jet sometimes is directed against the roll surfaces not only to lubricate, but also to utilize the roll thermal expansion for controlling its contour. In modern practice, the tendency is toward continuous mills and synchronized speeds, with automatic and continuous thickness control. This is particularly true of the steel and aluminum industries, the copper and zinc industries still using largely unit operations except in some of the newest plants.

## FORGING

Forging is a much slower process than rolling. However, much more complicated shapes may be made by forging than by rolling, and, in addition, since only a compressive force is exerted in forging, the metal can flow in all horizontal directions unless some method of restriction is imposed.

There are two important methods of forging, *hammer* and *press forging*, which differ principally in the rate of application of the load. In addition, either method can be used with a plain hammer and anvil, or with a tooled die set for shaping the work, as illustrated in Fig. 319. When dies are used, the method is usually called *drop forging*.

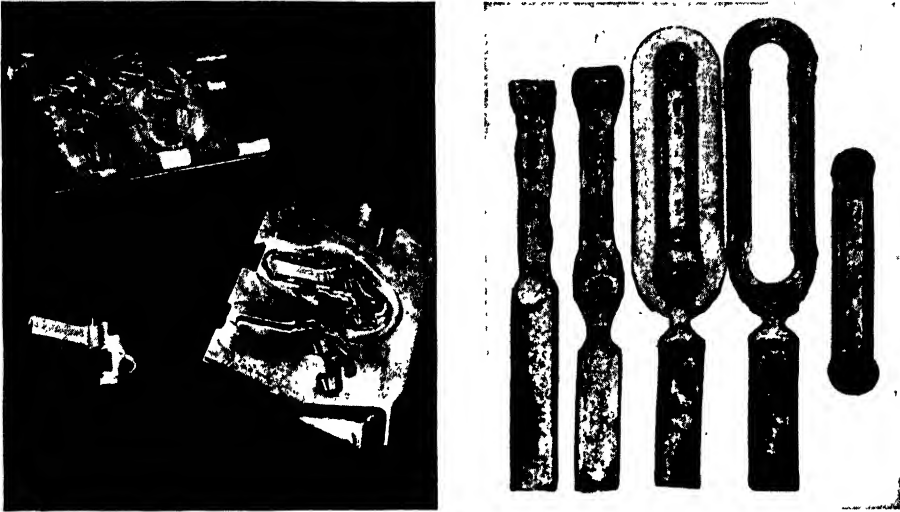


FIGURE 319. (Left) The dies used in forging an aluminum alloy spray gun. (From *Aluminum*, by D. B. Hobbs, The Bruce Publishing Company, Milwaukee, p. 73.)

FIGURE 320. (Right) Various steps in the manufacture of an articulated connecting rod forging for a radial aircraft engine. The overall length of the completed forging as shown by itself on the right is 10 in. Two forgings are made from each 2-in. square multiple cut. One end of the multiple cut is forged and the trimmed flash of the first forging is then used to hold the balance of the stock while the other end is forged. (Courtesy Wyman-Gordon Company.)

#### HAMMER FORGING

Forging hammers may weigh more than 50 tons, and usually are driven on both the up and down strokes so they deliver practically an instantaneous blow. At the forging temperature, the metal is much more resistant, both elastically and plastically, to deformation by this rapidly applied blow than it would be to a slower one. Hence, only the surface layers are severely worked and modified. The impact blows seem to be absorbed by the central portions of the piece almost elastically, and with very little distortion. Moderate blows, if continued long enough, will gradually consolidate the more or less porous center of the piece; but excessively heavy blows even may open a cavity in the center if the piece being forged is large, and is forged cold. Hammer forging is principally used for forgings of smaller sections, where surface refinement is important, and for drop forging.

*Drop forgings*, since they require expensive die work and some prefabrication of the metal, usually by rolling, must be made in sufficient quantity to justify their higher cost. However, as a rule, they have better properties

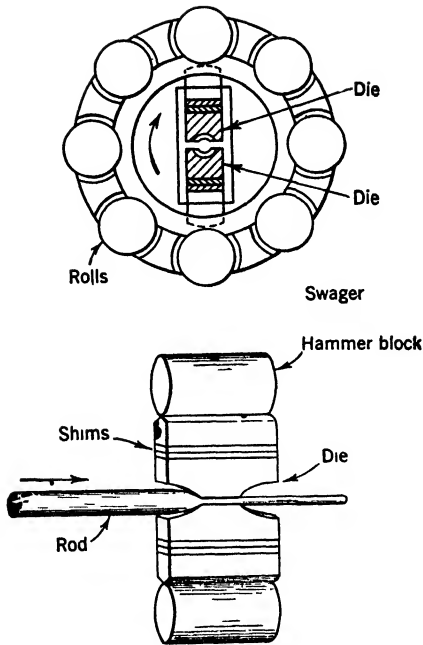


FIGURE 321. Diagrammatic sketch of a swaging machine. (From *Modern Uses of Nonferrous Metals*, A.I.M.E., 1935.)

in the construction and location of the press.

The cost of pressing is less, and the speed greater than for hammer forging. Fewer and less skilled men are required. However, the slower operation tends to press the scale into the surface, whereas the hammer blow tends to knock it off. In general, the press is used for heavy work requiring good physical properties even though, in practice, the applications of the two processes overlap a great deal.

### SWAGING

The process of swaging is a modification of forging in which reduction is accomplished by repeated blows. It may be done either hot or cold, depending upon the metal being swaged. In a common type of rotary machine (Fig. 321) two tapered dies are mounted so that the correct spacing exists between them. The rotation of a series of eccentric rollers then causes these dies to be struck repeated blows which are imparted to the piece being swaged. By turning this it can be shaped into a round.

The process is used for some metals, such as tungsten, in the early stages of reduction from forged rod to wire; and also is used extensively for re-

than castings because of the working they undergo. In Fig. 320 are shown the various stages in the drop forging of an aircraft connecting rod.

### PRESS FORGING

The forging press largely has displaced the forging hammer for heavy work such as armorplate, large caliber guns, cracking vessels for oil refineries, etc., because of the higher efficiency and the more thorough working of the metal from the slower and steadier application of the pressure. Presses today vary between about 3000 and 15,000 tons capacity, the larger sizes predominating. More intricate dies can be used for pressing than for drop forging. The absence of shock is also very important, both in the handling of the forging, and

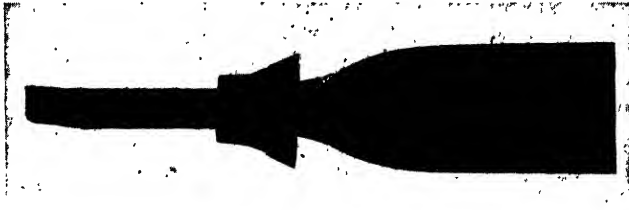


FIGURE 322. Showing how the skelp is bent and welded as it is drawn through the welding bell. (From *The Making, Shaping, and Treating of Steel*, by permission of Carnegie-Illinois Steel Corporation.) The metallographic structure of the joint in a wrought-iron pipe made by this process is shown in Fig. 346c.

ducing the ends of rods, tubes, and other shapes which must pass through a die for further drawing. The principle also is applied in other fabricating methods that have not been too widely used.

#### MANUFACTURE OF TUBULAR PRODUCTS

Pipes, tubes, tubing, and casing, which are used for conveying gases, liquids, and solids, and for a large number of mechanical, and structural purposes, usually are made by one of three methods:

1. *Welding*, the metal first being rolled hot as a strip or sheet and then formed and welded or brazed to form the tube.
2. *Seamless drawing*, the metal being cast as a shell, pierced from a solid billet, extruded from a solid billet, or cupped from a rolled sheet; and then worked to form a tube of desired dimensions.
3. *Shop fabricating methods* such as lock-bar and riveting, which may be done hot or cold depending principally on the alloy, although hot-work is preferred, where possible, because of the lower resistance to deformation.

#### WELDED PIPE

Steel or wrought-iron strip which is to be used for forming pipe is called *skelp*. This usually is made on a continuous mill and of such dimensions that, when it is formed longitudinally, a pipe of the required outside diameter and wall thickness will be produced.

Butt-welded pipe, in sizes of  $\frac{1}{8}$ -3 in. in diameter, is made by drawing heated skelp through a bell-shaped die, which forms it very rapidly into a circular shape and welds it in one operation, as shown in Fig. 322. The welded pipe is compressed and elongated, and formed into an exact circular section in sizing rolls in order to finish it.

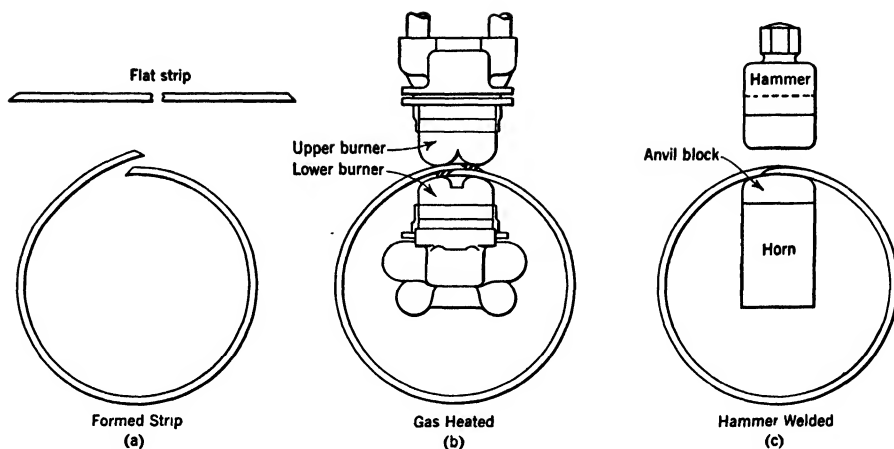


FIGURE 323. Lap welding of steel or wrought-iron pipe under a hammer.

- a. Skelp both before and after forming for lap weld.
- b. Heating edges of skelp for hammer welding using a gas flame.
- c. Welding heated edges under the hammer.

Lap-welded steel or wrought-iron pipe, in sizes from  $1\frac{1}{4}$  in. nominal pipe size, to 24-in. actual outside diameter, is made from skelp, or from plates for the larger sizes. In either case, the edges will be scarfed in the finishing rolls so they will fit together when the skelp is bent into the form of the pipe. The pipe is then bent, and subsequently welded in a few seconds by passing it either through a pair of rolls over a mandrel head or through a welding bell similar to that shown in Fig. 322. Passes through sizing and straightening rolls finish the operation.

Bent skelp more than about 30 in. and up to about 8 ft in diameter may be hammer or forge welded, as illustrated in Fig. 323, frequently using a small power hammer mounted in a stationary position over an anvil supported on a long counterweighted shaft. Usually heat-treatment for grain refinement, followed by straightening, finishes the process. Electric welding, either metal- or carbon-arc and frequently automatic, is also used. Likewise, electrical butt-welding methods are used.

#### SEAMLESS PIPE AND TUBING

Seamless pipe and tubing are made by several processes, the selection depending somewhat on the dimensions and on whether the metal can be worked both hot and cold, or cold only.

A metal such as steel, that can be worked hot more readily than cold, is generally formed first into a cylindrical shape by piercing a solid billet and then worked to smaller sizes on elongating mills and finished by reeling or

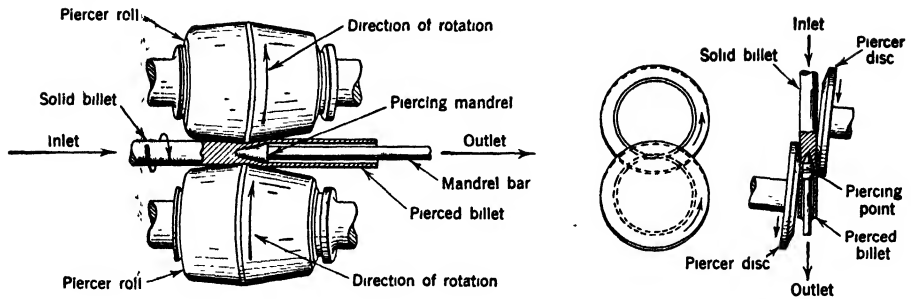


FIGURE 324. The Mannesmann (*left*) and Stiefel (*right*) piercing mills. (Courtesy Pittsburgh Steel Company, and National Tube Company.)

sizing, sizes under  $1\frac{1}{2}$  in. diameter usually being finished by cold-drawing for reasons of economy. On the other hand a metal like copper, which can be worked equally well hot or cold, generally is pierced hot and then drawn cold to the finished size. For some sizes and alloys, cupping or extrusion may be used to replace some of these operations, aluminum alloys in particular usually being extruded into fairly large tubes and then cold drawn to the finish sizes.

Metals that can be worked only cold must be formed first into a cylindrical shape by the cupping or cast-shell processes and then worked down and finished by cold-drawing.

## PIERCING

The general principles of the two commonest piercing processes, the Mannesmann and Stiefel mills, are similar, the two mills differing only in design as can be seen from Fig. 324. The Stiefel mill has disks whereas the Mannesmann mill, which is used much more widely, has rolls which vary from 20–30 in. in length and 32–48 in. in diameter depending upon the size of the tube being made. The axes of these two heavy tapered rolls are inclined at opposite angles of 6–12 deg with the horizontal center line of the mill, and, because they revolve in the same direction, the rolls tend to rotate the piercing billet and to move it forward with a screwlike motion. The amount of angle at which each roll is inclined from the line of travel of the billet determines the speed at which the billet travels through the mill. Because of the manner in which the metal is worked as it passes through the region of closest approach of the rolls there is a definite, although small and irregular, hole formed in the center of the rolled billet. To expand this hole and accentuate the effect, a mandrel rod, with a piercing point on its end, is fixed in position with its tip just ahead of the closest approach of the rolls. The billet thus is forced spirally forward over the piercing point, the entire

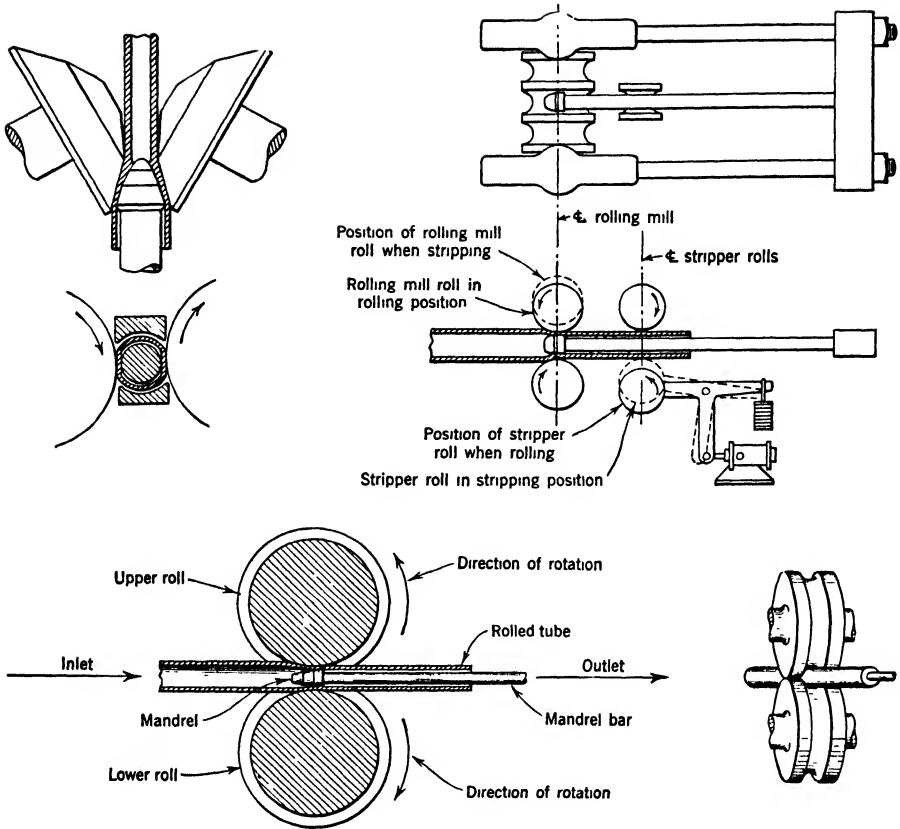


FIGURE 325. Various methods of hot-rolling pipe and tubing.

a. (Upper left) Rotary rolling.

b. (Upper right) The automatic plug rolling mill.

c. (Lower) Tube rolling.

(Figs. 325a, b, courtesy National Tube Company; c, courtesy Pittsburgh Steel Company.)

mandrel rotating with the billet, forming a hollow heavy-walled cylinder somewhat larger in diameter and considerably longer than the original billet. Mills of the Mannesmann type are used also for *expanding* an already pierced shell to a larger size. This combination of piercing and expanding is known sometimes as *double piercing*.

#### TUBE ROLLING

The intermediate operations between piercing and finishing may be carried out by any of several processes. Most commonly used for reducing the wall thickness and lengthening the tube are the various types of tube rolling mills, examples of which are illustrated diagrammatically in Fig. 325.

The *rotary rolling mill*, used for pipe up to 24 in. outside diameter, 45 ft length, and with wall thicknesses greater than 0.281 in., is roughly similar to a piercing mill in principle, and is, in effect, another type of *expanding mill*.

The *plug rolling mill* is a non-reversing two-high tube rolling mill which works semiautomatically. After the blank passes

through the correct groove, and is decreased in outside diameter and wall thickness, it is pulled back through the mill on the return pass by stripper rolls. This does not work the metal as the working rolls are separated.

The other tube rolling mills consist of a two-high stand of rolls each of which is grooved with several different sizes to permit greater flexibility. Each pair of successive grooves is narrower and shallower than the preceding one so that the hot shell may be rolled through them in sequence and over a mandrel or a plug, which is supported in an appropriate position on the exit side, until the length, diameter, and wall thickness approximate those required in the finished tube. The tube is customarily given a 90 deg turn between passes to assist in maintaining a uniform section.

A somewhat different type of tube rolling mill is the *elongator mill* which is used primarily to produce hot-rolled tubes of smaller diameter and lighter walls than are practicable with the other processes. The important features of a typical mill, the *Diescher mill*, are shown diagrammatically in Fig. 326. This mill consists of two cross rolls, inclined slightly to the axis of the tube, and two rotating guide disks. All of these are adjustable. The pressure between the cross rolls and the mandrel bar serves to smooth out variations in wall thickness and to give a smooth inside and outside surface. The final positioning of the four rolls finishes the tube with the desired shape. Because of the smooth surfaces and uniform wall thickness, tubes for boiler and power piping and for mechanical tubing, where the concentricity means better balance, frequently are made by this process.

If steel pipes and tubes of diameters larger than 6 in. are to be made, especially for oil-field service, the *Pilger mill*,<sup>12</sup> (Fig. 327a) may be used. In this mill a pierced shell is reduced hot over a mandrel bar by repeated impact blows of eccentric rolls thus giving a tough structure comparable to that of a forging. The tube is pushed between the rolls which, as they ro-

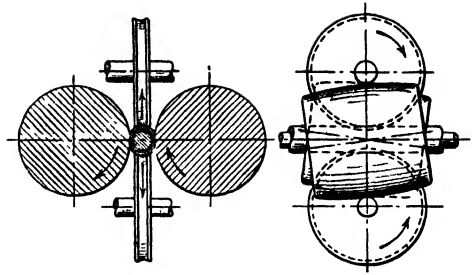


FIGURE 326. The Diescher elongator mill. (Courtesy National Tube Company.)

<sup>12</sup> See W. C. Sutherland, *Yearbook American Iron and Steel Institute*, 1927, 117-131; *Pittsburgh Seamless Steel Mechanical Tubing*, Pittsburgh Steel Co., Pittsburgh, Pa., 1937.





FIGURE 327a. The Pilger mill in operation. (Courtesy Pittsburgh Steel Company.)

successively  $+22\frac{1}{2}$  deg,  $-67\frac{1}{2}$  deg,  $-22\frac{1}{2}$  deg,  $+67\frac{1}{2}$  deg, etc. By rolling the tube over a long, carefully finished mandrel rod the desired inside dimensions can be maintained and the wall thickness and perfection of roundness adjusted accurately. The length of the mandrel bar is the only factor that limits the tube length. After this rolling, the mandrel is removed, and the tube reheated and passed through two successive reducing mills of 13 stands each if it is to finish on the smallest size.

#### HOT-FINISHING OF TUBES

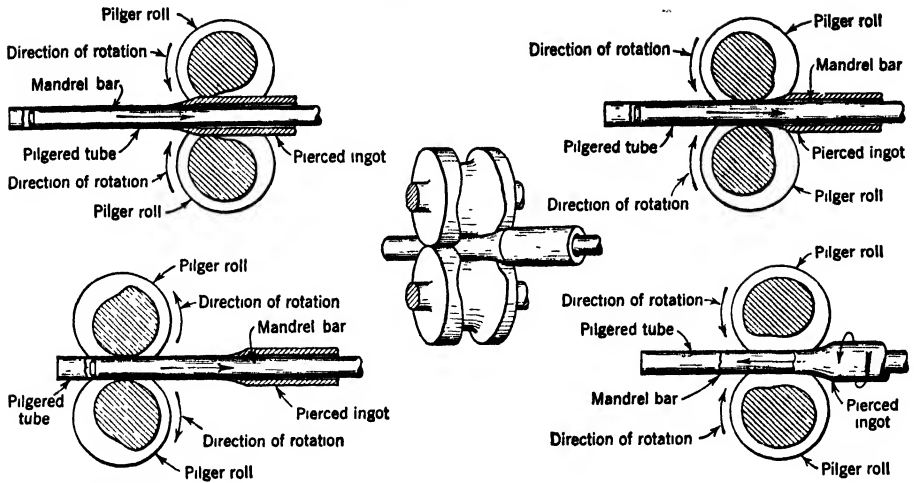
Tubes coming from most of the rolling operations are slightly oval in shape and not perfectly smooth. These defects are corrected by *reeling*. A reeling machine (Fig. 328a) has two rolls, slightly inclined toward the horizontal and flat rather than tapered as in the piercing mills. These cause the tubes to be rotated rapidly as they are forced slowly over the plug and mandrel rod, which rotates with them. The tube emerges round, straight, and burnished, but slightly oversize.

The *sizing mills*, which complete the process for tubes 3 in. and over in diameter, are grooved two-high stands, as shown in Fig. 328b. The tube is rolled through two or more passes, with small reductions, in order to secure a uniform size and roundness.

<sup>13</sup>See R. A. Fiske, *Iron Age*, 133, 1934, 24-27; E. W. Wrage, *Trans. A.S.M.E.*, 64, 1942, 745-751.

tate, give it a heavy impact blow and then smooth it by rolling it backward as far as the mandrel will permit. The tube and mandrel then are rotated mechanically 90 deg and carried forward into the rolls where the tube is again struck a hard blow, rolled out, and thrown back. The finished tubes usually are normalized after coming off the mill to be sure no residual strains remain in the worked metal.

The *Foren mill*<sup>13</sup> (Fig. 327b) can be used to hot-roll tubes of  $1\frac{1}{2}$ - $4\frac{1}{4}$  in. outside diameter with walls as thin as 16 gauge (0.065 in.). In this process a pierced shell is passed through a series of rolls each of which is placed at 45 deg to that preceding or following it, i.e., the angles with the vertical are



a (continued)

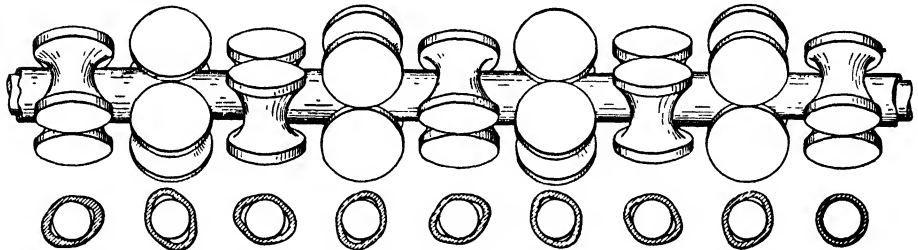
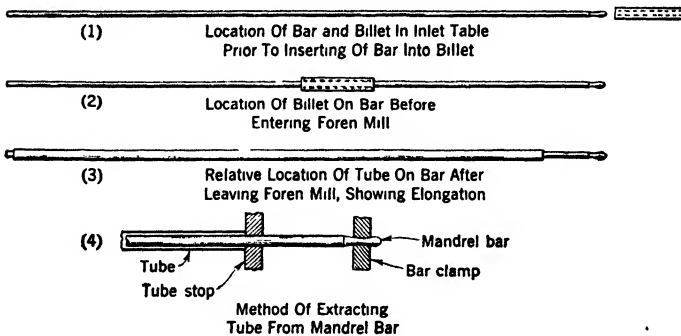


DIAGRAM SHOWING VARIOUS PASSES



b

FIGURE 327a (continued). The Pilger mill, a schematic breakdown of successive stages of operation. (Courtesy Pittsburgh Steel Company.)  
 b. The Foren mill, broken down schematically into the four successive stages of operation. (Courtesy Globe Steel Tubes Co.)

Smaller diameter tubes, in the range  $1\frac{1}{4}$ –3 in., which are uneconomical to finish by reeling and sizing, are *reduced and sized* hot in a somewhat different type mill (Fig. 328c). This process sometimes is called *sinking*. Several

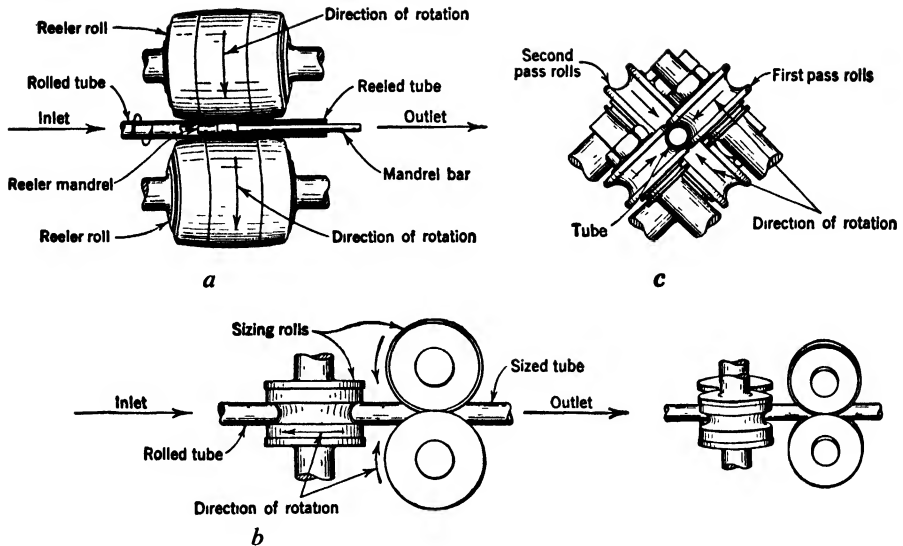


FIGURE 328. Machines for hot-finishing tubing.

a. A reeling machine.

b. A sizing mill.

c. Mill for reducing and sizing, sometimes called sinking. (Courtesy Pittsburgh Steel Company.)

stands of grooved rolls are used in series, each inclined at 45 deg to the vertical and at 90 deg to those preceding and following. Successive passes through these rolls, therefore, will elongate the tube gradually and reduce it to the outside diameter desired. If the speeds of the successive rolls are adjusted properly the wall thickness will remain essentially unchanged, the elongation in length compensating for the decrease in diameter.

### CUPPING

In the production of short lengths of large diameter ferrous seamless tubes and of tubing for gas cylinders, the hot-cupping process, illustrated in Fig. 329, often is used. A plate or blank is placed over the lower die of an hydraulic press and formed first into a closed-end seamless cup. Usually several such operations are needed to draw out the tube to the length desired after which the closed-end cylinder produced may be fabricated further or the closed end may be cut off and the tube drawn to smaller sizes by conventional methods.

In the brass industry the cupping process has been used to some extent for cold-cupping flat plates, of alloys that cannot be hot-worked, into tubes intended for subsequent redrawing. The process is more expensive than its

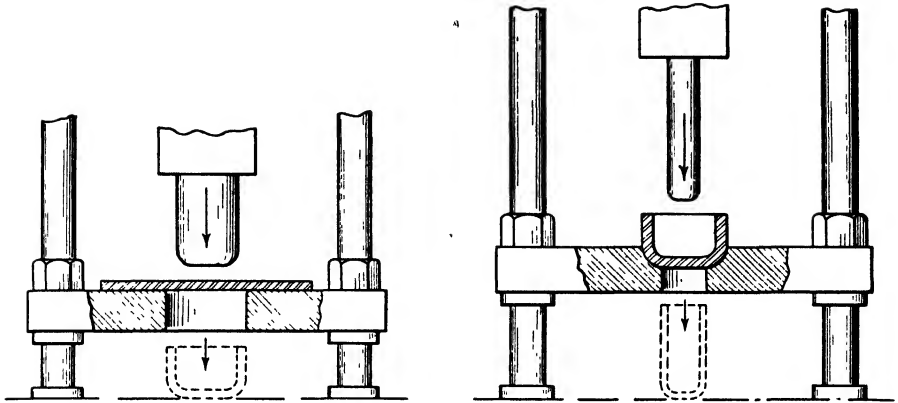


FIGURE 329. The cupping process used in the production of tubing. Diagrams of the first (*left*) and second (*right*) cupping operations. (From *The Making, Shaping and Treating of Steel*, by permission of Carnegie-Illinois Steel Corporation.)

chief competitor, the *cast-shell process*, but has the advantage of permitting a closer inspection and an easier method of securing high-quality inside and outside surfaces.

#### TUBE EXTRUSION

The various tube extrusion processes already have been described. In this country these generally are used only for alloys of copper base or of a lower melting point, but in Europe steel tubes also have been made by this method. It is used primarily for tubes which are to be finished on a fairly small diameter as the presses required must be quick acting and quite powerful. Unless sufficient press power is available, the billet may cool too much before or during extrusion, resulting in excessive scrap loss and die wear as well as poor surfaces.

#### THE CAST-SHELL PROCESS

When hot-work is impossible or uneconomical because of the general characteristics of the tube alloy, the simplest procedure is merely to cast a cylindrical shell of appropriate diameter and wall thickness. This then can be drawn down to the finished size by a series of cold-working operations with softening anneals properly spaced. The reduction used per pass will, of course, depend on the alloy. Care must be taken in the initial "break-down" passes to treat the metal in the manner best able to break up the cored cast structure and to yield an homogeneous structure.

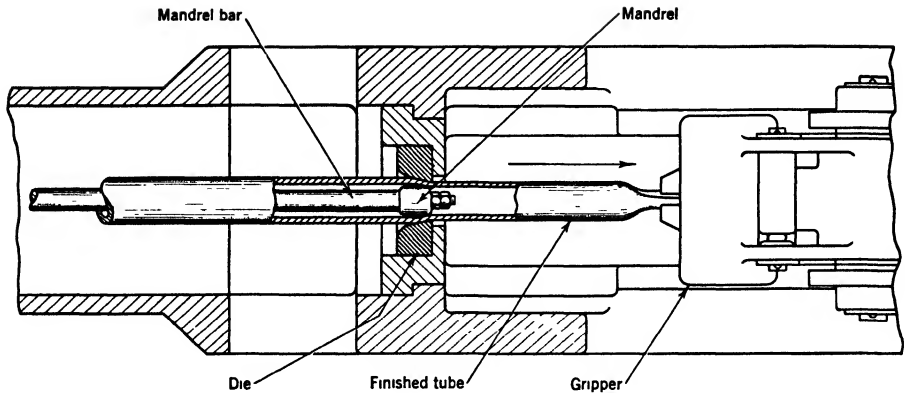


FIGURE 330. Diagrammatic view of drawbench showing seamless tube in the process of drawing. (Courtesy Pittsburgh Steel Company.)

### TUBE DRAWING

When the tube is to be cold-drawn, a drawbench is used similar to that shown in Fig. 330. Tubes first are pointed, pickled and cleaned, and coated with a suitable lubricant by dipping. They then are pushed back over a mandrel rod, so arranged that the plug on its end “floats” in the proper position in the die, and the pointed end of the tube is pushed through the die. Jaws, attached to a movable carriage, clamp on the end of the tube. The hook at the other end of the carriage then is dropped over a link in a power-driven endless chain, and the tube is pulled between the die and the centered plug, thus reducing the outside diameter and wall thickness, and increasing the length.

Cold-drawing of tubes may produce rather high tangential internal stresses which may cause cracking,<sup>14</sup> either from the action of corroding conditions, termed *stress corrosion* or *season cracking*, or on subsequent heating, termed *fire cracking*, unless they are balanced properly. A typical stress-distribution curve is shown in Fig. 331. Balancing these stresses requires a proper relationship between the reduction in diameter and the reduction in wall thickness, which is different for each type of tubing and alloy and must be learned by experience.

### SINKING

Tubing, especially nonferrous tubing in the smaller sizes, i.e., below  $\frac{1}{4}$  in. inside diameter, sometimes is drawn by the process of sinking, without us-

<sup>14</sup> See, for example, D. K. Crampton, *Trans. A.I.M.E.*, 104, 1933, 194–213; J. Fox, *Mech. World*, 94, 1933, 960–961, 1087–1089, 722–723.

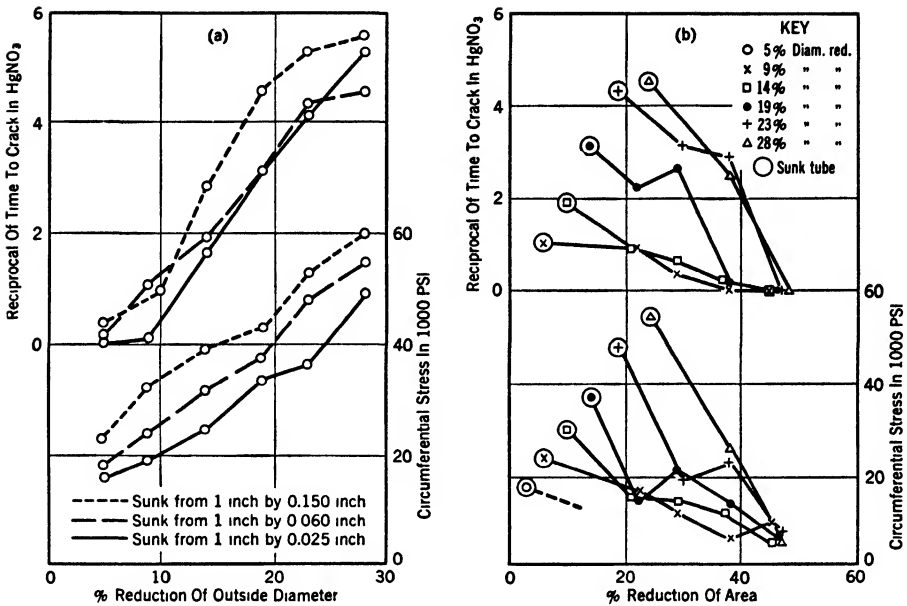


FIGURE 331. Internal stress and tendency to season crack in high brass (66% Cu — 0.3% Pb — 33.7% Zn) tubes as influenced by (left) degree of sink, and (right) area reduction and diameter reduction by drawing and sinking from 1 in. outside diameter by 0.060 in. wall thickness. (From D. K. Crampton, *Trans. A.I.M.E.*, 89, 1930, 246.)

ing a mandrel or plug inside the tube. By this method the outside diameter is reduced with little or no change in the relative wall thickness. In most alloys, sinking tends to increase the unbalanced internal stresses as illustrated in Fig. 331, so frequently raising them close to the danger point that it is avoided wherever possible. Its main application comes in drawing tubing of such extreme fineness or with such a heavy wall that a mandrel could not be inserted, or in drawing long tubes which can then be handled in coil form for redrawing.

• ROD AND WIRE DRAWING

A process identical with tube drawing, except that the mandrel and plug are not needed, is used for the cold-drawing of both rod and wire. In the former case, diameters are relatively large and lengths relatively short so a drawbench similar to that in Fig. 330 can be used. However, the lengths of wire are much greater, and a revolving drum, called a *bull block*, to which is attached a set of jaws, called a *dog*, is used instead (Fig. 332). As diameters decrease, the number of drafts or passes through the die without annealing may be increased and sometimes as many as eight passes are given in a multiple bench (Fig. 333).



FIGURE 332. Typical single pass wire-drawing bull block suitable for wire about  $\frac{1}{2}$  in. and finer. (Courtesy Morgan Construction Company.)

The process of rod drawing, in particular, is apt to result in comparatively high internal stresses, as illustrated in Fig. 334. However, it is common practice to finish all rods by one or more passes through one of the various types of straightening machines. By this means the internal stresses are so broken up and balanced that the danger of spontaneous cracking from corrosion or sudden heating is practically eliminated.

#### THE COLD-FORMING OF METALS

Many methods are used for the cold-forming of ductile metals. The processes involving cold extrusion have already been described.

In *stamping*, the shape of the piece is changed by one or more rapid blows of a press. Modifications of this are *embossing* (Fig. 335) in which various designs are impressed on an article with an extensive surface area, and *coining*, in which a similar process is used, but only to form a design on the surface itself (Fig. 336). The method of cupping, as used for making tubing, has already been mentioned. When carried out to a greater degree, forming deeper cups as in the production of shell and cartridge cases, it is known as deep-drawing. Various stages in the production of a 90-mm

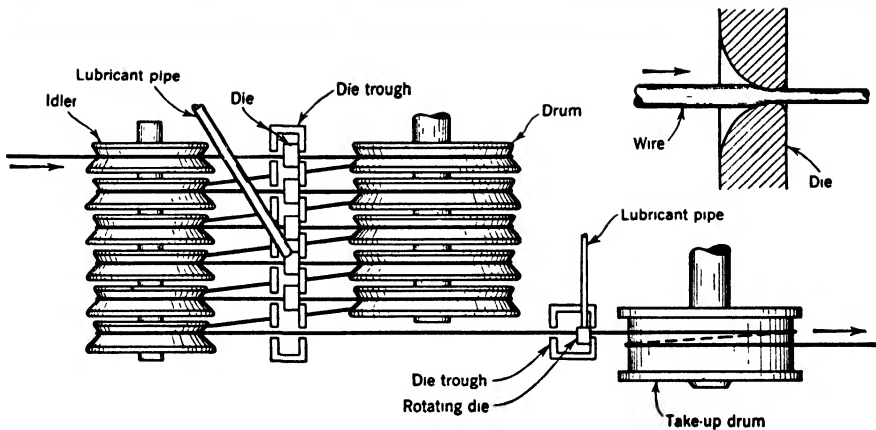
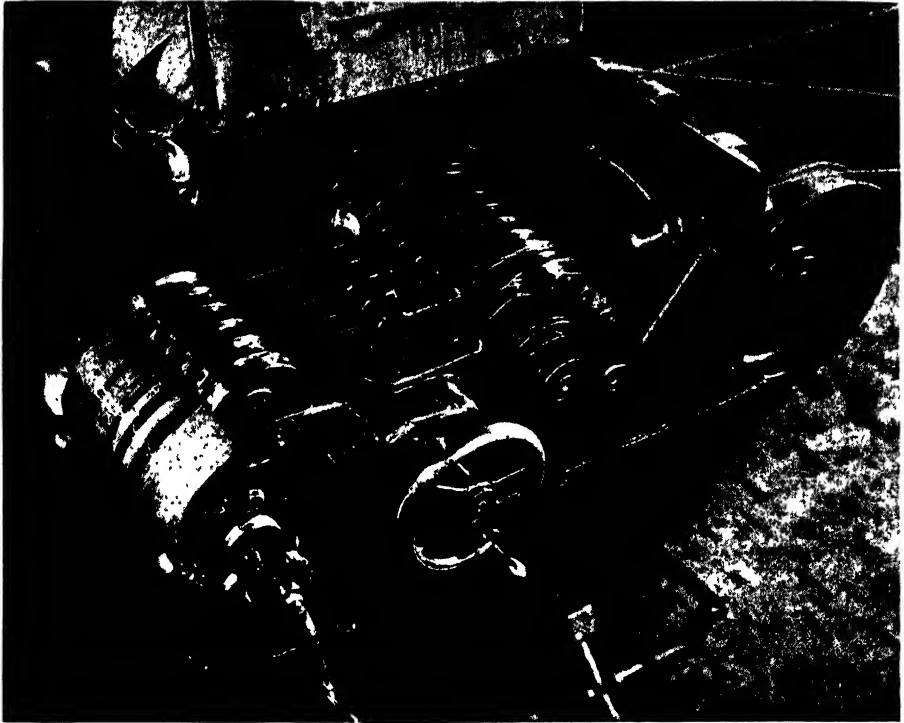


FIGURE 333. A continuous wire-drawing machine. (From *Aluminum*, by D. B. Hobbs, The Bruce Publishing Company, Milwaukee, p. 64.)

shell casing are illustrated in Fig. 337a. The term *deep-drawing* also is used in the steel industry to designate the forming of such things as automobile fenders or body sections by presses, acting at various speeds, usually slow.

In making deeper cups several drawing operations may be given in suc-



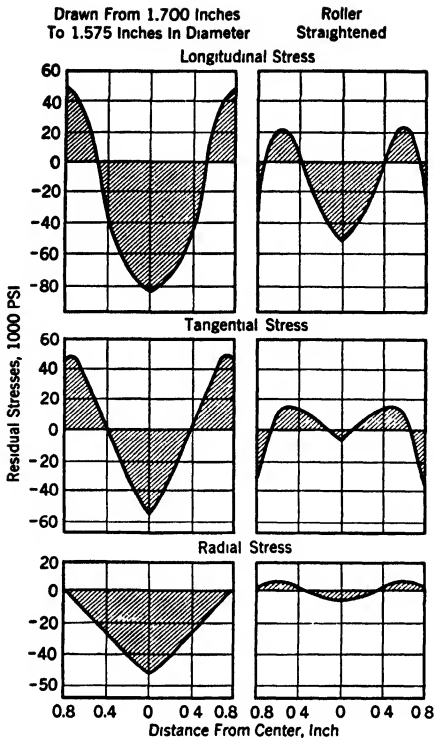


FIGURE 334. Residual stresses in drawn Bessemer steel rods before and after straightening. (From *Practical Metallurgy*, by G. Sachs and K. R. Van Horn, American Society for Metals.)

cession, either with or without intermediate anneals to remove the effects of work-hardening. These successive operations are usually termed *redrawing* and may be of several types, as illustrated in Fig. 337b.

In the process of *spinning* (Fig. 338) a disk of metal is rotated at high speed and formed into a hollow vessel by pressure of a suitable tool against it. Dished ends on pressure vessels and similar shapes frequently are made by this method.

Less severe operations are the *bending* rolls used for forming sheet that subsequently is to be welded into tubes (Fig. 339) and the various methods of *flattening* and *straightening*. In bending, three rolls are so arranged that the entering sheet is started in bending to the correct radius. It automatically continues on this radius, forming a coil if a long enough length is treated. Similar methods are used in rolling,

therefore, for the automatic coiling of stiffer sheets.

Several methods of straightening are used for sheet, the most common of which are *roller leveling* and *stretcher* or *patent leveling* (Fig. 340). In roller leveling the sheet is flexed up and down alternately as it passes through the rolls, thus working the surface somewhat more than the interior. It may be done either hot or cold. Proper adjustment of the roller positions must be made to secure a flat sheet. Stretcher leveling produces a flat sheet by gripping the ends between jaws, and stretching just beyond the yield point (1–2% elongation). In this manner any slack, which may be present in the form of waves or buckles, is taken up. This method is limited, of course, by the mechanical properties and physical dimensions of the sheet. Sheets that are too weak or too strong, too thick or too thin, usually are difficult to stretch. The method also is not readily applicable to metals possessing a true yield point, since these metals tend to flow spontaneously when the yield point is exceeded. This results in *stretcher strains*, *worms*, *Lueder's lines*, or some of

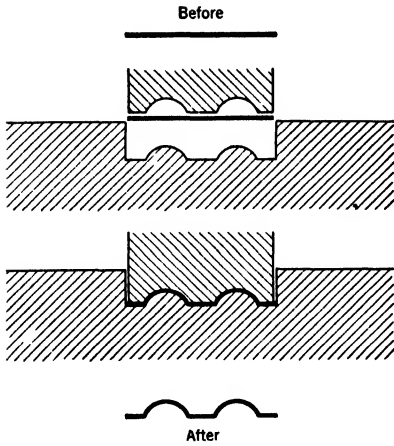


FIGURE 335. (Left) Embossing.

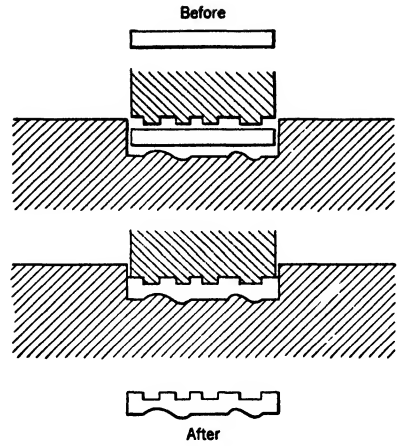


FIGURE 336. (Right) Coining.

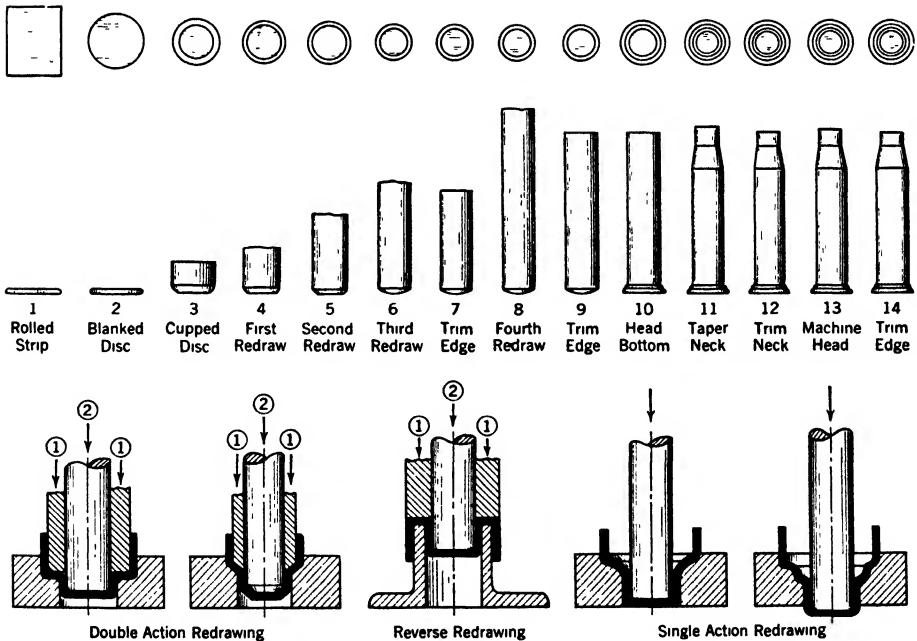


FIGURE 337a. (Upper) Mechanical operations in the fabrication of 90-mm brass shell cases from rolled strip.

b. (Lower) Diagrammatic representations of the different types of redrawing operations. The numbers indicate first or second stage of the operation.

(Courtesy Copper and Brass Research Association.)

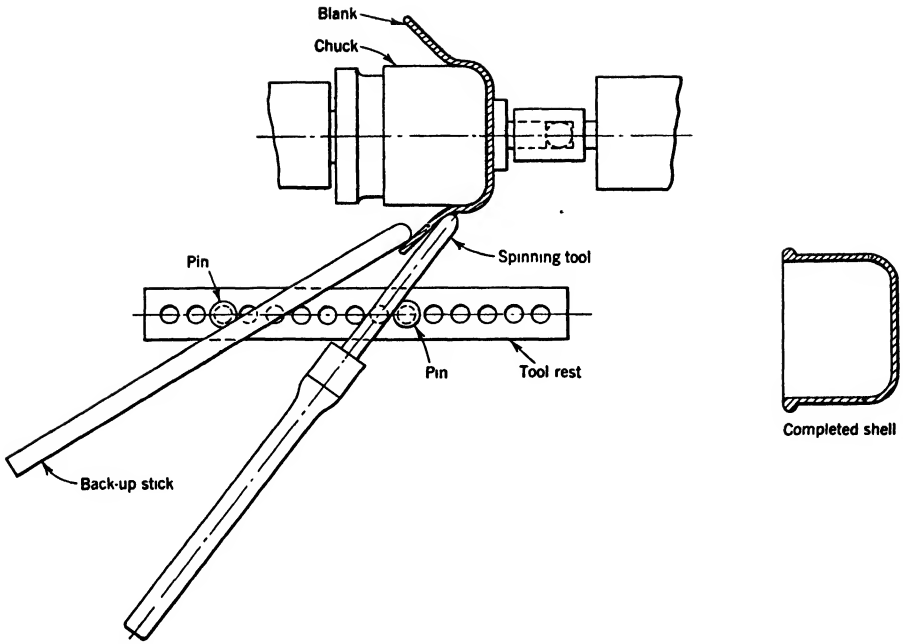


FIGURE 338. Tool arrangement for spinning. (From *Aluminum*, by D. B. Hobbs, The Bruce Publishing Company, Milwaukee, p. 108.)

the other terms used to describe this defect, some examples of which are illustrated in Fig. 388a.

Rods or tubes may be straightened either by hand or by methods similar to those used for roller leveling, except that rolls containing grooves of proper dimensions (Fig. 340b) are used instead of the long rollers. Usually, the machine has two sets of rolls which flex the tube or rod in two planes at right angles to one another.

For hard-drawn rods and some tubular products the *Medart* method is used sometimes (Fig. 341) not only to straighten but also to relieve some of the internal stresses existing in the material as shown in Fig. 334. In this method two tapered and inclined rolls which are similar to the rolls used in the Mannesmann piercing mill, except that they are highly polished and are ground somewhat differently, are used. The rod, pulled through by the rolls with a screwlike motion, emerges straight, provided the adjustments have been properly made.

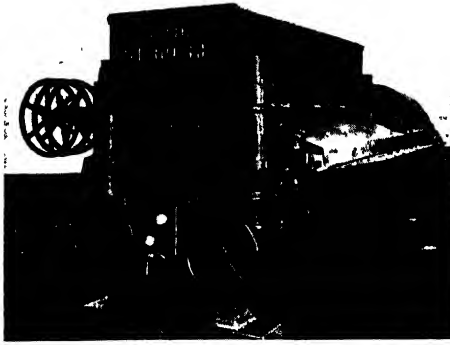
#### POWDER METALLURGY

By molding properly proportioned mixtures of suitable metal powders under pressure and then sintering these compacts, in the correct tempera-

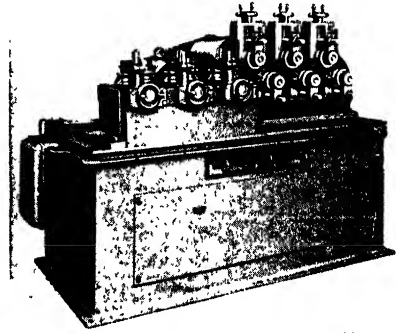


FIGURE 339. Roll forming equipment. (From *Aluminum*, by D. B. Hobbs, The Bruce Publishing Company, Milwaukee, p. 98.)

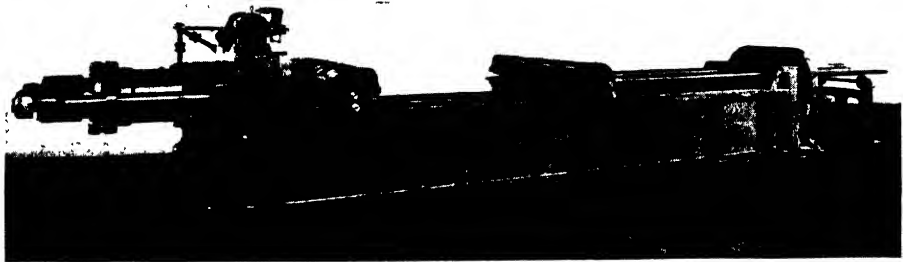
ture range and, preferably, in a reducing atmosphere, coherent parts can be produced having characteristics which are impossible to secure by other means and which are suited particularly well to certain types of applications. Numerous small parts made by this process, the techniques of which now are known as *powder metallurgy*, are illustrated in Fig. 342. The



a



b



c

FIGURE 340. Methods used to flatten and straighten sheet.

a. (Upper left) Roller leveler having seventeen working rolls,  $3\frac{1}{2}$  in. diameter by 84 in. face, and one pair of entering pinch rolls  $6\frac{1}{4}$  in. diameter by 84 in. face. This machine will level steel plates 0.0313 — 0.187 in. thick by 78 in. wide.

b. (Upper right) Twelve-roll straightening machine for tubes and rods.

c. (Lower) A 500,000-lb. stretcher leveler, capable of leveling aluminum and aluminum alloy sheets 60 in. wide by 144 in. long.

(Figs. 340a, c, courtesy Aetna Standard Engineering Company; Fig. 340b, courtesy Torrington Manufacturing Co.)

various aspects of the method are discussed thoroughly in several recent publications.<sup>15</sup>

The process itself is not new but its commercial use on a mass-production basis and the metallurgical understanding of it are. Tungsten wire for lamp filaments, cemented metal carbides for tools, self-lubricating bearings, diamond-impregnated grinding and cutting wheels, metal powder reinforced brake bands and clutch plates, new and strong permanent magnets, and numerous types of electrical contacts all have been made possible through this method of fabrication.

<sup>15</sup> See, for example, *Powder Metallurgy*, edited by John Wulff, American Society for Metals, Cleveland, Ohio, 1942; *Principles of Powder Metallurgy*, by W. D. Jones, Longmans, Green and Company, New York, N. Y., 1937.

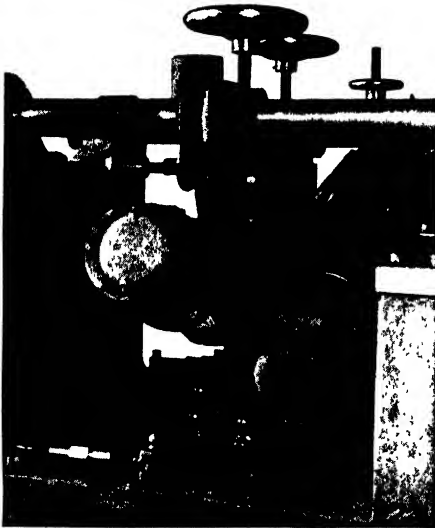
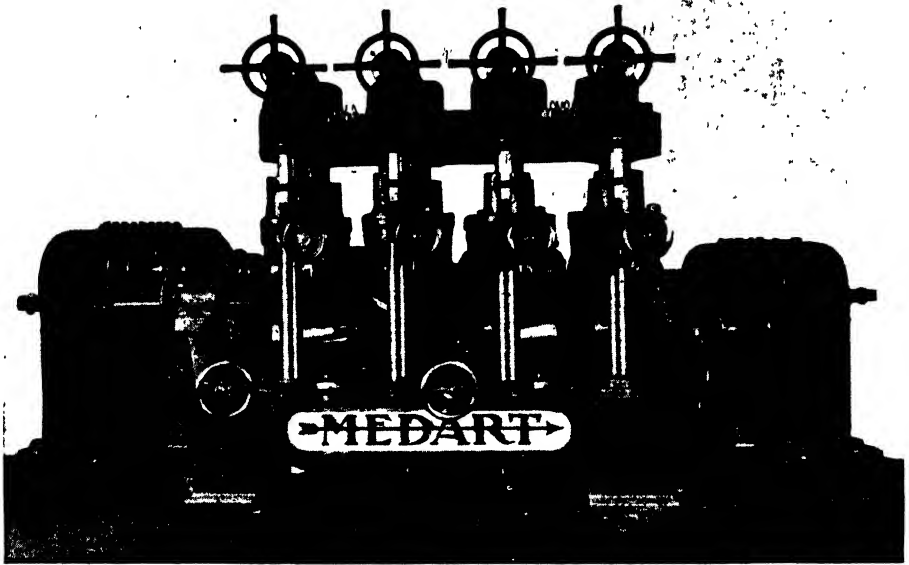


FIGURE 341. The Medart method for straightening hard-drawn rods.

*a. (Lower)* Round bar passing through a two-roll straightening, sizing, and polishing machine.

*b. (Upper)* Latest type of multicycle six-roll straightening machine for tubular products.

(Courtesy The Medart Company.)

Probably the most important characteristic of parts made by this method is their ability to combine certain physical and mechanical properties with almost any density desired merely by controlling the composition and the conditions of manufacture.

## PRODUCTION OF POWDER

Powders usually are made by one of five different methods, depending largely on the allowable cost, the characteristics desired, and the metal used.

1. *Milling* can be used directly for brittle friable metals to make powder of almost any degree of fineness. Any of the common types of mills such as stamping, jaw crushers, gyratory crushers, rolls, disk mills, impact mills, or ball mills may be used. Milled powders are angular or irregular in shape and generally are not suitable for molding unless mixed with a softer powder which acts as the compressible constituent.

Malleable metals tend to produce flakes when milled, provided enough lubricant is present to keep them from welding together. Because of the presence of this lubricant and the general elastic properties of an aggregate of flakes, this type of powder generally is used for paints and pyrotechnics, rather than for molding.

2. *Atomizing* is used extensively for the low-melting metals such as lead, tin, zinc, cadmium, and aluminum. In this method the metal is forced through a small orifice and broken up by a stream of compressed air which also immediately solidifies the droplets produced. The size of the particles is determined largely by the temperature of the metal, the pressure and temperature of the atomizing gas, and the rate of flow through the orifice. The oxygen content of powders produced by this method, using compressed air, will seldom exceed 0.3%. Particles of powder produced in this manner are shaped roughly like a teardrop and can be used in practically any field in which the flake powder is not essential.

3. *Condensation from a vapor* may be used either by direct condensation from a distilled vapor, in the manner already described in the chapter on the production of zinc, or by decomposition of a metal carbonyl in a manner similar to that used in the Mond process for making nickel. Both iron and nickel powder commonly are produced by this latter method, but its comparatively high cost is a serious disadvantage. Powders produced by this method are composed of almost perfectly spherically shaped particles, which can be made of almost any fineness desired.

4. *Reduction of compounds of metals* is particularly suitable when the compounds are friable and can be milled to the proper size before reduction. Reduction of metal oxides by hydrogen or other reducing agents is the most common example of this method. The particles produced are quite spongy in structure and are ideal for molding. Tungsten, molybdenum, copper, nickel, cobalt, and iron powders commonly are

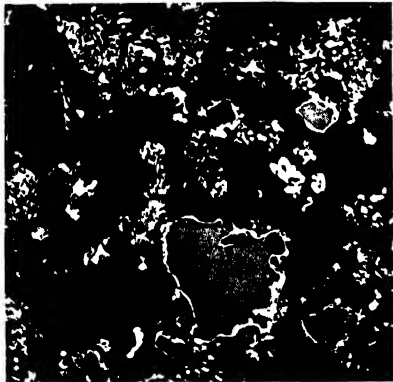
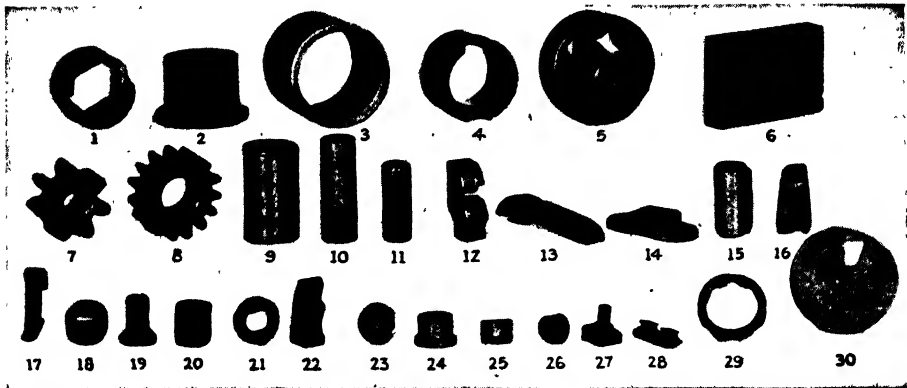


FIGURE 342a. (Upper) Miscellaneous parts made from pressed powders. (Less than one third actual size.)

1, 3, 9, 10, 11, 18, 19, 20, and 24: Bronze bearings and bushings of the self-lubricating type.

2 and 4: Self-lubricating bushings made from iron powder.

5 and 7: Automatic oil pump iron parts.

6: Block composed of alternate layers of compressed iron and bronze.

8: Self-lubricating iron gear used in G.E. electric washer.

12, 21, 23, 25, 27, and 30: Miscellaneous parts made from mixtures of copper and tin powders.

13, 14, 16, 17, and 22: Iron dovetails and brackets, chiefly automotive.

15: Self-lubricating spline bearing made from iron powder.

26: Porous bronze cone used as an oil filter, to replace one made of ceramic material.

28: Cutter for G.E. Disposall unit. Made of Carboloy powder.

29: Bronze bearing race.

(From *High-Production Methods for Metal Parts*, courtesy General Electric Company.)

b. (Lower) Metallographic structures of commercial iron powders, oxide reduced (left), electrolytic (right). Etched with nital.  $\times 200$  originally; reduced about one third in reproduction.

Note that the larger particles in the oxide reduced powder apparently have been reduced (white zone) only at their surface and that their centers are still largely oxide.



so produced. Fig. 342*b* illustrates the metallographic appearance of particles of iron powder made by this method.

5. *Electrolytic deposition* is used for producing both copper and iron powders as well as a number of others of lesser importance. By properly controlling the electrolyte, current density, temperature, and purity of the bath the metal can be deposited directly either as a powder or as a brittle cathode (usually embrittled by the codeposition of hydrogen) which then can be ground to powder and annealed to soften it. The structure of electrolytic powder is characteristically crystalline and generally dendritic or fernlike. It is usually furnaceed and ground to reduce the voids and make it flow better when it is used for molding. Figure 342*b* shows also the metallographic appearance of particles of a commercial electrolytic iron powder.

### MOLDING

After the powders to be molded have been thoroughly mixed in the proper proportions they are compressed into the desired shape. In this process it must be borne in mind that the die design is extremely important. *Metal powders do not behave like a liquid* in the die and, unless the design is correct, uneven shrinkage will result during sintering. The die cavity should be at least two or three times the height of the compact to permit sufficient powder to be placed in the die initially. In addition, clearance between the punch and the die wall must be controlled, usually closer than 0.001 in., so that there is sufficient allowance for entrapped air to leave without permitting the powder to flow between the die and the punch, thus jamming them. Slight tapering of the ejection side of the die also is desirable to prevent cracking of the molded compact during ejection.

Pressures in commercial use for molding may range from 10,000 to 100,000 psi or higher, and are limited by the die steels and the presses available. The optimum pressure for any part must be determined by trial. However, it is found generally that extremely heavy pressures are undesirable and that, over a considerable range, moderate pressures have little real effect on the final density. Hence it is necessary merely to use sufficient pressure to yield a compact which will be dense enough to be handled without damage. Hot-pressing also is used, but as yet not to any extent on a commercial scale although a modification, sintering under pressure, is used by a few concerns.

After molding and heat-treating, or sintering, the parts are frequently put through a sizing or finishing operation. The desirability of and necessity for

this depends on the part and the effect of the sintering operation on the dimensions.

### SINTERING

In the sintering or heat-treating operation three factors are important and must be controlled: (a) temperature, (b) time, and (c) atmosphere. Homogenization of the molded compact takes place only as a result of intermetallic diffusion. It has been pointed out already that the rate of this diffusion increases with temperature and that the approach to an homogeneous state depends upon the time available. Atmosphere control is important in order to minimize chemical reactions, such as oxidation, which might interfere with the surface of contact and thus with the diffusion process. In general, it may be said that there is an optimum range of sintering temperatures for securing the density desired in the final part. This range may or may not be above the melting point of one or more of the components of the mix, but it can only be determined by actual trial. The effect of time in the correct temperature range is not too important as long as maximum density is not desired. Quite long sintering times are generally needed to produce the maximum density. In modern plants sintering is carried out continuously so all three factors are under close control.

### *Methods for Adding and Joining Metal*

The joining of metal parts is carried out chiefly by means of five general types of processes, the first four of which are similar in most respects, and differ mainly in the melting point of the joining material. Additional information on these processes, chiefly of a metallurgical nature, is given in Chap. XX.

1. *Soft soldering*, which generally employs alloys of tin and lead having relatively low melting points, gives a joint having relatively poor mechanical properties.<sup>16</sup> The uses of this method are determined not only by the strength, but also by the relatively poor corrosion resistance of the joint.
2. *Silver brazing*<sup>17</sup> uses alloys of silver, generally with copper and zinc (or cadmium). These alloys melt at much higher temperatures, and give a joint which has much better mechanical properties and a greater corrosion resistance than the soft solders. This process is also known as *silver soldering* or *hard soldering*. In general, the strength of a silver-

<sup>16</sup> See also Chap. 14 C of Ref. 16 at the end of this chapter.

<sup>17</sup> See also Chaps. 14 A and 14 B of Ref. 16 at the end of this chapter.

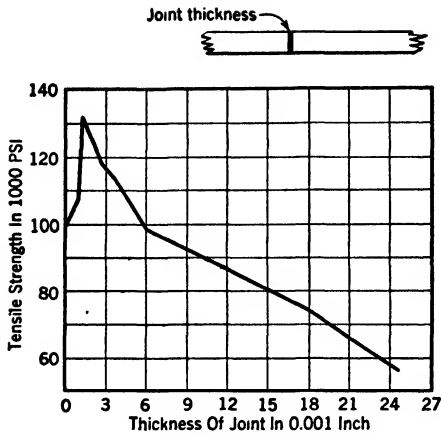


FIGURE 343. Relation of joint thickness to tensile strength based upon butt joints of stainless steel to stainless steel with grade 12 silver brazing alloy. (From American Welding Society Handbook, 1942 ed.)

brazed joint, as well as that of any soldered joint, tends to increase as its thickness decreases, as illustrated in Fig. 343.

3. *Bronze welding*, which usually is referred to simply as *brazing*, utilizes alloys of copper and zinc, sometimes with small additions of other elements. These alloys melt at still higher temperatures. A joint made by this method will possess better mechanical properties than one made using the lower temperature methods, but its corrosion resistance depends to a large extent on the metals it joins

together. An interesting modification of this method is the use of *copper brazing*<sup>18</sup> in a hydrogen atmosphere, with preplaced metal. This method usually is carried out automatically and gives a rather strong joint.

4. *Welding*, which covers a variety of processes, using alloys similar to the base metal, frequently with some compensations for oxidation during melting. This method gives a joint usually having a structure and properties comparable with those either of a casting or of a hot-worked metal, depending upon the type of process used.
5. *Riveting*, in which two plates are fastened and held together by inserting rivets through holes in each and then driving a head on one side of the rivet against a backing-up tool. An etched cross section of a poorly driven rivet is shown in Fig. 344, to give some idea of the metal flow that occurs. Although riveting is an old, widely used, and accepted method of joining structural members, it has definite disadvantages, especially in modern lightweight construction. Metal must be punched out of the plates to make rivet holes, thus decreasing the effective cross section. The riveting might be faulty and as a consequence the rivet might not fit tightly or well, something that is comparatively difficult to detect. Furthermore, other things being equal, a riveted joint is considerably heavier than a welded joint having the same strength.

An interesting development in the riveting of aluminum alloys in par-

<sup>18</sup> See, for example, Chap. 14 D of Ref. 16 at the end of this chapter.



FIGURE 344. Deeply etched section of a longitudinal seam of a poorly riveted joint taken, after 30 yr service, from a boiler constructed before 1900. Note offset head and corrosion from external surface (*top*). Etched with a boiling solution of 50% HCl — 50% H<sub>2</sub>O.  $\times 1$ ; reduced somewhat in reproduction. (Courtesy The Babcock & Wilcox Company.)

ticular is the use of *explosive rivets* (Fig. 345). In some “blind” locations a backing tool cannot be used because of space limitations. Explosive rivets may then be placed and “driven” by applying heat to explode the charge. The percentage of defectives is said to be very small.

The processes of soldering and silver brazing require principally (*a*) a method of securing a high enough temperature to cause the solder to flow on the base metal, and (*b*) a flux to ensure a clean surface of contact by dissolving any oxides that may form and by flowing away when the solder is applied.

Any of the soldering and brazing operations may be carried out automatically with preplaced solder, as the pieces move through a heat-treating furnace held at the correct temperature. In any of them either gas or electric heating may be used.

#### OTHER METHODS OF ADDING METAL

In addition to the above five methods both the *electrodeposition* and *metal-spraying* processes, which are discussed more completely under the heading of coatings giving protection against corrosion, in Chap. XII, are frequently used to build up worn spots on shafts and similar articles.



FIGURE 345. Principle of explosive aluminum rivet, used chiefly in locations not readily accessible for backing up.

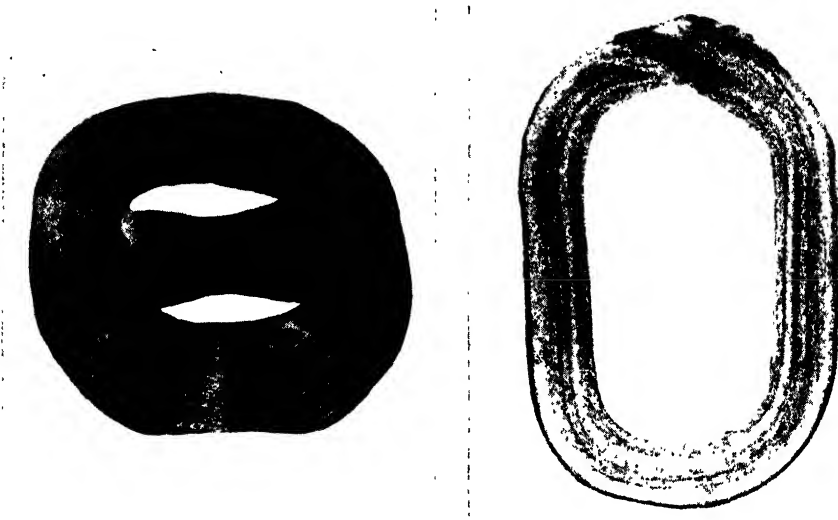


FIGURE 346. Sections through typical forge-welded joints.  
*a.* Macroetched sections of forge-welded wrought-iron chain. *Left*, modern, made from Byers-Aston iron. *Right*, chain made in early part of century from hand-puddled iron.

#### COMMERCIAL METHODS OF WELDING

There are six general processes for welding in common use today:

- |                                       |                                   |
|---------------------------------------|-----------------------------------|
| 1. <i>Forge</i> welding               | 4. <i>Gas</i> welding             |
| 2. <i>Thermit</i> welding             | 5. <i>Atomic-hydrogen</i> welding |
| 3. <i>Electric-resistance</i> welding | 6. <i>Electric-arc</i> welding    |

#### FORGE WELDING

Forge or fire welding is the oldest of the six processes, having been used by the blacksmith for thousands of years. The metal to be joined is first heated in a forge to the welding temperature, and then welded by hammering on an anvil. Because of the very nature of the process, it is not suited for production methods, and hence today finds a limited application, being largely displaced by one or more of the other methods. The process of making welded tube by drawing through a bell is essentially similar, however.

Wrought iron and the low-carbon steels are the materials most frequently joined by this method. When properly made, a forge-welded joint can be as strong as the base metal, because the hammering during welding tends to reduce the large grain size resulting from the high preheating temperature required to secure a weld. A cross section through a typical forge-welded joint in a wrought-iron chain link is shown in Fig. 346.

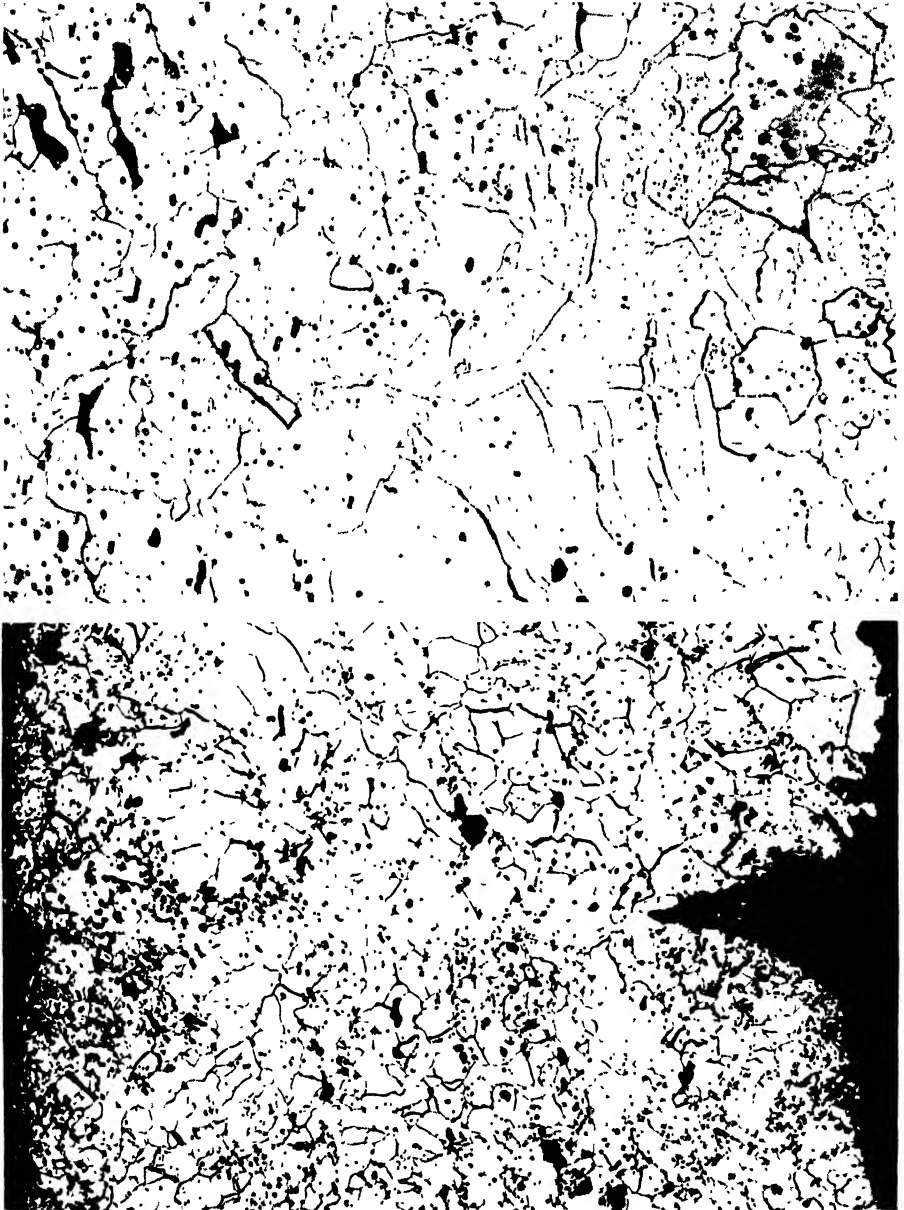


FIGURE 346 (continued) *b.* (Upper) Microstructure along weld zone. Because of high welding temperature the grain structure is somewhat coarsened in the weld zone. Etched with nital.  $\times 100$ .

*c.* (Lower) Microstructure of junction line of butt-welded wrought-iron pipe. Notice the grain refining effects of even the relatively light pressure obtainable by this method. (Courtesy A. M. Byers Co.)

It is customary first to *upset* by hot-working the ends of the bars to be welded together before they are heated to the welding temperature. During this preheating, to a temperature just *under the solidus line*, the grain size is coarsened. However, because of the preliminary upsetting, sufficient excess material is available to permit considerable hot-working after welding, and thus to produce an appreciable refinement of the grain size in the weld zone. Heat flow from the welded section toward the cooler ends of the bar will tend to result in a coarsening of the grain size until such a point that the critical temperature for that alloy is reached. Beyond this no further change will take place. Because of the hot-working at the joint itself, the most likely place for fracture to occur is at the edge of the hot-worked zone, where the grain size has been appreciably coarsened by heating without being refined by subsequent working. The fact that this section, which is weakest because of its coarsened grain size, may be an appreciable distance away from the welded joint, has given rise to the statement that *the weld is stronger than the base metal*. Actually, of course, the weld is only stronger than that portion of the base metal which has been weakened by the pre-heat-treatment incident to the welding operation, but has not been refined by the subsequent hot-working.

#### THERMIT WELDING

In the early part of the present century, Dr. Hans Goldschmidt developed the process of Thermit welding by applying the chemical reaction which now bears his name:



In using this process, powdered aluminum and iron oxide first are mixed together thoroughly. The reaction between these two is strongly exothermic; and, once started by flashlight powder (finely divided magnesium), by magnesium ribbon, or by a special ignition powder composed largely of barium peroxide, it will generate sufficient heat to produce molten steel at a temperature approximating 4500 F (2500 C). This molten metal can be tapped into a mold previously prepared around the parts to be welded.

The setup generally used is indicated in Fig. 347. It is advisable to pre-heat the parts to be welded as this facilitates proper fusion of the edges of the joint. The field of application of the Thermit process is limited somewhat because it requires specially prepared containers, mixtures, and molds. However, it is used throughout industry for repair purposes and for weld-

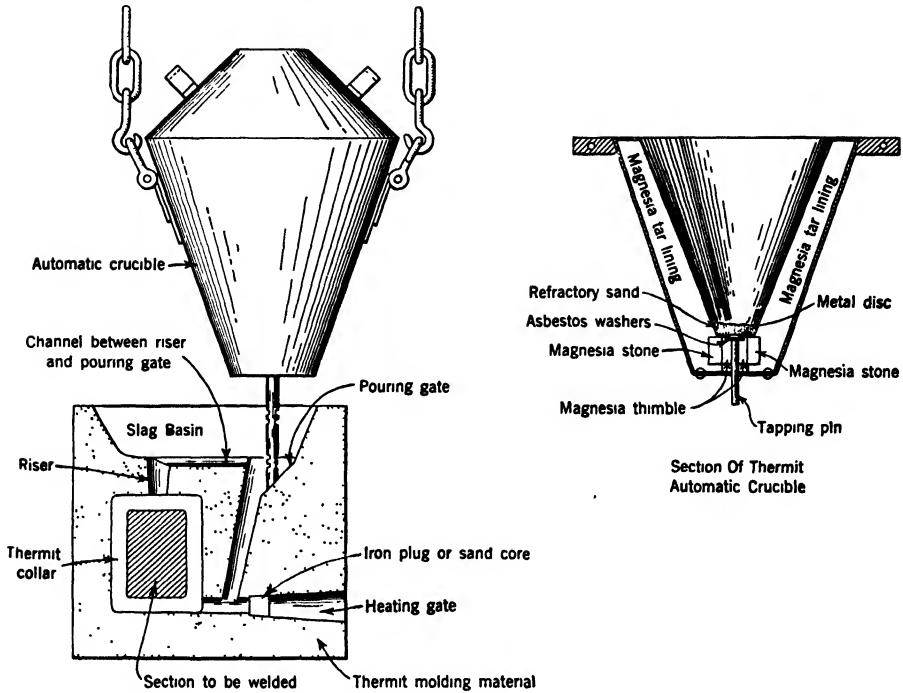


FIGURE 347. Setup used for the Thermit process. (From *American Welding Society Handbook*, 1942 ed.)

ing heavy sections of ferrous metals. Railroad and streetcar rails frequently are joined in the field by this means.

The usual Thermit mixture contains elements other than aluminum and iron oxide and hence gives a steel analyzing about 0.30% C – 0.50% Mn – 0.15% Si – 0.04% S – 0.05% P – 0.12% Al – rem. Fe, and having an average tensile strength of about 72,000 psi with an elastic limit of about 36,000 psi. It is seen readily that these properties approximate those of the best steel castings as well as those of many forgings. This is a natural result of the purity of the ingredients, and the consequent cleanliness of the resulting casting, as well as the comparatively rapid cooling caused by absorption of heat by the sections being welded. By proper use of alloying elements, in fact, tensile strengths higher than 100,000 psi can be secured, making it entirely feasible to place metal in the weld which is superior in mechanical properties to the parts being joined.<sup>19</sup>

For a time the Thermit mixture was also used for incendiary bomb charges, although magnesium-aluminum alloy powder, in a magnesium alloy casing, has largely replaced it for this purpose.

<sup>19</sup> See also Chap. 13 of Ref. 16 at the end of this chapter.



## ELECTRIC-RESISTANCE WELDING

By passing a heavy current through parts to be welded, sufficient heat can be generated internally by their electrical resistance to raise them to the welding temperature. The speed of welding then will be determined by the rate at which the required heat can be generated, always considering, of course, the additional heat which will be lost by radiation and by conduction into the electrodes and the metal surrounding the weld as well as that required in the weld zone itself.

Most simply, this heat can be expressed by the equation:

$$H = I^2RtK$$

where

- $I$  = the current passing, in amperes
- $R$  = the total resistance, in ohms
- $t$  = the time of current flow, in seconds
- $K$  = a radiation and conduction loss factor

From this equation it can be seen at once that, for otherwise constant conditions, the heat generated is directly proportional to the square of the current. Thus, doubling the current quadruples the heat. Likewise, the total heat generated is proportional to the time of current flow. However, time is only effective if the current used exceeds the minimum required to attain the welding temperature and to satisfy the existing loss factor. It can also be seen that, since an approximately constant amount of heat would be required to produce a given weld, the welding current is nearly inversely proportional to the square root of the time. Thus, if the current is doubled only about a quarter of the time should be required to make the weld. Actually, the optimum time and temperature depend on the specific application as other effects introduced by extremely high currents prevent this relationship from being applied down to very short times.

The contact resistance between the parts being welded is also significant and must be considered as part of the total resistance. The important point here, however, is uniformity and reproducibility of contact resistance on welds of the same materials rather than the actual magnitude. Surface preparation and pressure between the welding electrodes are the most common means of controlling contact resistance.

The most important of the electric-resistance welding processes, nearly all of which are carried out automatically or semiautomatically in modern industrial practice,<sup>20</sup> are illustrated in principle in Fig. 348. *Spot welding* consists, most simply, of clamping pieces of sheet metal between two copper alloy electrodes and passing an electric current sufficiently strong to

<sup>20</sup> See also Chaps. 8–12 of Ref. 16 at the end of this chapter.

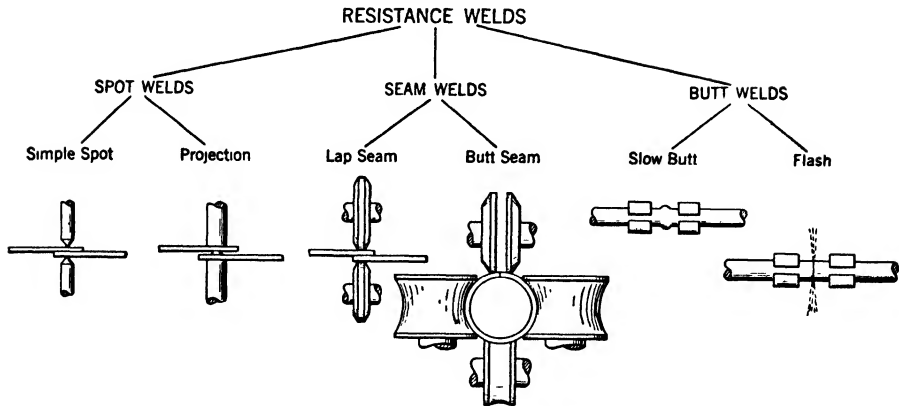


FIGURE 348. The important resistance welding processes. (From *American Welding Society Handbook*, 1938 ed.)

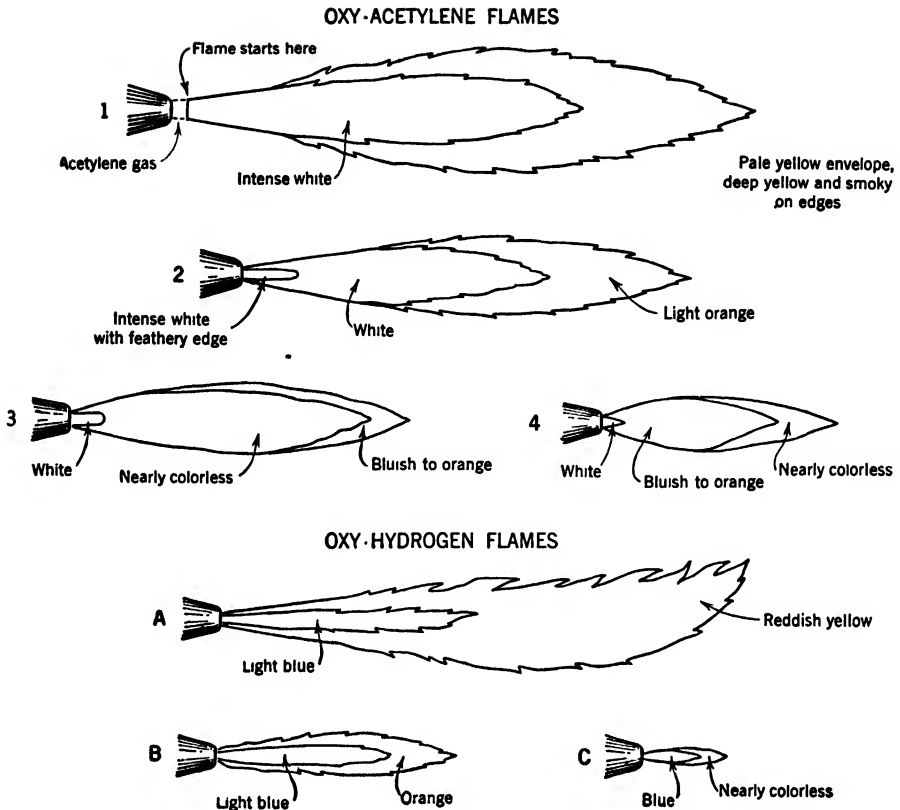
cause welding or bonding. This process gives relatively small welded areas which can be arranged according to a pattern, as in riveting, if maximum strength is desired. Sometimes *projection welding* is used in order to localize the current flow and heating during welding. Projections are formed at pre-determined points, such as on the thicker sheet of two or on the central sheet of three, and the welds are made only at these points because of the localized heating. This permits a number of welds to be made simultaneously, increases electrode life by enabling the use of larger contact areas and frequently facilitates the welding of irregularly shaped parts. *Seam welding* can be achieved either by making a series of overlapping spots or by using revolving circular wheel electrodes to give a true lap seam. In *upset butt welding* the ends of two pieces of metal are pressed together so that their juncture forms the area of highest resistance. Sufficient current is then passed to produce heating and fusion at the juncture and sufficient pressure is applied to produce the weld. *Flash welding* is carried out by passing high currents under sufficient potential to “flash” between two pieces of metal which are either in very light contact or are placed with a thin air gap between them. The flashing quickly heats the juncture to fusion temperature after which sufficient pressure is applied to effect the weld.

Resistance welding is used mainly for mass-production methods which will justify the cost of a machine especially designed to do a specific job with the greatest efficiency.

#### GAS WELDING

Metals are usually gas welded<sup>21</sup> with an *oxyacetylene flame*. The *oxyhydrogen* flame has been used also, but the temperatures that can be at-

<sup>21</sup> See also Chap. 5 of Ref. 16 at the end of this chapter.



**FIGURE 349.** Welding flames.

1. Acetylene flame: large, intensely white, smoky at outer end, obtained when first lighting torch.

2. Carbonizing flame: can be easily recognized by the feathery edge of the white cone.

3. Neutral flame: one clear, well-defined white cone surrounded by a nearly colorless flame of large volume.

4. Oxidizing flame: can be recognized by its shorter envelope of flame and the small pointed white cone.

Sketches *A*, *B*, and *C* are respectively the reducing, neutral, and oxidizing oxyhydrogen flames.

(From *Welding Aluminum and Its Alloys*, courtesy Aluminum Company of America.)

tained with it are not so high as with the oxyacetylene flame. For maximum efficiency the gases must be combined in the proper proportions and at the proper temperatures, but an experienced welder can tell this from the appearance of the flame. Some of the factors which enable him to do this to produce a reducing, neutral, or oxidizing flame are illustrated in Fig. 349. Gas welding produces a fusion weld which is equivalent to a casting in structure, since it is made by melting a filler rod and depositing it, as a

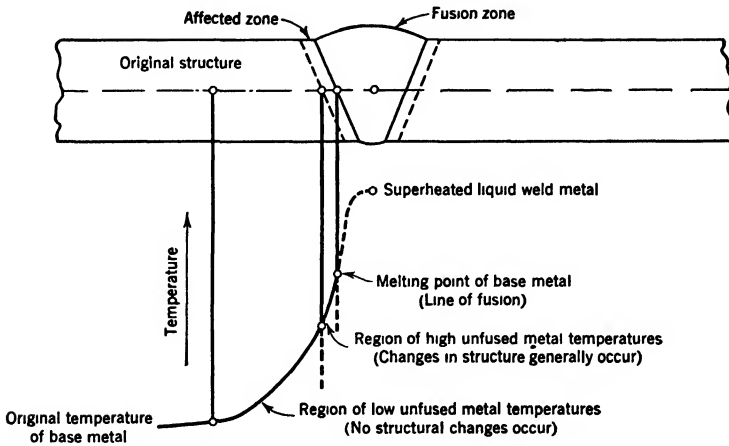


FIGURE 350. Diagram showing the maximum temperatures generally attained at and alongside a typical fusion weld. (From *American Welding Society Handbook*, 1938 ed.)

bead, on the preheated base metal. At the point of contact, both the base metal and the filler rod are molten.

The metallographic structure and properties of such a weld, for the relatively simple case of a cold-worked metal which undergoes no allotropic transformation (Fig. 351), will be those of a casting in the weld zone, and those of the annealed base metal in the preheated zone up to a point corresponding to that at which the recrystallization temperature for the base metal under the conditions of welding is reached. Beyond this, i.e., for lower temperatures, there will be no change. The maximum temperatures attained at and alongside a typical fusion weld, are illustrated diagrammatically in Fig. 350.

For the case of a weld in steel, the allotropic critical temperature will be in the neighborhood of 1330 F (725 C) depending somewhat upon the carbon and alloy content, and the regions adjacent to the fusion zone will have a coarse (austenitic) grain with accompanying poor properties. This grain size will tend to decrease as the distance from the fusion zone increases until the critical temperature zone is reached. Beyond this the base metal structure will be unchanged unless it is subject to strain recrystallization. This is indicated schematically in Fig. 351. Other metals which undergo allotropic transformations will behave similarly but will have different critical ranges.

The rate of cooling of the weld zone is extremely important because, if the critical cooling rate for the material being welded is exceeded, the joint will have martensitic properties, and be extremely hard and brittle unless it is subsequently tempered.<sup>22</sup> It is this fact which has complicated the welding

<sup>22</sup> This is discussed well by R. H. Aborn, *The Welding Journal*, October 1940.

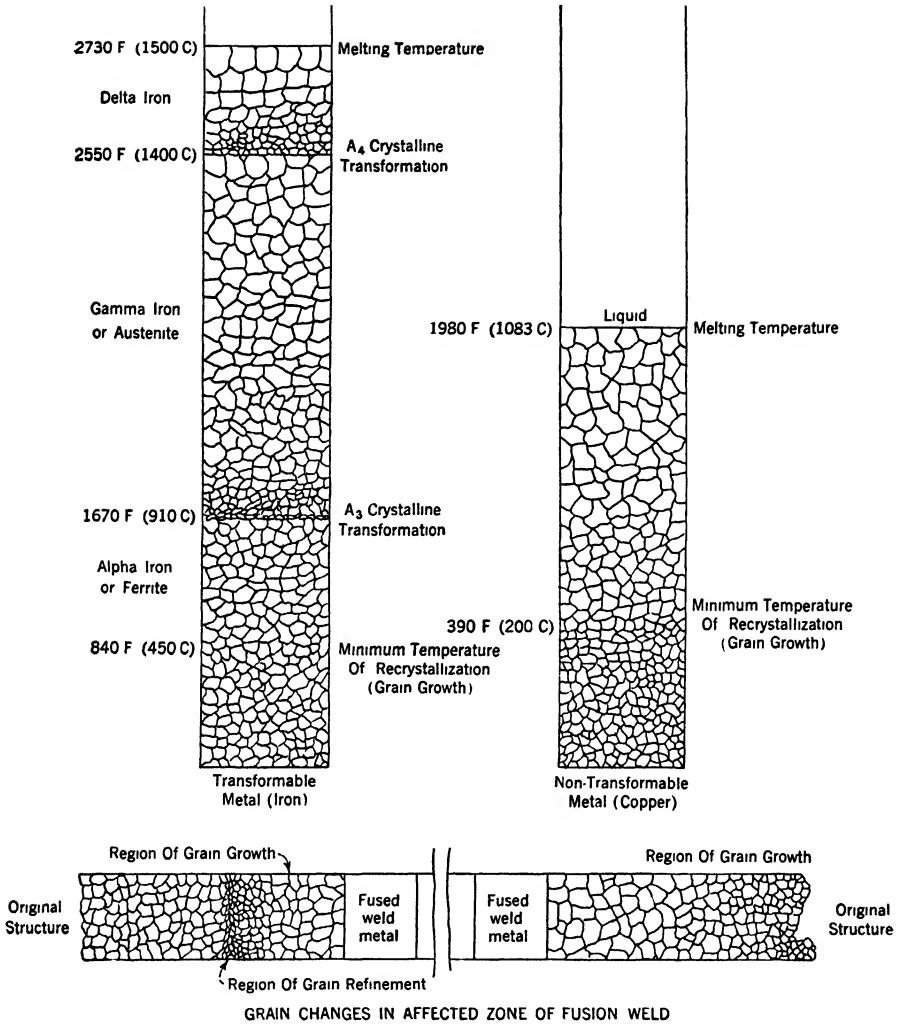


FIGURE 351. Upper, schematic changes in grain size on heating metals with (left) and without (right) allotropic transformations. Lower, schematic illustration of the manner in which these changes affect the grain size in a fusion weld. (From *American Welding Society Handbook*, 1942 ed.)

of even mild alloy steels, especially in thick sections. The cooling rate will be determined, in general, by the thickness of the section and the temperature of preheating, both of which affect the heat loss to the surroundings. Since nearly all alloying elements tend to decrease the critical cooling velocity of the austenite-pearlite inversion and since their effect is most pronounced in small amounts, the various steels which are being developed

to give the best strength properties at the lowest cost, the so-called mild alloy constructional steels, will be somewhat more difficult to weld<sup>23</sup> than plain carbon steel. It is in cases like this that metallurgical training can be of the greatest assistance to the engineer, because special techniques, based entirely upon metallurgical principles, had to be worked out and must be understood before these materials can be used satisfactorily for welded joints.

In *annealed* nonferrous metals, fusion welding probably will result in no marked change in structure or properties because, at worst, a cast structure merely will be substituted for an annealed one. However, if a *cold-worked* base metal is used, the section adjacent to the weld will, of course, be recrystallized and subjected to grain growth, as illustrated schematically in Fig. 351. This will mean that the weld zone, and a region an appreciable distance on either side of it, will have very much poorer properties than the unrecrystallized work-hardened base metal, and hence will be more susceptible than it to overload and failure.

Welding rods usually are covered with a *fluxing* or *deoxidizing* material in order to increase the soundness of the weld. It is not uncommon also for such a deoxidant to be alloyed with the electrodes used. Thus, copper alloy brazing rods

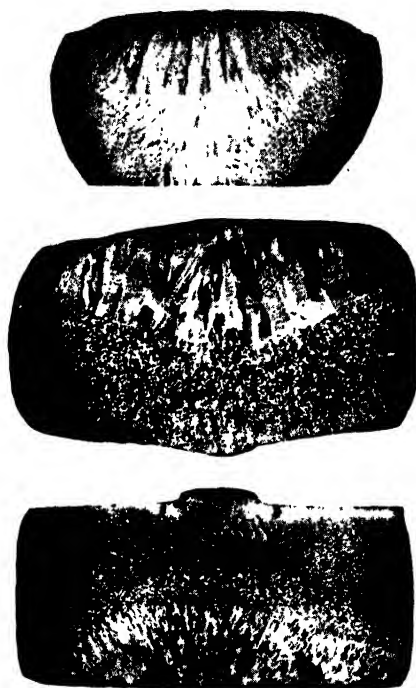


FIGURE 352. Metallographic structures of  $\frac{1}{2}$  in. silicon bronze fusion-welded plates. *Top*, weld made using high heats and not subjected to cold-working. Note the large columnar crystals which are typical of metal cast under these conditions. This structure is indicative of low strength. *Middle*, weld made using low heats and not subjected to cold-working. Note the equiaxed crystals typical of annealed wrought metal (lower portion) and the gas welded structure (upper portion) with smaller columnar crystals than above. *Bottom*, weld made using low heats and also subjected to cold-working (gas-welded portion is at bottom). Note the fine equiaxed crystals and small columnar crystals. This structure is indicative of high strength. Etched with chromic and nitric acids.  $\times 5$  originally; reduced somewhat in reproduction. (Courtesy Research Department, Chase Brass & Copper Co.)

<sup>23</sup> See also Chap. 18 of Ref. 16 at the end of this chapter.

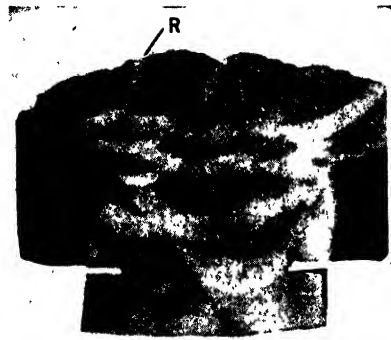


FIGURE 353. Micrograph of a 15-bead butt weld in mild steel, revealing two types of structure, the darker areas representing unrecrystallized weld metal, and the lighter areas (R) representing recrystallized weld metal.  $\times 2$  originally; reduced somewhat in reproduction. (From Bibber and Ellinger, *Welding Symposium*, The Iron & Steel Inst. (Lond.), 1935. Photomicrograph courtesy U. S. Steel Corporation Research Laboratory, Kearny, N. J.)

may contain, as alloying elements, small residual amounts of phosphorus or silicon, both of which are effective deoxidizers.

The undesirable properties of the fused zone are sometimes alleviated by *hammering* or *peening* the weld beads periodically as they are deposited, thus hot-working the metal and causing recrystallization and increased rates of diffusion and homogenization. A typical structure of a copper alloy fusion weld treated in this way is shown in Fig. 352 (*bottom*).

Similarly, recrystallization of deposited beads in fusion-welded steel can be effected by permitting each bead, after it is deposited, to cool below the critical range and transform to pearlite before the next bead is laid down. Thus, each bead will recrystallize as it is reheated

above the critical range by the subsequent welding operations. In Fig. 353, the macrographic structure of such a weld is shown. Because the various beads will have somewhat different chemical compositions and physical properties, it is comparatively simple to distinguish between them.

Gas welding requires a relatively small initial investment, and because of this and the flexibility of the equipment used it is more widely employed than any of the three preceding methods. It finds its chief application for job and utility work.

#### ATOMIC-HYDROGEN WELDING

In the atomic-hydrogen process, an arrangement similar to that shown in Fig. 354 is used. An alternating-current arc is maintained between two tungsten electrodes while, simultaneously, a stream of hydrogen gas is passed through the arc and around the electrodes. The intense heat of the arc breaks up the molecules of hydrogen into atoms which recombine outside the arc to form molecular hydrogen. The heat given off by this recombination is used to fuse the metals being welded. Although the temperature available for welding is not so great as that of the arc itself, a much larger area can be maintained at this temperature. Also, the fact that the

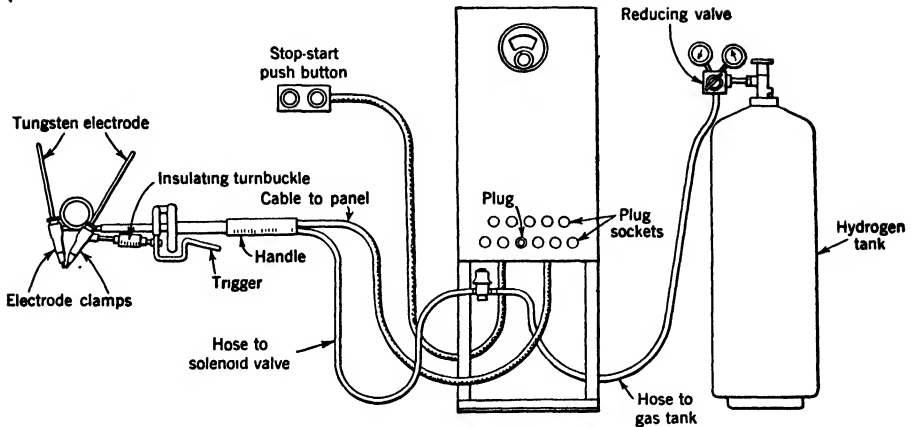


FIGURE 354. Atomic hydrogen arc-welding hand equipment. Arrangement of units. (From *American Welding Society Handbook*, 1938 ed.)

arc is surrounded completely by hydrogen enables its energy to be used more efficiently. It is to be noted that *the hydrogen does not burn*, except after recombination and movement away from the arc, so that this is not the primary source of heat, and a much higher temperature can be produced than by the oxyhydrogen flame.

The tungsten electrodes are used only as a means for establishing and maintaining the arc. They do not enter into the weld, but they are slowly evaporated by the intense heat, which has been estimated to be as high as 6000 F (3300 C). The metal or work being welded does not form part of the electric arc, so it does not need to be grounded. This process may be used, either by autogenous welding or with a filler rod, for general welding of both ferrous and nonferrous alloys or for welding thin sheet. It has not been more widely used because of its expense as compared with the usual arc-welding methods.<sup>24</sup>

### ARC WELDING

An electric arc is a sustained low-voltage electrical discharge between two terminals or electrodes. Usually, the differences in potential between the two electrodes will be of the order of 15–45 v and the current flow will vary between 20 and 800 amp. In arc welding, either alternating or direct current may be used. Although the d-c arc has been used more commonly in the past, the developments in a-c arc welding have been so marked that it is now of great industrial importance. In either case, the heat liberated by the arc, both at the terminals and in the arc stream, is used to bring the pieces being welded to the proper welding temperature so that the metals are

<sup>24</sup> See also Chap. 6 of Ref. 16 at the end of this chapter.



fused together completely, forming a single homogeneous mass after solidification.<sup>25</sup>

In arc welding, the arc is struck between the work, which must, therefore, be grounded, and an electrode held in a suitable holder (Fig. 355). The instant the arc is struck the temperature of the work at the point of welding increases to about 6000 F (3300 C), and a small pool of molten metal is formed. If additional metal is required, it is melted from a wire or rod and deposited, molten, into this pool, which is agitated by the arc and thus mixed thoroughly, so that a firm sound weld is formed when the weld is cooled. There are two general types of arc welding processes: *metal-* and *carbon-arc*.

**METAL-ARC WELDING.** In this type the arc occurs between the work and a rod of filler metal, usually 1/16–3/8 in. in diameter and 14–18 in. long. Under the action of the heat of the arc, melting occurs at both electrodes, producing a small pool of molten metal on the work and small globules of molten metal on the wire. These are carried over the arc, probably with the aid of the expansion of the gases in the metal at the tip of the arc, and deposited, in the molten state, on the work. In overhead welding, the pool must be kept small because surface tension must be sufficient to retain the molten metal in place and overcome the force of gravity. Otherwise it will drop out of the pool. This also may be true of horizontal or vertical welding depending upon the position of the weld and the direction of welding, i.e., upward or downward. Flat welding is, of course, much simpler because both surface tension and gravity act to hold the molten metal in the pool.

**CARBON-ARC WELDING.** The *double carbon arc*, which is an a-c type because it is essential that both electrodes be consumed at nearly the same rate, is relatively simple. Metal from a separate filler rod, either bare or shielded, is fed into an uninterrupted arc stream where it is melted and carried into the pool of molten metal on the work either by gravity or by surface tension.

The *single carbon arc*, on the other hand, is a d-c type with straight polarity. By making the carbon electrode the negative pole there is no carbon pickup in the weld and it is not too difficult to hold a stable arc with a constant power input. Moreover, the electrode is consumed much more slowly than it would be as the positive pole. In this type, the work forms the other pole. The carbon rods may vary in diameter, depending upon the job, between 5/32 in. and 1 in. and are usually 12 in. long. For automatic welding, intermediate diameters are used. The heat of the arc forms a small pool of molten metal on the work and extra metal is added by means of a separate filler rod.

<sup>25</sup> See also Chap. 4A of Ref. 16 at the end of this chapter.

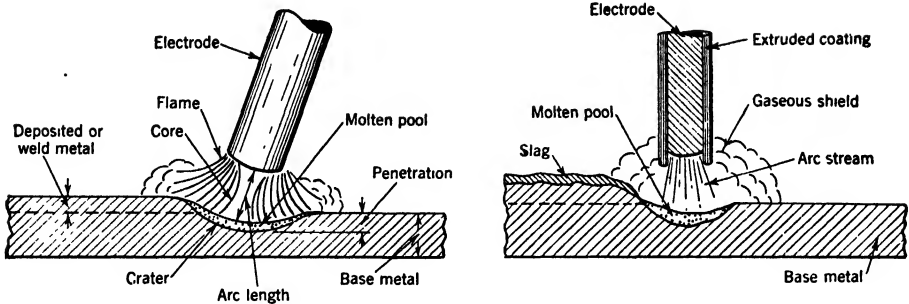


FIGURE 355. (Left) Diagrammatic sketch of an ordinary arc in process of welding showing penetration into base metal and deposited or weld metal. (From *Procedure Handbook of Arc Welding Design and Practice*, courtesy The Lincoln Electric Company, Cleveland, Ohio.)

FIGURE 356. (Right) Diagrammatic sketch showing shielding of arc and slag protection of weld metal while cooling. (From *Procedure Handbook of Arc Welding Design and Practice*, courtesy The Lincoln Electric Company, Cleveland, Ohio.)

Carbon-arc welding is primarily a puddling process and is not too well adapted to vertical or overhead welding for this reason. It can, however, be used for these positions provided the molten pool is kept small enough for surface tension to overcome the action of gravity on the molten metal. The process is most widely used for automatic or specialized operations, and for repairing steel castings. There is a marked tendency for the arc to be unstable and to wander because of its very nature and the effects of the magnetic fields set up by the welding current and the distribution of magnetic material in the piece being welded. This has been corrected, and the arc stream focused and concentrated just beneath the carbon, by placing a separate magnetic field in the proper position with reference to the arc.<sup>26</sup> These separate fields are generally built into or around the welding boot through which the carbon electrode feeds.

#### THE SHIELDED ARC

Because of the affinity of molten steel for oxygen and nitrogen and the tendency of the solid steel to be weakened and embrittled by the oxides or nitrides which are formed on solidification, it is desirable to keep these gases away from the molten metal. Similar protection is advisable in welding most nonferrous metals if sound welds are desired. Since air contains large amounts of both oxygen and nitrogen, this necessitates the use of a gas shield over the arc, as shown in Fig. 356, preferably using an inert gas that will not combine with or dissolve markedly in the molten metal.

<sup>26</sup> See also Chap. 4D of Ref. 16 at the end of this chapter.

Specially coated electrodes, whose coatings give off large quantities of gas when heated and are consumed at a slower rate than the electrode metal, are used for this purpose in manual welding. The rod coatings also affect the arc stability and the contour of the bead. In addition, the action of the arc on the electrodes forms a protective slag coating on the surface of the molten metal. This slag acts as a scavenger as well as slowing down the rates of solidification and cooling of the weld metal. Welds made with a shielded arc, because of their freedom from oxide and nitride inclusions, will have tensile strengths 20–50% higher and ductilities 100–200% higher than those deposited by the ordinary arc processes.<sup>27</sup>

#### AUTOMATIC ARC WELDING

The success of arc welding depends on maintaining practically a constant arc length. This also can be done automatically by moving the rod, usually on the end of a large coil, toward the work at a rate which is just sufficient to compensate for the section of it that melts away. This automatic control most frequently is achieved by using the voltage across the arc, dependent as it is on the arc length, to control the speed of a d-c motor which operates the feeds. Two general methods of automatic arc welding are used depending upon the amount of shielding that is desired.<sup>28</sup>

The method most commonly employed uses either a bare rod or else a rod coated lightly enough that the insulating qualities of the coating will not interfere greatly with the electrical contact with the rod. Naturally the amount of shielding from this thin coating is not great although the coating also assists in stabilizing the arc and controlling the melting rate with some types of automatic electrodes. Welds produced by using these bare or lightly coated rods have only moderate tensile strength and low ductility, however.

Shielded arc welding also can be done successfully by any of a variety of automatic methods, the chief drawbacks being the insulating qualities of the flux coating and its relative brittleness which make coiling very difficult except in larger sizes of rod. However, with this limitation that straight lengths of rod or large diameter reels must be used, satisfactory contact can be maintained with the rod by (a) having projections extend through the coating, (b) scraping the flux off in small spots periodically, or (c) coating the bare rod with a flux-impregnated tape, just before it is fed into the arc. Several other methods also are used with success.

<sup>27</sup> See, for example, Chap. 4E of Ref. 16 at the end of this chapter.

<sup>28</sup> See also Chaps. 4C and 4D in Ref. 16 at the end of this chapter.

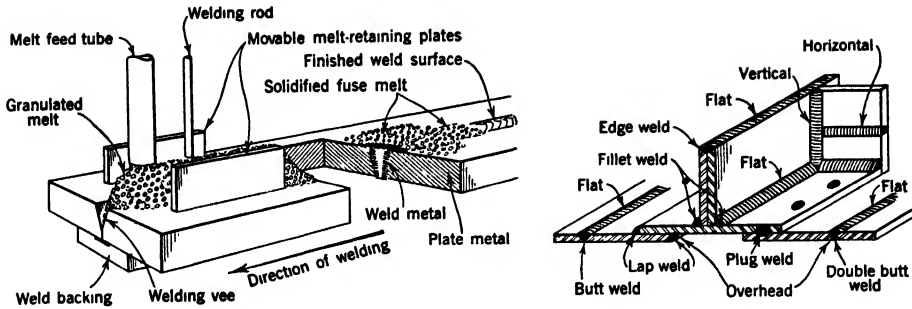


FIGURE 357. (Left) Schematic illustration of a submerged melt process for automatic arc welding. (From *American Welding Society Handbook*, 1942 ed.)

FIGURE 358. (Right) Examples of welds and locations. (From *Procedure Handbook of Arc Welding Design and Practice*, courtesy The Lincoln Electric Company, Cleveland, Ohio.)

#### SUBMERGED MELT WELDING

Another method which can be adapted to a wide variety of materials and applications is *submerged melt welding*,<sup>29</sup> a well-known example of which is known as the *Unionmelt process* (Fig. 357). Its use, however, is restricted to welding on an approximately horizontal plane. In this process alternating or direct current passes from the welding rod to the work through a high-resistance granulated medium known as *Unionmelt*. This material is laid down automatically in advance along the seam to be welded and surrounds the end of the welding rod completely, thereby protecting the entire welding operation which takes place without visible external signs. Voltages of the order of 20–55 are used, and the current may approach 4000 amp depending on the type of equipment. Intense heats thus are generated very rapidly and protected against radiation losses by the Unionmelt blanket. Metal thicknesses as great as  $2\frac{1}{2}$ –3 in. can be welded in one pass and a 5-in. plate could be welded by one pass along each side. However, by far the greatest field of usefulness for this process lies in being able to weld completely thicknesses of steel between  $\frac{3}{8}$  in. and about 1 in. in a single pass or two passes at the most. The molten portion of the Unionmelt layer floats on the liquid weld metal protecting it from the atmosphere, in addition to fluxing some of its impurities. These combined actions tend to result in a very dense deposit.

#### TYPES OF JOINTS THAT CAN BE WELDED

Figure 358 indicates examples of the welds used commercially. There are four general locations usually considered, all of which are illustrated:

<sup>29</sup> See also Chap. 7 in Ref. 16 at the end of this chapter.

1. A *flat* weld, made from the top side of the plane
2. A *vertical* weld
3. An *overhead* weld, made from the under side of the plane
4. A *horizontal* weld

In addition, there are five general classifications of welds, as *butt*, *fillet*, *lap*, *edge*, and *plug* welds.

#### SUITABILITY OF WELDS

It must be remembered always that fusion welds are similar in structure to castings, and hence are susceptible to all the troubles to which castings are susceptible, such as unsoundness, inclusions, segregation, and internal strains. All of these can be avoided by designing the weld properly, using an experienced welder, stress relieving after welding, and by carefully testing the finished weld to ensure soundness. The greater the possibility of serious damage or loss of life through failure, the more carefully should the weld be made and tested.

Experienced welders usually are certified for welding in the various locations listed above; and, as a general rule for engineering structures, a given type of weld should be made only by experienced welders who have been properly certified for that type of work. *Welding is a much more complex operation than is usually realized, and it can be done successfully only by an experienced welder.*

In many cases, however, engineering skills can overcome welding difficulties. For example, the troublesome overhead and vertical welds can sometimes be largely eliminated by welding the parts in a flat position before assembly. By using this method in shipbuilding only a few assembly welds need be made in awkward positions.<sup>30</sup>

#### STRESS RELIEVAL OF WELDS

Stress relief of steel welds should be carried out by heating either the complete welded part as a unit, or complete sections of the part, at least to 1100 F (590 C) and preferably to 1200 F (650 C) or higher if this can be done without distortion.<sup>31</sup> The sections should be held at temperature at least 1 hour for each inch of thickness of the thickest section, and cooled at a rate which will largely be determined by the composition of the metal, but which should always be slow. A commercial furnace used to stress-relieve welded pressure vessels, and large enough to receive an entire flat-

<sup>30</sup> See, for example, Chap. 40A, of Ref. 16 at the end of this chapter.

<sup>31</sup> See also Chap. 32B, of Ref. 16 at the end of this chapter.



FIGURE 359. Large stress-relieving furnace, in the plant of the Sun Shipbuilding & Dry Dock Co., Chester, Pa. Used for stress-relieving welded pressure vessels and other welded structural work and for annealing large steel castings. Inside length is 80 ft and inside width 18 ft. (Courtesy Sun Shipbuilding & Dry Dock Co.)

car, is shown in Fig. 359 to give a better idea of the magnitude of some of these operations.

#### TESTING WELDS

In addition to the usual destructive mechanical tests such as tensile strength and elongation, impact, slow bending, fatigue, and fracture, which cannot be applied to the finished weld itself for obvious reasons, the three general methods of nondestructive testing which have already been described are used.<sup>32</sup> Large welds usually are tested by radiographic or gamma-ray techniques and small welds, or those difficult to reach by the usual X-ray equipment, are tested by the Magnaflux or fluorescent penetrant methods. The Magnaflux method is suitable for thin sheets, in particular. Pressure vessels, which come under A.S.M.E. Boiler Code Specification

<sup>32</sup> See also the section on *Testing*, in Ref. 16 at the end of this chapter.

U-68, are required to be tested completely by X-ray or gamma-ray radiographic methods, for all longitudinal and circumferential welded joints throughout their entire length.

### *Methods for Removing Metal*

Most of the finishing costs on parts fabricated from metal are directly chargeable to *machining* operations in some form or another. Hence, any methods which can improve these operations are bound to result in substantial savings. Modern industrial processes also are using to advantage other methods for removing metal, such as *flame cutting* and *arc cutting*, especially when subsequent treatment would render ineffective the usual machining operations.

#### MACHINABILITY

*Machinability*<sup>33</sup> may be defined as the relative ease of cutting, where *cutting* may mean turning, shaping, planing, drilling, reaming, tapping, milling, sawing, broaching, or any of the many other similar operations. However, the exact significance of this term must be interpreted with regard to tool life, cutting speed, energy or power requirements, the surface finish of the cut, and the accuracy of the cut. It is realized by all who have considered the problem that any evaluation of machinability must include an extremely complex combination of the factors: *machining process*, *type of tool* and *tool material*, *cutting fluid*, and *cutting conditions*, as well as the metal being cut. Changing any of these factors can change the relative machinability to a large extent. Only a few of the factors affecting the metal being cut will be discussed here briefly.

#### TYPES OF CHIPS

There are three fundamental types of chips secured in machining operations,<sup>34</sup> almost regardless of the metal being machined. These are illustrated in Fig. 360.

1. The *discontinuous chip*. This may be outwardly continuous but is structurally discontinuous with definite shearing ruptures across the chip approximately perpendicular to the tool face and manifested by a ragged saw-toothed appearance on the inner edge. In materials of low ductility, these chips may break up entirely.

<sup>33</sup> For a complete discussion see Ref. 17 at the end of this chapter.

<sup>34</sup> See Hans Ernst in Ref. 17 at the end of this chapter, pp. 1-34.

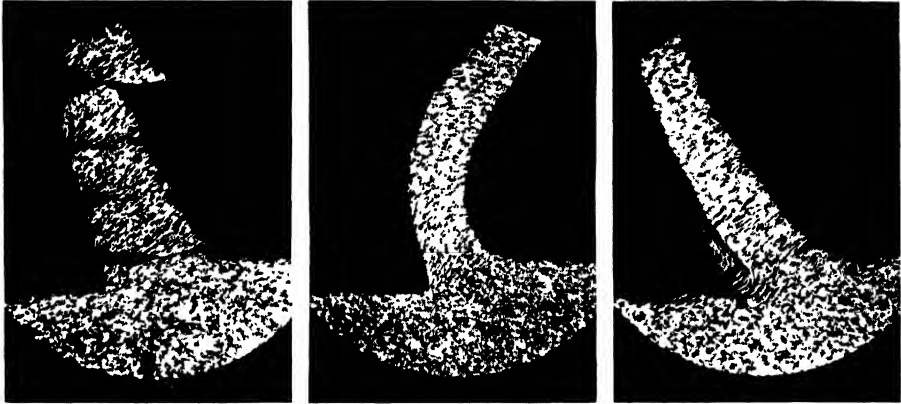


FIGURE 360. The three basic types of machining chips.

a. (Left) Type 1: discontinuous.

b. (Center) Type 2: continuous, without built-up edge.

c. (Right) Type 3: continuous, with built-up edge.

(Courtesy The Cincinnati Milling Machine Co., Cincinnati, Ohio.)

2. The *continuous chip without a built-up edge*. This type of chip is relatively smooth on both sides, with little or no tendency for transverse rupture.
3. The *continuous chip with a built-up edge* adjacent to the tool face. In this type, there is a definite tendency for the chip to adhere strongly to the tool face, thus interposing between the tool and the flowing chip a relatively stationary mass of material, generally termed *the built-up edge*. At intervals, fragments of the built-up edge shear off and escape with both the chip and workpiece, thus leaving the surfaces covered with small irregularly spaced projections. The finish obtained with this type of chip is therefore much poorer than that obtained with the type 2 chip.

The *discontinuous* or segmental type of chip tends to result from machining brittle materials, from lower cutting speeds, or from heavier feeds. Materials giving this type of chip suffer very little plastic deformation and comparatively little heat is transmitted to the tool. The metal ahead of the tool is compressed by it until rupture occurs. The entire chip element then escapes by passing up the face of the tool. Although the machinability of materials giving this type of chip under normal cutting conditions generally is considered to be good, because the finish of the work is good when the pitch of the segments is small, there is a tendency for chattering to occur. This type of chip is the one most easily disposed of and hence materials which give it are desirable for automatic screw machine work.

With ductile materials the *continuous chip without a built-up edge* gives



the best surface finish and hence, for the majority of machining operations, is often considered to be the "ideal" chip. This type chip is produced in the ductile materials by light feeds, high cutting speeds, and conditions which tend to decrease the coefficient of friction between the work and the tool face. Some of these factors are keen edge, proper tool material (this is one reason for the excellent results secured with the various carbide tools), highly polished tool face, large rake angle, and proper temperature at tool point. The metal is compressed ahead of the tool tip as before, but, because of its ductility, it is regularly deformed and passed off up the tool face. Because of the deformation, considerable heat is developed in the chip, part of which is transmitted to the tool. This is one reason why tool material selection is important.

Ductile materials which adhere to the tool face, or which are machined under conditions which tend to promote such adherence, tend to give a *continuous chip with a built-up edge*. Work which machines with this type of chip will appear to be "rough" because of the presence of the small fragments of built-up edge. Since the building up and breaking down of the built-up edge takes place very rapidly, the machined surface will be covered with large numbers of these fragments. It is quite probable, however, that the chip formation may be modified so as to approach the much more desirable second type largely by proper control of the cutting conditions. This is one reason why it is always advisable to consult the producer of any material before getting too much involved in the problems of machinability.

#### STRUCTURAL FACTORS AFFECTING MACHINABILITY

Hardness is not too important a factor in machinability as long as it is not accompanied by ductility. A maximum of 300 Brinell generally is set as the limit for commercial machining, because materials much harder than this are apt to result in too great a tool wear.

In steels, in particular, there is some relationship between machinability and Brinell hardness.<sup>35</sup> This is not surprising because, generally, in these alloys the ductility decreases as the hardness increases. However, an increased hardness results in an increased machinability only within the limit of about 300 Brinell mentioned above, hardnesses greater than this tending to cause marked tool failure through wear and breakage. Actually, of course, the basic factors influencing machinability are chemical composition, mechanical and thermal treatment, and metallographic structure, and it is the combined effect of these factors on hardness which results in the empirical relationship between it and machinability.

<sup>35</sup> See, for example, H. B. Knowlton in Ref. 17 at the end of this chapter.



a



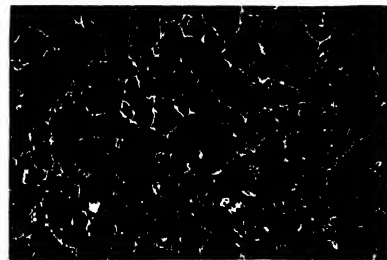
b



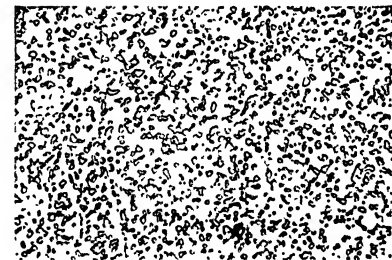
c



d



e



f

FIGURE 361. Metallographic structures of various alloys which will have comparatively poor (*left*) and comparatively good (*right*) machinabilities.

*Aluminum alloys:*

a. 3S-O. Etched with  $\frac{1}{2}\%$  HF.  $\times 100$ .

b. 11S-T3. Etched with Keller's reagent.  $\times 100$ .

*Copper alloys:*

c. Annealed copper. Etched with  $\text{NH}_4\text{OH} + \text{H}_2\text{O}_2$ .  $\times 75$ .

d. Leaded high brass (65% Cu - 0.9% Pb - rem. Zn). Etched with  $\text{NH}_4\text{OH} + \text{H}_2\text{O}_2$ .  $\times 75$ .

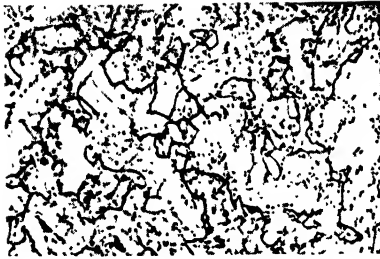
*Wrought carbon steels:*

e. 1.24% carbon steel, normalized. Etched with nital.  $\times 100$ .

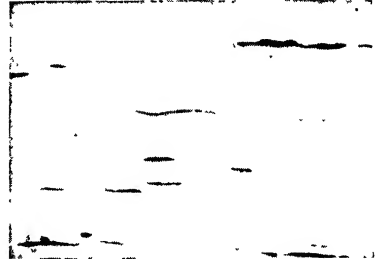
f. 1.25% carbon steel, spheroidized. Etched with nital.  $\times 500$ .

Cold-working frequently is used to harden the material, and embrittle it to some extent, thereby improving its machinability. However these conditions also tend to result in comparatively high internal stresses; and, unless these are relieved by a preliminary stress-relief anneal, they are liable to cause distortion during machining.

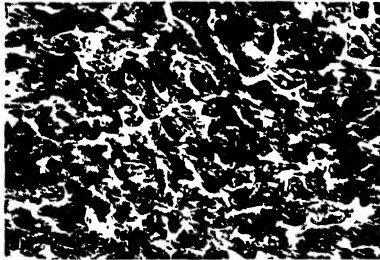
For finish cuts some ductility seems to be desirable, as good surface finish



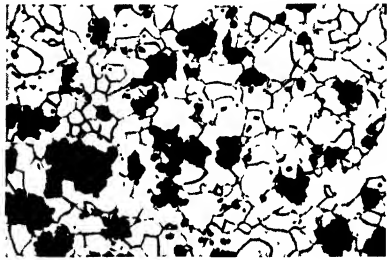
g



h



i



j

FIGURE 361 (continued). Wrought stainless steels:

g. Annealed stainless iron (12% Cr - 0.12% C - rem. Fe). Etched with hydrochloric-picric acid reagent.  $\times 500$ .

h. Hot-rolled free-cutting stainless iron (12% Cr - 0.10% C - 0.30% S - rem. Fe). Unetched.  $\times 250$ .

Cast irons:

i. White cast iron. Etched with nital.  $\times 50$ .

j. Malleable cast iron. Etched with nital.  $\times 100$ .

apparently is related to a burnishing action at the surface, and ductile metals are somewhat superior in this respect.

#### MACHINABILITY OF ALLOYS

To assist in breaking up chips, alloying elements which will appear as small particles of an insoluble second phase often are added. If these are of the right constitution, they also serve the added function of increasing tool life. In addition, the use of the proper heat-treatment often will effect appreciable improvement in machinability. In Fig. 361 are shown several structures which are considered to give "good" and "poor" machinability for that type of material, and in Fig. 362 an approximate table of relative machinabilities is given.

In steels, a fine-grained structure (A.S.T.M. 5-8) generally is preferred for finish cuts because of its higher ductility, whereas a coarse-grained structure (A.S.T.M. 1-5) gives a better roughing cut. In low- and medium-carbon steels, a lamellar pearlite structure usually is found to have a good machinability, and cold-drawn stock is preferred. In high-carbon steels, a completely spheroidized structure machines best. In the higher alloyed

FERROUS		NONFERROUS
<b>GROUP I</b> Excellent to Very Good		
		Magnesium alloys
<b>GROUP II</b> Very Good to Good		
		Free-turning aluminum Free-cutting and leaded brasses Free-cutting copper (Pb-, Se-, or Te-) Copper lead alloys Leaded cast brasses and bronzes Lead-base babbitt
<b>GROUP III</b> Good to Fair		
Leaded screw stock Low-carbon screw stock Malleable cast iron (Ferritic) Graphitic steels Free-machining high strength carburizing stock Free-machining high-strength heat-treating stock Low-carbon carburizing stock Malleable cast iron (Pearlitic) Gray cast iron		Aluminum-magnesium alloys Wrought aluminum-copper alloys Alpha beta brass (Muntz and naval types) Leaded wrought bronze and nickel silver Nonleaded yellow brass Tin babbitt Zinc alloys
<b>GROUP IV</b> Fair to Poor		
Cast steel Free-machining 12% and 17% chromium stainless steels Medium-carbon heat-treating steels Low-alloy S A E carburizing steels Low-alloy S A E heat-treating steels Ingot iron Wrought iron Free-machining 18 8 stainless steel		Copper and chromium-copper Low-zinc red brasses Silicon and phosphor bronze Aluminum-silicon and aluminum casting alloys Wrought aluminum Cupronickel and nickel silver Beryllium bronze Manganese- and wrought aluminum bronze
<b>GROUP V</b> Poor to Very Poor		
Austenitic cast iron ( <i>Ni-resist</i> type) 12% and 17% chromium stainless steels Carbon tool steels Low-alloy tool steels High-alloy tool steels (high-speed and high carbon-high chromium) Wrought heat-resisting alloys		<i>R Monel</i> Cast aluminum bronze <i>Hastelloy</i> <i>A Nickel</i> <i>Monel</i> <i>H- and S Monel</i> Wrought heat-resisting alloys
<b>GROUP VI</b> Practically Non machinable (Grind only)		
Chilled cast irons <i>Duriron</i> Heat-resisting castings (such as 15 35 and 29 9 types)		<i>Stellite</i> Sintered carbides

FIGURE 362. Relative machinabilities of some metals and alloys. The differences between alloys in the same group are generally much less than those between alloys in different groups. The mechanical and heat-treatments given the material can affect its machinability drastically. This table was drawn up on the assumption that the optimum condition obtained in each case.

steels annealing or normalizing tends to give a more machinable structure, although austenitic structures, such as those of the stainless steels, tend to be difficult to machine. In these the chips break off readily enough but tend to build up on the tool face. Alloying elements added to improve machinability are sulfur, lead, phosphorus, and, in some alloys, selenium and tellurium. Graphitic structures, in which the graphite appears either as

flakes or nodules, also machine very well, although the nature of the metallic matrix will be very important in determining tool wear.

Nickel-base alloys are, in general, fairly difficult to machine. Somewhat higher amounts of sulfur than are generally present as an impurity are often added to improve their machinability to a certain extent, and the use of sulfur-bearing cutting fluids assists materially.

Copper-base alloys tend to give continuous chips if single-phase, and discontinuous chips if they have two-phase duplex structures. The free machining alloys, which give fine broken chips, generally contain added lead, selenium, or tellurium.

Bismuth and lead are added to aluminum alloys to increase their machinability, although some of the age-hardening alloys give good results without special additions, because of the nature of the fine precipitate formed. The presence of free silicon in aluminum alloys will usually increase tool wear appreciably.

Magnesium alloys have, in general, excellent inherent machining properties, and need no improvement. However, certain simple precautions must be taken to avoid the possibility of fire because of the inflammability of the fine chips.

Lead, tin, and zinc, in general, are soft enough that no trouble is encountered in machining them if reasonable care is taken. However, their inherent softness and ductility render them far from free machining.

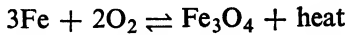
For each metal and alloy there is an optimum tool shape, size, and method of grinding. Proper consideration of speeds and lubrication is also important if the best results are to be secured. The manufacturers and producers of the various metals and alloys have devoted considerable time and study to securing information of this sort, and they should be consulted whenever the use of a new material is contemplated.

#### FLAME CUTTING

Any metal or alloy whose oxidation liberates a large enough amount of heat, and whose thermal conductivity is low enough to permit this heat to remain concentrated in a relatively small area, may be *flame* or *oxygen cut*.<sup>36</sup> The ferrous materials are particularly well adapted for this purpose, and flame-cutting is now widely used with them, especially when the cut pieces are subsequently to be assembled by welding. Under such conditions, the added cost of machined surfaces is often a needless expenditure. The cutting process is primarily a chemical one, based on the affinity of the metals being cut for oxygen when they are heated to the proper "kindling" tem-

<sup>36</sup> See also Chap. 16 of Ref. 16 at the end of this chapter.

perature. This is, for ferrous materials, of the order of 1400–1600 F (760–870 C), a bright red color in daylight. The reaction probably corresponds to:



Only the metal within the direct path of the oxygen jet is affected, and several thicknesses can be cut or trimmed simultaneously. In linear cutting or severing, a narrow *race* or *kerf* is formed having uniformly smooth and parallel walls. Thicknesses of the order of 24 in. for manual cuts and 33 in. for machine cuts, which are uneconomical to cut by any of the mechanical machining methods, can be flame cut with practically the same economy and almost the same speed as any of the lighter gauges. For complicated shapes pantographic arrangements are used, as illustrated in Fig. 363. Thicknesses as great as 12 in. of steel can be cut at a speed approximating 2 lin in. per min.

Acetylene is the most widely used fuel gas. After preheating with an oxy-acetylene flame, either an oxidizing flame or pure oxygen is used for cutting, the energy produced by oxidation of the iron being sufficient to keep the process going.

The same principle is employed in the process of *flame-machining*, used primarily to surface ferrous metals in much the same way as a planer or milling machine is used. Here, however, the cut does not penetrate through the work.

Under proper conditions and using an especially designed torch, gas-cutting can be carried out under water by an expert diver experienced in its use. However, for depths greater than 35 ft hydrogen must be used instead of acetylene.<sup>37</sup>

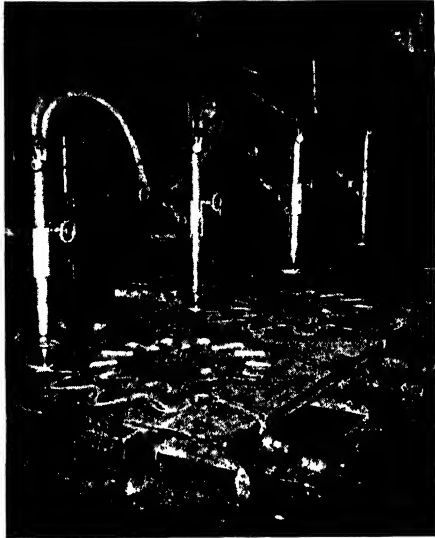
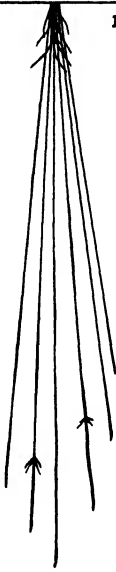
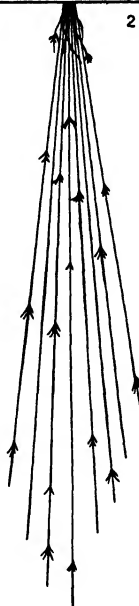






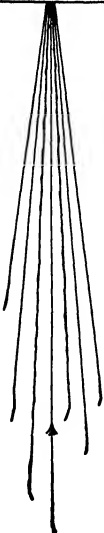

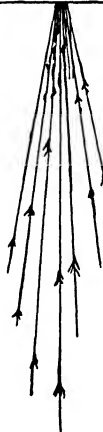

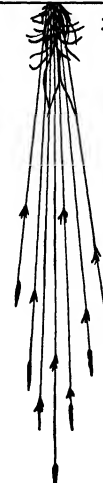



FIGURE 363. Modern commercial flame-cutting machine simultaneously trimming four machine-shapes out of a steel plate. (Courtesy The Linde Air Products Company.)

#### ELECTRIC-ARC CUTTING

Both the metal- and carbon-arc processes can be used for cutting by applying the heat energy of the electric arc to melt the metal along the de-

<sup>37</sup> See Chap. 16D of Ref. 16 at the end of this chapter.

Wrought Iron	Machine Steel	Carbon Tool Steel	Gray Cast Iron	White Cast Iron
 <p>1</p>	 <p>2</p>	 <p>3</p>	 <p>4</p>	 <p>5</p>
				<p>Annealed Malleable Iron</p>
				 <p>6</p>

High Speed Steel	Manganese Steel	Stainless Steel	Tungsten-Chromium Die Steel	Nitrided Nitralloy
 <p>7</p>	 <p>8</p>	 <p>9</p>	 <p>10</p>	 <p>11</p>
		<p>Stellite</p>	<p>Cemented Tungsten Carbide</p>	<p>Nickel</p>
		 <p>12</p>	 <p>13</p>	 <p>14</p>

sired line of cut. However, since this method has neither the accuracy nor the flexibility of flame-cutting, it is not used so widely and is of value chiefly in cutting risers from difficultly machinable castings, cutting rivets, piercing holes, etc.<sup>38</sup>

### GRINDING

Grinding is a process of wearing away by using abrasive materials imbedded in suitable carriers. The characteristics of the grinding wheel depend upon the type of abrasive and its coarseness and degree of hardness, and upon the process by which the wheel is bonded.

Aluminum oxide, and silicon and boron carbides are the principal abrasives used. As a rule, grinding is used only (a) for surfacing materials difficult to machine by other methods, and (b) for cutting with very thin wheels.

Depending upon the conditions under which it is carried out, grinding may either cut metal from the surface or else distort the surface layers severely, forming a layer of flowed metal whose properties are not the same as those of the original material.

### THE SPARK TEST

An experienced operator can classify steels, according to their chemical analysis, by visual examination of the sparks thrown off when the steel is held against a high-speed grinding wheel. This is the spark test. It is not intended to substitute for chemical analysis but only to assist in classification and separation of metals and alloys in the plant or scrap yards. The differences in sparks for several different types of steels are illustrated in Fig. 364.

#### *For Further Study Refer to*

1. *Metals Handbook*: American Society for Metals, Cleveland, Ohio, 1939 (usually published triennially). A new edition will appear in 1948.

<sup>38</sup> For a more thorough discussion see C. H. Jennings in Chap. 17 of Ref. 16 at the end of this chapter.

---

FIGURE 364. Spark test for metals. (From *Grits and Grinds*, courtesy Norton Company, Worcester, Mass.)

Note the simple forking effect in the wrought iron and the almost complete absence of any secondary bursts because of the low carbon content. As the carbon increases in a plain carbon steel the number and intensity of the secondary bursts increase. The appearance of the high-speed steel spark is characteristically different because of its red color. In any comparison test of this sort the use of standard samples is recommended strongly as a check.



2. *Steel Castings Handbook*: Steel Founders' Society of America, Cleveland, Ohio, 1941.
3. *Cast Metals Handbook*, 2nd ed.: American Foundrymen's Association, Chicago, Ill., 1939.
4. *Foundry Work*, by W. C. Stimpson and B. L. Gray: American Technical Society, Chicago, Ill., 1939.
5. *Die Castings*, by Herbert Chase: John Wiley & Sons, Inc., New York, 1934.
6. *Die Castings*, by A. Street: Emmott & Co., Ltd., London, 1939.
7. *Symposium on the Plastic Working of Metals*: Transactions American Society for Metals, Cleveland, Ohio, December 1936, January 1937.
8. *The Making, Shaping, and Treating of Steel*, 5th ed., by J. M. Camp and C. B. Francis: Carnegie-Illinois Steel Corp., Pittsburgh, Pa., 1940.
9. *Metal Processing*, by O. W. Boston: John Wiley & Sons, Inc., New York, 1941.
10. *The Working, Heat Treating, and Welding of Steel*, 2d ed., by H. L. Campbell: John Wiley & Sons, Inc., New York, 1940.
11. *The Working and Heat Treating of Steel*, by R. H. Harcourt: Stanford University Press, Stanford University, California, 1938.
12. *Forging Practice*, by C. G. Johnson: American Technical Society, Chicago, Ill., 1938.
13. *Forging Handbook*, by W. Naujoks and D. C. Fabel. American Society for Metals, Cleveland, Ohio, 1939.
14. *Metallurgy of Deep Drawing and Pressing*, by J. D. Jevons: John Wiley & Sons, Inc., New York, 1940.
15. *Welding Metallurgy*, by O. H. Henry and G. E. Claussen: American Welding Society, New York, 1940.
16. *Welding Handbook*, 1942 ed.: American Welding Society, New York, 1942.
17. *Machining of Metals*: American Society for Metals, Cleveland, Ohio, 1938.
18. *Engineering Materials and Processes*, by W. H. Clapp and D. S. Clark: International Textbook Co., Scranton, Pa., 1938.
19. *Metal Progress*: American Society for Metals, Cleveland, Ohio (published monthly).
20. *Transactions American Society for Metals*: A.S.M., Cleveland, Ohio (published annually).
21. *Ferrous Metallurgy*, by E. J. Teichert: McGraw-Hill Book Company, Inc., New York, 1944.

22. *Symposium on Powder Metallurgy*: American Society for Testing Materials, Philadelphia, Pa., 1943.
23. *Symposium on Production and Design Limitations and Possibilities for Powder Metallurgy Parts*: Metals Technology, T.P. 1788, January, 1945.

## Corrosion, Its Effects and Control

### IMPORTANCE OF CORROSION

FOR NEARLY ALL METALS THE COMBINED STATE IS THE NATURAL one and, therefore, the one to which the metals tend, in time, to return when they are used in engineering structures. It is impossible to stop completely this process of chemical decline, called *corrosion*, although, by employing suitable protective measures and by proper selection of the alloys used, the rate at which it occurs can be decreased, often markedly. Corrosion is of industrial importance for two fundamental reasons. The first, and most obvious one, is that it causes structures to become unsafe or useless in a much shorter time, in many cases, than they would become obsolete, thus increasing depreciation charges and operating deficits. The second is that it requires that parts be designed much heavier and thicker than otherwise would be necessary. Corrosion is one of the principal reasons why comparatively large factors of safety often must be used. Thus, by increasing the dead load in order to compensate for the effects of corrosion the live or pay load on a structure is decreased. The uncertainty arising from the possibility of sudden failure resulting from corrosion, causing loss of life or property damage, is also a factor which cannot be overlooked.

### CONTROL OF CORROSION

There are various theories of corrosion. However, it is more important for the engineer to be conversant with the several factors which are known to determine the rate of corrosion than it is for him to understand the theoretical explanations that have been suggested for it. According to several authorities,<sup>1</sup> the corroding effect of any medium is determined by six factors which are all susceptible to measurement and observation and are thus useful for purposes of diagnosis. These are:

<sup>1</sup> See, for a complete discussion, R. J. McKay and R. Worthington, Ref. 1 at the end of this chapter.

- |                              |                                  |
|------------------------------|----------------------------------|
| 1. Acidity                   | 4. Film formation                |
| 2. Oxidizing characteristics | 5. Rate of movement or agitation |
| 3. Electrolysis              | 6. Temperature                   |

The majority of the corrosion encountered in engineering applications takes place in atmospheric or aqueous media. The above factors, therefore, apply primarily to these conditions. However, if used intelligently, they can aid materially in rationalizing the more severe types of chemical corrosion, both liquid and gaseous.

The difference between atmospheric and aqueous corrosion is largely one of degree since water is the important agent in either case. Dry atmospheres at normal temperatures have very little corroding effect in themselves and since their electrical conductivity is very low the possibility of galvanic attack is kept to a minimum. This obvious fact, however, seems to be overlooked frequently as great pains often are taken to avoid the use of dissimilar metals under such conditions even though the danger of corrosion is then very small indeed. As the amount of moisture in the atmosphere increases its corroding tendency rapidly approaches that of an aqueous solution as would be expected.

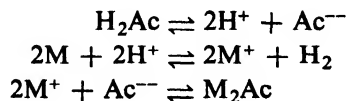
Since nearly all corrosion is an interface reaction, only the exposed surface need be considered. Hence, proper appreciation of these six rate factors, combined with some knowledge of the methods available for decreasing them, should make the study of corrosion and corrosion-resisting alloys much clearer.

### *The Fundamental Factors*

The actual corrosion most frequently results from the presence of favorable conditions of a purely chemical nature. The acidity and the oxidizing characteristics of the environment play a leading role in this respect.

#### ACIDITY

By definition, an acid is a substance which forms hydrogen ions in water solution. These hydrogen ions tend to be replaced by metal ions, especially those of metals which are more active chemically than hydrogen. This forms in the solution a salt of the metal and hydrogen gas, according to the equations:



where  $M$  is any metal and  $Ac$  is any acid radical. These reactions, by themselves, probably will never occur in commercial applications because any evolution of hydrogen would be an immediate sign that the corrosion rate of that metal under those conditions was too great to make the metal usable. However, even if the gas itself were not evolved the tendency would be there, and hence the reaction may be thought of as a force tending to produce corrosion either by corroding the metal itself, or else by acting in conjunction with other forces.

#### OXIDIZING CHARACTERISTICS

By definition, oxidation is an increase in positive valence. The presence of an oxidizing agent, therefore, produces a tendency for any metal, whose valence would be zero, to corrode, or change to a compound or an ion in which it would have a positive valence. This tendency acts in the same direction as that of the acid reaction, and hence the two frequently work together.

The most common oxidizing agent is the oxygen of the air, either acting directly or in liquid solution. Consequently, whenever this oxygen is available, there is a strong possibility either of corrosion or of a definite increase in existing corrosion rates. However, it is also possible for oxygen to decrease the corrosion rate because of its influence on the electrolytic effects which are discussed below.

In *chemical corrosion*, direct chemical attack occurs on the metal part, forming a compound of the metal. This may be considered most simply as a severe type of oxidation since the net effect is to increase the positive valence of the metal.

The most important form of chemical corrosion commercially probably is attack by sulfur or sulfur compounds, forming sulfide corrosion products. An example of this type of attack on a copper alloy condenser tube is shown in Fig. 367. Attack by dry ammonia, dry halides, and many organic compounds in the absence of water also would be of this type. Corrosion in which a metal oxide is formed, i.e., true oxidation, is really a special case of chemical corrosion since it is rarely of importance in the absence of water unless high temperatures are involved as an accelerating factor.

As a result of chemical corrosion the metal surface may be roughened characteristically, as in the example shown, or it may be comparatively smooth. This is largely determined by the nature of the corrosion product formed and by the accelerating factors which are present.

### *The Accelerating Factors*

Once the tendency to corrode is present, the rate at which corrosion occurs generally is determined by the action of the other four factors.

#### ELECTROLYSIS

Electrolysis is the factor which determines most often where the actual corrosion occurs. It is largely an accelerator and is affected greatly by all the other conditions of the reaction. The marked tendency for the anode or positive electrode to go into solution has been mentioned already. This electrode will absorb electrons, and any metal in it will thus tend to go into solution, minus its electrons, i.e., as a positive ion. Simultaneously, at the negative electrode or cathode, hydrogen ions will tend to take on electrons and pass off as hydrogen gas. In electroplating, metal ions instead of hydrogen ions absorb the electrons and deposit on the cathode rather than passing off as a gas. The net effect is, as for the acid reaction, for the electrode metal to replace the hydrogen or metal ion in solution. There are many conditions which may cause this to take place, but all of them generally result in a tendency toward roughening, local corrosion, or pitting which usually is typical of the electrolytic type of corrosion.

The commonest example of electrolytic corrosion generally is termed *galvanic action* since it is the basis of the galvanic cell. Galvanic action occurs when two metals, which have different tendencies to go into solution, are connected electrically and in contact with a conducting solution. This condition may be produced by two entirely different metals or by two pieces of the same metal differing somewhat in chemical composition or in physical condition, as was discussed in Chap. I. An example of selective galvanic attack on one constituent in an alloy because of electrolytic acceleration is illustrated in Fig. 365.

A rough comparison of the chemical activities of some of the important commercial alloys in sea water is given by the listing in Fig. 366. If no complicating factors are present, such a table will give the anodic member of a pair of metals under the conditions shown.

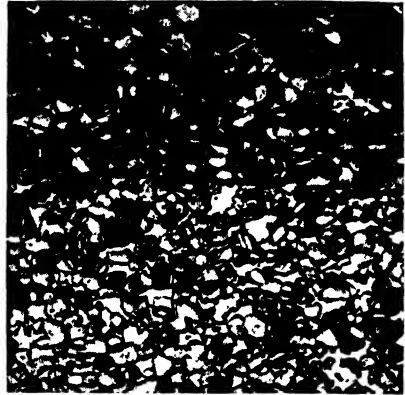


FIGURE 365. A characteristic effect of the electrolytic type of corrosion. De-zincification of Muntz metal (60% Cu - 40% Zn) showing preferential attack on the less noble (anodic)  $\beta$  constituent. (Courtesy Research Department, Chase Brass & Copper Co.)

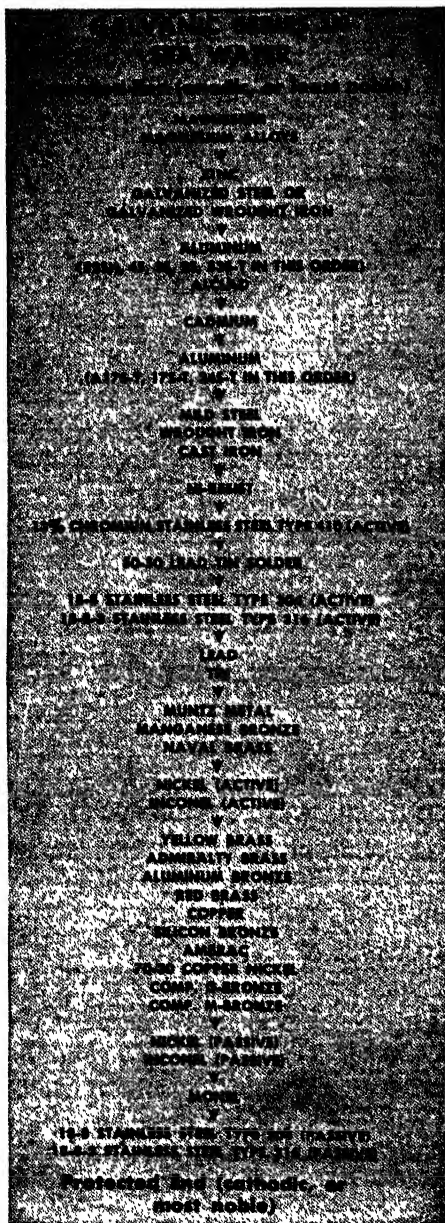


FIGURE 366. Galvanic series of some commercial corrosion-resisting alloys in sea water. Such a table must be used with caution as complicating conditions can modify it markedly. (From *Mechanical Topics*, courtesy The International Nickel Company, Inc.)

Other corrosion of this type results from the presence of concentration cells such as occur when two identical metals are connected electrically and immersed in solutions which differ in concentration, as already has been indicated in Fig. 6. This difference may result from an actual difference in the solutions, from a difference in solution concentration caused by gravity or diffusion, or from a difference in the concentration of dissolved oxygen, e.g., because of a difference in distance from the free surface or other factors.

FILM FORMATION

Any film which is formed during corrosion, and has properties differing appreciably from those of the solution, can have a tremendous effect on the corrosion rate, either decreasing or increasing it. However, in order to give good protection, tests indicate that the film must occupy more volume than the metal from which it is formed.<sup>2</sup>

Two types of films generally are encountered. The first type includes the thicker *visible films* of which rust is an example. They may slow up the reaction by preventing free access of corroding solution; but, on the other hand, they may speed it up appreciably by facilitating the formation of

<sup>2</sup> See also *Protective Films on Metals*, by E. C. Hedges; D. Van Nostrand Company, Inc., New York, 1933.

concentration cells, or, in atmospheric corrosion, by retaining moisture. They usually are discontinuous, and thus prevent access of solution in some places but not in others. The metal under the deposit frequently becomes anodic, and local pitting occurs at that point. This proceeds without interruption. The visible film effect also can be simulated by external conditions; dirt or other foreign matter may settle on the metal and start corrosion even when a natural film is slow in forming.

*Cathodic or passive films* are of the second type. These are, in general, extremely thin and closely adherent films of oxides, such as alumina, which frequently possess unusual properties in addition to the protection they give to the base metal. Some of these films will permit electric currents to flow into the metal, but will resist the passage of ions thus preventing the flow of current in the opposite direction. Many films of this type thus have been important not only because of their corrosion resistance, but also because of their use as alternating-current rectifiers.<sup>3</sup>

#### RATE OF MOVEMENT OR AGITATION

Any corroding reaction, of course, will produce regions of varying concentration at the interface between the metal and the corroding medium. If this change in concentration tends to decrease the rate of the reaction, it should be obvious that any movement of the solution which tends to break down the concentration layer and to restore the original conditions will cause the reaction to proceed more rapidly than it would under static conditions.

Agitation also may interfere seriously with the formation of any films, protective or otherwise, and thus influence the reaction rate. It is, therefore, particularly important in cases of low oxygen concentration which frequently occur because of the comparatively low solubility of atmospheric oxygen in still water. Movement also will tend to equalize concentrations, and thus decrease the tendency to form concentration cells, viz., differences in potential between different parts of the same piece of metal caused by their immersion in different concentrations of the same solution. It readily can be seen, therefore, that it is an important rate factor, although not a primary cause of corrosion.

#### TEMPERATURE

(Temperature is a controlling factor in all chemical reactions, and increasing it, as a rule, tends to speed up the natural rate at which the corrosion

<sup>3</sup> See, for a further discussion, *Industrial Electrochemistry*, 2nd ed., by C. L. Mantell, Chap. XII: McGraw-Hill Book Company, Inc., New York, 1940.





FIGURE 367. An example of a severe type of general or uniform corrosion. An admiralty metal (70% Cu — 1% Sn — rem. Zn) condenser tube which has undergone attack by sulfur compounds in the oil vapors of a heat exchanger. Corrosion product, copper sulfide, has been removed. (Courtesy Research Department, Chase Brass & Copper Co.)

proceeds. Higher temperatures also increase ionization in solutions, increase the mobility of all reacting bodies, and increase diffusion. Their effects on films and film formation may be very important because many films form or do not form depending upon the temperature. In addition, a change in temperature may change the solubility or the form of certain films, and also may reverse the relative chemical activities of metals under given conditions.)

If the temperature range within which a metallic material must be used is much above the normal atmospheric range, the character of the corrosion rapidly approaches a direct chemical rather than an aqueous attack even though water vapor may be involved. As a result, materials used under these conditions must withstand two different effects of heat. First, they must resist oxidation (or other chemical attack), which tends to proceed at a rapid rate and to decrease the effective cross section; and, second, they must retain their mechanical properties to as great an extent as possible.

These two requirements have tended to restrict the so-called heat-resisting alloys to combinations in which iron, nickel, or cobalt is the dominant metal. Alloys based on the other engineering metals tend to oxidize excessively, and generally to deteriorate mechanically at much lower temperatures than those mentioned. It always must be remembered, however, that temperature is relative and that, although iron-, nickel-, or cobalt-base alloys will have the best heat resistance, the alloys of the other engineering metals may be and are used quite satisfactorily within limited elevated temperature ranges lower than those to which the three mentioned are best suited.

Since the effects of temperature for any specific case may be quite varied, it is obviously impossible to make any statement other than that an increase in temperature will probably be harmful.



FIGURE 368. Typical honeycomb pitting in an aluminum brass condenser tube. The tube has been flattened for convenience in photographing. (Courtesy Research Department, Chase Brass & Copper Co.)



FIGURE 369. Effects of impingement type of attack on an admiralty metal condenser tube. (Courtesy Research Department, Chase Brass & Copper Co.)

### *Forms of Corrosion*

Corrosion failures generally are classified under five different headings, dependent to some extent upon which of the rate factors has predominated.

1. **GENERAL OR UNIFORM CORROSION** The entire surface is corroded uniformly as illustrated in Fig. 367. This generally is indicative of a direct chemical type of attack without local acceleration even though the surface may vary from rough to smooth depending on the corroding medium. Measurement of loss of weight per unit of time is a good method for determining the corrosion rate.

2. **PITTING** Local acceleration, which might be caused either by electrolytic or galvanic action, by a film effect, or by concentration cell effects attributable to inhomogeneities in the metal, such as inclusions, metallic impurities, or mechanical defects, will result in a roughened or pitted surface as shown in Fig. 368.

Localized corrosion (Fig. 369) also can result from the *impingement* of gas bubbles against the metal surface as a result of turbulence, or solubility changes.<sup>4</sup> This is one of the most destructive forms of corrosion, and is one

<sup>4</sup> See H. W. Brownsdon and L. C. Bannister, *Journ. Inst. Met.*, London, 49, 1932, 123-130.

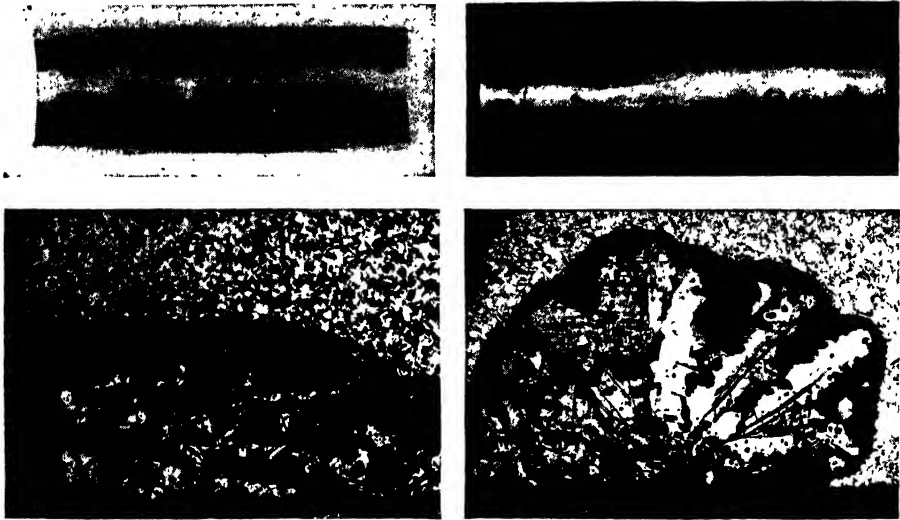


FIGURE 370. Typical examples of plug-type dezincification in copper alloy condenser tubes.

*a.* (Upper) Macrographic appearance in two pieces of yellow brass (2 and 1) pipe.  $\times 1$ .  
*b.* (Lower) Metallographic structure of two corroded sections in admiralty metal condenser tubes. Etched with  $\text{NH}_4\text{OH} + \text{H}_2\text{O}_2$ .  $\times 75$ .  
 (Courtesy Research Department, Chase Brass & Copper Co.)

of the most difficult to guard against. Tensile tests, in which the decrease both in ductility and in the effective strength are measured, or other methods for evaluating the pit depth have been used with good results in many cases.

3. SELECTIVE SOLUTION . Certain alloys, notably those of copper base, are subject to another form of corrosion caused by the selective solution of one or more of their component metals leaving the other behind. This type of attack,<sup>5</sup> illustrated in Fig. 370, generally is referred to as *dezincification*, although alloying metals other than zinc, such as aluminum and manganese, may be affected by it. It may be either *general* or of the *localized plug type* in its action, depending upon the alloy and the corroding conditions.

The attack probably starts when one particular spot corrodes heavily, putting both copper and zinc into solution at once. The more noble copper then is replaced rapidly by the zinc in the surrounding regions, and redeposited practically *in situ*. Thus an effect is secured just as if the zinc had been selectively removed. The redeposited copper is loose and spongy in nature as illustrated in Fig. 370*b*. The most favorable conditions for de-

<sup>5</sup> See, for a thorough discussion, G. D. Bengough and R. May, *Journ. Inst. Met.*, London, 32, 1924, 81-236.



FIGURE 371a. (Left) Brass bowl that failed by season cracking.  
 b. (Right) Brass tubing that cracked in standard mercurous nitrate test.  
 (Courtesy Research Department, Chase Brass & Copper Co.)

zincification seem to be a good conducting solution and a slightly acid condition in the presence of oxygen. It is a serious problem in water pipe and condenser tubes, and in soil corrosion.

4. STRESS CORROSION CRACKING — Some failures result from the combined effects either of corrosion and static stresses, or of corrosion and dynamic stresses. In stress corrosion cracking<sup>6</sup> the stresses are usually static and caused by an external load. However, they may also result from internal stresses retained after previous cold-working operations, in which case the failure frequently is termed *season cracking*<sup>7</sup> (Fig. 371a). Cold-worked brasses, containing more than about 20% zinc, and sometimes *Monel metal* and certain aluminum- and magnesium-base alloys, are particularly susceptible to this type of failure.<sup>8</sup> The tendency toward season cracking can be removed almost completely either by full annealing, which will soften the metal simultaneously, or by a stress-relief anneal just below the recrystallization temperature which will relieve the internal stresses without changing the mechanical properties.<sup>1</sup> In some instances, such as Medart straightening of brass rod (cf. Chap. X), suitable mechanical treatment also is effective.

<sup>6</sup> See J. C. Hodge and J. L. Miller, *Trans. A.S.M.*, **28**, 1940, 25–67.

<sup>7</sup> See, for example, D. K. Crampton, *A.I.M.E. Tech. Pub.* 297, 1930, 3–18.

<sup>8</sup> The *A.S.T.M.-A.I.M.E. Symposium on Stress Corrosion Cracking*, 1944, gives an excellent survey of this subject.

Failures as a result of stress corrosion are generally intercrystalline in nature (cf. Fig. 410c). Susceptibility to this type of attack can be tested by (a) actual stress corrosion tests, either under service or under accelerated conditions; or (b) immersion in standard accelerating solutions such as mercurous nitrate or ammonia solutions. For copper-base alloys, in particular, the standard season cracking or strain test, immersion in mercurous nitrate solution of definite strength as described completely in A.S.T.M. Standard B154, commonly is used to determine the magnitude of internal stresses (cf. Fig. 331). A brass tube that has failed in this test is shown in Fig. 371b.

5. CORROSION FATIGUE Corrosion fatigue<sup>9</sup> is the product of two factors: (a) fatigue stress, which is increased markedly by surface corrosion especially if the corrosion is of the pitting type; and (b) corrosive action, which is accelerated by fatigue stresses. Even ordinary tap water has been known to accelerate markedly this type of failure.<sup>10</sup>

Corrosion fatigue failures usually show a typical fatigue crack extending from a notch, as at the base of a pit. The cracks usually are transcrystalline (cf. Fig. 410b).

#### CORROSION TESTING

All laboratory corrosion tests are accelerated tests, designed to approximate actual operating conditions. As accelerated tests they are open to question. Various types are used,<sup>11</sup> most of which are self-explanatory, and some of which are illustrated in Fig. 372. Among these may be mentioned waterline tests; alternate immersion; total immersion; impingement, in which a continuous stream of air bubbles is directed against the surface while it is immersed in the corroding medium; and all kinds of chemical exposure tests. Recommended practice for conducting plant corrosion tests is given in A.S.T.M. Standard A224, and for conducting salt-spray tests in Tentative Standard B117-T.

Loss in weight, loss in tensile strength and ductility, and general appearance are the methods used most frequently for evaluating any of these tests.

In general, it may be stated that corrosion tests should approximate actual operating conditions as closely as possible, but even then the necessity for acceleration will make the results of value from, at best, a semiquantitative or "weeding out" viewpoint. In the field of corrosion, the only certain way of finding out how a given material will act is to try it out under

<sup>9</sup> See H. J. Gough, *Journ. Inst. Met.*, London, **49**, 1932, 17-92.

<sup>10</sup> See, for example, D. J. McAdam, Jr. and G. W. Geil, *Trans. A.S.M.*, **30**, 1942, 1159-1198.

<sup>11</sup> See, for a complete discussion, *A.S.T.M. Symposium on Corrosion Testing Procedures*, 1937.

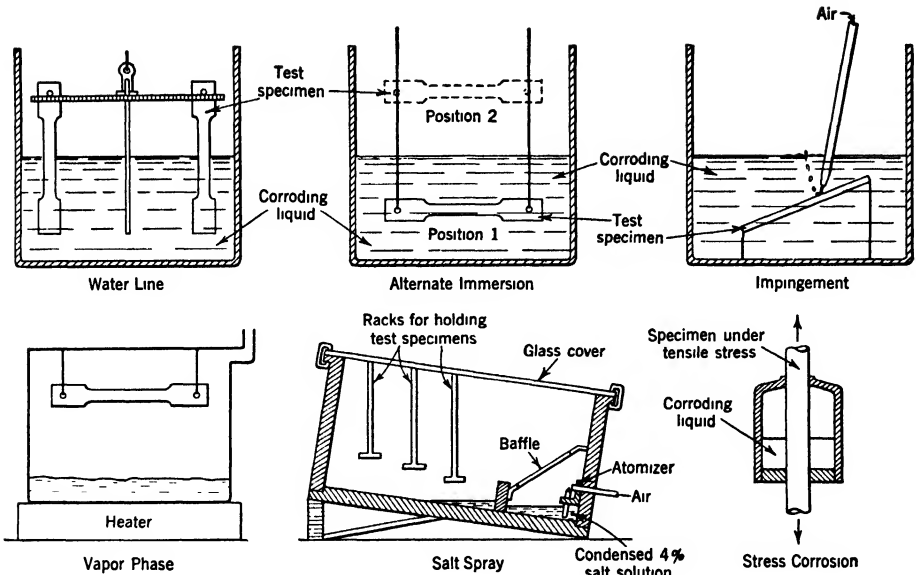


FIGURE 372. Schematic representation of several common types of laboratory corrosion tests. All of these are accelerated tests conducted under controlled and reproducible conditions and hence are of value only in determining comparative resistance to that particular type of corrosion.

actual service conditions. Because of the long times required and the dangers incident to possible failure, however, this is seldom possible.

### *Metals and Alloys Resistant to Corrosion*

It is convenient to discuss the corrosion-resistant materials according to the types of corroding media which they usually are required to withstand, even though such a classification necessarily is a rough one entailing many duplications. In cases where the principal applications of a given material are determined by its strength, wear resistance, or special physical properties, it will be discussed elsewhere in conjunction with the materials with which it competes even though its corrosion resistance may be quite adequate for most purposes.

Under this classification three general groups of corrosion-resistant materials will be considered:

1. Alloys which combine formability or workability with some corrosion resistance. These materials usually are comparatively inexpensive, and have few, if any, outstanding mechanical characteristics. They seldom are required to withstand more than moderate loads or conditions more severe than those of atmospheric corrosion.

2. Alloys which combine formability with resistance to aqueous and the milder forms of chemical corrosion. The cost of these materials usually is higher than those in the first group.
3. Alloys which are fairly resistant even to reasonably severe chemical corrosion, and frequently possess satisfactory heat-resisting properties in addition. These materials are apt to be somewhat more expensive than those of the other two groups, and their mechanical characteristics are liable to vary over a comparatively wide range. In many cases they are the only materials available to resist certain chemicals, and hence designs using them must be based on the characteristics available rather than vice versa.

#### ECONOMIC FACTORS RELATIVE TO CORROSION- AND HEAT-RESISTING MATERIALS

As a general rule, the more resistant to corrosion a given material is, the greater will be its unit cost and the more difficult it will be to fabricate. Although certain of the commercially pure metals and some of the simpler alloys may contradict this statement to some extent, these materials usually do not possess the accompanying mechanical properties which would make them of the greatest value in engineering, except possibly as claddings on stronger bases. Hence, the engineer continually is faced with an economic problem in which, practically, corrosion resistance is of only secondary importance because, usually, the corroding conditions are established and cannot be changed. First consideration usually must be given to ease of fabrication and to the mechanical properties consistent with the particular design in question. In only a comparatively few cases will it be found that an entirely satisfactory combination of mechanical properties, ease of fabrication, corrosion resistance, and reasonable cost can be secured. If the desired corrosion resistance cannot be secured along with these other characteristics, then some of the various methods of surface protection must be relied upon to minimize the effects of corrosion.

Because, as has been pointed out previously, corrosion resistance is difficult to estimate from other than actual service experience, the commonest procedure is to design on the basis of the usual engineering materials, selecting from those available the alloy which appears to be most likely to resist the corrosion, and then to give as much added protection as possible by the use of protective coatings and sizable factors of safety.

One of the principal factors to avoid in design is the simultaneous use of different materials in aqueous or other conducting solutions, especially when such materials are connected together electrically. Under these con-

ditions, even though the individual materials may have an extremely high resistance to corrosion independently, the combination, because of the electrochemical effects involved, may fail comparatively rapidly.<sup>12</sup> If the connected dissimilar metals are to be used dry, so no galvanic action is possible, this point is relatively unimportant, however.

*Neither a high initial cost nor clever advertising is a guarantee of corrosion resistance.*

*For Further Study Refer to*

1. *Corrosion Resistance of Metals and Alloys*, by R. J. McKay and R. Worthington: Reinhold Publishing Corporation, New York, 1936.
2. *The Corrosion of Iron and Steel*, by J. C. Hudson: D. Van Nostrand Company, Inc., New York, 1940.
3. *Metals Handbook*: American Society for Metals, Cleveland, Ohio, 1939 (usually published triennially). A new edition will appear in 1948.
4. *Corrosion Causes and Prevention*, by F. N. Speller: McGraw-Hill Book Company, Inc., New York, 1935.
5. *Reports of the Corrosion Committee*: The Iron and Steel Institute, London (published at irregular intervals).
6. *Metallic Corrosion*, by U. R. Evans: E. Arnold & Co., London, 1937.
7. *Symposium on Stress Corrosion Cracking of Metals*: American Society for Testing Materials—American Institute of Mining and Metallurgical Engineers, Philadelphia, Pa., 1945.

<sup>12</sup> For a striking example see *Eng. News*, 74, 1915, 514, 522.



## XII

# Protecting Metals Against Corrosion

ALL MATERIALS CORRODE TO SOME EXTENT. HOWEVER, THE rate at which they do so varies markedly with the conditions of exposure, as shown in the preceding chapter. Unfortunately, it frequently is found that the materials which resist corrosion suitably are deficient themselves in other mechanical or physical properties or are too expensive to be practical. Consequently, the next best thing is to use the corrosion-resistant material as a coating merely to protect the underlying base metal which is the actual engineering material.<sup>1</sup>

### TYPES OF PROTECTIVE COATINGS

In general, protective coatings may be applied by any of eight methods:

1. Hot dipping
2. Electroplating
3. Cementation
4. Metal spraying
5. Metal cladding
6. Protective film formation
7. Painting
8. Vitreous enameling

Other methods have been used but these are the principal ones.

The various carbon steels are protected most frequently by these coatings because of their otherwise relatively rapid corrosion rate and unsightly corrosion product, rust. However, protective coatings also are valuable in some instances for protecting aluminum and magnesium alloys against specific types of corrosion, such as marine, because of the comparatively high chemical activities of these metals and the inherent galvanic nature of the combination of constituents in their high strength alloys. Protective coatings also are used with all sorts of materials to change or improve their appearance.

<sup>1</sup> This entire subject is discussed well in *A.S.T.M. Symposium on Protecting Metals Against Corrosion*, 1938.

Surface treatments frequently are used to produce a surface layer which has mechanical properties different from those of the base, but these will be discussed in a later chapter.

#### TYPES OF PROTECTION

The suitability of a protective coating depends to a large extent on the base metal as well as on the coating itself. In general, the protection is either purely *physical*, protecting by shielding the base metal from the corroding medium; or else *chemical*, protecting by being more active chemically than the base metal and thus corroding in preference to it. When physical protection is the only result it is usually advisable to supplement the protection by paint or some similar medium. This even may be desirable when chemical protection is afforded because such protection definitely is limited in extent and usually is inoperative over any but small exposed areas.

#### *Hot Dipping*

(Hot-dipped coatings are usually of relatively low melting point. Zinc, tin, lead, or an alloy of tin and lead called *terne*, and, infrequently, aluminum coatings customarily are applied by this method. In order to secure a satisfactory hot-dipped coating it is essential that the operation be conducted under conditions of extreme cleanliness. The molten metal must wet the base metal and alloy with it for easy coating.) especially from a commercial viewpoint. In cases where this is difficult, either the process of "tinning," i.e., preliminary coating of the base with a metal which will alloy both with it and with the true coating, or the addition to the coating of elements which will alloy with the base metal, must be used.

(For coating a steel base a *zinc* (*galvanized*) coating gives better protection than either a *tin* or a *terne* plate because of the relative chemical activities of the metals concerned. Zinc is more active than iron, whereas tin and lead are less active. Hence in case of a break in the coating, the zinc would tend to corrode preferentially, leaving the iron bright, whereas if tin or lead alloys were used the iron would tend to corrode in preference to the coating, thus forming a rust streak in the plate.) This form of galvanic protection is effective for areas up to about  $\frac{1}{4}$  in. diameter, but it is supposed to be unreliable for larger areas, even though cases are well known and are cited in the literature in which claims to much greater degrees of protection are made.

(Zinc galvanized coatings are unsuitable for the preparation and storage

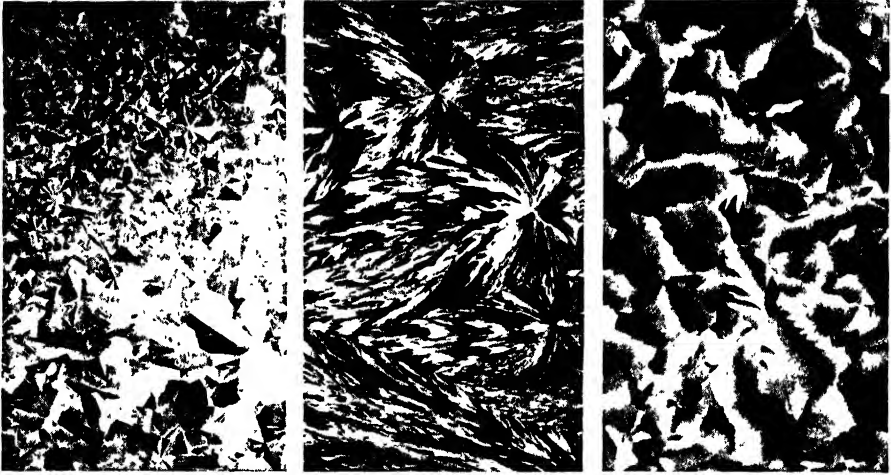


FIGURE 373a. (Left) Surface appearance of galvanized iron sheet. Natural size originally; reduced somewhat in reproduction. b. (Center; right) Surface appearance of etched tin plate. Etched with alcoholic acid ferric chloride.  $\times \frac{3}{4}$  originally; reduced about one half in reproduction. Center, coke tin plate, 1.51 lb per base box. Right, charcoal tin plate, 6 lb per base box. (Photographs courtesy O. E. Romig and D. H. Rowland.)

of foods, especially acid foods, even though they are probably nontoxic, whereas tin coatings are quite satisfactory. Under certain conditions of acidity, the tin may even become anodic to the iron, and thus give the electrochemical protection which is normally absent. A lead-tin alloy, 75% Pb-25% Sn, is used commonly for terne plate although wide variations in this composition are found. However, neither it nor lead is ever used for food preservation because of their toxic qualities. In case of a shortage in tin for the purpose of tinning iron cans for food preservation, an electrodeposited tin plate which is much thinner than the hot dipped variety is probably the best substitute. However, thin silver electrodeposits and some types of lacquer coatings, which are relatively inactive chemically, have been found to be quite satisfactory, both chemically and economically, for some foods even though they are totally unsuitable for others.

(Tin plate is usually quite bright in appearance. Terne (and lead) is much duller, and galvanized coatings (Fig. 373) are distinguished easily by their spangled appearance. This spangle is produced by a controlled impurity content and the formation of large grains of zinc during solidification, and has become practically a trade-mark of this type of material. A similar effect is sometimes found on tin and terne plate, but it is neither produced so deliberately nor is it so well defined as on zinc. Etching brings it out clearly on tin plate, however, as shown in Fig. 373 also.

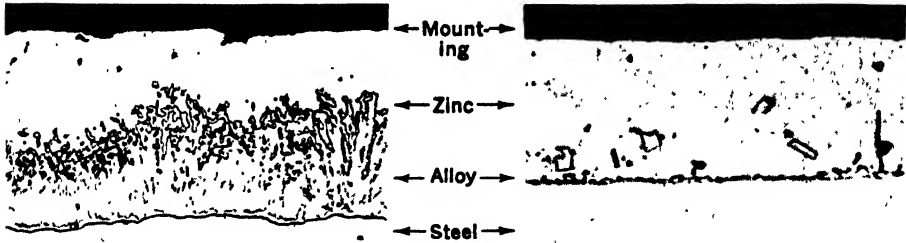


FIGURE 374. Metallographic structure of cross sections through hot-dipped zinc (galvanized) coatings on steel after polishing with pH controlled abrasive. *Left*, commercial coating, average weight 1.58 oz per sq ft. Etched with nitric acid in amyl alcohol.  $\times 1000$ . *Right*, coating containing approximately 0.20% aluminum average weight 1.44 oz per sq ft. Etched with nitric acid in amyl alcohol.  $\times 500$ . (Photomicrographs courtesy D. H. Rowland and O. E. Romig.)

#### GALVANIZING

The thickness of zinc coatings is measured in ounces per square foot of surface for all products except sheet, where ounces per square foot of sheet is used, i.e., twice the average weight of coating per square foot of surface since the sheet is coated on both sides (1 oz per sq ft corresponds roughly to a thickness of about 0.002 in.). The desirable thicknesses for many uses are covered by several A.S.T.M. Standards.

Galvanized or hot-dipped zinc coatings on iron usually are composed of at least two layers, the nature of which is illustrated in Fig. 374. Below the outer layer of substantially pure zinc there are one or more layers of definite iron-zinc compounds, probably  $\text{FeZn}_7$  (10.9% iron) and  $\text{FeZn}_3$  (22.16% iron). These compounds are relatively hard and brittle and their presence tends to make the sheet less ductile, a thin even alloy layer being the most desirable. Methods for safeguarding against and for detecting embrittlement in hot-dipped zinc coatings are given in A.S.T.M. Standard A143. The purity of the zinc has an effect on the bending properties and the appearance of the coating, but, aside from this, the grade of zinc used has no known effect. Hence, relatively low grades usually are used. Galvanizing is used in the greatest tonnage for coating iron and steel, and its protective effect is determined almost entirely by the thickness and tightness of the coating. The method of application, the purity, and the degree of alloying are relatively unimportant. Heavy coatings may be more cheaply applied by hot dipping than by any other method, but their adherence when bent may not be too good.

The *Preece test* (copper sulfate dip) for determining the uniformity of

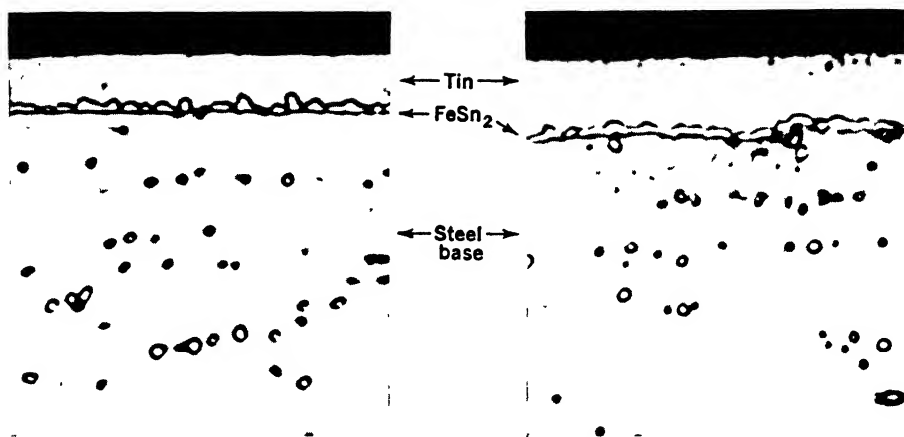


FIGURE 375. Metallographic structure of cross sections through tin plate. *Left*, coke tin plate, average weight of coating 1.46 lb per base box. Double etched with (1) nitric and hydrofluoric acids in glycerine, and (2) 5% picral, to reveal  $\text{FeSn}_2$  alloy layer.  $\times 2500$ . *Right*, charcoal tin plate, average weight of coating 3.75 lb per base box. Double etched with (1) weak alcoholic hydrofluoric acid, and (2) 5% picral, to reveal  $\text{FeSn}_2$  alloy layer.  $\times 2500$ . (Photomicrographs courtesy O. E. Romig.)

galvanized coatings on iron or steel articles is described in A.S.T.M. Standard A239.

### TIN PLATE

Tin coatings have an excellent appearance, resist corrosion, and give a surface which may be readily soldered. Tin plate is measured and sold by the *base box*, a base box consisting of 112 sheets of 14 in. by 20 in. plate, or 31,360 sq in. of any size and 62,720 sq in. of surface to be coated. In this country a base box generally carries about 1.35 lb of tin, a coating of about 0.00007 in. in thickness. The range is from 1–2.5 lb per base box, i.e., 0.000059–0.000146 in.

The structures of two types of coatings are illustrated in Fig. 375. Under a surface layer of relatively pure tin is found a layer, about 0.00002 in. in thickness, of rectangular crystals of the tin-iron compound  $\text{FeSn}_2$  (80.9% tin).

Tinned copper and copper alloys also are employed widely, especially where the higher cost can be justified. In this case the tin should protect electrochemically as well as physically. However, with hot-dipped coatings a very thin layer of copper-tin alloy may be formed between the coating and the base metal. Usually such a layer is cathodic to copper and hence would actually tend to accelerate the chemical attack on the copper if both were exposed to a corroding medium simultaneously.

## TERNE PLATE

Terne plate is made in a manner quite similar to tin plate. The unit in this case, however, is usually the *double base box*, i.e., 112 sheets 20 in. by 28 in., and the range of coatings varies from 12–40 lb per double base box.

Frequently terne plate, rather than lead, must be used on iron and steel, because the lead is insoluble in both solid and liquid iron, and hence there is little tendency for it to alloy. However, pure chemical or antimonial lead may be used occasionally. In such cases it can be applied either by pouring or by “burning” it on, i.e., melting it as in lead welding.

The protection of terne coatings is purely mechanical, and sheets exposed to corrosion must be kept painted, preferably with an acid-resisting paint. The coatings have excellent paint-holding properties.

## HOT-DIPPED LEAD COATINGS

Most of the so-called lead coatings applied to steel by hot dipping contain up to 2½% tin and about 2% antimony. The addition of these elements increases the hardness of the coating metal appreciably. Three common alloys available commercially for lead coating are sold under the names: *DW Metal*, *Plate-loy*, and *Amaloy*. Lead-coated wire and sheets are sold under the trade name *Lead Sealed* by one of their first producers.

Hot-dipped lead coatings of thicknesses comparable to terne plate tend to show pinholes and hence a rather thick (20-lb) coating commonly is used as a substitute for the thinner (8-lb) terne coating. A lead coating will run ordinarily about 0.7–0.8 oz per sq ft of sheet, whereas a comparable zinc coating will be about 1.15 oz per sq ft of sheet. Lead coatings solder readily, take paint well, and do not tend to embrittle the steel base, since they form no compounds with it. However, especial care must be taken in applying them to ensure a perfectly clean surface, and usually immersion in a molten flux bath is included as a preliminary step to immersion in the flux-covered lead bath.

## APPLICATIONS INVOLVING HOT-DIPPED COATINGS

Hot galvanized steel: Roofing and siding sheets, wire and wire products for all outdoor exposure, hardware for outdoor use, pipe and conduit, and exposed structural steel.

Tin: Tin cans (steel containers for food), tinned wire, tinned copper roof-

ing sheets, tinned copper tubing for refrigeration systems especially in the milk and beer industries.

**Terne:** Roofing sheets, ventilators and hoods carrying corrosive gases, deep-drawn articles such as gasoline tanks, burial caskets, so-called lead-coated and lead-lined equipment, metal furniture, oil cans, and other containers of a nonfood variety.

**Lead:** Substitute for terne coatings in most and for galvanized coatings in many applications.

### *Electroplating*

Essentially, an electroplating installation consists of: (a) a *cathode*, or negative electrode, which is the object to be plated; (b) a *bath*, a conducting liquid containing either molten salts or an acid or alkaline, aqueous or organic solution of salts of the metal or alloy to be deposited; (c) an *anode* or positive electrode, which may be either *soluble*, in which case it consists of the metal or alloy being deposited from the solution and its function is to replenish continually the concentration of the solution, or *insoluble*, in which case oxygen will be evolved and the concentration of the bath must be kept up by periodic additions of metal salts; and (d) a *source of direct current*, which may be either a rectifier or a d-c generator.<sup>2</sup>

The metals most frequently electroplated commercially are zinc, copper, nickel, chromium, and tin. Iron, cadmium, lead, the precious metals, and certain alloys are electroplated to a somewhat lesser extent, and nearly any metal can be electroplated under properly controlled conditions. Requirements for electrodeposited coatings of nickel and chromium on steel, and zinc-base alloys are covered by A.S.T.M. Tentative Standards A166-T and B142-T respectively; and those for electrodeposited coatings of cadmium and zinc on steel by Tentative Standards A165-T and A164-T. Requirements for electrodeposited coatings of nickel and chromium on copper-base alloys are given by A.S.T.M. Standard B141.

The process of electroplating is a complex one and a careful control of the chemical composition, the temperature, the cleanliness of the bath, and the cathode current density,<sup>3</sup> is required for good deposits. Generally, the current density is maintained as high as is consistent with good deposits in order to speed up the ordinarily slow process. For a given set of plating conditions the thickness of the usual deposit is proportional to the time of deposition.

<sup>2</sup> For a thorough discussion, see W. Blum, A. O. Becknen, and W. R. Meyer, pp. 7-56, in Ref. 2 at the end of this chapter.

<sup>3</sup> The cathode current density is the ratio of the current through the cell to the surface area of the cathode.

## PROTECTING EFFECTS OF DEPOSITS

All electrodeposits are porous to some extent. Consequently, for best results they should protect the base metal chemically as well as physically. However, except for the case of zinc coatings, this seldom is achieved with steel because the coating is almost invariably of a lower chemical activity than the steel base. To overcome this difficulty the physical protection of the coating may be increased by such methods as polishing the underlying deposits in order to cover the pores in them by flowing metal into them.

Coatings on nonferrous materials of lower chemical activity than steel, such as the brasses and copper, will frequently give chemical as well as physical protection.

## STRUCTURE OF DEPOSITS

The structure of various types of electrodeposits is illustrated in Fig. 376. It can readily be appreciated from *a* why high magnifications must be used. In *b* is shown a typical columnar deposit of copper in which crystals of the deposited metal have grown perpendicularly to the surface of the base metal, forming large columnar crystals. In *c* is shown a fine-grained randomly oriented copper deposit; and in *d* an extremely fine-grained, banded bright nickel deposit produced by adding organic or other addition agents to the bath. Frequently, as in *e*, it will be found that the structure of the electrodeposit is a direct continuation of the structure of the underlying base metal.

## GENERAL CHARACTERISTICS OF ELECTRODEPOSITS

Electrodeposits are used because of their excellent appearance, as well as the added corrosion resistance which they impart. In almost every case preliminary polishing and buffing will improve appearance. This is frequently done although, since it is an expensive operation, much study has been given to methods for eliminating it. Certain organic additions to nickel<sup>4</sup> and copper baths tend to give, with the proper plating conditions, very fine-grained deposits which are bright in appearance, although frequently very hard and relatively brittle. Proper control of the orientation of the deposited crystals also seems to help; and, in addition, gives a much softer and more workable plate.

Electroplated coatings, regardless of the metal used, are apt to be rela-

<sup>4</sup> See, for example, L. W. Johnson, *Met. Ind.*, London, **50**, 1937, 281.



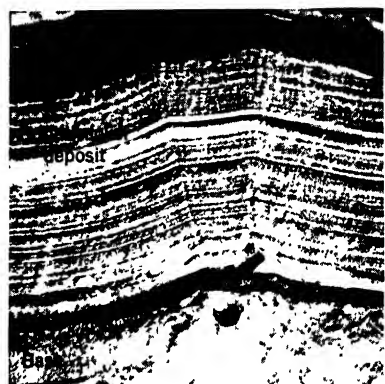
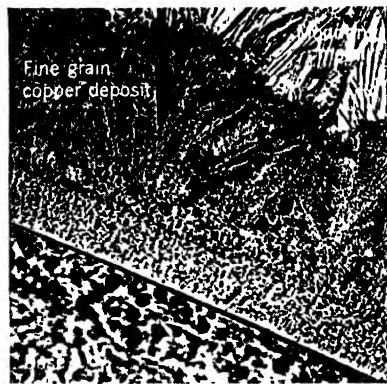
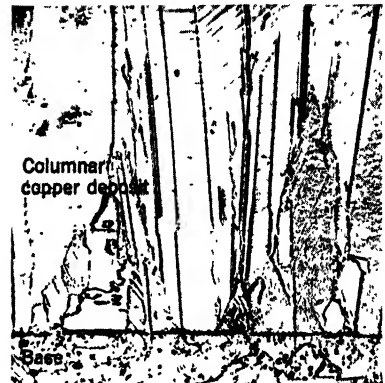
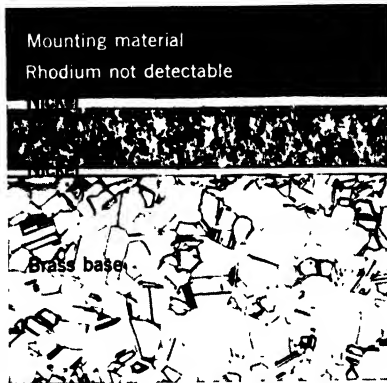


FIGURE 376. Metallographic structure of various types of electrodeposits.

*a.* (Top left) Brass, plated with successive deposits of nickel, copper, nickel, and rhodium. Etched with  $\text{NH}_4\text{OH} + \text{H}_2\text{O}_2$ .  $\times 200$ . (Photomicrograph by L. Litchfield.) This illustrates how little of the structure of even relatively thick electrodeposits can be seen at low magnifications.

*b.* (Top right) Copper deposited from an acid solution, showing reproduction of the structure of the base metal by a columnar deposit that is apparently twinned.  $\times 1000$ .

*c.* (Middle left) Copper deposited with a grain so fine it has barely been resolved metallographically.  $\times 1000$ . The nodular type growth is caused by the presence of metallic impurities in the copper-plating solution.

*d.* (Middle right) Bright nickel deposit illustrating characteristic banded structure.  $\times 1000$ . This structure also is very fine and nearly unresolved.

*e.* (Bottom left) Almost perfect reproduction of the copper base by copper electro-deposited from an acid solution on a base deeply etched with nitric acid.  $\times 1000$ .

(Photomicrographs *b* through *e* courtesy Walter Meyer, The Enthone Co., New Haven, Conn.)

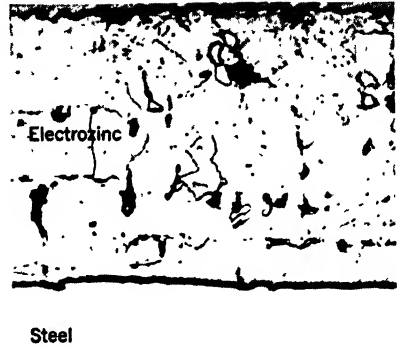
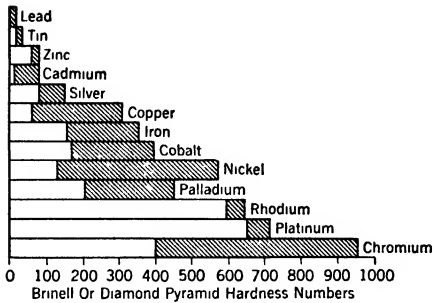


FIGURE 377. (Left) Brinell Hardness range of various electrodeposited coatings. (After A. W. Hothersall, from Ref. 1 at the end of this chapter, courtesy Reinhold Publishing Corporation.)

FIGURE 378. (Right) Metallographic structure of cross section through an electrozinc coating on steel wire. Etched with 5% HCl.  $\times 1000$ . (Photomicrograph by L. Litchfield.)

tively thin, approximating a few ten thousandths of an inch or less. However, hard deposits of both chromium<sup>5</sup> and nickel<sup>5</sup> have been used in sufficient thickness to build up worn shafts and bearing surfaces, and other parts subject to wear and erosion.

Electrodeposited coatings, in general, have the advantage of high purity. As a result, ductile deposits will often withstand severe bending and other mechanical deformation very much better than will other coatings of similar thickness. This purity also helps to increase their resistance to corrosion in many instances.

The Brinell hardness range of various electrodeposited coatings is shown in Fig. 377. If hydrogen is codeposited with the metal its hardness and brittleness may be increased markedly. However, the true hardness and ductility of the coating usually can be restored by a low-temperature baking to drive off the gas.

### ZINC PLATING

↳ Electrodeposited zinc has certain definite advantages over similar coatings produced by hot dipping. As illustrated in Fig. 378, there are no apparent layers of iron-zinc compounds between the base metal and the coating. Although this probably has little effect on corrosion resistance, it does influence markedly the ductility of the deposit which is very important in some applications. Electrozinc coatings, however, are seldom thicker than

<sup>5</sup> See, for a further discussion, A. Fletcher, *Metal Finishing*, 40, July, 1942, 355-358; C. F. Bonilla, *Trans. Electrochem. Soc.*, 71, 1937, 263.

0.0005 in., much thinner than corresponding dipped coatings. Modern methods of rapid electrodeposition have made electrozinc a real competitor of the hot-dipped product, especially in wire and wire products,<sup>6</sup> which can be most readily handled on a continuous basis. However, steel sheet, such as that used for the wartime substitute 1-cent piece, can also be electrogalvanized successfully in modern plants.<sup>7</sup>

The adherence of zinc electrocoatings is generally much greater than that of coatings produced by hot dipping.<sup>8</sup> In the case of electrogalvanized rivets, for example, the coating adheres to some extent even after the rivets have been driven. However, this improved adherence may result as much from the absence of brittle intermetallic compounds between the electrodeposited coating and the base metal as from any other cause.

Zinc plating solutions in use today are of two general types: (a) *cyanide solutions*, having good throwing power and depositing either dull or bright deposits; and (b) *acid solutions*, having poor throwing power but depositing smooth, white deposits.

By *throwing power* is meant the ability of the bath to deposit the minimum desired thickness of plate upon the least accessible portion of the cathode while depositing as little metal as possible in excess of this minimum on the other portions of the cathode surface. A bath with good throwing power will, therefore, tend to give a uniform deposit over the entire cathode surface regardless of its shape, whereas one with poor throwing power will deposit very little metal in irregularities or other inaccessible portions of the cathode surface. Baths with good throwing power have broad utility but those with poor throwing power generally are limited to plating regularly shaped articles unless complicated anodes are used.

The cyanide solutions are alkaline and conform to several different patented compositions. They are used both for still or for barrel plating. *Barrel plating* generally is preferred for small objects that would be too expensive to rack or hold individually so, instead, they are placed in a rotating metal barrel and the entire mass becomes the cathode, uniformity of deposit being secured by rotating the barrel, thus tumbling the work. All the cyanide zinc solutions use soluble anodes, either rubber-lined or plain steel tanks, and operate in the vicinity of 100 F (38 C), with current densities of the order of 10–25 amp per sq ft and cathode efficiencies of about 90%. To deposit bright zinc it is usually necessary to use patented purifiers, addition agents, or bright dips. Depending upon the type of protection desired, minimum thicknesses of the order 0.00015–0.001 in. usually are deposited.

<sup>6</sup> *Bethanized wire* is a commercial example of this type of product.

<sup>7</sup> See, for example, G. G. S. Adey, *Sheet Metal Industries*, 16, Sept. 1942, 1509–1514.

<sup>8</sup> See, for example, *Product. Eng.*, 13, Oct. 1942, 564–566.

Acid zinc plating, because of its poor throwing power, finds its greatest utility for plating wire, strip steel, wire cloth, and pipe when a smooth rust-resistant coating is more important than a bright one. The acid baths are used in rubber- or lead-lined tanks and also are operated at about 100 F (38 C). If the  $pH$  is maintained in the vicinity of 5–5.3, current densities of 5–50 amp per sq ft generally are used for still solutions. However, by dropping the  $pH$  to 3.5–4.6, and agitating the bath, these can be increased to 50–100 amp per sq ft; and by using an acidity of 0.1–4.0 N (by titration), and agitating, the current density can be increased as high as 100–500 amp per sq ft, with accompanying speeding up of deposition, of course. Special anodes which dissolve or corrode very evenly must be used and for deposits over 0.0002 in. thick it is customary to bag the anodes and filter the solutions. Brighteners usually are added to the solution as required.

If desired, zinc coatings can be blackened by first bright dipping, washing thoroughly, and then immersing in heated solutions of the proper composition. Usually these contain double nickel salts but several other types are available commercially.

#### COPPER PLATING

Copper deposits are used most frequently for ornamental purposes, as an undercoat for other metals, or to build up appreciable thicknesses in applications such as electrotyping or electroforming. Two types of solutions generally are used: (a) the *alkaline solutions* of the cyanide, or Rochelle salt (potassium sodium tartrate) and cyanide types, which are used primarily for deposits in which appearance rather than thickness is the primary consideration, and (b) the *acid solutions*, which are used when thick deposits are desired, frequently over a thin undercoat of cyanide copper.

The older cyanide baths seldom operated at more than 100 F (38 C) and 10 amp per sq ft, and usually had such low cathode efficiencies (60% was considered good) that they were not too practical. To overcome these disadvantages the Rochelle salt type of cyanide solution was developed. This solution operates at a  $pH$  of about 12.6, a temperature of 150 F (65 C) and a current density of 20–60 amp per sq ft. Cathode efficiencies are generally of the order of 40–70% and thicknesses of 0.0001 in. can be deposited in 2–4 min depending upon the exact conditions.

Acid copper baths generally contain sulfuric acid and are operated at about 100 F (38 C) with current densities of 15–40 amp per sq ft. By using air agitation and adjusting the concentration and temperature properly, current densities as high as 75–150 amp per sq ft are possible.

Bright deposits can be secured if the temperature,  $pH$ , current density, and agitation are adjusted properly. In addition several patented addition agents and solutions are available commercially for producing bright deposits. Because copper frequently is used as a heavy undercoat for nickel and chromium, the appearance of both of which is affected by the appearance of the undercoat, it must either be buffed or polished, an operation which not only is expensive but also is apt to cut through the plate and expose the base metal, or else deposited in a form sufficiently bright that no other treatment is necessary. This is the main reason for the commercial interest in smooth, bright deposits.

#### NICKEL PLATING

The combination of physical, mechanical, and chemical properties possessed by nickel makes it particularly desirable as a plated finish. In addition it is the best undercoat available for chromium, with which it is used most commonly, and for palladium and rhodium.

The time-honored nickel solution is used at room temperature and contains either the so-called double nickel salts (nickel ammonium sulfate) or else the single salts (nickel sulfate) plus ammonium chloride. The  $pH$ , which is maintained at 5.4–6.0, is somewhat easier to control with the single salts than with the double salts solution. When controlled properly, this bath gives a ductile deposit which is dull white in color although it can be brightened appreciably by the use of addition agents.

Modern "bright nickel" baths are mostly of the Watts type although they are usually proprietary baths of definite composition and contain specific addition agents. Complete information concerning the proprietary baths can be secured best from the various chemical companies offering them commercially. In general, the Watts type of bath contains both single nickel salts and nickel chloride and operates at a  $pH$  of 5.2–5.8, a temperature of 140 F (60 C), and a current density of 15–50 amp per sq ft. Agitation of the work or the solution, or both, permits high current densities to be used but also necessitates filtering the solution continuously if high quality deposits are to be secured.

#### CHROMIUM PLATING

The general hardness and chemical resistance of chromium deposits make them ideal for applications for which these characteristics are desired. Chromium deposits can generally be classified either as *decorative*, in thicknesses of 0.00001–0.00003 in., or as *hard* or *industrial*, in which wear

resistance is most important and thicknesses are usually at least 0.003 in. for heavy service but may vary from 0.0003 to 0.050 in.

Chromium - plating solutions contain, essentially, chromic acid ( $\text{CrO}_3$ ) and certain acid radicals such as sulfate or fluoride which facilitate the plating of the chromium without themselves entering into the reaction. The essential factor is that the ratio of chromic acid ( $\text{CrO}_3$ ) to acid radicals, expressed as sulfate ( $\text{SO}_4$ ), should be about 100/1. Bright chromium deposits are secured by first preparing the surface so it has the appearance

desired in the finished part and then plating at a temperature of about 105 F (40 C) and a current density of 115 amp per sq ft. Cathode current efficiencies are low, running only about 10–15%. Insoluble anodes are used, generally of lead or steel, and, because the throwing power of the solution is very low, their shape and position will influence the deposit appreciably. If conditions are not controlled properly deposits will be “dull,” “frosty,” or “milky” rather than “bright.” This is illustrated in Fig. 379 for deposits on various base metals. Articles to be chromium plated also have to be racked properly if good deposits are to be secured. Efficient racking is an art which can be learned only through experience.

For some applications, such as the plating of saws, drills, and molds for rubber or plastic, hard deposits of 0.001 in. or less are entirely adequate to increase wear resistance and life several-fold. Above 0.010 in. the deposits are used primarily for building up worn or undersize parts. However, between 0.001 and 0.010 in. hard chromium deposits find their greatest utility and are used on shafts, spindles, headings, rolls, gauges, and similar parts to increase wear resistance. Deposits greater than 0.001 in. must be finish-ground or lapped to size.

Hard chromium deposits are secured by operating a solution containing about 33 oz per gal of chromic acid and 0.33 oz per gal of sulfuric acid at 130 F (55 C) and 400 amp per sq ft with a 3-in. electrode distance. Cathode current efficiencies are about 17.5% and metal is deposited at a rate of about 0.0014 in. per hr. However, by raising the operating temperature of this solution to 140–170 F (60–75 C) current densities as high as

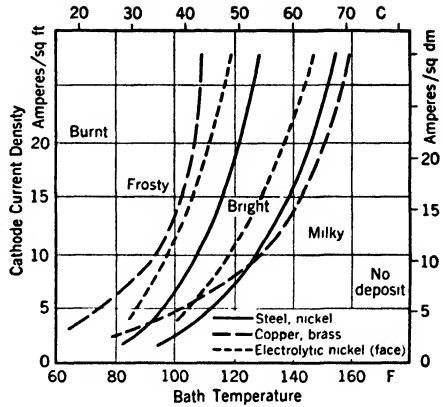


FIGURE 379. The effect of base metal, current density, and temperature on the character of electrodeposited chromium. (From Ref. 1 at the end of this chapter, courtesy Reinhold Publishing Corporation.)

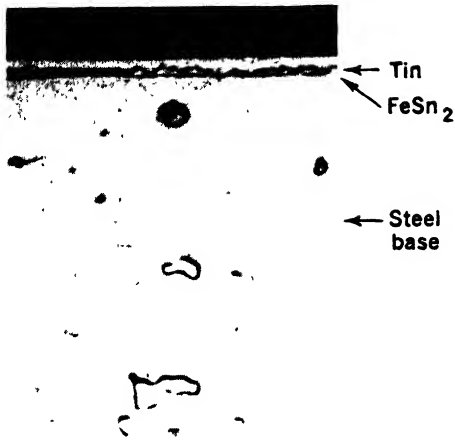


FIGURE 380. Metallographic structure of cross section of electrolytic tin plate that was subsequently melted. Average weight of coating 0.57 lb per base box. Double etched with nitric and hydrofluoric acids in amyl alcohol and with 5% picral to reveal FeSn<sub>2</sub> alloy layer.  $\times 2500$ . (Photomicrograph courtesy O. E. Romig.)

300–3000 amp per sq ft can be used and chromium can be deposited faster than 0.0025 in. per hr. This latter procedure has not found much commercial use, however, because if a piece of any appreciable area were plated the amperage required would heat the solution so much that external cooling would be required to maintain normal operating temperatures.

The biggest disadvantage of hard chromium deposits is the tendency of hydrogen to deposit simultaneously with the metal, causing it to be embrittled and to crack in use. This effect may be reduced by a heat-treatment of 300 F (150 C) for  $\frac{1}{2}$ –1 hr. after

plating. However, cracks still are apt to occur and are particularly undesirable when the coating is on a part, such as a shaft or spindle, exposed to cyclic stresses as they act as stress raisers and, as such, accelerate the formation of fatigue cracks.

#### TIN PLATING

One of the most significant developments of the war period in the field of protective coatings was the continuous electroplating of steel plate.<sup>9</sup> Only by this means was it possible to stretch out the tin stockpile, which we had at the start of the war, to a sufficient extent to permit the continued production of tin plate for canning foodstuffs and other essential purposes. Whereas a 1.25-lb coating of tin was about the minimum that could be satisfactorily applied by the conventional hot-dip process, electroplated plate with a 0.5-lb coating can be produced without difficulty. Furthermore, this thinner coating (Fig. 380) seems to meet the fundamental requirements for tin plate for all except a relatively few applications.

Using wooden equipment whenever possible, an electroplating line will run at a top speed of at least 500 ft per min and can turn out, roughly,  
<sup>9</sup> See, for example, M. D. Stone, *Iron & Steel Engr.*, 19, Feb. 1942, 90–96.

1,000,000 boxes per year when run for 20 turns a week of 8 hr each. Steel plate, in widths up to 36 in., is taken in coils from the cold-rolling mills, trimmed at the edges, cleaned and pickled, and electrolytically coated with tin. Depending upon the particular process being used the electrolyte may be *acid*, composed of stannous sulfate, sulfuric acid, and addition agents and operated at 65–110 F (18–43 C), or *alkaline*, consisting chiefly of sodium stannate and sodium hydroxide and operated at 150–180 F (66–82 C). The finished strip may be either rerolled in coil form or sheared into squares.

The alkaline bath has a somewhat higher throwing power and an appreciably lower cathode current efficiency than the acid bath. However, its resistance is also considerably greater than that of the acid bath so that, for the same number of kilowatt hours, it will deposit only about a tenth as much tin, or, conversely, its power cost will be about ten times that of the acid bath<sup>10</sup> if the same amount of metal is deposited. Under ordinary and comparable conditions the acid bath also will deposit tin from two to three times faster than the alkaline bath.

#### COMPOSITE AND HEAT-TREATED ELECTROPLATED COATINGS

In some instances superior corrosion resistance can be secured by depositing one or more coatings electrolytically, or by heating the plated parts to facilitate diffusion, either between the coatings themselves or between the coatings and the base metal.

In the first group are the *Corronized* coatings consisting of a layer of pure nickel followed by a layer of nickel-zinc ( $\gamma$  phase) alloy. Properly made, these coatings are ductile, adherent, and corrosion resistant and have given promising results in such applications as screen wire, fence wire, and motor parts.<sup>11</sup>

Likewise if indium is electroplated on silver and certain other alloys and given a suitable heat-treatment a corrosion-resistant surface layer is said to result.<sup>12</sup> This treatment has been used for certain aircraft bearings.

#### *Cementation*

The process of cementation is one of the oldest known for applying protective coatings although generally it was used to produce increased strength, hardness, and wear resistance rather than to impart corrosion re-

<sup>10</sup> See P. R. Pine on p. 315 of Ref. 2 at the end of this chapter.

<sup>11</sup> See R. Rimbach, *Metal Finishing*, 39, July 1941, 360–364.

<sup>12</sup> See M. T. Ludwick, *Metal Finishing*, 40, January 1942, 13–17; *Steel*, 111, Nov. 9, 1942, 80–81, 122–124.



sistance. The cementation of copper with zinc to give *calomel brass* and of iron with carbon to give *Damascus steel* are two of the earliest known metallurgical processes. Essentially, the process consists of heating the part to be cemented to an elevated temperature in contact with a solid, liquid, or gaseous medium containing the cementing material. Diffusion then will cause the cementing material to penetrate inward from the exposed surface, thus producing an alloy on the surface, the concentration decreasing as the distance inward from the surface increases. The surface alloy may result from the formation of a compound, of a solid solution, or from diffusion at the grain boundaries only.

For diffusion, a good contact is necessary; and, as a result, the presence of oxide films or similar hindrances to good contact will prevent penetration and restrict the formation of cemented coatings. The thickness and nature of the coating will depend upon the temperature, the time, and the nature and physical state of the metals involved. The concentration gradient depends on the type of coating and the conditions for its formation.<sup>13</sup>

Many of the alloys formed by *powder metallurgical methods* result from what are essentially cementation processes.<sup>14</sup> Certain of the metal powders will absorb, and alloy with by diffusion, the other constituents present. As mentioned above, the constituent to be absorbed may be either solid, liquid, or gaseous, the necessary sintering or heating time generally decreasing as the mobility of the cementing material increases.

#### TYPES OF CEMENTED COATINGS TO RESIST CORROSION

A very large number of elements are impregnated into iron and steel by the method of cementation. Some of these processes are listed below, alphabetically:

*Calorizing (Aluminizing)* is the production of a layer of aluminum 0.005–0.040 in. thick on iron, steel, copper, or brass by heating in a mixture of 5–50% powdered aluminum with aluminum oxide and ammonium chloride. The time required is 4–6 hr at 1600–1700 F (870–930 C). This frequently is followed by an additional homogenizing treatment of 12–48 hr at 1500–1800 F (820–980 C) in the absence of aluminum in order to increase the depth of penetration, and to decrease the aluminum content of the impregnated layer from about 60% aluminum to about 25% or less.

Calorized parts are used for salt, cyanide, and lead pots operated below 1550 F (840 C), for some high temperature bolts, for tubes for air heaters, and oil and gas polymerization, for exhaust pipes, and for furnace parts.

<sup>13</sup> A thorough review is given by F. N. Rhines, *Metal Treatment*, 9, 1942, 40–51.

<sup>14</sup> See, for example, the discussion of *sintering* by P. E. Wretblad and John Wulff, in *Powder Metallurgy*, pp. 36–59, A.S.M., Cleveland, Ohio, 1942.

The chief value of calorizing lies in preventing access of the air to the part being protected, and the principal disadvantage lies in the rather brittle alloy layer that tends to form between the aluminum and the iron.

*Chromizing*<sup>15</sup> consists of packing iron or low-carbon steel (0.10–0.20% carbon) in a mixture of 55% chromium powder or powdered ferrochrome and 45% (by weight) of alumina and heating, in an atmosphere of hydrogen, to temperatures of 1800–2600 F (980–1430 C) depending upon the thickness desired. Heating for 1 hr at 1850 F (1010 C) will give a casing 0.004–0.005 in. in depth, containing 10–20% chromium.

Chromizing has been used to protect turbine buckets against corrosion and erosion, and to protect any steel parts which have to withstand atmospheric corrosion or the attack of nitric acid. These coatings also tend to be brittle, however, so they have a restricted application.

*Sherardizing* is the application of zinc to iron and steel (or to non-ferrous metals) by heating at 650–700 F (340–370 C), in zinc powder or in commercial “blue powder” (85–90% metallic zinc with 5–8% ZnO) for a period of 3–12 hr. A coating of 0.5 oz per sq ft (approximately 0.001 in. thick) is produced by heating 2–3 hr at 700 F (370 C).

The principal application of sherardizing is for small steel parts such as bolts, nuts, and washers, or for castings that have to resist atmospheric action.

*Siliconizing (Ihrigizing)* produces a case, containing about 14% silicon, on steel, which is preferably low in carbon, by heating it in a mixture of silicon carbide, or ferrosilicon, and chlorine at temperatures of 1700–1850 F (930–1010 C). A case of 0.025–0.030 in. will be produced in about 2 hr. Ordinary case thicknesses can vary from 0.005–0.100 in. although the composition falls off somewhat after about 0.040 in. The case is rather brittle, with a hardness of Rockwell B80–85. It can be ground, but not machined or cut with a hacksaw by ordinary means. High-carbon, low-sulfur steels and low-sulfur cast irons also can be impregnated, but at a much slower rate.

Pieces thus treated have been used to resist corrosion, heat, and wear in applications such as automotive water-pump shafts, cylinder liners, valve guides, valve fittings, and similar parts for the chemical, paper, and oil industries. Some examples are illustrated in Fig. 381.

### *Metal Spraying*

Any metals which can be produced in the form of wire and which will fuse in the oxyhydrogen flame can be applied to almost any surface by

<sup>15</sup> See also C. M. Cosman, *Iron Age*, 150, Nov. 26, 1942, 49–52.

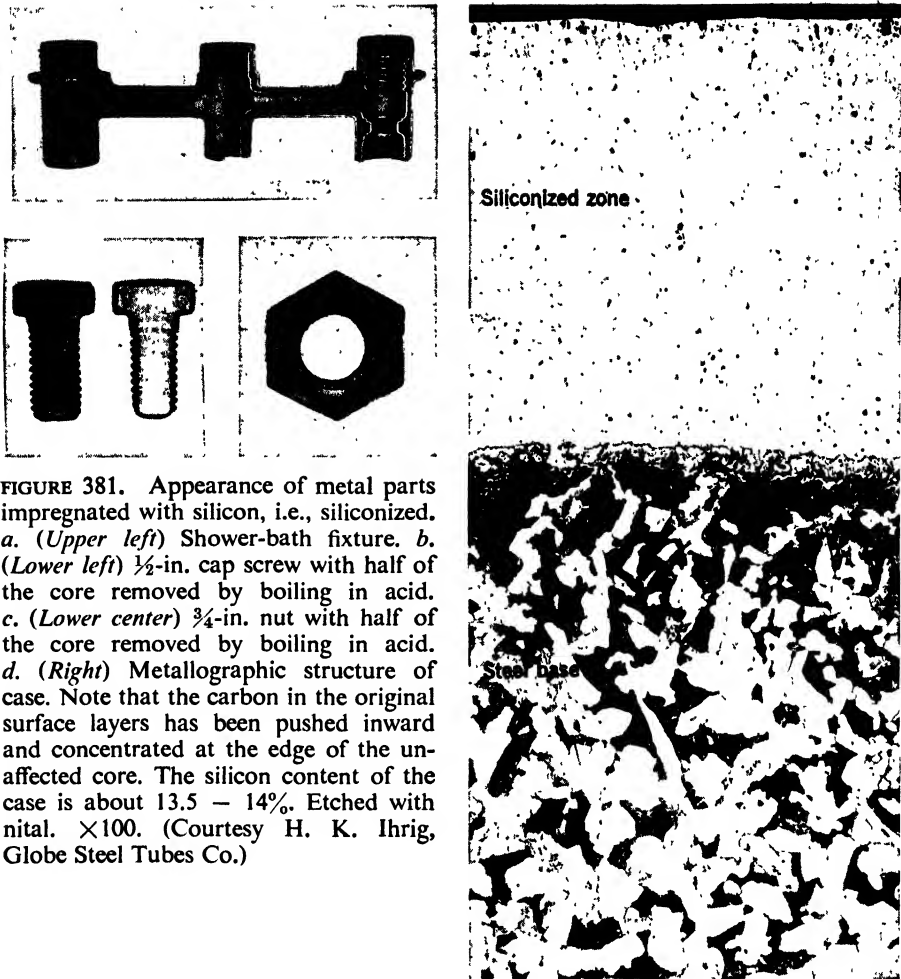


FIGURE 381. Appearance of metal parts impregnated with silicon, i.e., siliconized. *a.* (Upper left) Shower-bath fixture. *b.* (Lower left)  $\frac{1}{2}$ -in. cap screw with half of the core removed by boiling in acid. *c.* (Lower center)  $\frac{3}{4}$ -in. nut with half of the core removed by boiling in acid. *d.* (Right) Metallographic structure of case. Note that the carbon in the original surface layers has been pushed inward and concentrated at the edge of the unaffected core. The silicon content of the case is about 13.5 – 14%. Etched with nital.  $\times 100$ . (Courtesy H. K. Ihrig, Globe Steel Tubes Co.)

spraying. Electrically operated pistols also have been developed to use both the higher melting and the low melting materials for spraying. The essential features of a commercial metal spraying pistol are shown in Fig. 382. The metal wire is melted by a gas mixture and then atomized, cooled, and driven by an air blast at high velocity against the surface to be sprayed. Because of the rapid cooling of the blast the temperature 4–5 in. from the nozzle is fairly low. This permits the spraying of almost any conceivable material. Adherence is purely mechanical and no alloying occurs. The surface, therefore, must be prepared before it is sprayed. Knurling, rough turning, sandblasting, and pickling all are used depending on the base metal. The adherence is not great and is influenced by the relative coeffi-

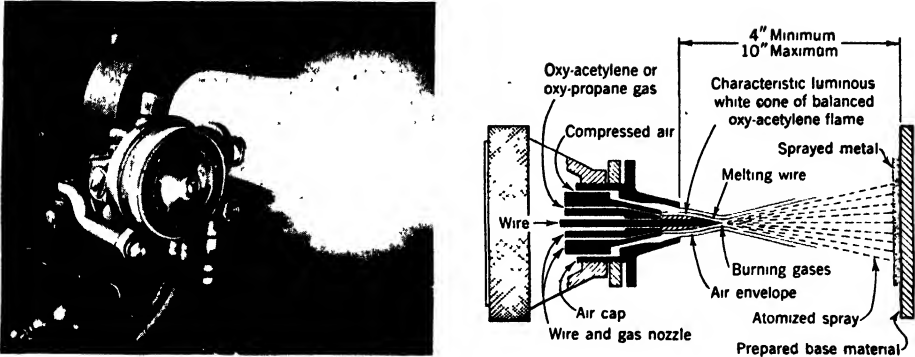


FIGURE 382. Close-up of METCO type 2E metallizing gun in operation spraying a machine part (*left*), with a diagrammatic cross section of the wire nozzle and cap (*right*). (Courtesy Metallizing Engineering Co., Inc.)

cients of thermal expansion of the coating and the base metal, especially for applications at elevated temperatures.

The method is applied principally to the spraying of large and extensive metal surfaces *in situ*, such as bridges, gas tanks, electrical transmission towers, hulls of ships, etc., and for building up worn shafts and similar parts. Both the thickness and the composition are controllable readily. The process also is used sometimes to repair defective coatings made by other processes.

### *Metal Cladding*

If two layers of metal are attached firmly, either by welding, silver brazing, casting, or by some other method, as illustrated in Fig. 383 for stainless-clad steel, they can be rolled or drawn subsequently to very thin gauges, retaining throughout approximately the same relative thicknesses. The bond between them, promoted by mutual interdiffusion, is very strong. Such coatings can increase corrosion resistance not only by their mechanical shielding, but also by chemical protection. Some of the more common examples, in addition to the stainless-clad steel already illustrated, are mentioned below:

*Alclad* products are made by casting an ingot of an aluminum alloy, usually one of high strength, into a steel mold lined either with pure aluminum or with an aluminum alloy which would be anodic to the metal being cast. Since the anodic coating will protect electrochemically as well as physically, some remarkable results have been secured by this method. In particular, the electrochemical protection extends to the exposed edges of the base metal, which is a definite advantage. The corrosion resistance of the sur-

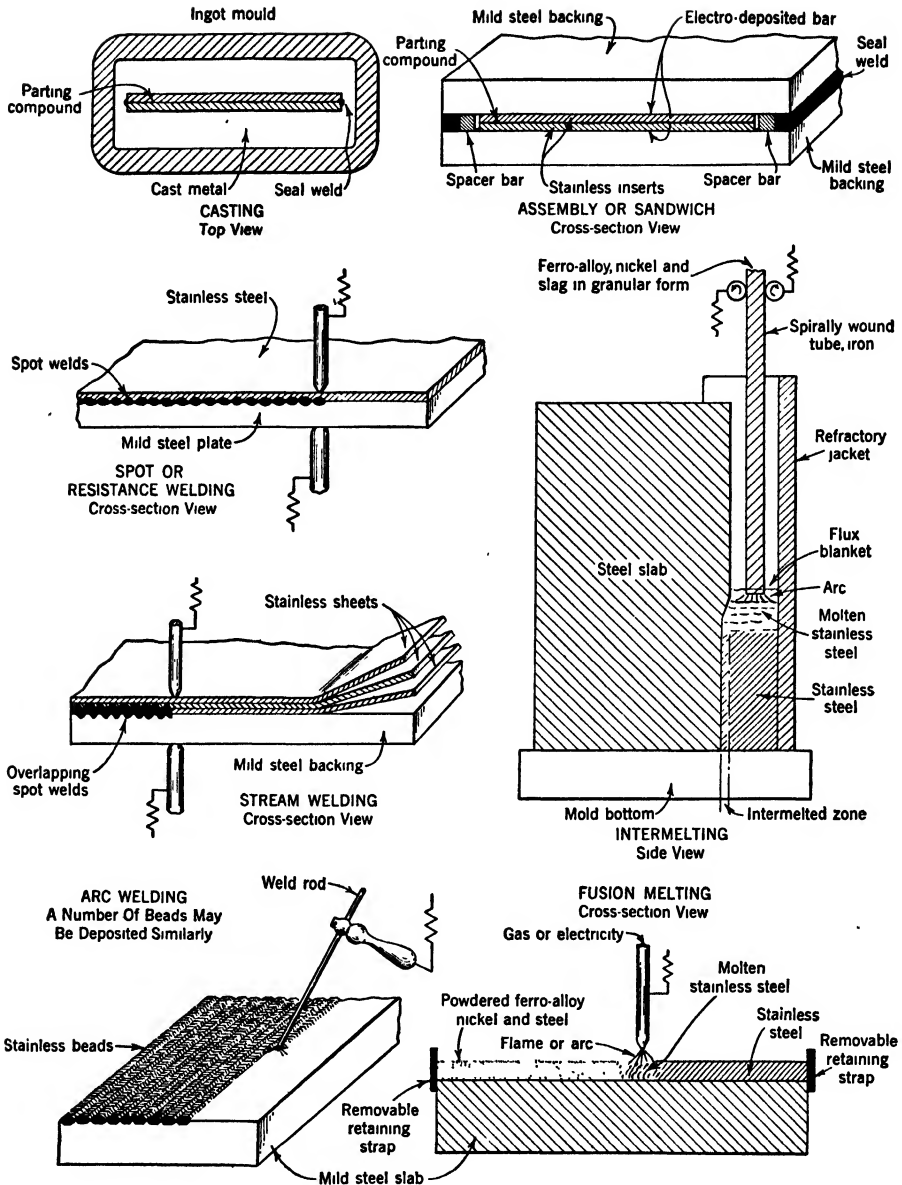


FIGURE 383. Seven commercial methods for making stainless-clad steel. (From *Industrial and Engineering Chemistry*.)

face layers admirably supplements the strength of the base metal, and the resulting product finds widespread use in the aircraft industry.

*Copper-clad* or *Copper-weld* steel is a similar product, but usually the copper is cast on or welded to a steel ingot rather than the reverse. Any of

several methods may be used for its preparation, but essentially the effect of all of them is to produce a composite billet having a steel center and a copper casing. This is rolled subsequently to the finished size with little or no change in the relative thickness of the coating. The copper, of course, gives only physical protection except where it is alloyed with the base metal.

“Copper-clad” steel also has been made by a somewhat different process designed to lessen the alloyed layer. A steel billet is electroplated with copper and then enclosed in a close-fitting cast-copper tube. By preventing the access of air to the junction surface a satisfactory weld can be produced by heating to about 1740 F (950 C) and then working to the desired shape.

*Nickel-, Monel-, and Inconel-clad* steel are made in a similar manner by rolling together heavy layers of steel and nickel or its alloys at temperatures of about 2200 F (1200 C), the bonding being possible on one or both sides of the steel sheet. In this case, also, the protection is only physical, and all exposed edges must be covered.

Products also are made in which steel is coated by silver, or karat gold; and brass, bronze, and nickel silver or similar copper- and nickel-base alloys are coated with thin layers of gold alloys by the processes of *gold rolling* and *gold filling*, producing structures similar to those illustrated in Fig. 384.

Many other similar processes are in various stages of development, and will undoubtedly become of commercial importance in the near future. This method of protection enables the use of a comparatively expensive corrosion-resisting alloy to protect a much cheaper higher strength alloy which has inferior corrosion resistance. By proper combination it is entirely feasible to secure composite metals which combine successfully both high strength and high corrosion resistance with a moderate cost.

### *Protective Film Formation*

— Certain metals form their own protective coatings when exposed to the atmosphere or other corroding media. Among these may be mentioned aluminum, which forms a thin, dense, tightly adherent coating of aluminum oxide, about 0.0000004 in. thick, and copper, which forms a coating either of copper oxide or, with time, of a characteristic green *patina* which is probably either a complex sulfate or carbonate of copper. Interestingly enough, sometimes these films will form even when the element is present only as a minor constituent of the alloy. In this respect may be mentioned, for example, the use of aluminum, silicon, or chromium in heat-resisting steels, and the use of silicon or aluminum in brass.

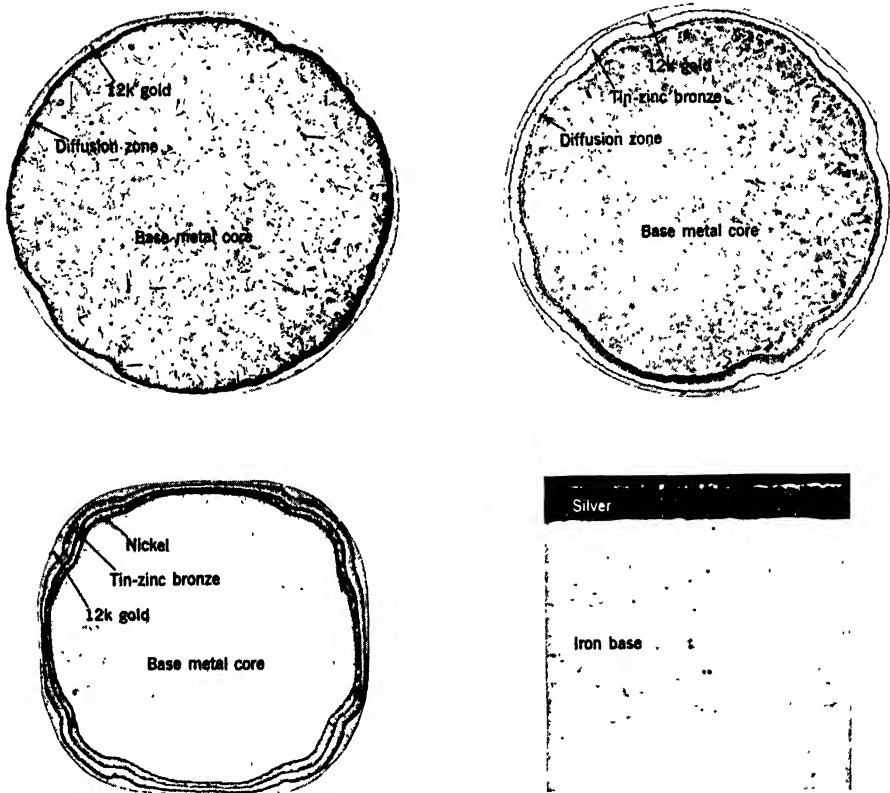


FIGURE 384. Typical structures of gold-filled and silver-clad metal.

*a.* (Upper left) "Single plate." A 12 K gold shell is silver brazed directly to a base metal core, and then rolled and drawn into wire. Cross section of wire 0.080 in. diameter. Etched with ammonium persulfate-potassium cyanide solution.  $\times 50$  originally; reduced about one half in reproduction.

*b.* (Upper right) "Double plate." A composite shell first is made by silver brazing together plates of 12 K gold and a base metal and rolling and deep drawing the assembly. This shell then is silver brazed to a base metal core, and rolled and drawn into wire. Cross section of wire 0.100 in. diameter. Etched with ammonium persulfate-potassium cyanide solution.  $\times 40$  originally; reduced about one half in reproduction.

*c.* (Lower left) "Double plate with an innerliner." A composite shell first is made by silver brazing together plates of 12 K gold, a copper-base alloy and nickel, and then rolling and deep drawing this assembly into a shell. This shell then is silver brazed to a base metal core and rolled and drawn into wire. Cross section of 0.080 in. "square" wire. Etched with ammonium persulfate-potassium cyanide solution.  $\times 40$  originally; reduced about one half in reproduction.

*d.* (Lower right) Silver-clad iron. Etched with nital.  $\times 50$ . (Photomicrographs by L. Litchfield.)

#### ARTIFICIALLY FORMED FILMS

Protective films can be and are produced artificially in many instances, either by chemical or by electrolytic methods. The artificially produced

coatings are frequently as much as 100 times as thick as those formed naturally.

Artificially formed films perhaps are used more widely for the protection of aluminum alloys than for any other group of materials. Several methods for forming films which are permanent or semipermanent in nature have been perfected for use with these materials. Protective coatings also are formed on steel objects by several different methods.

#### PROTECTIVE COATINGS ON ALUMINUM

The *Alumilite* finish is the result of the most practical of the anodizing treatments commonly used for aluminum and its alloys. In this process the piece being coated is made the anode in a bath containing sulfuric acid as the electrolyte. Depending upon the characteristics of the coating desired, acid strengths from 5–77% by weight may be used at temperatures of from 60–105 F (16–40 C). About 30 min in the bath usually is required to produce an oxide coating of the desired thickness. By proper treatment this coating can be produced plain, dyed, or colored with mineral pigments. For maximum corrosion resistance the coating must be sealed by immersion, either in a hot dichromate sealing solution, which gives a yellowish tinge, in steam or boiling water, or in sodium silicate or chromic acid solutions. Coatings formed by this process are generally 0.0001–0.001 in. thick.

Similar finishes also can be produced by anodizing aluminum and its alloys in a 3% chromic acid solution at 105–115 F (40–45 C); or, as in the *Eloxal* process, in dilute oxalic acid containing a small amount of chromic acid.

#### PROTECTIVE COATINGS ON STEEL

In *Coslettizing* and *Parkerizing* an iron phosphate coating is applied to iron or steel. The latter process, which is used commonly in this country, accomplishes this by an immersion in a manganese di-hydrogen phosphate solution for 30–60 min. The addition of a small percentage of a copper salt to the bath enables the time to be reduced to about 10 min, thereby permitting the process to be used in line conveyor systems. On this base, which is gray in color, paints or oils and waxes may be used to secure a black coating. Without these aids the coatings have little corrosion resistance. *Parkerizing* also is used on cast iron, and on zinc coatings and zinc-base die castings. In the latter case, *Parkerizing* followed by two coats of a baked synthetic resin enamel has improved corrosion resistance several-fold.



A modification of this process, in which spray coatings are applied in 30–60 sec at 180 F (80 C), using solutions of zinc phosphates containing alkali nitrates or nitrites is called *Bonderizing*. This is intended primarily as a base for paints and will give only temporary protection unless painting follows.

*Black oxide* coatings also can be produced on iron and steel articles, generally by immersion in molten salts at temperatures of 250–300 F (125–150 C). Several different salt mixtures are available commercially under a wide variety of trade names, but basically they are all concentrated solutions of caustic soda containing an appropriate oxidizing agent. The black oxide coatings also must be treated with oils or wax if they are to have any real corrosion resistance.

#### PROTECTIVE COATINGS ON OTHER METALS

Similar treatments<sup>16</sup> with phosphates, chromic acid, dichromate, or strong alkali solutions are given to magnesium alloys and to zinc alloys<sup>17</sup> as preparation for painting. Sometimes these are spray, sometimes dip, and sometimes electrolytic coatings.

Black oxide coatings of various types also can be applied to many non-ferrous alloys by immersing them at elevated temperatures in molten salt mixtures of the proper composition.

#### PASSIVATION

An effect similar to that produced by the protective films and coatings and sometimes, perhaps correctly, confused with it is the phenomenon of passivity to which many metals are subject.

Passivation probably results from the formation of a very thin, almost monomolecular film of oxide or of oxygen on the surface of the metal affected. It is produced by immersion in certain liquids, usually alkalies or strong oxidizing agents, the exact nature of which depends upon the metal. As a rule, however, the effect is not permanent unless the metal is kept in contact with the passivating agents. Thus, the introduction of sodium dichromate crystals into an automobile radiator ( $\frac{2}{3}$  oz per gal of water) will inhibit rusting.

However, since the effect of passivation is to render the affected section cathodic to an active piece of the same metal, localized corrosion may be markedly accelerated, if the passivation is imperfect, because of the galvanic action which would result.

<sup>16</sup> A complete discussion is given by J. B. Edwards, *Metal Industry, London*, 61, Aug. 1942, 103–105, 119–120.

<sup>17</sup> The *Cronak* and *Iridite* finishes are commercial types.

## *Painting*

Paints,<sup>18</sup> despite the fact that their protection is purely mechanical, are still one of the most widely used protective coatings. Paints protect metals by means of the interposition of a continuous, inert, and adherent film between the surface of the metal and its environment. In addition, they enable a complete alteration of the surface appearance of the metal with regard to color, surface texture, and gloss. Classes of coverings in this group include:

1. *Paints*,<sup>19</sup> which are dispersions of pigments or combinations of pigments in a drying oil. The drying oil is converted to a gel state usually by virtue of oxidation at normal temperatures. Drying is relatively slow and the films are soft and readily deformable, hardening progressively with a definite reduction in distensibility. Paints largely are used for coating large fixed structures where the coating is applied after erection or at the location of the structure.
2. *Enamels*,<sup>20</sup> which are intimate dispersions of pigments in a varnish or resin vehicle. These may "dry," i.e., be converted into the gel state, by oxidation, either at room temperature or at an elevated temperature. This can take place in the absence as well as in the presence of oxygen. Enamels usually are applied to a structure which can be moved to the point of application of the finishing material. The pigment dispersion is greater than in paints and the gloss is higher so they are more decorative. They also resist mechanical abuse quite well.
3. *Lacquer enamels*,<sup>21</sup> which are dispersions of pigments in a lacquer vehicle. In this case, "drying" is accomplished by the volatilization of the solvents. Because of their greater drying speeds, lacquer enamels are used extensively for the protection and decoration of almost any equipment for which spraying or dipping is feasible. Brush application of lacquers is not satisfactory, especially where more than one coat is used. Clear lacquers are used to protect polished metal surfaces from tarnishing. However, they will not, as a rule, stand water, especially when it is warm or soapy.
4. *Priming coats* are made by dispersing certain pigments in a paint vehicle. They have found extensive use even though they may not be entirely satisfactory for top coats for a variety of reasons. In such cases the electrochemical action is much more important than the physical protection, and further protection by means of top coats almost al-

<sup>18</sup> This general subject is discussed well by R. J. McKay and R. Worthington, Ref. 6 at the end of this chapter.

<sup>19</sup> See A.S.T.M. *Symposium on Paint and Paint Materials*, 1935.

<sup>20</sup> See also *Lacquer and Synthetic Enamel Finishes*, by R. C. Martin: D. Van Nostrand Company, Inc., New York, 1940.

<sup>21</sup> See R. C. Martin, *loc. cit.*

ways is required. In this group would be included red lead, zinc and basic lead chromates, iron oxides, aluminum, and graphite.

5. *Bituminous materials*, such as asphaltic and pitch coatings, are used extensively for protection against soil corrosion in pipe lines, etc. They are characterized by a low tensile strength and a relatively high plastic extension.<sup>22</sup>

### *Vitreous Enameling*

*Vitreous* or *porcelain enamels* are essentially fused silicates or glasses holding in suspension a colloidal dispersion of color oxides, opacifiers, and gases.<sup>23</sup> They are used widely in the chemical, pharmaceutical, and food industries, and will resist practically any chemicals except those which will attack silicates. These coatings are fired or burned on, by first drying and then heating to a temperature of approximately 1450–1600 F (790–870 C) for a period of 1–5 min for light ware, and for longer periods for heavy ware. A cast-iron base requires a lower temperature and a longer time. Each coating is fired separately, and usually cooled to room temperature before the next coat is applied. Generally, the composition of the steel used must be carefully controlled, and it must be free from strains and carefully cleaned before use.

### *For Further Study Refer to*

1. *Protective Coatings for Metals*, by R. M. Burns and A. E. Schuh: Reinhold Publishing Corporation, New York, 1939.
2. *Modern Electroplating*: Electrochemical Society, New York, 1942.
3. *Principles of Electroplating and Electroforming*, by W. Blum and G. A. Hogaboom: McGraw-Hill Book Company, Inc., New York, 1924.
4. *Protective Metallic Coatings*, by H. S. Rawdon: The Chemical Catalog Company, Inc., New York, 1928.
5. *Plating and Finishing Guidebook*: Metal Industry, New York (published annually).
6. *Corrosion Resistance of Metals and Alloys*, by R. J. McKay and R. Worthington: Reinhold Publishing Corporation, New York, 1936.

<sup>22</sup> For a further discussion see A. L. Raphael and A. Holmes, *Protective and Decorative Coatings*, Vol. I, Chap. 28, p. 739, edited by J. J. Mattiello: John Wiley & Sons, Inc., New York, 1941.

<sup>23</sup> For a thorough discussion see *A Manual of Porcelain Enameling*, edited by J. E. Hansen: The Enamelist Publishing Co., Cleveland, Ohio, 1937.

## XIII

# Alloys Used Largely Because of Ease of Fabrication

### CLASSIFICATION

**T**HE METALS AND ALLOYS USED LARGELY BECAUSE OF EASE OF fabrication are required, mainly, to resist only atmospheric corrosion, and are not considered as a rule to have a particularly high corrosion resistance. For many applications, some sort of protective coating must be used to make the material entirely satisfactory. Cost and appearance are frequently the controlling factors in their selection, and they seldom are used because of their mechanical properties alone since they usually are not expected to bear any appreciable load other than their own weight.

Two types of alloys will be considered, the classification depending upon the form in which they are utilized predominantly. The first of these includes the wrought materials which are used, largely in sheet form, either for roofing, sheathing, or siding, or for ornamental and deep-drawing purposes; and the second includes those items classed as hardware which are fabricated largely by casting, die casting, or hot or cold extrusion, and in which free-machining characteristics frequently are desirable.

### *Commercial Wrought Alloys*

#### REQUIREMENTS FOR WROUGHT MATERIALS

In the wrought materials of this group strength alone is relatively unimportant and emphasis is placed predominantly upon workability. Stiffness and rigidity, when necessary, are taken care of by the design and assembly. *Corrugation* is a common method of doing this.

Resistance to sag under atmospheric conditions is of some importance, especially if the material is to be used unsupported. Formability in the finished product is essential to easy assembly, and some relatively simple method of joining, such as soldering, also is desirable for the same reason.

The character of the surface in the finished articles, especially those made by deep drawing, is usually important, and almost invariably this requires properly heat-treated metal that is both sound and clean. In addition, each lot of metal should be uniform and consistent, in that it should duplicate previous lots in so far as possible. In extreme cases this may necessitate the use of a specification grade material. A pleasing appearance generally is desirable. However, this may be produced either in the metal itself or in easily applied coatings or finishes.

A low cost is always preferable, but it must be emphasized that cost is generally a composite of the two factors, labor and material. Consequently, for a given application a more expensive material which requires fewer replacements can quite possibly be less expensive, over a period of time, than a cheaper one which must be replaced frequently. The economics of each application, naturally, must be decided upon their own merits because the conditions in each case generally are different.

Because of price considerations many of the requirements for this class of material are filled by ingot iron or low-carbon steel, usually galvanized or terne-coated. Copper, either in rolled or electrodeposited sheets and frequently tin- or lead-coated, and the wrought copper-zinc alloys, known as *brasses*, also are used widely for specific purposes. Less widely used are certain alloys of zinc, of aluminum, and of magnesium, and some of the stainless steels which run appreciably higher in cost. Lead and its alloys which were at one time prevalent, especially for roofing and similar purposes, are at present in disrepute largely because of their weight and general lack of rigidity. The advantages of lead are utilized by coating it on lighter materials.

The corrosion resistance of this group covers a wide range. Although many of the alloys are used unprotected, it usually is found desirable to protect them in some manner, if only to avoid the formation of an unsightly corrosion product.

#### INGOT IRON

American ingot iron is guaranteed to contain less than 0.16% total impurity and usually runs much less. A typical analysis of "Armco" iron, a trade-marked product of the American Rolling Mills Company and probably the best known of the commercial ingot irons, will show the following impurities:

0.012%	C
0.017%	Mn
0.005%	P
0.025%	S
trace	Si

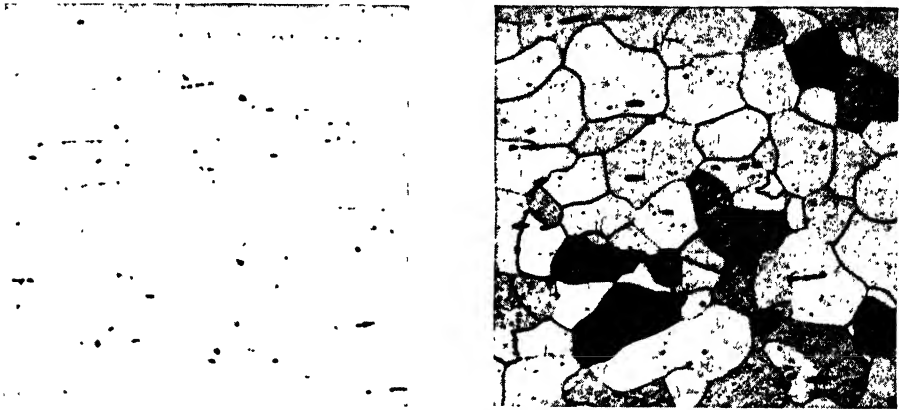


FIGURE 385. Metallographic structures of American ingot iron showing inclusions of iron oxide in a ferritic matrix. (*Left*) Unetched. (*Right*) Etched with nital.  $\times 100$ . See Fig. 142 also.

In addition, ingot iron will contain appreciable amounts of oxygen and some nitrogen as mentioned previously. However, oxygen and nitrogen usually are not considered as impurities in these commercially pure irons. Several similar alloys, of approximately the same carbon content but containing small amounts of various alloying elements, are available commercially.

In practically every case, the added alloying elements are in solid solution in the ferrite, and hence the structure of ingot iron shown in Fig. 385 will be typical of any of them although some difference in grain size naturally would be anticipated both because of differences in heat-treatment or hot-rolling temperatures and of the effects of the alloying elements. In general, all of these alloys also will have similar mechanical properties, approximating:

Tensile strength, psi	40,000–45,000
Yield strength, psi	25,000–30,000
Elongation, % in 2 in.	40
Reduction in area, %	50
Brinell hardness (10 mm–500 kg)	85

The strengths and hardnesses may run somewhat higher, and the elongations and reductions in area somewhat lower for the mild alloy irons than for unalloyed ingot iron.

Alloys of this type most generally are galvanized or tin coated by the hot-dip method in order to increase their corrosion resistance although bothterne and lead coatings are used also and large tonnages are electrotinned.

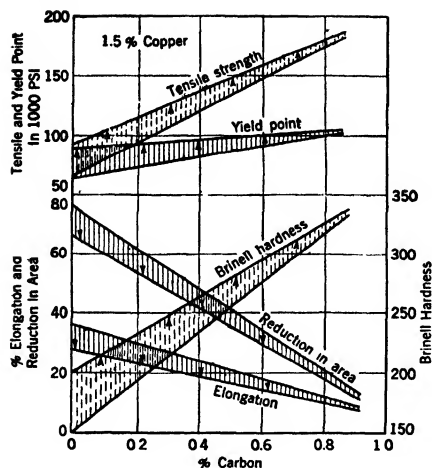


FIGURE 386. The changes in properties, after precipitation hardening, of normalized carbon steels containing 1.5% copper. The width of the bands and the direction of the arrows represent the maximum changes in properties on precipitation hardening and the direction which these changes take with respect to the properties of normalized steels. (Courtesy C. H. Lorig.)

on plain carbon steels. However, when subjected to submerged or to soil corrosion copper seems to impart no particular advantage.

Among the commercially available irons and mild steels of this type are: *Keystone Copper Steel*, *U.S.S. Copper Steel*, *Beth-Cu-Loy*, *Toncan Iron*, *Cop-R-Loy*, and *Copper Ingot Iron*.

Copper steels containing more than 0.6% copper are subject also to precipitation hardening although this effect is most pronounced in the range 1.2–1.5% copper.<sup>2</sup> The changes in properties to be expected in a normalized 1.5% copper steel after precipitation hardening are illustrated in Fig. 386. The increase in strength and hardness is seen to be much less in the high-carbon than in the low-carbon steels. It is notable that, with these alloys, the “quench” preceding precipitation hardening does not have to be drastic. In low-carbon steels almost any rate of cooling faster than a furnace cool will be entirely adequate. Precipitation hardening then is obtained by heating from 3–20 hr at 840–930 F (450–500 C), the longer times at the lower temperatures.

<sup>1</sup> V. V. Kendall and E. S. Taylerson, *Proc. A.S.T.M.*, **29**, II, 1929, 204–219.

<sup>2</sup> This subject is discussed at length in *The Alloys of Iron and Copper*, by J. L. Gregg and B. N. Daniloff: McGraw-Hill Book Company, Inc., New York, N. Y., 1934; and, more briefly, by C. H. Lorig in Ref. 1 at the end of this chapter, 1939 ed., 554–560.

In the galvanized form they are covered by A.S.T.M. Standard A93 for zinc-coated iron or steel sheets.

#### COPPER-BEARING IRON AND STEEL

For resisting the effects of atmospheric corrosion the tests which have been run by the A.S.T.M.<sup>1</sup> in industrial, rural, and marine atmospheres have shown that the resistance of steel to atmospheric corrosion is benefited by the addition of copper. Corrosion resistance increases most rapidly with additions of up to 0.25% copper and more slowly thereafter. For this reason copper usually is found in most of the mild alloy constructional steels. Painted and galvanized surfaces also appear to be more durable on copper-bearing than

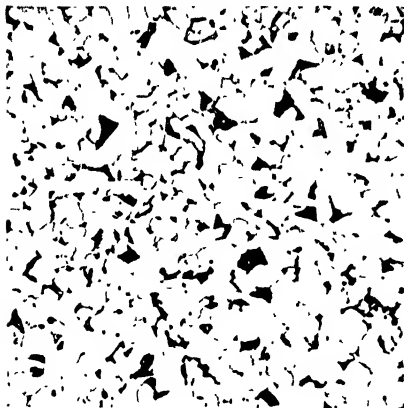
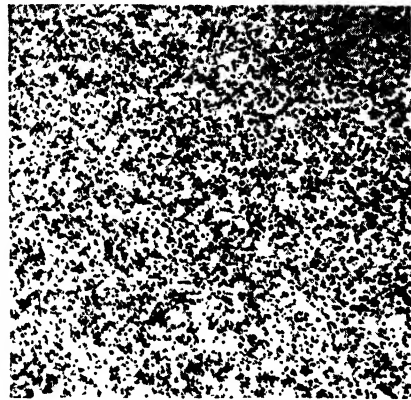
*a**b*

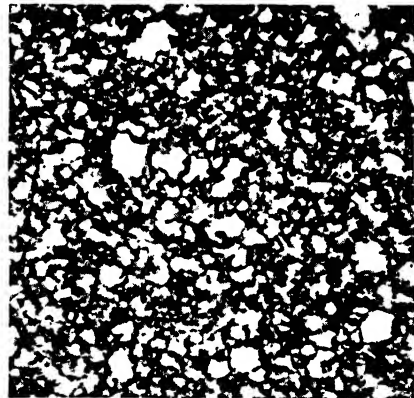
FIGURE 387. Metallographic structures of mild steel (0.10–0.15% carbon). Etched with nital,  $\times 100$ .

*a.* Normalized, showing pearlitic carbides in a ferritic matrix.

*b.* Process annealed, showing spheroidized carbides in a ferritic matrix. Rockwell hardness = 41–44 B.

*c.* Water quenched from above  $A_3$ , showing martensitic regions at the ferritic grain boundaries. Rockwell hardness = 100–106 B.

(Photomicrographs by L. Litchfield.)

*c*

#### MILD STEEL

Mild steel, containing less than 0.15% carbon, is somewhat similar in properties to commercially pure ingot iron, but usually is cheaper because it can be made more easily. This may be either Bessemer or basic open-hearth steel, but it is seldom a specification grade material when used for these purposes. The corrosion resistance of this alloy will not be quite so good as that of irons low in carbon because of the presence of a small amount of pearlite or of spheroidized iron carbide (Fig. 387) in the microstructure. The form in which the cementite appears will depend upon the previous treatment. This added constituent tends to accelerate the corrosion rate electrochemically, and thus decreases the resistance of the ferrite to rusting. The mechanical properties will be similar to and the strengths probably will be higher than those of the ingot irons. Although the treatment might never be encountered commercially, Fig. 387 also illustrates the



type of martensitic structure produced by quenching these mild steels. The increase in hardness possible by this means is appreciable.

Both tinning and galvanizing are used for protective coatings on mild steel, and much of it is terne- and lead-coated. Galvanized steel sheets also are covered by A.S.T.M. Standard A93.

The low-carbon irons and steels are used widely for agricultural implements, automobile accessories, building and construction hardware, trim and other fabricated sections, electrical equipment, enameled articles, furniture, stoves, machinery parts, metal containers, pressed and formed articles, signs, toys and novelties, ventilating ducts, etc.

In the form of wire they also are used extensively for wire fencing, especially after galvanizing. Although hot-dip galvanizing still is used for wire the trend seems to be toward continuous electrogalvanized coatings. Because of the absence of any alloy layer in electrogalvanized wire its formability frequently will be superior to that of the hot-dipped variety.

A.S.T.M. Standards covering galvanized iron or steel wire are:

A116: Farm-Field and Railroad Right-of-Way Wire Fencing

A117: Chain-Link Fence Fabric Galvanized after Weaving

A121: Barbed Wire

A111: Telephone and Telegraph Line Wire

A112: Tie Wires

Some sections of A122 and A218 for Wire Strand (Cable) also cover this class of material.

#### S.A.E. 1010 STEEL

When forming operations are severe much more care must be taken in manufacture and fabrication than when the steel is intended only for general usage. This often necessitates the use of steel of specification grade. Mild carbon steels used for such purposes as automobile body and fender stock and similar severe drawing operations, therefore, are usually of the S.A.E. 1010 or similar type. The S.A.E. specification calls for:

0.05—0.15% C  
0.30—0.60% Mn  
0.045% P (max)  
0.055% S (max)

Most steels of this type are made by the basic open-hearth process for which the specification allows 0.15–0.30% silicon.

The metallographic structures of S.A.E. 1010 steels will be similar to those of the nonspecification grades shown in Fig. 387. In the normalized

condition the structure will be composed of ferrite with about 10% pearlite occurring in small regions found largely at the junctions of several ferritic grain boundaries (cf. Fig. 223). In the unetched condition, of course, nothing would be visible except possible inclusions. After a series of cold-working operations and process anneals below the critical, however, the pearlite will be broken up and spheroidized cementite will be found instead.

The mechanical properties of such an alloy would depend largely on the reduction by cold-working, or the type of heat-treatment given and the grain size produced. An appendix to A.S.T.M. Standard A109 for Cold Rolled Strip Steel gives the approximate mechanical properties, usually for 0.050 in. thick strips, listed in Table XVIII.

TABLE XVIII APPROXIMATE MECHANICAL PROPERTIES OF VARIOUS TEMPER OF STRIP STEEL

TEMPER GRADE	ROCKWELL B HARDNESS (1/16-100-B)	TENSILE STRENGTH, PSI	ELONGATION, % IN 2 IN.
No. 1, Hard	84-96	68,000-92,000	1- 5
No. 2, Half-hard	75-85	56,000-72,000	4-14
No. 3, Quarter-hard	64-74	48,000-60,000	13-27
No. 4, Soft or planished	52-64	43,000-53,000	24-36
No. 5, Dead soft	38-52	40,000-48,000	33-45

The dead-soft temper material will tend to give stretcher strains but the planished material should be free from this defect as mentioned previously. The softer the material the deeper the draw it will stand. However, if the softness is produced at the sacrifice of small grain size the surface will be considerably roughened in the characteristic *orange-peel* pattern (cf. Fig. 58).

Deep-drawn articles of all kinds, automobile body and fender stock, galvanized sheet, tin plate, and sheet for vitreous enameling are various products made of this general type of material.

Specification grade steels usually command some premium in price over ordinary mild steel. However, because of the heavy tonnages involved, companies making these materials hold to the specifications rigidly, and attempt to keep the various impurities as low as possible without materially increasing the cost. For each particular application and process the most suitable analysis and treatment must be adhered to if uniform products are to result. Different consumers sometimes order to their own specifications

using limits other than those given above. Usually this can be done only by contracting for a large tonnage of metal, or by paying a higher price.

Material of this analysis is being made today largely on continuous rolling mills, both hot and cold, although a certain amount still is made on hand mills. Cold-rolling is employed to obtain the desired surface finish, to impart necessary physical properties, and to produce the thinner gauges which the hot mills cannot handle economically. Rimmed steel is used for many of the sheet and strip applications because of its softness and ductility and also because of its clean surface which tends to give a better appearance to the formed part. However, for deep draws, viz., greater than 35%, the percentage of failures because of surface imperfections is apt to be high with rimmed steel, and hence killed steels are being used more and more widely for such purposes.

#### AGING

The biggest disadvantages of rimmed steel, other than those already mentioned, are that it is apt to run less uniform in analysis, and that it will have a tendency to age.<sup>3</sup> This is the name given to a spontaneous change in properties which occurs in some steels at atmospheric or moderately elevated temperatures after a final heat-treatment or a final cold-working operation. It is probably a process similar to that occurring in the aging of Duralumin, which has been discussed previously, but whether it is the result of a precipitation of iron carbide, iron oxide or iron nitride is not as yet certain and probably depends on the type of aging. The principal effects of aging are to increase the hardness and strength of the material and to decrease its ductility and impact resistance. Even if these changes are relatively small they are likely to be of serious consequence if the alloy is to be deep drawn or otherwise worked severely, as both the breakage and the frequency of surface defects during fabrication will be increased.

Aging seems to be different if it occurs after a final heat-treatment (*quench aging*) than after a final cold-working operation (*strain aging*). The change of hardness on quench aging (Fig. 248*b*) is, in general, somewhat greater than on strain aging, although the degree and type of straining influence this to some extent. Quench aging lowers the impact resistance, but seldom results in actual brittleness, whereas strain aging may result in a brittle fracture. In practice the effects of strain aging are probably of much more importance than those of quench aging because the final operation given to nearly all strip and sheet steel for drawing and stamping is a light

<sup>3</sup> See, for example, E. S. Davenport and E. C. Bain, *Trans. A.S.M.*, 23, 1935, 1047-1056; E. Epstein and H. L. Miller, Ref. 1 at the end of this chapter 1939 ed., 602-611.

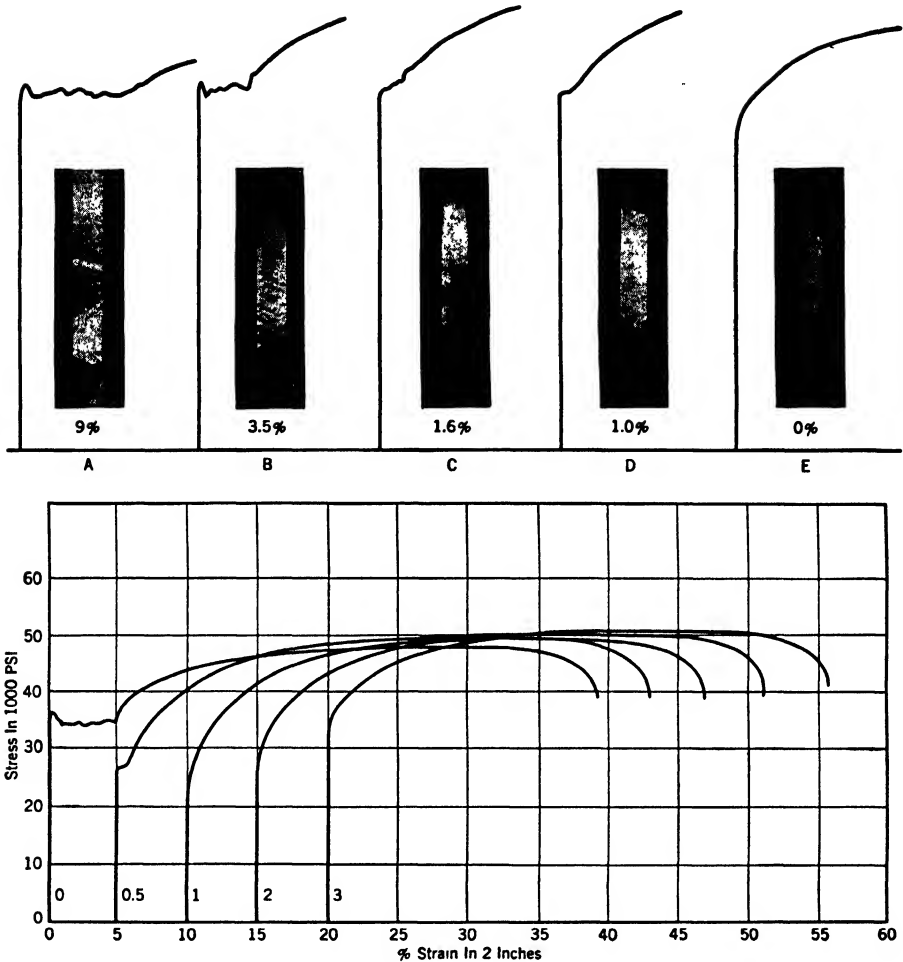


FIGURE 388 a. (Upper) Five stress-strain curves showing different amounts of elongation at yield point, together with photographs of the corresponding tensile specimens. Yield point elongations are indicated in each instance, higher values indicating a greater tendency to produce stretcher strains, as shown in the photographs. (Courtesy Research Laboratories, The American Rolling Mill Company.)

b. (Lower) Stress-strain curves of normalized, box-annealed, mild steel sheets, temper cold-rolled 0, 0.5, 1, 2, and 3% and tested fresh. Note absence of marked yield point in materials subjected to about 1% or more cold reduction. (Courtesy Research Laboratories, The American Rolling Mill Company.)

“skin pass” or temper rolling which, of course, leaves the steel in an ideal condition for strain aging. In some deep-drawing sheet this skin pass may be only a roller leveling within 24 hr of the final drawing operation. This planishing treatment is necessary because low-carbon steels in the soft annealed condition are among the few materials that display a true yield point at

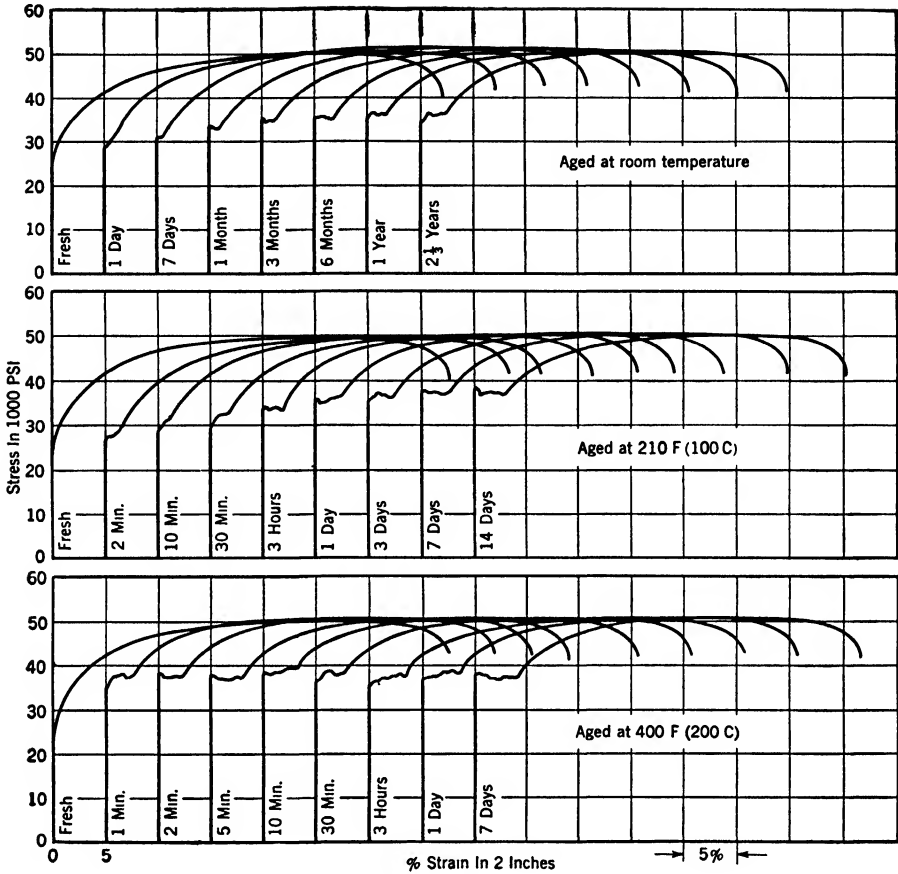


FIGURE 389. Stress-strain curves of mild steel sheets, temper cold-rolled 1% and aged for the indicated times at three different temperatures, showing the more rapid return of the yield point at higher aging temperatures. (Courtesy Research Laboratories, The American Rolling Mill Company.)

which the metal deforms very rapidly under a constant or decreasing load. This would be shown by a stress-strain curve having a high yield point elongation similar to *A* or *B* in Fig. 388*a*. When material with this characteristic is deep drawn it is susceptible to the defect known as *stretcher strains* or “Lueder’s lines,” which has been mentioned previously. The roughened surface produced by the metal thinning in this way cannot be hidden by paint and hence material so affected is usually a total loss. The final temper pass through the rolls will decrease this tendency since metal so treated will have a stress-strain curve similar to those in *D* and *E*, Fig. 388*a*, depending on the reduction used. This effect of reduction by temper cold-rolling is also illustrated by the curves in Fig. 388*b*. However, on standing for vary-

ing times after this rolling treatment, the yield point tendency will return, as illustrated in Fig. 389, the rate of return being more rapid at an elevated than at room temperature. Because of this, the storage, for any period of time, of sheets to be drawn or stamped is undesirable unless they are given another temper pass or are roller leveled within 24 hr of the final drawing operation.

In fully deoxidized (killed) *nonaging steel*, this strain-aging effect does not occur because dissolved oxygen and nitrogen are at a minimum.<sup>4</sup> The *Izett* steels are of this type.

Any tendency toward quench aging can, of course, be eliminated by slow cooling following the final heat-treatment in order to hasten the approach to equilibrium.

Aging begins immediately after the final cold-work or heat-treatment, but it usually is not serious until after 3 or 4 weeks. Its harmful effects are not the result of any marked change in properties but rather of the fact that, for reasons of economy, sheets for deep drawing are stressed so nearly to their breaking point that even relatively slight changes in their properties may cause a sizable increase in breakage loss and thus render the material entirely unsuitable.

#### ANNEALING FOR MAXIMUM DUCTILITY

It is well known that, in most metals, maximum ductility is secured with a small grain size. In steel, the shape of these grains also is significant. Carbon acts as a deterrent to grain growth in many cases, and this is one of the reasons for keeping the carbon above 0.03%. Since these low-carbon steels, that are predominantly ferrite, are susceptible to grain coarsening under proper circumstances both below and above the  $A_3$  critical, great care must be taken during the heat-treatment if the grain size is to be kept small. If the material has been finished by a cold reduction in excess of 30% it will soften if heated to a temperature in the range 1000–1400 F (550–750 C) as indicated in Fig. 67. In general, the lower the temperature, provided recrystallization occurs, the smaller will be the grain size. However, it is important to have the material both completely recrystallized and as uniform as possible. Both *bright annealing* in a nonoxidizing atmosphere and *box annealing* frequently are used to achieve this without excessive surface oxidation.

A normalizing treatment, given by heating above  $A_3$  (1650 F), also will

<sup>4</sup> See, for example, A. Hayes and R. O. Griffis, *Metals and Alloys*, 5, 1934, 110–112; and, for a somewhat different viewpoint, J. R. Low, Jr. and M. Gensamer, *Metals Technology*, T. P. 1644, December, 1943.

cause softening and recrystallization. With this treatment, the ferritic grain size and hardness will be subject to some control by the soaking time above  $A_3$  and the rate of cooling through the temperature range in which austenite is transforming to ferrite. A stress-relief anneal in the range 950–1200 F (500–650 C) sometimes is given to relieve the strains caused by rapid cooling after normalizing. Rapid cooling sometimes is used since it assists in securing a fine ferritic grain size. This stress-relief anneal produces essentially no change in structure but does cause some softening and decrease in strength.

The use of the normalizing heat-treatment with mild steel sheet is especially important, although it is not always used, for applications in which a uniform material is desired, such as in deep-drawing blanks for shell cases. Under certain conditions deep drawing results in an uneven or scalloped top on the shell formed. This is caused by a preferred orientation of the individual grains of the metal used, resulting in different properties in different directions in the rolled sheet. The normalizing treatment seems to eliminate these differences quite satisfactorily, and to give a statistically uniform material.<sup>5</sup> Process annealing does not always do this.

Mechanical properties are, unfortunately, not too good a criterion of how well a given steel will draw. The draw itself, or the manner in which it is made, is frequently much more significant.

#### THE ERICHSEN AND OLSEN DUCTILITY TESTERS

A certain measure of the ability of a metal to draw and the general appearance of its surface after drawing to various depths can be secured by applying either the Erichsen or the Olsen cupping test. These two tests are very similar and essentially consist of clamping a piece of metal between two flat faces and then forcing a round-headed steel ball or punch through the piece until fracture occurs. The gauge and depth of the cup, which the Erichsen machine measures in millimeters and the Olsen test measures in thousandths of an inch, and the character of the surface are both important in judging the formability of the material. Under certain conditions the location and type of fracture when the test is carried to breaking also may give worth-while information. The general principles of the two tests are illustrated in Fig. 390.

The Erichsen and the Olsen tests are used in both the ferrous and non-ferrous industries although the methods of application and interpretation may vary.

<sup>5</sup> See, for example, Arthur Phillips and H. H. Dunkle, *Trans. A.S.M.*, 23, 1935, 398–405.

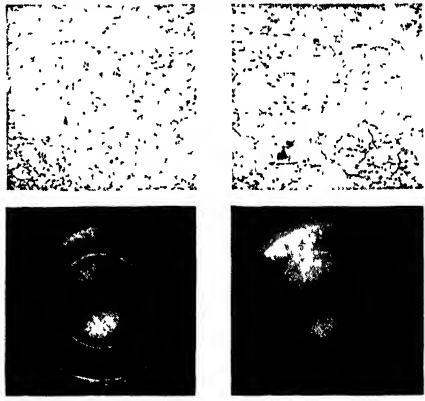
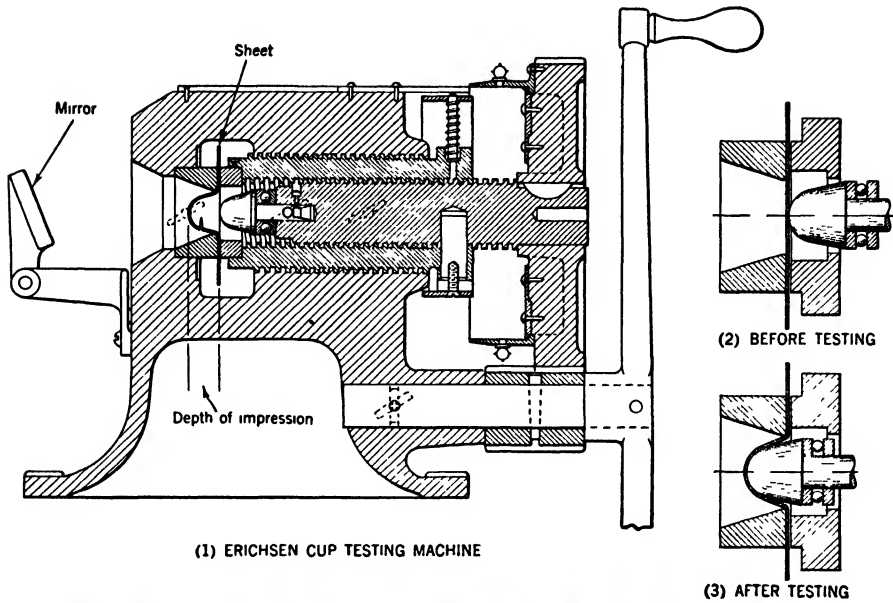


FIGURE 390. Two common types of cupping tests used on sheet metal to determine grain size and ductility.

(Upper) The Erichsen test, most commonly used on nonferrous metals, with examples of cups made in high brass sheet. The grain size becomes coarser successively from left to right. (Courtesy the Bock Machine Co., and the American Brass Company.)  
 (Lower) The Olsen test, most commonly used on ferrous metals, with examples of cups made on mild steel sheet; (left) fine grain, (right) coarse grain. (Courtesy Tinus Olsen Testing Machine Co., and Research Laboratories, The American Rolling Mill Company.)



## STAINLESS STEEL

Certain of the so-called stainless steels, notably those of the 18:8 variety, containing 18% Cr – 8% Ni – rem. Fe, have been used extensively both for deep drawing and for architectural trim.<sup>6</sup> Although their initial cost is high, they form well, have a pleasing appearance, and last almost indefinitely under most atmospheric conditions. However, these alloys are intended essentially to give combinations of strength with a resistance to forms of corrosion much more severe than atmospheric, and hence will be discussed in more detail in Chaps. XV and XVI.

## COPPER

Copper has been used widely for a long time, in the form of sheet, for roofing and other purposes involving atmospheric corrosion. These uses are dictated by its ease of fabrication in sheets of almost any desired thickness, its flexibility, its ease of assembly by soldering, and by the protective coating, or *patina*, formed on it with time.<sup>7</sup> The green color of the patina is particularly attractive. However, it requires approximately 10 yr to form depending upon the atmospheric conditions, and methods have been developed for producing an *artificial patina* on small objects much more rapidly.<sup>8</sup> Whether this will equal the natural patina in its protection against corrosion, however, still is not established definitely.

Copper generally is used only in supported roofs. This is desirable not only because of its weight and cost, but also because it permits the use of thinner sheets. Lead-coated copper sheets for roofing purposes are covered by A.S.T.M. Standard B101.

Rolled copper sheet for roofing generally is used in a thickness of about 0.022 in. (1 lb per sq ft). However, a process has been developed in which a much thinner *electro-sheet* 0.0013–0.009 in. thick in 60-in. widths (1–7 oz per sq ft) is deposited electrolytically in sheets of unlimited length by one pass through the electrolyte.<sup>9</sup> The use of an undercoating, such as canvas, felt, wood, or impregnated fabric, cushions such a thin coating and thereby lessens the danger of puncturing it.

Electrolytic tough-pitch copper containing about 0.03–0.07% oxygen (as

<sup>6</sup> See W. Van Alen in Chap. 20 and L. W. Hostettler in Chap. 6G in Ref. 9 at the end of this chapter.

<sup>7</sup> See W. H. J. Vernon, *Journ. Chem. Soc.*, 1934, 1853–1859.

<sup>8</sup> See, for example, the electrolytic method of W. H. J. Vernon, *Journ. Inst. Met.*, London, 49, 1932, 153.

<sup>9</sup> See A. L. O'Brien, *Met. Ind.*, London, 52, 1938, 549–550.

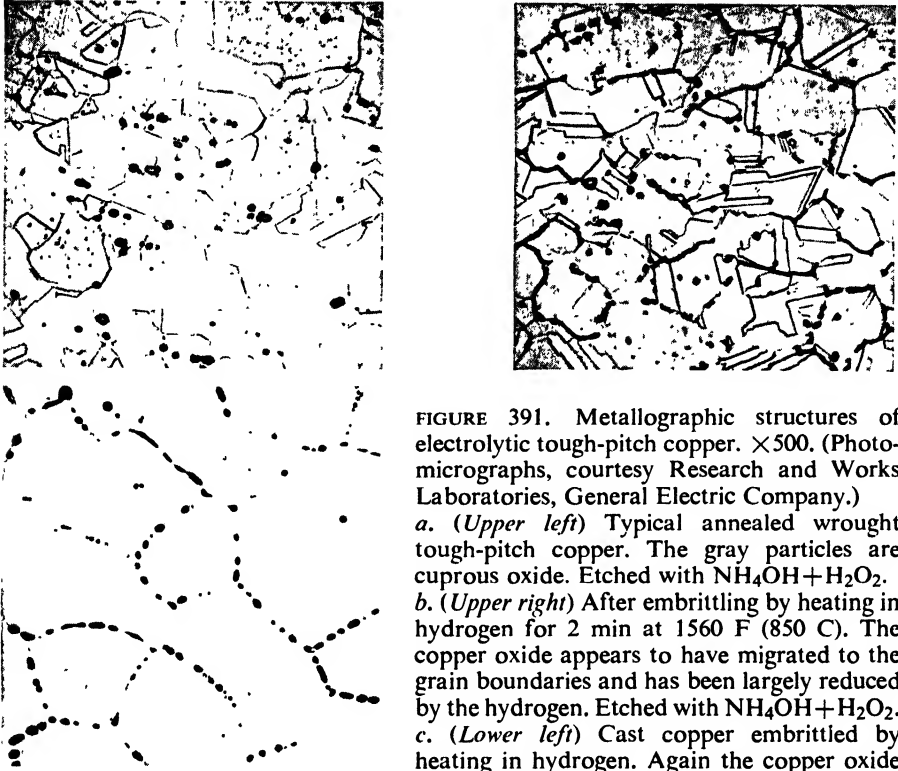


FIGURE 391. Metallographic structures of electrolytic tough-pitch copper.  $\times 500$ . (Photomicrographs, courtesy Research and Works Laboratories, General Electric Company.)

*a.* (Upper left) Typical annealed wrought tough-pitch copper. The gray particles are cuprous oxide. Etched with  $\text{NH}_4\text{OH} + \text{H}_2\text{O}_2$ .

*b.* (Upper right) After embrittling by heating in hydrogen for 2 min at 1560 F (850 C). The copper oxide appears to have migrated to the grain boundaries and has been largely reduced by the hydrogen. Etched with  $\text{NH}_4\text{OH} + \text{H}_2\text{O}_2$ .

*c.* (Lower left) Cast copper embrittled by heating in hydrogen. Again the copper oxide

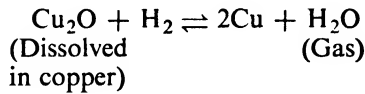
appears to have migrated to the grain boundaries and has been largely reduced. Unetched. Original magnification shown; reduced about one third in reproduction.

$\text{Cu}_2\text{O}$ ) with the balance essentially copper, is used most generally for roofing sheets. The oxygen will appear in a metallographic section of the cast structure, such as those shown in Fig. 529, as an eutectic of copper and cuprous oxide,  $\text{Cu}_2\text{O}$ , which can be seen readily at the grain boundaries. After working and annealing (Fig. 391*a*), the oxide is distributed throughout the structure as small particles in a background of twinned polyhedral grains of copper. Its effect on mechanical properties is not great although it increases the ductility somewhat and reduces the tensile strength (cf. Figs. 61 and 531).

#### HYDROGEN EMBRITTLEMENT OF COPPER

All copper alloys which contain appreciable amounts of either  $\text{Cu}_2\text{O}$  or of the copper-cuprous oxide eutectic are liable to serious embrittlement when heated under reducing conditions, especially those in which hydrogen

is the reducing agent.<sup>10</sup> Under these conditions the hydrogen is believed to react with the copper oxide to form steam and sponge copper. The pressure caused by the release of the steam literally blows the copper apart, causing a separation at the grain boundaries and consequent lack of cohesion between the grains. The effect of this on the microstructure is illustrated in Fig. 391*b* for wrought material and in 391*c* for a casting. Although both the hydrogen and the steam formed would occupy equal volumes if both were present as a gas, the hydrogen is believed to be dissolved in the copper until the steam is formed. The steam, being insoluble, is liberated as a gas under high pressure and thereby causes most of the difficulty.



#### THE ALPHA BRASSES

The wrought alloys of copper and zinc, called the *brasses*, are used widely for purposes involving deep drawing although their tendency to stain when exposed to the weather makes protective coatings desirable in most cases. The alloys vary in color from red through gold to yellow (Fig. 211), depending upon the percentage of zinc, but almost invariably form a green corrosion product because of their copper content.

The brasses usually are classified, according to their zinc contents, into the six groups listed below:

1. *Gilding metal* (95% Cu – 5% Zn)
2. *Commercial bronze* (90% Cu – 10% Zn)
3. *Rich low, or red brass* (85% Cu – 15% Zn)
4. *Low brass* (80% Cu – 20% Zn)
5. *High, or cartridge brass* (70% Cu – 30% Zn)
6. *Common high, high yellow, or drawing brass* (66% Cu – 34% Zn)

Alloys containing more than 64% copper are composed of the  $\alpha$  primary solid solution as indicated in the constitutional diagram in Figs. 207 and 209. As such they are composed of typical twinned crystals, face-centered cubic in structure like the base metal copper. In Fig. 392 are shown the differences in appearance of cartridge brass resulting from a light or heavy etch with the customary ammonium hydroxide-hydrogen peroxide solution. Except for a difference in color resulting from their composition, or of grain size resulting from their heat treatment, all the *alpha* brasses have essentially the same metallographic appearance.

<sup>10</sup> See L. L. Wyman, *Trans. A.I.M.E.*, 1931 Preprint; 104, 1933, 141–151; 111, 1934, 205–213; 137, 1940, 291–296.



FIGURE 392. Metallographic structures of annealed cartridge brass (70% Cu — 30% Zn), grain size 0.050–0.055 mm. Etched with  $\text{NH}_4\text{OH} + \text{H}_2\text{O}_2$ .  $\times 75$ . (Left) Light etch. (Right) Contrast etch.

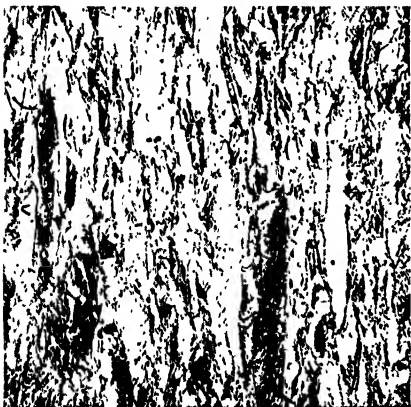
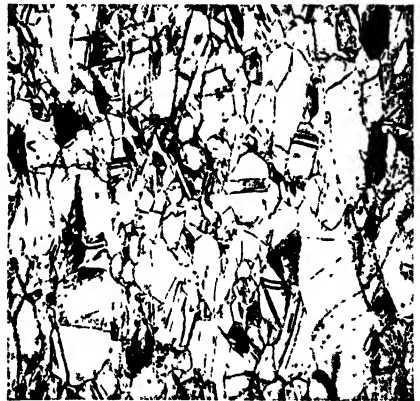
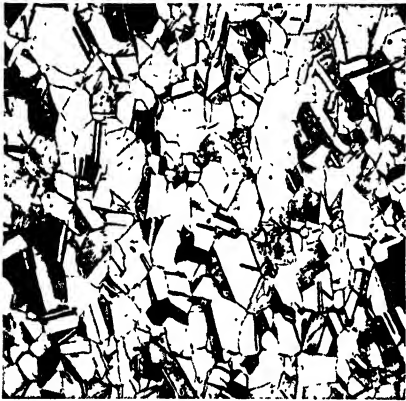


FIGURE 393. Metallographic structures of cartridge brass (70% Cu — 30% Zn) cold-rolled to various tempers. Etched with  $\text{NH}_4\text{OH} + \text{H}_2\text{O}_2$ .  $\times 75$ . (Upper left) Half hard (21% reduction in thickness). (Upper right) Hard (37% reduction in thickness). (Lower left) Spring (60% reduction in thickness).

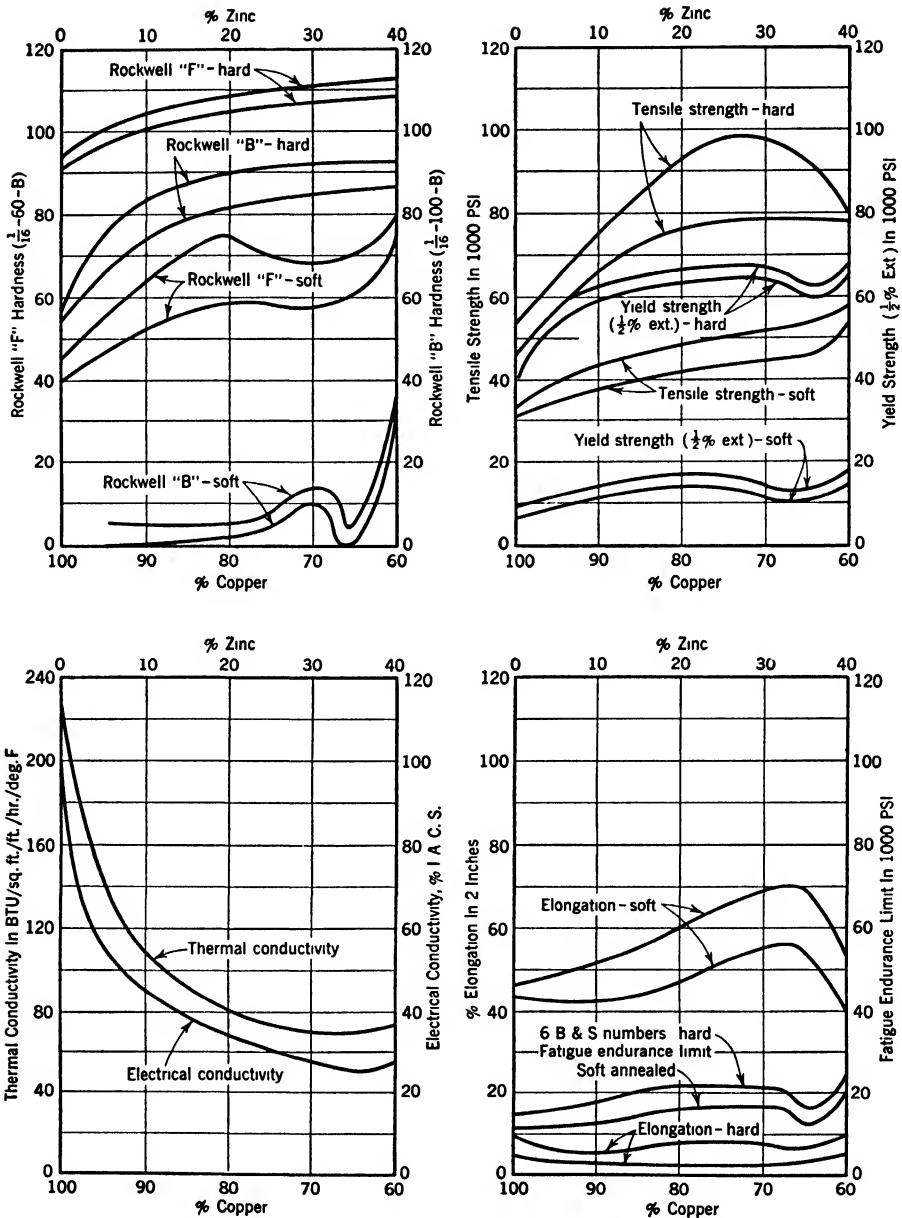


FIGURE 394. Effect of composition on several mechanical and physical properties of copper-zinc alloys in various tempers.

The effect of cold-work on structure, as exemplified by cartridge brass, is shown in Fig. 393 for the commercial half-hard, hard, and spring tempers. Figure 394 illustrates the effect of composition on some of the mechanical

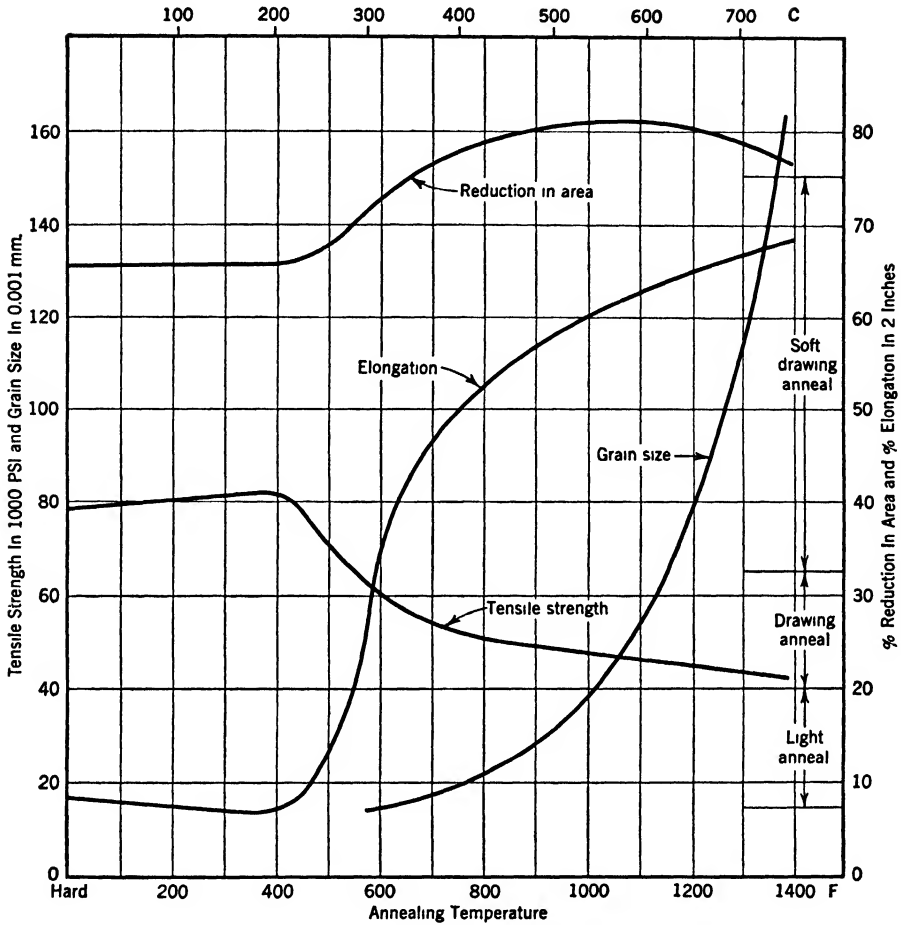


FIGURE 395. Effect of annealing temperatures on the properties of high brass. (After W. R. Webster, *Trans. A.I.M.E.*, 147, 1942, 13-27.)

and physical properties of the brasses for various tempers. The alloys in all tempers are covered by A.S.T.M. Tentative Standard for Brass Sheet, B36-T, and Cartridge Brass is covered by B19-T. Some compositions are also covered by S.A.E. Nos. 70 and 79.

For deep drawing, the alloys containing less than 80% copper are used most commonly, the grain size being kept small. Cold-worked metal will recrystallize at temperatures ranging from 475-650 F (250-350 C), depending upon the amount of working. The change in properties so produced by annealing is shown in Fig. 395 for a high brass (66% Cu - 34% Zn). The rapid increase in grain size with annealing temperature is particularly striking.

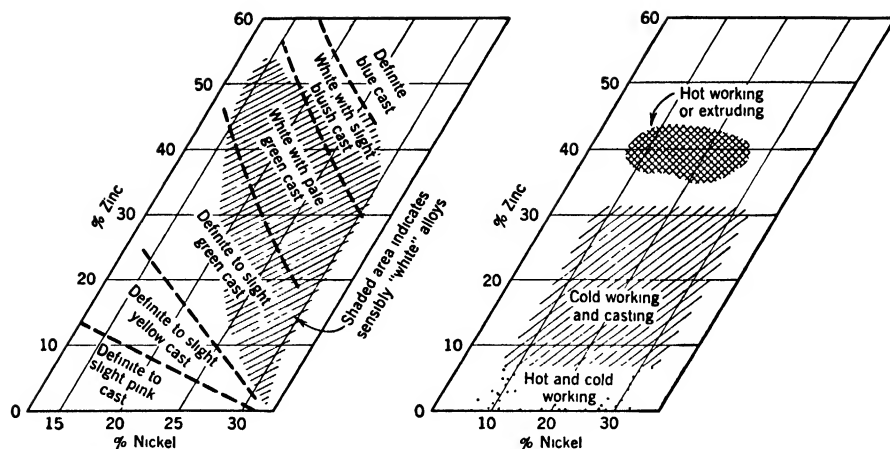


FIGURE 396a. (Left) Color trends of copper-nickel-zinc alloys. b. (Right) Composition ranges of nickel silvers with reference to working characteristics. (After T. E. Kihlgren, N. B. Pilling and E. M. Wise, *Trans. A.I.M.E.*, 117, 1935, 279–309.)

Grain size and hardness are the properties most readily and commonly determined and either will correlate well with the tensile strength.

The brasses have been used for almost every application requiring high formability and some corrosion resistance. The particular alloy selected for a given application is determined by the allowable cost, color, and the other general characteristics desired. An additional advantage is the ease with which they can be assembled by soft soldering or silver brazing.

#### NICKEL SILVER

The alloys of copper, nickel, and zinc, called nickel silvers or german silvers, are among the few silvery-white alloys with a copper base although, as indicated in Fig. 396a, they are not true white in color. The commercial alloys generally contain 60–65% copper, 7–30% nickel, and the remainder zinc.<sup>11</sup> The ranges of compositions commonly used are indicated on the copper corner of the copper-nickel-zinc ternary diagram in Fig. 396b although the commercial alloys conform to much more rigid composition limits than are shown. Within the ranges given, the hot-working alloys high in copper and all the cold-working alloys are copper-rich  $\alpha$  solid solutions with a typical structure similar to that of the alpha brasses although it is somewhat more difficult to delineate metallographically because of the slower etching rate of the alloys containing nickel. The structure of the ex-

<sup>11</sup> These alloys are discussed thoroughly by T. E. Kihlgren, N. B. Pilling and E. M. Wise, *Trans. A.I.M.E.*, 117, 1935, 279–309.

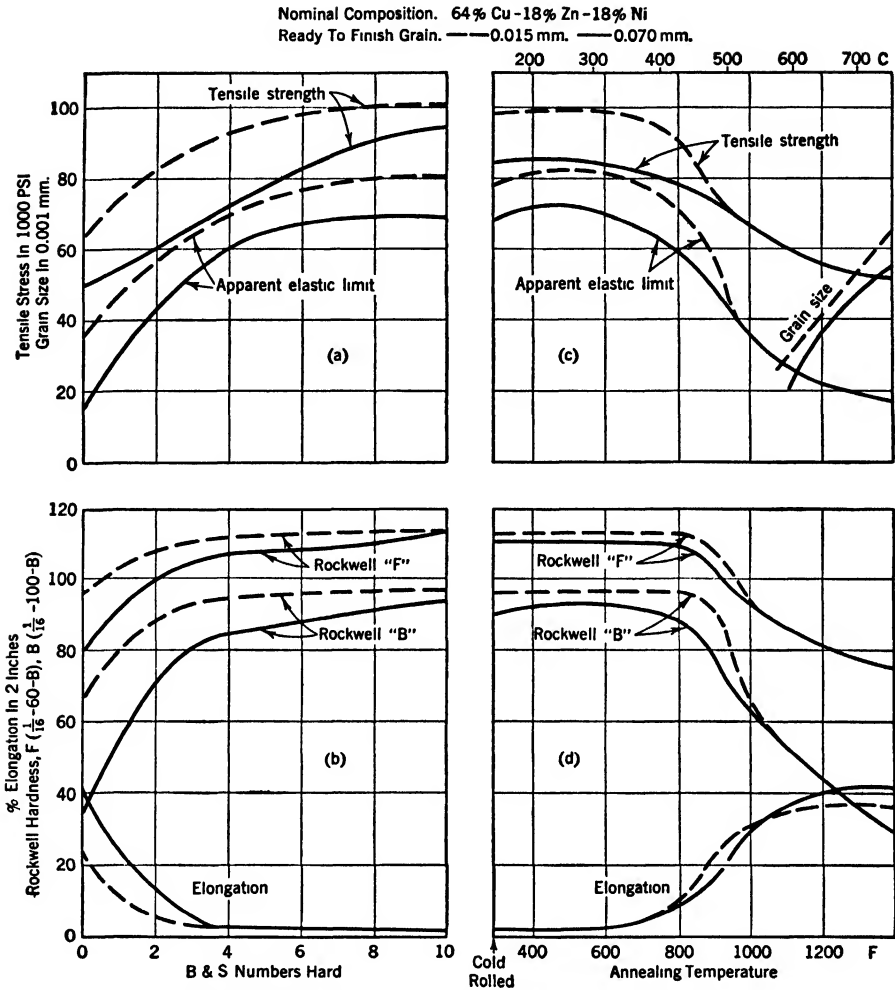


FIGURE 397. *a.* and *b.* Mechanical properties of 18% nickel silver sheet cold-rolled from metal of two different ready-to-finish grain sizes. *c.* and *d.* Mechanical properties of 18% nickel silver sheet cold-rolled from metal of two different ready-to-finish grain sizes then finish annealed. (From *Metals Handbook*, courtesy American Society for Metals.)

truded alloys generally will consist of both the  $\alpha$  and  $\beta$  solid solutions and, consequently, they only can be hot-worked readily.

It is customary to refer to the nickel silver alloys according to their nickel content. Thus "18% nickel silver" is an alloy containing 18% nickel regardless of the ratio of copper and zinc. The exact percentages of these elements may vary, in fact, depending upon the specific application.

The change in properties produced by cold-working and by annealing 18% nickel silver is shown in Fig. 397. In the annealed form tensile strengths



average 50,000–60,000 psi, with proof stresses of 15,000–20,000 psi and elongations of 30–50%. All of the tensile properties can be increased markedly and rapidly by cold-reduction because of the high rate of work-hardening.

Machinability can be improved by adding about 1% lead, but this is harmful to the deep-drawing characteristics, and also increases the tendency to *fire crack*, i.e., crack during annealing or on sudden application of heat because of a too rapid release of internal strain.

The alloys are used as a base for flatware and hollowware electroplated with silver, for some food-handling equipment, and marine fittings in addition to their architectural uses. They also are used extensively in the optical and jewelry industries both in their normal form and as a base in rolled gold and gold-filled constructions. In the strip form they are used widely for spring elements in electrical relays. The leaded alloys commonly are used for all kinds of builders' hardware, such as screws, keys, valves, nuts, bolts, and lock parts.

#### ALUMINUM-BASE ALLOYS

The wrought aluminum-base alloys which fall in this group may be classified under two headings, depending upon whether they can be hardened by heat-treatment or only by cold-work. In either case the letter "S" indicates a wrought alloy in the terminology of the Aluminum Company of America which is used most commonly. The heat-treatable alloys offer the highest strengths, but require precise treatment in order to secure maximum properties. When the alloys are to be deep drawn, the same general principles already mentioned hold, a small grain size being preferred for the best surface.

#### WORK-HARDENABLE ALUMINUM ALLOYS

There are three work-hardenable alloys commonly used for applications involving deep drawing. These are designated, by the Aluminum Company of America, as 2S, 3S, and 52S. Typical compositions are:

ALCOA NO.	% MN	% CU	% MG	% CR
2S		(Iron plus silicon about 0.8%)		
3S	1.0–1.5	0.2 (max)	—	—
52S	—	—	2.5	0.25

with the remainder, in each alloy, being aluminum. A.S.T.M. Tentative Standard B211-T includes alloy 2S, and S.A.E. No. 25, 29, and 201 are 2S, 3S, and 52S, respectively.

The metallographic structures of these three alloys are shown in Fig. 398. Despite their apparent differences they are all basically the same. The particles shown are formed largely by interaction between the aluminum and the impurities, principally silicon and iron. The alloying elements are soluble in aluminum.

Typical mechanical properties for 2S and 52S are given in Table XIX.

TABLE XIX TYPICAL MECHANICAL PROPERTIES OF 2S AND 52S

TEMPER†	TENSILE STRENGTH, PSI		YIELD STRENGTH (0.2% SET), PSI		ELONGATION,* % IN 2 IN.		BRINELL HARDNESS (10 MM-500 KG)	
	2S	52S	2S	52S	2S	52S	2S	52S
-O	13,000	29,000	5,000	14,000	35	25	23	45
-H12	15,000	34,000	13,000	26,000	12	12	28	62
-H14	17,000	37,000	14,000	29,000	9	10	32	61
-H16	20,000	39,000	17,000	34,000	6	8	38	74
-H18	24,000	41,000	21,000	36,000	5	7	44	85

\* These elongation values are for  $\frac{1}{16}$ -in. sheet. Thicker material has higher elongation, thinner, has lower.

† The -H2 temper designation is also used with alloys 2S and 3S; the -H1, -H2 and -H3 temper designations are all used with 52S; but for the -H2 or -H3 tempers somewhat different properties would be expected.

The annealed (recrystallized) temper is designated by the letter “-O” and the strain-hardened temper by one of the following symbols:

-H1, plus one or more digits. Strain hardened only.

-H2, plus one or more digits. Strain hardened and then partial annealed.

-H3, plus one or more digits. Strain hardened and then stabilized.

The letter “-F” signifies “as fabricated.”

The tensile properties of alloy 3S are about 20% better than those of commercially pure aluminum (2S), whereas those of 52S are about double those of 2S. Alloy 52S also has the highest endurance limit, 17,000–19,000 psi, of any of the nonheat-treated wrought aluminum alloys. The resistance of all three alloys to both atmospheric and salt-water corrosive conditions is

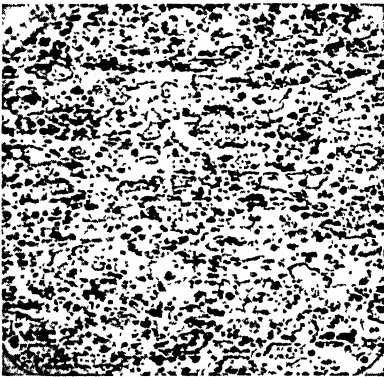
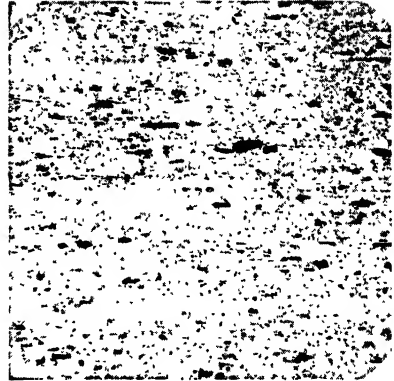
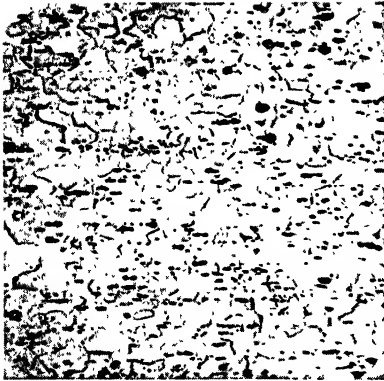


FIGURE 398. Metallographic structures of annealed commercially pure aluminum, 2S-O (*upper left*) and aluminum alloys 3S-O (1.2% Mn - rem. Al) (*upper right*) and 52S-O (2.5% Mg - 0.25% Cr - rem. Al) (*lower left*) in the sheet form. Etched with  $\frac{1}{2}\%$  HF.  $\times 100$ . (Photomicrographs courtesy Aluminum Research Laboratories.)

quite good and about the same, because of their property of forming a thin, adherent protective coating of oxide on the surface.

In their general applications, 2S would be used for the most severe drawing, stamping, and spinning operations, such as in cooking utensils and some chemical equipment; and the stronger alloys would be used for applications where the formability requirements were not so severe and more strength was required such as for roofing, flashing, gutters, and doors, and in railway construction for furniture, paneling, and siding stock. In none of the alloys are the strengths more than moderate so the properties of none of them would compare with those of either the heat-treated alloys described below or the stronger, heat-treated, constructional alloys of aluminum which are dealt with in Chap. XVI.

The temperature for full annealing varies with the purity, being about 650 F (340 C) for 2S and 775 F (410 C) for 3S and 52S, followed by air cooling in each case. Any of the alloys can be welded readily if the standard techniques recommended for aluminum alloys are used.

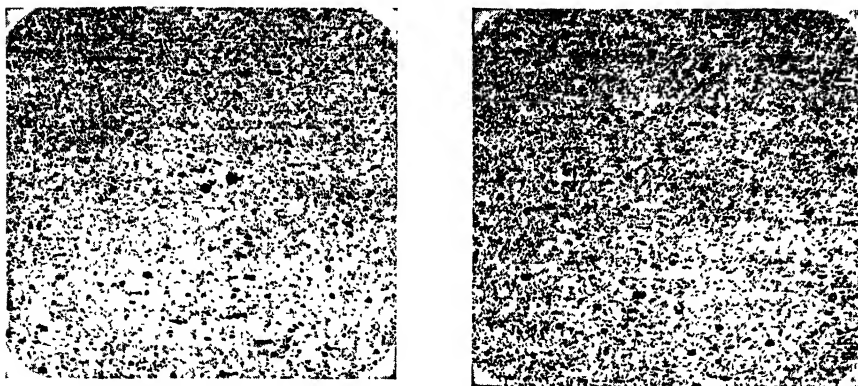


FIGURE 399. Metallographic structures of annealed aluminum alloys 53S-O (0.7% Si - 1.3% Mg - 0.25% Cr - rem. Al) (*left*) and 61S-O (0.6% Si - 1.0% Mg - 0.25% Cu - 0.25% Cr - rem. Al) (*right*) in the sheet form. Etched with  $\frac{1}{2}\%$  HF.  $\times 100$ . (Photomicrographs courtesy Aluminum Research Laboratories.)

#### HEAT-TREATABLE ALUMINUM ALLOYS

Two heat-treatable alloys, 53S and 61S, also are used for applications for which formability is important. Their nominal compositions, in addition to aluminum, are:

ALCOA NO.	% SI	% MG	% CU	% CR	% OTHER IMP.
53S	0.7	1.2	—	0.25	0.55 max
61S	0.6	1.0	0.25	0.25	

A.S.T.M. Tentative Standards B209-T, B210-T, and B211-T all include 61S as alloy GS21; S.A.E. No. 281 is similar.

The metallographic structures of these alloys in the annealed condition are similar to those shown in Fig. 399. Except for impurities, they consist of a small amount of the compound  $Mg_2Si$ , difficultly seen at low magnifications, in a matrix of the aluminum-rich solid solution in which the other elements are dissolved. Mechanical properties are determined largely by the temper, which is designated by “-F” if as fabricated; “-O” if annealed (recrystallized); “-H1,” “-H2,” or “-H3” plus one or more digits, if strain hardened; “-W” if given the solution treatment only (i.e., as quenched, and therefore unstable); and “-T” if treated to produce a stable temper other than “-F,” “-O,” or “-H.” Subdivisions of “-T” temper that are used are:

- T2 Annealed (cast products only).
- T3 Solution heat treated and then cold worked.
- T4 Solution heat treated.
- T5 Artificially aged only.
- T6 Solution heat treated and then artificially aged.
- T7 Solution heat treated and then stabilized.
- T8 Solution heat treated, cold worked, and then artificially aged.
- T9 Solution heat treated, artificially aged, and then cold worked.
- T10 Artificially aged and then cold worked.

The resistance of all tempers of 53S to industrial atmospheres and to salt spray is almost as good as that of 2S and is greater than that of any of the other heat-treatable aluminum alloys. Alloy 61S is somewhat inferior to 53S in salt water or salt spray but is comparable with it when exposed to industrial atmospheres.

The mechanical properties of both of these alloys will fall, roughly, within the ranges shown in Table XX.

TABLE XX RANGE OF TYPICAL MECHANICAL PROPERTIES FOR THE ALLOYS 53S AND 61S

TEMPER	TENSILE STRENGTH, PSI	YIELD STRENGTH, PSI	ELONGATION, % IN 2 IN.	BRINELL HARDNESS (10 MM-500 KG)
-O	16,000-18,000	7,000- 8,000	35-22	26-30
-T4	33,000-35,000	20,000-21,000	30-22	64-65
-T6	40,000-45,000	33,000-40,000	14-12	80-95

The properties of both alloys can be increased considerably by cold-work. They are worked easily and are formed readily in either the annealed or the solution-treated conditions although 61S is somewhat better than 53S in this respect because it work-hardens much less rapidly. They both can be welded by standard methods.

For heat-treatment, a solution treatment should be given in the range 960-980 F (515-525 C) followed by cold-water quenching and subsequent aging for 18 hr at 315-325 F (155-160 C) or 8 hr at 345-355 F (175-180 C). As with the nonaging alloys, annealing can be carried out by air cooling from 650-750 F (340-400 C) after holding at temperature for times which may have to be as long as 2 hr. Moderate strength, good formability, and high resistance to corrosion characterize these alloys. They find their prin-

principal application in architecture and marine construction where the combination of these properties with lightness of weight can be utilized best.

#### WROUGHT MAGNESIUM ALLOYS

The alloys of magnesium base used in sheet form to resist atmospheric corrosion are of importance chiefly because of their light weight.<sup>12</sup> Magnesium is only two thirds the weight of aluminum and about one quarter the weight of brass or iron. Consequently, appreciable weight reductions result in many cases from using it. Four alloys commonly used for sheet metal are designated in different manners by the two principal producers, the Dow Chemical Company (*Dowmetal*<sup>13</sup>) and the American Magnesium Corporation (*Mazlo*<sup>13</sup>). In the Dow terminology the letter "a" following the alloy symbol, e.g., Ea, signifies annealed temper, and the letter "h," e.g., Eh, indicates hard rolled.

The nominal compositions are:

DESIGNATION		A.S.T.M.	S.A.E.	% AL	% MN (MIN)	% ZN (MAX)
DOW CHEMICAL COMPANY	AMERICAN MAGNESIUM CORPORATION	B90-T				
<i>J-1</i>	AM57S	—	511	5.8–7.2	0.15	0.4–1.5
<i>FS-1</i>	AM52S	AZ31X	510	2.5–3.5	0.20	0.6–1.4
<i>M</i>	AM3S	M1	51	—	1.20	—
<i>JS-1</i>	—	AZ51X	512	4.1–5.5	0.15	0.4–1.3

the remainder in each alloy being magnesium. Limitations usually are placed on the maximum amounts of silicon (0.3%), copper (0.05%), and nickel (0.03%). These alloys are covered by A.S.T.M. and S.A.E. Standards as indicated although in a few cases the alloys shown do not correspond exactly to the specifications.

Dowmetal J-1, JS-1 and FS-1 have mechanical properties superior to those of Dowmetal M, good forming characteristics, and are used for general applications requiring these properties. The Dowmetal M alloy, however, has much better corrosion resistance, especially to salt water, and is usually considered to form more readily than the other alloys. Alloy J-1 is particularly suited for aircraft use with good strength and about the same

<sup>12</sup> General tensile properties of these alloys are discussed by J. C. McDonald, *Trans. A.I.M.E.*, 137, 1940, 430–441; 143, 1941, 179–181.

<sup>13</sup> Registered trade-marks.

forming characteristics as the other alloys. The A.S.T.M. alloy AZ51X is the strongest of the alloys and is used where strength and weldability are the primary factors.

In all the alloys the copper, nickel, and iron contents should be kept low to minimize corrosion. A special grade, AZ90X, is listed in the A.S.T.M. Standard for this express purpose, the copper being held to 0.05% (max), the nickel to 0.002% (max), and iron to 0.004% (max). These alloys, in the terminology of American Magnesium Corporation, use an "AMC" number instead of "AM."

Typical properties are within the following ranges, the specific limits depending on the alloy:

TEMPER	TENSILE STRENGTH, PSI	YIELD STRENGTH (0.2 DEV. FROM MOD. LINE), PSI	ELONGATION, % IN 2 IN.	BRINELL HARDNESS (10 MM-500 KG)
Hard rolled (h)	32,000-50,000	22,000-34,000	8-3	53-70
Annealed (a)	32,000-46,000	16,000-24,000	16-12	40-55

Specific gravities will range from 1.76 to 1.80, again depending on the alloy. The modulus of elasticity will average about 6,500,000 psi.

In none of the alloys are the strengths very high although, when considered on a strength-weight basis, they are adequate. However, the alloys usually are not recommended for applications subjected to high stresses, and the cold-rolled tempers should not be used where subject to shock loads. The cold-working properties of these materials are not too good, however, and some form of hot-working in the range 550-600 F (285-315 C) is used almost entirely.

Although the alloys are resistant to atmospheric corrosion, they tend to darken and become dull in appearance. Hence they usually are protected by painting, especially when exposed to salt atmospheres, as they are particularly susceptible to this form of attack.

Despite the shape of the solubility curve in the magnesium-aluminum equilibrium diagram, alloys containing less than about 9% aluminum are not susceptible to age-hardening. The structure of the alloys is typified by those of Dowmetal J-1 and FS-I, photomicrographs of which are shown in Fig. 400, and Dowmetal M, shown in Fig. 479. The manganese is largely in solid solution, although a small amount may appear as particles of a second phase, which is believed by some to be metallic manganese, in some of these alloys. The aluminum is partly dissolved in the magnesium-rich solid solu-

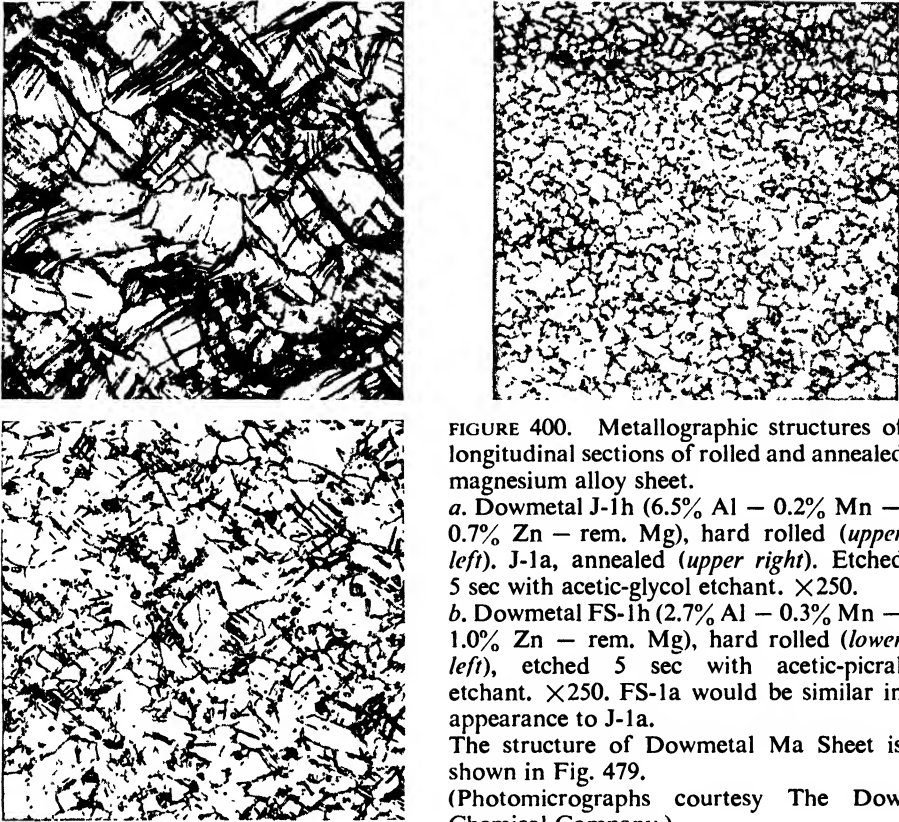


FIGURE 400. Metallographic structures of longitudinal sections of rolled and annealed magnesium alloy sheet.

*a.* Dowmetal J-1h (6.5% Al – 0.2% Mn – 0.7% Zn – rem. Mg), hard rolled (*upper left*), J-1a, annealed (*upper right*). Etched 5 sec with acetic-glycol etchant.  $\times 250$ .

*b.* Dowmetal FS-1h (2.7% Al – 0.3% Mn – 1.0% Zn – rem. Mg), hard rolled (*lower left*), etched 5 sec with acetic-picral etchant.  $\times 250$ . FS-1a would be similar in appearance to J-1a.

The structure of Dowmetal Ma Sheet is shown in Fig. 479.

(Photomicrographs courtesy The Dow Chemical Company.)

tion matrix and partly precipitated as a second phase, the  $\gamma$  secondary solid solution ( $\text{Al}_2\text{Mg}_3$ ), which usually is found at the grain boundaries. Cold-working produces prominent mechanical twinning as readily can be seen from the rolled structures.

#### LEAD AND ITS ALLOYS

Although lead has certain advantages in architectural applications, because of its resistance to atmospheric corrosion and its pleasing appearance even when corroded, it is being used relatively little today. The chief disadvantage is its weight. This factor naturally relegates it to a comparatively minor position since the use of it for trim would increase greatly the dead load to be carried. It still is used as a coating for steel and copper but even in these cases it usually is alloyed with some tin to increase its adherence and to enable it to be applied to the base metal more easily. Its low strength prevents its use for drastic forming operations.

Certain lead alloys, notably those containing small amounts of calcium,



magnesium, and tin, such as the commercial *Roofloy*,<sup>14</sup> and the tellurium-lead alloys have mechanical properties and creep resistance superior to ordinary lead and hence can be used in thinner sheets with a consequent saving in weight. Metallographic structures of these alloys are shown in Figs. 69 and 456.

#### NICKEL AND MONEL METAL

A process for the electrodeposition of thin sheets of nickel,<sup>15</sup> similar to that used for copper, may make it a competitor in the roofing field. However, when rolled sheets are used both nickel and its principal alloy with copper, *Monel metal* (approximately 70% Ni – 30% Cu), are generally too expensive to offer much competition to the cheaper materials available. They have been used very satisfactorily in certain installations such as the roof of the Pennsylvania Station in New York City. The cost of both of these materials is sufficiently high that they compete mostly for applications in which corrosive conditions are more severe than those encountered by the alloys dealt with in this chapter. They will be discussed in more detail in Chap. XV.

#### ROLLED ZINC ALLOYS

A patented alloy of the New Jersey Zinc Company called *Zilloy*,<sup>16</sup> containing 0.75–1.25% copper, 0.007–0.02% magnesium, 0.05–0.12% lead, a maximum of 0.015% iron and 0.005% cadmium, and the remainder zinc, possesses very good stiffness, and is used for corrugated roofing and siding in competition with galvanized iron. Its cost is appreciably greater, but because of its greater life it can compete successfully in some localities. The alloy can be annealed by heating to 480 F (250 C). It will then have a strength of 18,000–30,000 psi with an elongation of 50–20% depending upon the analysis. By cold-rolling, it can be hardened to give strengths of 26,000–50,000 psi with elongations of 60–20%.

The metallographic structures, in both the hot-rolled and hard-rolled conditions, of the 1% copper alloy under polarized light are illustrated in Fig. 401a. The copper is largely found in solid solution in the zinc-rich matrix, but the magnesium, despite the extremely small amount present, occurs as very fine hard particles, probably of the intermetallic compound  $MgZn_5$ , scattered through and between the crystals. It is thought to be the presence of these particles which imparts the resistance to sagging to this

<sup>14</sup> Registered trade-mark.

<sup>15</sup> Details can be secured from The International Nickel Co., Inc., 67 Wall St., New York, N. Y.

<sup>16</sup> Registered trade-mark.

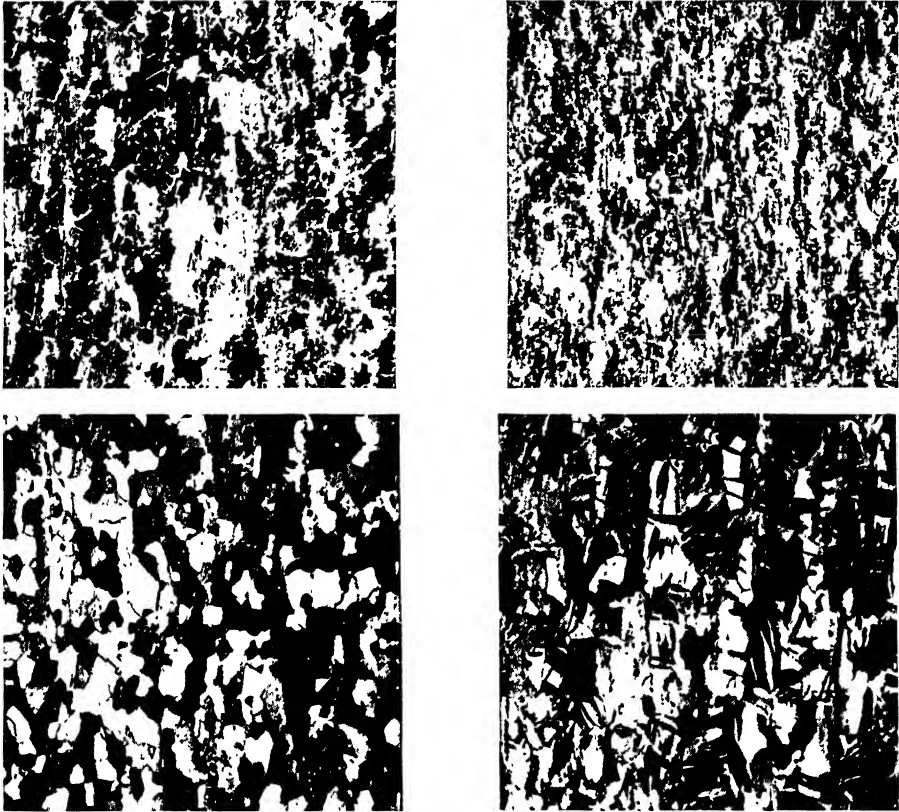


FIGURE 401. Metallographic structures typical of rolled zinc alloys.

a. 1% copper alloy. Hot-rolled (*upper left*), hard-rolled (*upper right*). Etched with solution containing 20 g  $\text{CrO}_3$ , 0.75 g  $\text{Na}_2\text{SO}_4$ , 100 ml  $\text{H}_2\text{O}$ . Polarized light.  $\times 200$ .

b. Commercial rolled zinc. Hot-rolled (*lower left*), hard-rolled (*lower right*). Etched with solution containing 20 g  $\text{CrO}_3$ , 1.5 g  $\text{Na}_2\text{SO}_4$ , 100 ml  $\text{H}_2\text{O}$ . Polarized light.  $\times 200$ . (Photomicrographs courtesy Research Division, Technical Department, The New Jersey Zinc Company.)

alloy. In this respect this material is superior both to pure zinc and to the other rolled zinc alloys.

The alloy falls within the limits of the A.S.T.M. Standard for Rolled Zinc, B69, an Appendix to which also discusses thoroughly many of the tests used in this trade. This specification covers rolled zinc of three different types, which might be used for a relatively wide variety of applications. Large amounts, for example, are deep drawn into shells for dry batteries. Although no chemical limits are indicated in the specification, several commercial alloys are available containing various percentages of lead, iron, cadmium, copper, and magnesium, all in fairly small amounts. The specific alloy selected depends upon the application for which it is intended.

The metallographic structures typical of a hot-rolled and of a hard-rolled commercial zinc under polarized light are shown in Fig. 401*b*. Mechanical twinning is readily apparent in the hard-rolled structure but the hot-rolled material is free from it.

### *Hardware and Fittings*

Alloys used for hardware and similar applications generally have to bear some load, but in no case is this load comparable to that borne by the constructional alloys. Consequently, strength is again a relatively minor factor in their selection. For these materials, probably the most important factors are appearance and ease of fabrication. Although the net cost is determined largely by the latter, the former must be considered since popular fancy is frequently much more significant in determining ultimate sales appeal than the actual cost to the consumer. Ease of fabrication is important because decreased costs arise from the use of such fabricating methods as casting, die casting, and extrusion for obtaining the outward shape of the material, and from free-machining characteristics for finishing it.

The alloys included in this classification may or may not be used without protective coatings, and in many instances the protective coating is added as much for appearance as it is for any corrosion-resisting purpose.

### FREE-MACHINING ALLOYS

Alloys which can be machined at high speeds in automatic screw machines usually are said to be free machining or free cutting. Such materials must cut readily and give a fine chip which can be removed readily. Probably the most important of them are the leaded brasses, copper containing selenium, tellurium, or lead, and the high-sulfur and leaded steel screw stocks. An aluminum alloy containing small amounts of both lead and bismuth has been developed specifically for this purpose, and when properly used, has proved to be very satisfactory. Magnesium-base alloys in general have excellent machinabilities, although some precautions must be taken because of the possible fire hazard caused by the high chemical activity of this metal, especially in a finely divided form.

### STEEL SCREW MACHINE STOCK

Steels intended for automatic screw machine use are almost all of the S.A.E. 11xx or X13xx grades. These may run as high as 0.25% sulfur,

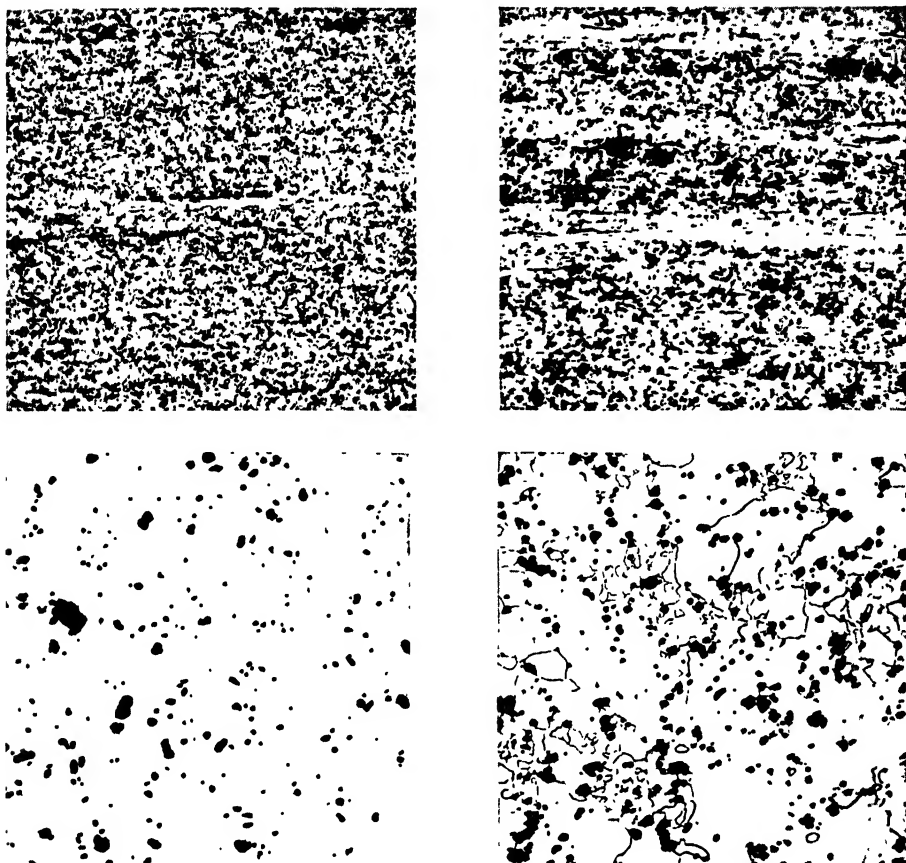


FIGURE 402. Metallographic structures of free-machining types of carbon steels.  
*a.* High sulfur, showing stringer-like inclusions of FeS and MnS in both a process annealed (*upper left*) and a normalized (*upper right*) section. Etched with nital.  $\times 100$ .  
*b.* Graphitic, showing nodules of free graphite in both an unetched (*lower left*) and a nital etched (*lower right*) ferritic matrix.  $\times 100$ .

0.13% phosphorus, or 1.5% manganese, depending upon the particular steel and the application for which it is intended. The higher manganese contents are not used, as a rule, in the high sulfur and phosphorus steels. The carbon content is usually less than 0.40% and most frequently is 0.10–0.20%. The leaded steels,<sup>17</sup> such as the commercial alloy *Ledloy*,<sup>18</sup> contain about 0.25% lead.

Both the manganese and phosphorus embrittle the ferrite to some extent, and, therefore, permit the chip to break off more easily. The sulfur, as FeS or MnS inclusions similar to those shown in Fig. 402*a*, acts as a chip

<sup>17</sup> See F. J. Robbins and G. R. Caskey, *Trans. A.S.M.*, 27, 1939, 887–915.

<sup>18</sup> Registered trade-mark.

breaker also; and the function of the lead is probably similar, although it is so finely divided that its metallographic detection has been extremely difficult. For optimum machinability some control of austenitic grain size is also desirable.<sup>19</sup>

Certain higher carbon steels also may be made much more machinable by special heat-treatments that facilitate the formation of graphite instead of cementite in their structure,<sup>20</sup> as illustrated in Fig. 402*b*.

The mechanical properties of the free-machining steels do not differ greatly from those of similar plain carbon steels. However, as might be expected, their brittleness is apt to be greater, especially if the sulfur and phosphorus are high. They commonly are made by the Bessemer process in an appreciable tonnage. However, some types are made in the open-hearth furnace, and were originally developed specifically to enable steels made by this process to compete with the Bessemer steels in these applications.

#### MACHINABLE CAST IRONS

Both gray and malleable cast iron will machine very well, because of the large amount of free graphite in their structures, provided proper precautions are taken.<sup>21</sup> The size and distribution of the graphite and the nature of the pearlite must be controlled for optimum results. Although there are many hardware applications of these materials because of their machinability they will be discussed in greater detail in later chapters.

#### FREE-MACHINING BRASSES

For applications in which machinability is of importance, 0.2–3.5% lead commonly is added to the copper-base alloys, the lower amounts being used for applications in which considerable formability must be retained even at the sacrifice of some machinability, e.g., forging brass or leaded tubing or sheet. Depending upon the copper contents and the purposes for which the alloys once were used, various names have been given to these leaded alloys such as: *forging*, *free cutting*, *engraver's*, *clock*, *stamping*, *butt*, *matrix*, *tube*, and *free-cutting tube brass*. Even the "bronze" name sometimes is used for them, although, in the true bronzes, tin, not zinc, is alloyed with copper. S.A.E. No. 72 and A.S.T.M. Standard B16 cover a common free-cutting brass rod and bar analysis (60–63% copper, 2.50–3.75% lead, rem. zinc).

<sup>19</sup> See H. W. Graham, *Trans. A.S.M.*, **22**, 1934, 926–940.

<sup>20</sup> See, for example, C. R. Austin and M. C. Fetzer, *Trans. A.I.M.E.*, **145**, 1940, 213–224.

<sup>21</sup> For a further discussion see Ref. 3 at the end of this chapter.

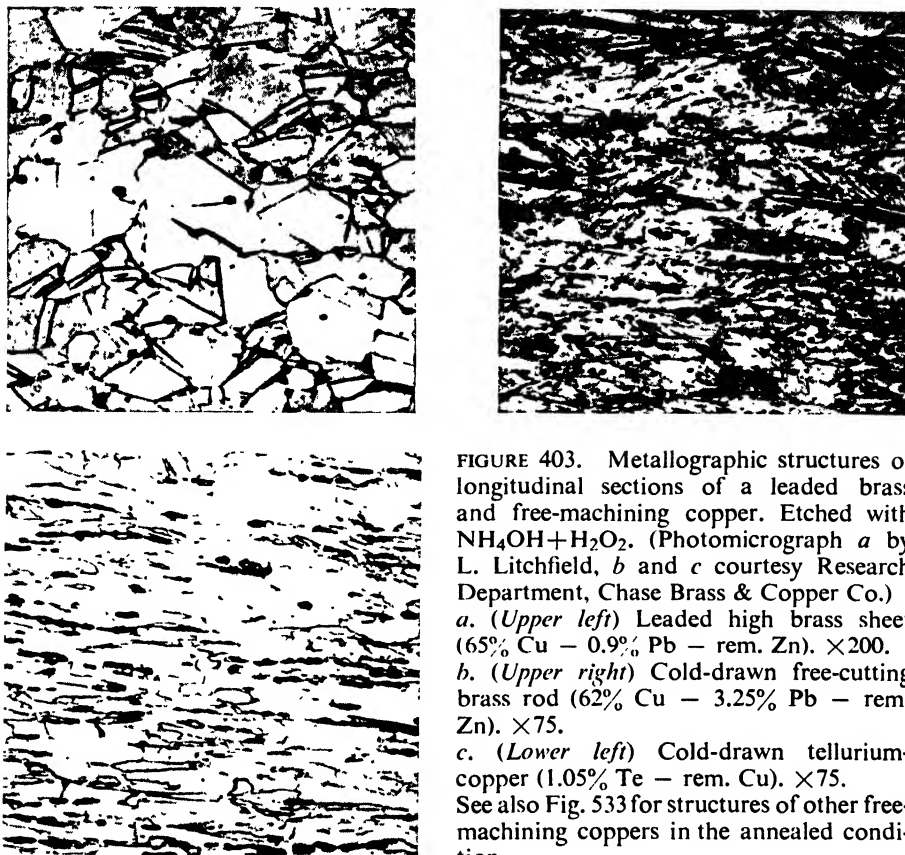


FIGURE 403. Metallographic structures of longitudinal sections of a leaded brass and free-machining copper. Etched with  $\text{NH}_4\text{OH} + \text{H}_2\text{O}_2$ . (Photomicrograph *a* by L. Litchfield, *b* and *c* courtesy Research Department, Chase Brass & Copper Co.)  
*a.* (Upper left) Ledged high brass sheet (65% Cu - 0.9% Pb - rem. Zn).  $\times 200$ .  
*b.* (Upper right) Cold-drawn free-cutting brass rod (62% Cu - 3.25% Pb - rem. Zn).  $\times 75$ .  
*c.* (Lower left) Cold-drawn tellurium-copper (1.05% Te - rem. Cu).  $\times 75$ .  
 See also Fig. 533 for structures of other free-machining coppers in the annealed condition.

The added lead is insoluble in the alloy and appears as small globules scattered throughout the structure (Fig. 403). In small amounts it has little effect on the mechanical properties other than to increase the machinability. The best machining characteristics are secured when the alloys are not in the fully annealed condition since the alpha brasses are ductile enough to make some work-hardening desirable to assist chip breaking.

The machinability of copper or alloys high in copper can also be effectively increased by the addition of up to 1% sulfur, selenium, or tellurium. Like lead, these elements have little effect on the strength, electrical conductivity, or fabricating properties of the alloy although they do reduce the ductility and impact strength appreciably. The microstructures are similar to those of the leaded alloys although the sulfides, selenides, and tellurides, which are the inclusions, show a greater tendency to be elongated in the direction of working, as illustrated in Fig. 403, than the lead does.

## FREE-MACHINING ALUMINUM

Three aluminum alloys, in particular, have machinabilities suitable for automatic screw machine operation. The older Alcoa duralumin-type alloys, *17S-T4*, with the nominal composition 4% Cu – 0.5% Mn – 0.5% Mg – rem. Al, and *24S-T4*, having the nominal composition of 4.5% Cu – 0.6% Mn – 1.5% Mg – rem. Al, have been used most extensively in aircraft, where their higher physical and mechanical properties are required.

However, the newer alloy, developed specifically for automatic screw machine use, *11S-T3* (5.5% Cu – 0.5% Pb – 0.5% Bi – rem. Al), has replaced the older alloys in many applications because of its smaller chips and the fact that it can be machined readily with high speeds and heavy feeds. Both the lead and bismuth serve as insoluble *chip breakers* (Fig. 404), but the copper is present chiefly as a hardening agent. The newer alloy also allows greater flexibility in tool usage than the duralumin-type alloys.

All of these alloys fall within A.S.T.M. Tentative Standard B211-T.

## DIE-CASTING ALLOYS

Because of their melting temperatures and the consequent wear on the dies, die casting has been confined almost entirely to alloys of aluminum, magnesium, lead, tin, or zinc. Of these, the lead and tin alloys have relatively low strengths and are almost all of a bearing nature and hence will be discussed in Chap. XIX as bearing metals. However, they are used to some extent, in competition with other die-casting alloys, particularly for small parts which require good corrosion resistance. The zinc-base alloys are probably most important because of their combination of low cost and good properties. Copper-base alloys are die cast commercially but generally the higher temperatures required introduce many difficulties not encountered with the other alloys. These are the strongest and toughest die-casting alloys.

## ZINC-BASE DIE CASTINGS

Zinc-base alloys are the cheapest of the die-casting alloys and constitute one of the most important uses of this metal. There are three common zinc-base die-casting alloys which are today nearly standard in the industry. These are patented alloys sold under the names *Zamak*<sup>22</sup> and *Dolerzink*,<sup>22</sup>

<sup>22</sup> Registered trade-marks.

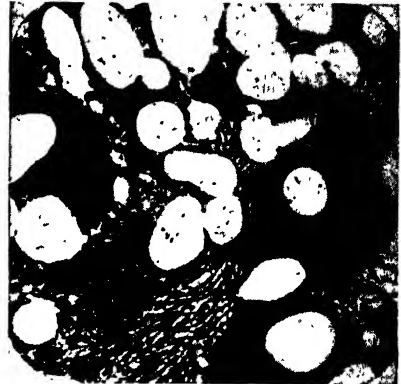


FIGURE 404. (Left) Metallographic structure of free-cutting aluminum alloy, 11S-T3, rod (5.5% Cu - 0.5% Pb - 0.5% Bi - rem. Al). Etched with Keller's reagent, X100. (Photomicrographs courtesy Aluminum Research Laboratories.)

FIGURE 405. (Right) Metallographic structure of A.S.T.M. Alloy XXV (Zamak No. 5), as die cast. Etched with solution containing 5 g CrO<sub>3</sub>, 0.4 g Na<sub>2</sub>SO<sub>4</sub>, 100 ml H<sub>2</sub>O. X1000. (Photomicrograph courtesy Research Division, Technical Department, The New Jersey Zinc Company.)

among others, and are covered by A.S.T.M. Standard B86 as well as by S.A.E. Standards. Typical analyses, in addition to the zinc, will show:

COMPOSITION*	S.A.E. NO. 903† A.S.T.M. NO. XXIII	S.A.E. NO. 921‡ A.S.T.M. NO. XXI	S.A.E. NO. 925§ A.S.T.M. NO. XXV
% Cu	0.10 (max)	2.5 -3.5	0.75-1.25
% Al	3.5 -4.3	3.5 -4.5	3.5 -4.3
% Mg	0.03-0.08	0.02-0.10	0.03-0.08

\* Maximum limits are set for iron (0.10%), lead (0.007%), cadmium (0.005%), and tin (0.005%). The remainder of each alloy is zinc.

† Zamak No. 3, U.S. Pat. No. 1,779,525.

‡ Zamak No. 2, U.S. Pat. No. 1,596,761.

§ Zamak No. 5, U.S. Pat. No. 1,852,441.

The minimum mechanical properties will run, depending upon the alloy:

Tensile strength, psi	35,000-44,000
Elongation, % in 2 in.	2-3
Compressive strength, psi	60,000-93,000
Charpy impact, ft lb	6-12
Brinell hardness (10 mm-500 kg)	74-85

The values for mechanical properties depend both on the alloy and upon



the number of specimens tested, as the variation may be considerable. Hardness tests are not considered to be reliable in these materials.

The copper content governs the specific application to a large extent, the three most important factors to be considered being: (a) the permanency of dimensions required; (b) the tensile strength and hardness; and (c) the impact strength both at room and at elevated temperatures.

The low-copper alloy, S.A.E. 903, is the most permanent with respect to dimensional changes, the maximum change to be expected being 0.001 in. per in., and even this can be reduced by proper heat-treatment. The recommended stabilizing anneal is 4 hr at 212 F (100 C), followed by an air cool or by 4–5 weeks of natural aging. Alloy 925, with intermediate copper, is as good at room temperature but is poorer at elevated temperatures. Alloy 921, with high copper, is inferior to both. On the other hand, alloy 921 has the highest tensile strength and hardness, followed by 925 and 903, but is inferior in retention of impact strength. Alloy 925 has the advantage of a better corrosion resistance than 903.

The metallographic structures of all three of these alloys are similar, although the amounts of the various constituents will vary. In Fig. 405, the structure of the commercial alloy *Zamak No. 5*, which is typical of all of them, is shown. Relatively large white particles of the  $\alpha$  primary solid solution of copper and aluminum in zinc can be seen in a matrix of the eutectic formed by the zinc-rich and aluminum-rich primary solid solution phases,  $\alpha$  and  $\beta$ . Because of this structure and the inherent properties of zinc, the machinabilities of the zinc-base die-casting alloys compare favorably with those of free-machining brass.

#### TESTING OF ZINC DIE CASTINGS

The A.S.T.M. standard test for zinc-base die castings is exposure for a period of 10 days to an atmosphere saturated with water vapor at 95 C (203 F). No undesirable intercrystalline corrosion or growth will take place if the impurity content is kept regulated. Purity and analysis control are very important in these alloys for this reason, and there were many disadvantages to them before this fact was recognized.<sup>23</sup> Lead, tin, and cadmium are especially harmful in this respect so high-grade zinc, which is low in these three impurities, invariably is used for die-casting alloys.

#### ADVANTAGES OF ZINC ALLOYS FOR DIE CASTING

Zinc-base die castings are low in cost and in addition give properties superior to those of most die-casting alloys. They can be die cast readily in

<sup>23</sup> See, for example, H. E. Brauer and W. M. Peirce, *Trans. A.I.M.E.*, 68, 1922, 796.

almost any size or thickness of section, and are readily machinable provided proper tool setups are used. Their corrosion resistance is good, and they are finished readily in a variety of different ways including practically any type of electrodeposit. In addition, their bearing properties are satisfactory for light loads. Many of these characteristics already have been illustrated in Fig. 301.

#### ALUMINUM-BASE DIE CASTINGS

Aluminum-base die castings are almost all alloys of aluminum and copper; aluminum and silicon; aluminum, copper, and silicon, both with and without other additions such as nickel; or aluminum and magnesium. The addition of copper makes the alloys harder, stronger, and less ductile but at the same time lowers the melting point, increases the fluidity, reduces the shrinkage, and also tends to reduce the corrosion resistance to some extent. Silicon gives the alloys a bluish color, and both hardens them and improves their casting qualities without any serious decrease in corrosion resistance. Tool wear is somewhat greater in machining the silicon alloys than with the silicon-free alloys; they are readily machined, however, with tungsten carbide tools. The alloys containing copper have a somewhat better machinability and a brighter color than those containing silicon. Nickel also is added to brighten the color. The ternary aluminum-copper-silicon alloys are an attempt to combine the best properties of both the common alloying elements.

#### IMPURITIES

Aluminum die castings are not particularly sensitive to impurities unless impact strength is desired.<sup>24</sup> Commercial castings frequently contain more than 1% iron, absorbed from the dies and melting pot, but generally an attempt is made to keep the iron below 2%. Alloys made on gooseneck machines usually will pick up more iron than those made in cold-chamber machines because of the inherent natures of the two methods (cf. Fig. 300). Zinc is undesirable as it tends to produce *hot-shortness* in casting so it is kept as low as possible, usually 0.75% max.

Because of these facts aluminum scrap and secondary metal can be used for many aluminum die-casting alloys thus lowering the cost, although, of course, too great a use of low-grade scrap will be reflected in the final analysis and properties. A good idea of the grade of ingot required for the most commonly used aluminum die-casting alloys can be gotten from the conservation chart shown in Fig. 406.

<sup>24</sup> This subject is discussed thoroughly by W. Bonsack, *A.S.T.M. Bulletin*, August 1942, 45-59.

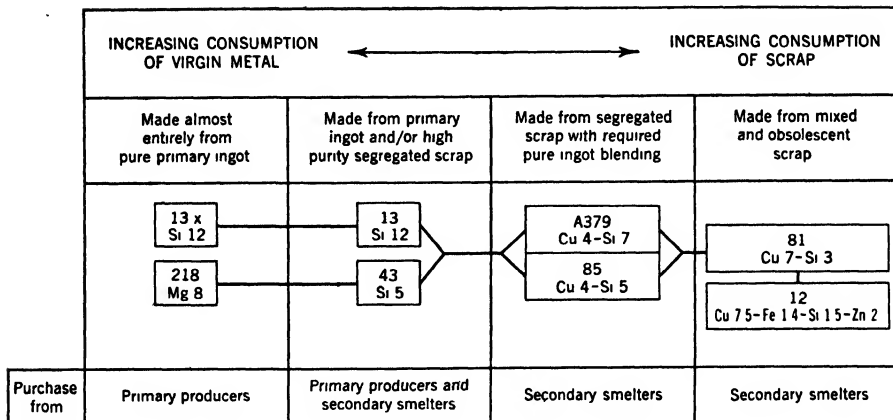


FIGURE 406. Conservation chart for aluminum die-casting alloys. Alloy A379 was a war-time emergency alloy (S.A.E. E306) the use of which has been largely discontinued. Alloys 81 and 12 are low grade and are seldom if ever used for specification castings.

#### COMMERCIAL ALLOYS

Typical analyses of the most widely used commercial aluminum die-casting alloys falling in the three classifications mentioned are listed in Table XXI along with the numerical designations used by the Aluminum Company of America (Alcoa), A.S.T.M. (Tentative Standard B85-T), S.A.E., and the Federal Specification (QQ-A-591). Some of these alloys are available also under the trade names *Doler-Alumin*, *Alculoy*, *Alsiloy*, and *Bohnalite* among others.

TABLE XXI ANALYSES OF TYPICAL ALUMINUM DIE-CASTING ALLOYS

ALCOA NO.	Designation			Composition		
	A.S.T.M. B85-T	S.A.E.	FEDERAL QQ-A-591	% CU	% SI	% MG
43	S4	304	3	—	5	—
13*	S5	305	1	—	12	—
85*	SC2	307	5	3.5	5	—
380*	SC7	308	11	3.5	8.5	—
81	—	—	4	7	3	—
360*	SG3	—	—	—	9.5	0.5
218	—	—	7	—	—	8

\* The specifications also include grades of each of these alloys which are made with the same nominal composition but with impurities, especially iron, more closely controlled.

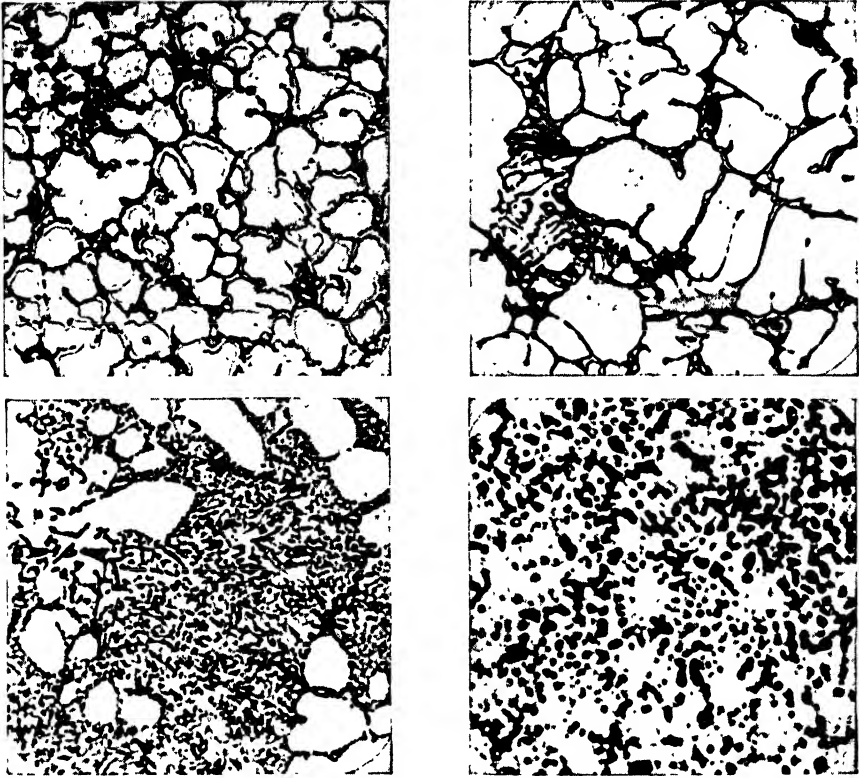


FIGURE 407. Metallographic structures typical of aluminum die-casting alloys.  $\times 500$ . (Photomicrographs courtesy Aluminum Research Laboratories.)

- a.* (Upper left) 85 Alloy (4% Cu - 5% Si - rem. Al). Etched with Keller's reagent.  
*b.* (Upper right) 81 Alloy (7% Cu - 3% Si - rem. Al). Etched with Keller's reagent.  
*c.* (Lower left) 13 Alloy (12% Si - rem. Al). Etched with  $\frac{1}{2}\%$  HF.  
*d.* (Lower right) 218 Alloy (8% Mg - rem. Al). Etched with Keller's reagent.

The structures of some of these alloys are shown in Fig. 407, all of them rather fine because of the rapid cooling. The structures of 85 and 81 are similar, consisting essentially of a small amount of  $\theta(\text{CuAl}_2)$  and silicon, possibly in a finely dispersed eutectic form, at the boundaries of an aluminum-rich solid solution matrix. The structure of 13 consists of cells of aluminum primary solid solution in the eutectic mixture of aluminum and silicon, and that of 218 of particles of  $\alpha(\text{Al-Mg})$  secondary solid solution in an aluminum-rich primary solid solution matrix. The structure of 380 would resemble those of 85 and 81, and the structures of 43 and 360 that of 13 although with smaller amounts of the eutectic mixture.

Several different types of finishes are used on these alloys, some of which, such as electroplating and anodizing, permit marked changes in appearance and color.

All of the pressure-cast alloys shown possess average tensile strengths, measured from A.S.T.M. standard unmachined round die-cast specimens, in the range 29,000–45,000 psi with elongations of 1–7% in 2 in., and Charpy impact values on square specimens of 2–5 ft lb. Except for 218, which is the lightest alloy and has the highest impact strength of all the aluminum die-casting alloys listed, alloy 85 has the best combination of strength and ductility and is used widely as an inexpensive general-purpose alloy, especially where heavy sections must be cast. Specific gravities may vary between 2.65 and 2.85 depending upon the alloy. Similar compositions frequently are used for permanent mold castings.

#### MAGNESIUM-BASE DIE CASTINGS

Magnesium-base die-casting alloys have about the same mechanical properties as aluminum alloys, are cast at the same temperatures, and can be cast in the same dies. In addition they are about two thirds the weight of aluminum-base and one quarter the weight of zinc-base die castings. Therein lie their chief advantages, although they also possess excellent casting characteristics, and, with proper tools, they can be machined at more than twice the speed of free-cutting brass bar stock and at more than four times the speed of cast iron.

Two alloys are in general use, both of them covered either by A.S.T.M., Tentative Standard B94-T or by S.A.E. Standards. Aluminum is the most effective element for improving the general properties and casting characteristics of magnesium. Manganese is present, in amounts approximating its solubility in the liquid alloys, in order to improve the corrosion resistance, even though it has relatively little effect on the other properties. Copper and nickel must be kept to a minimum because of their deleterious effects on the corrosion resistance.

S.A.E.	A.S.T.M. B94-T	DOW CHEMICAL COMPANY	AMERICAN MAGNESIUM CORPORATION	% AL	% MN (MIN)	% ZN (MAX)	% SI (MAX)
—	AS100	<i>K</i>	<i>AM230</i>	9–11	0.10	0.3	1.0
501	AZ90	<i>R</i>	<i>AM263</i>	8.3–9.7	0.13	0.4–1.0	0.5

Of the two, A.S.T.M. AZ90 is considered to have the best combination of casting qualities, mechanical properties, and corrosion resistance.

The average mechanical properties of these alloys are somewhat similar, and fall within the ranges:

Tensile strength, psi	29,000–34,000
Yield strength (0.2% dev. from mod. line), psi	22,000–20,000
Elongation, % in 2 in.	1–3
Izod impact, ft lb	1–2
Charpy impact, ft lb	0.5–3
Brinell hardness (10 mm–500 kg)	68–66

The alloys tend to darken on exposure to the atmosphere because of the formation of an oxide film, and are especially poor in moist or sea atmospheres. Hence, for best results, they are protected by some sort of finish, preferably by painting or lacquering as electroplating of these alloys is just becoming commercially possible and still is used only for indoor service.

A metallographic structure typical of the magnesium-base die-casting alloys is illustrated in Fig. 408. In the dendritic matrix of magnesium-rich solid solution are patches of an aluminum-magnesium secondary solid solution ( $Al_2Mg_3$ ), the exact composition of which is somewhat controversial. This secondary solid solution may appear as a massive light-etching phase or, if precipitated from liquid solution by chill casting as in the figure shown, as a lamellar constituent, similar in appearance to pearlite in steel. This phase also may contain zinc if any is present. In addition, magnesium silicide ( $Mg_2Si$ ) also may be present depending on the silicon content. This  $Mg_2Si$  constituent may vary in color from a powder blue to an iridescent blue-green.

#### COPPER-BASE DIE CASTINGS

The high melting points of the copper-base alloys have made it very difficult to secure dies which will be resistant enough to the temperatures required to make many die castings economically possible although these alloys have been die cast commercially for several years. The most common troubles arise from surface cracks or checks.

Some copper analyses can be made from remelted scrap, thus getting metal at a substantially lower cost. Although the yellowish color of these alloys is a definite disadvantage if plated finishes are to be used, they have higher strengths and greater ductility and hardness than other die-casting alloys. The brass alloys used most commonly are modifications of a stand-

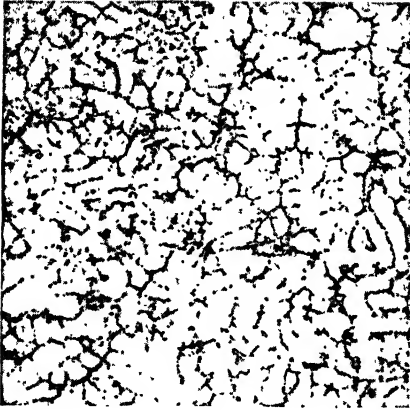


FIGURE 408. Metallographic structure of die-cast Dowmetal R (9% Al — 0.2% Mn — 0.6% Zn — rem. Mg). Etched 5 sec in glycol etchant.  $\times 250$ . (Photomicrograph courtesy The Dow Chemical Company.)

tensile strengths exceeding 45,000–58,000 psi, and yield strengths of 25,000–30,000 psi, although their elongations are higher, averaging 10–15% in 2 in. or better.

ard Muntz metal (60% Cu–40% Zn) composition, usually with added tin to increase strength, and added lead to increase machinability. Some aluminum and manganese frequently are added to increase flowability.<sup>25</sup> Seven of the commonest alloys contain, nominally, the elements indicated in Table XXII.

The first and third alloys are covered by A.S.T.M. Tentative Standard B176-T.

With the high copper-silicon alloys ultimate strengths of as high as 105,000 psi, with yield strengths of 60,000 psi, and elongations of 5% in 2 in. can be secured. The 60:40 alloys are much weaker, however, with average

TABLE XXII NOMINAL CHEMICAL COMPOSITIONS OF SOME COMMON COPPER-BASE DIE-CASTING ALLOYS

	% CU	% ZN	% NI	% SN	% AL	% PB	% MN	% SI	% FE
<i>Yellow brass</i>	57†	30†	—	1.5*	0.25*	1.5*	0.25*	0.25*	0.25*
<i>Yellow brass</i>	58	41	—	1.5*	0.1*	0.4*	0.25*	—	2*
<i>Doler-brass #1‡</i>	65	34	—	—	—	—	—	1	—
<i>Doler-brass #5‡</i>	83	10	—	—	1	—	1	5	—
<i>Brastil (Doler-brass #4)‡</i>	81.5	14	—	—	—	—	—	4.5–5	—
<i>Tinicosil‡</i>	42	41	16	—	—	1	—	—	—
<i>Manganese bronze</i>	55–60	40	—	1.5*	1.5*	0.4*	3.5*	—	2*

\* Max † Min ‡ Registered trade-marks.

The metallographic structure of the alloys is illustrated in Fig. 409. The major constituents of *Tinicosil* are the light etching  $\alpha$  primary solid solution of copper, zinc, and nickel in a finely dispersed eutectoid of  $\alpha$  and the  $\beta$  secondary solid solution of these three components. Inclusions of insoluble lead also can be found if this element is present. The structures of the other

<sup>25</sup> See, also, J. R. Freeman, Jr., *Trans. A.I.M.E.*, 117, 1935, 371–377.

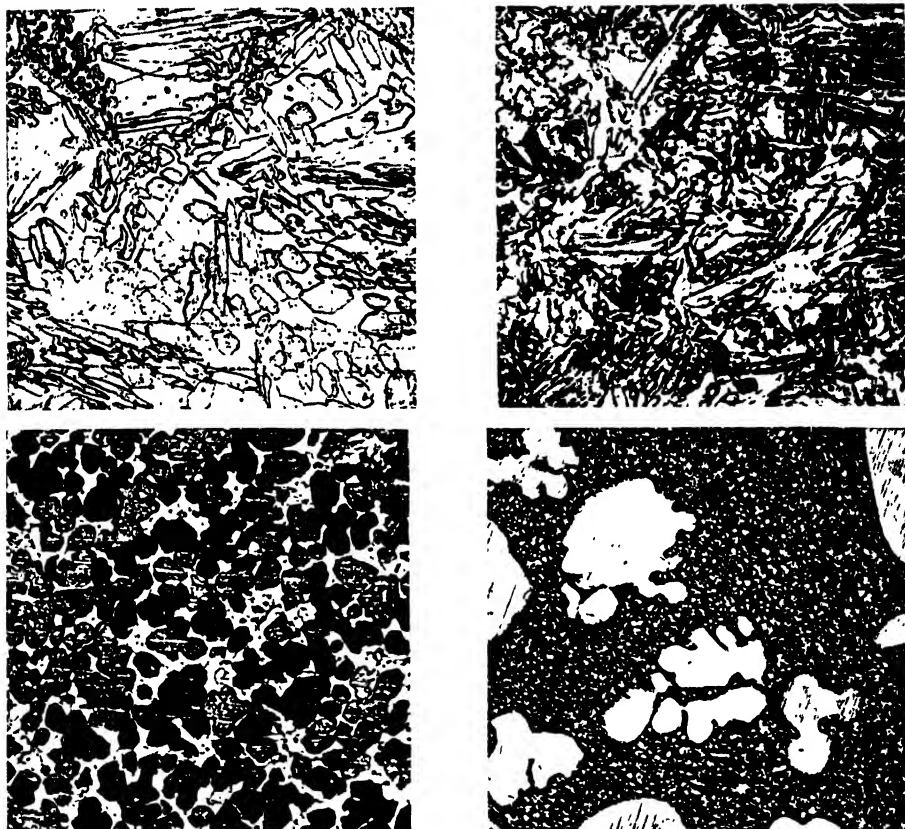


FIGURE 409. Metallographic structures of typical commercial copper-base die-casting alloys.

*a.* (Upper left) Doler-Brass #1 (65% Cu — 1% Si — 34% Zn). Etched with  $\text{NH}_4\text{OH} + \text{H}_2\text{O}_2$ .  $\times 500$ .

*b.* (Upper right) "F" alloy (60% Cu — 0.5% Sn — 0.5% Pb — 39% Zn). Etched with  $\text{NH}_4\text{OH} + \text{H}_2\text{O}_2$ .  $\times 500$ .

*c.* (Lower left) Doler-Brass #4 (81% Cu — 4.5% Si — 14.5% Zn). Etched with 15% ammonium persulfate.  $\times 500$ .

*d.* (Lower right) Tinicosil (42% Cu — 16% Ni — 1% Pb — 41% Zn). Etched with potassium dichromate solution.  $\times 200$ .

(Photomicrographs *a, b, c*, courtesy Doehler Die Casting Co.; *d*, courtesy Titan Metal Mfg. Co.)

alloys are those of normal alpha-beta brass (cf. Figs. 306 and 413), although the amount of  $\beta$  constituent in the silicon brasses is much less, and possibly of a different type than that in the 60:40 Muntz metal modifications.

#### PEWTER

The pewters are a group of tin-base alloys, containing varying amounts of antimony, lead, copper, and zinc. Both their appearance and their re-



sistance to tarnish are good; and they once were used extensively for table utensils, although they are not so popular today as formerly.

Although the original alloy contained only tin and lead, a popular suspicion of lead contamination of foodstuffs from it caused a change to a composition consisting almost entirely of tin but containing up to 8% antimony and up to 3% copper, which appears as a hard copper-tin compound, as hardeners. Somewhat more antimony and considerable lead also still are used at times, but the compositions and structures of the usual pewters resemble those of the tin-base bearing metals.

The alloy *Britannia metal*, as made today, is really a variety of pewter.

### *For Further Study Refer to*

1. *Metals Handbook*: American Society for Metals, Cleveland, Ohio, 1939 (usually published triennially). A new edition will appear in 1948.
2. *Modern Uses of Non-Ferrous Metals*, edited by C. H. Mathewson: American Institute of Mining and Metallurgical Engineers, New York, 1935.
3. *Machining of Metals*: American Society for Metals, Cleveland, Ohio, 1938.
4. *Die Castings*, by H. Chase: John Wiley & Sons, Inc., New York, 1934.
5. *Die Castings*, by A. Street: Emmott & Co., Ltd., London, 1939.
6. *The Machining of Copper and Its Alloys*: Copper Development Assoc., London.
7. *Copper Steels to Resist Corrosion*: Copper Development Assoc., London.
8. *Sheet Copper Work for Building*: Copper Development Assoc., London.
9. *The Book of Stainless Steels*, edited by E. E. Thum: American Society for Metals, Cleveland, Ohio, 1935.
10. *Copper and Copper Base Alloys*, by R. A. Wilkins and E. S. Bunn: McGraw-Hill Book Company, Inc., New York, 1943.
11. *Die Casting for Engineers*: The New Jersey Zinc Co., New York, 1942.
12. *Alcoa Aluminum and Its Alloys*: Aluminum Company of America, Pittsburgh, Pa., 1947.
13. *Designing with Magnesium*: American Magnesium Corporation, Pittsburgh, Pa., 1943.
14. *Properties of Magnesium Products*: American Magnesium Corporation, Pittsburgh, Pa., 1943.
15. *High Pressure Die Casting, A Design Guide for Engineers*, by H. L. Harvill and Paul R. Jordan: H. L. Harvill Mfg. Co., Vernon, Cal., 1945.

16. *Metal Progress*: American Society for Metals, Cleveland, Ohio (published monthly).
17. *Materials and Methods* (formerly *Metals and Alloys*): Reinhold Publishing Corporation, New York (published monthly).
18. Publications of:
  - Aluminum Company of America, Pittsburgh, Pa.
  - American Brass Co., Waterbury, Conn.
  - American Magnesium Corporation, Cleveland, Ohio.
  - American Rolling Mill Co., Middletown, Ohio.
  - Anaconda Copper Co., New York, N. Y.
  - Bethlehem Steel Co., Bethlehem, Pa.
  - Bridgeport Brass Co., Bridgeport, Conn.
  - Chase Brass & Copper Co., Waterbury, Conn.
  - Dow Chemical Company, Midland, Mich.
  - International Nickel Co., Inc., New York, N. Y.
  - Kennecott Copper Co., New York, N. Y.
  - National Lead Co., New York, N. Y.
  - New Jersey Zinc Co., New York, N. Y.
  - Permanente Metals Corp., Oakland, Cal.
  - Republic Steel Corp., Cleveland, Ohio.
  - Revere Copper and Brass Co., New York, N. Y.
  - Reynolds Metals Co., Louisville, Ky.
  - Scovill Mfg. Co., Waterbury, Conn.
  - Seymour Mfg. Co., Seymour, Conn.
  - U. S. Steel Corporation, New York, N. Y.
  - Wheeling Steel Corp., Wheeling, W. Va.

## Pipe, Tubing, and Castings Resistant to Water Corrosion

### FERROUS MATERIALS

THE PRINCIPAL FERROUS MATERIALS USED PRIMARILY FOR resisting water corrosion, especially in the form of pipe, are wrought iron and mild steel, although certain mild alloy steels, such as the copper-bearing steels, are also suitable. Cast iron is the metallic material used most widely for water main, drain, and soil pipe, for under most conditions its corrosion resistance is greater and its cost lower than that of steel.

In general, ferrous materials are apt to be considered undesirable because of their tendency to rust. Frequently this imparts a brown stain to the water and sometimes results, in severe cases, in complete clogging of the pipe. The seriousness of the corrosion for any particular application, however, cannot be determined readily except by actual trial; and in many instances the ferrous materials will be entirely satisfactory, outlasting even many supposedly superior nonferrous alloys.

Corrosion is generally less if dissolved oxygen is kept to a minimum or if inhibitors, such as silicates, chromates, phosphates, and large molecule organic compounds like tannins and urea, can be used. In boiler corrosion an intercrystalline caustic embrittlement sometimes occurs. This always is associated with a high alkalinity of the water regardless of whether this is natural or is the result of a softening treatment. Waters containing relatively high carbonate combined with relatively low sodium sulfate concentrations<sup>1</sup> are especially bad. The sodium carbonate decomposes in the boiler to give sodium hydroxide and the combination of this with the high stresses in certain parts of the boiler leads to intercrystalline failure as illustrated in Fig. 410*a*. If the ratio of sodium sulfate to sodium carbonate is kept high enough, depending on the pressure used, this trouble can be prevented. Boiler steels, however, often are subject also to failure from corrosion

<sup>1</sup> For a complete discussion see report in *Journ. Iron & Steel Inst.*, London, **143**, 1941, 93-158.

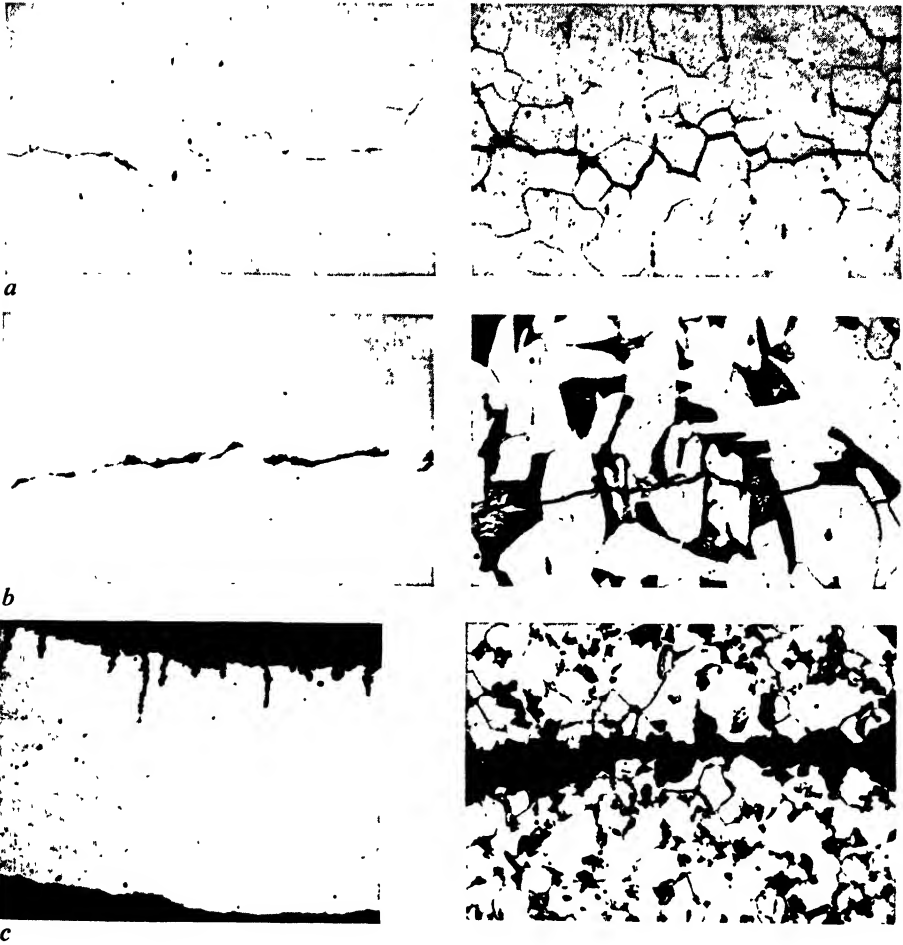


FIGURE 410. Metallographic appearance of boiler plate that has failed because of various types of corrosion.

*a.* Caustic embrittlement. Unetched and etched with 2% picral.  $\times 150$ . Note that the fracture is definitely intercrystalline.

*b.* Corrosion fatigue. Unetched and etched with 4% nital.  $\times 250$ . This fracture definitely passes through the grains, i.e., is transcrystalline.

*c.* Stress corrosion. Unetched,  $\times 8$ , and etched with 4% nital,  $\times 500$ . This fracture also is largely intercrystalline.

(Photomicrographs courtesy The Babcock & Wilcox Co.)

fatigue (Fig. 410*b*), and stress corrosion (Fig. 410*c*). Cracks resulting from the former cause are transcrystalline and hence a careful examination will differentiate them readily from the intercrystalline cracks resulting from caustic embrittlement. Cracks resulting from stress corrosion, however, are also intercrystalline.

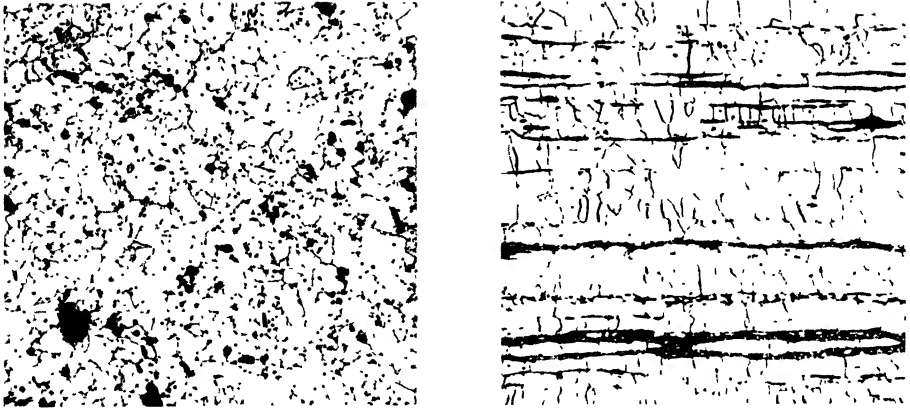


FIGURE 411. Metallographic structures of wrought iron. Etched with nital.  $\times 100$  originally; reduced about one half in reproduction. *a.* (Left) Transverse. *b.* (Right) Longitudinal. (Photomicrographs courtesy A. M. Byers Company.)

Good quality wrought iron is characterized by a high-purity ferritic base metal and well-distributed slag fibers. The shape of the fibers, in either section, depends upon the manner in which the piece was rolled.

#### WROUGHT IRON

The time-tested metal wrought iron still is extensively used because of its resistance to corrosion, especially that of the atmosphere and various types of water, and to fatigue. A typical analysis of this material will show:

	% C	% MN	% P	% S	% SI	% SLAG (WGT)
Combined Analysis	0.02	0.03	0.12	0.02	0.15	3.00
Separate Analysis	Base metal	0.02	0.01	0.10	0.02	—
	Slag	—	0.02	0.02	—	0.14

The phosphorus content, which may run higher than 0.25%, is largely responsible for the good corrosion resistance of this material.

The alloy usually is worked hot and will have structures similar to those shown in Figs. 126 and 411. Because of the elongation of the slag fibers during rolling, the transverse and longitudinal sections will usually differ in appearance even though in either section the ferrite grains will be essentially equiaxed and the slag may have a ribbonlike appearance. Abnormal grades in which refining was incomplete or in which considerable steel scrap was bundled in with the wrought iron may have mi-

crostructures showing an appreciable amount of pearlite banding with somewhat higher strengths and somewhat poorer corrosion resistance. Metallographic structures typical of these may be seen in Fig. 127.

The physical properties of wrought iron usually will not be superior to those of the ingot irons, unless some alloying elements are present. Typical minimum values would approximate:

Tensile strength, psi	48,000
Yield point, % of T.S.	60
Elongation, % in 8 in.	25
Reduction in area, %	40
Brinell hardness (10 mm – 500 kg)	97–105
Rockwell hardness ( $1\frac{1}{6}$ –100–B)	B55–60

The properties may vary considerably depending upon the amount of refining during manufacture, the size of section, and the exact composition. It is very probable, in fact, that most of the superior properties of wrought iron result from its phosphorus content and that it really should be considered as an iron-phosphorus alloy containing admixed slag particles.

Some additional protection against corrosion may be given by galvanizing or by the black oxide coating formed during hot-working.

Some typical specifications covering wrought iron are:

A.S.T.M.: A42 (Plates), A72 (Welded Pipe), A73 (Blooms and Forgings), A84 and A86 (Staybolts), A152 (Rivets), A189 (Bars), and A207 (Structural Shapes and Bars), as well as several others.

A.S.M.E.: S-19 (Welded Pipe), S-16 (Boiler, Rivet, Staybolts).

A.S.A.: B36.2 (Welded Pipe), G23 (Uncoated Sheets).

Federal: WW-P-441 (Welded Pipe), QQ-I-686a (Bars).

U. S. Navy: 44-P-11g (Pipe), 56-I-7a (Bars).

Wrought iron is used with all kinds of mildly corrosive liquids, such as hot and cold water, air, gas, oil and gasoline, many refrigerants, salt waters and brines. It also has some structural applications in the form of plates, reinforcing bars, staybolts, tanks, etc., although in much of this work it has been replaced by the less expensive steels.

#### MILD STEEL AND CAST IRON

Steel pipe is made of a typical mild steel similar to that which has already been discussed in Chap. XIII. When used for pipe or tubes this alloy may be covered by A.S.T.M. Standards A155, A161, A178, or A179, among others. Like wrought iron, mild steel pipe also is supplied with either a *black* (oxidized) or a *galvanized* finish, the latter having the

better corrosion resistance. The addition of about 0.25% copper and/or about 0.50% molybdenum is supposed to be very beneficial especially if temperatures somewhat above atmospheric are used.

Gray cast-iron pipe is extensively used with ordinary mildly corrosive waters especially in water, drain, and soil pipes, and similar installations where the corrosive conditions are not severe and somewhat larger diameters and wall thicknesses can be used than customarily are employed for household plumbing. Even though its corrosion rate might be expected to be much greater than that of iron or steel because of its comparatively low purity and heterogeneous structure, the skin found on the surface of most iron castings is fairly resistant to corrosion. In addition, the greater thickness of the usual cast-iron pipe is advantageous because it gives a larger factor of safety. Small amounts of nickel, chromium, or copper are sometimes added to increase corrosion resistance and denseness, especially in applications involving pressure. Commercial gray iron for some typical applications will analyze, on the average:

	% SI	% C	% S	% P	% MN	% NI	% CR	% CU
Water pipe	1.6	3.5	0.08	0.5	0.5	—	—	—
Soil pipe	2.2	3.7	0.08	0.1	0.6	—	—	—
Oil-refinery pipe	1.5	3.5	0.08	0.7	0.6	0.2	0.3	—
Oil-refinery pipe	1.7	3.5	0.08	0.7	0.6	—	—	0.8
Caustic pots, plain	1.0	3.6	0.07	0.2	0.7	—	—	—
Caustic pots, alloy	0.7	3.5	0.11	0.2	0.5	2.5	0.4	—

#### COPPER AND BRASS PIPE

*Copper, red brass* (85% Cu–15% Zn), *2 and 1 yellow brass* (67% Cu–33% Zn), and *Muntz metal* (60% Cu–40% Zn) all are used to combat water corrosion to some extent, even though they all have certain advantages and disadvantages. Depending on the specific application, these alloys may fall within the limits of any of several similar A.S.T.M. and S.A.E. Standards.

Copper and the first two alloys fall within the  $\alpha$  solid solution range, and hence, being single-phase alloys, tend to have a somewhat greater corrosion resistance than the two-phase,  $\alpha$ - $\beta$ , Muntz metal. However, all brasses, and especially those containing less than about 80% copper, are susceptible to *dezincification* in which the alloy first dissolves and the

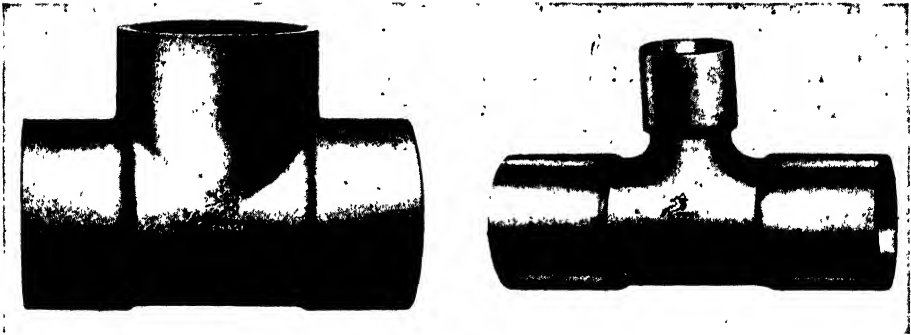


FIGURE 412. Typical tee fittings used with copper water tubing. Cast (*left*); wrought (*right*). (Courtesy Chase Brass & Copper Co.)

copper immediately reprecipitates in a spongy porous mass. This is discussed in more detail in Chap. XI. In the yellow brasses this attack is frequently of a *plug type*, affecting only a small region in a long length of pipe in service. Thus, the lower cost Muntz metal, in which dezincification is usually of a *general or uniform type*, frequently will outlast a more expensive yellow brass pipe which might fail at only one spot, but thus is rendered useless. This tendency toward dezincification may be decreased by the addition of small amounts (about 0.03%) of arsenic, antimony, or phosphorus to the alloy.<sup>2</sup>

Red brass is practically immune to dezincification and resists pitting somewhat better than copper, although, because of their higher copper content, both of these alloys are appreciably more expensive than the other two mentioned.

*Arsenical coppers*, containing up to 0.5% arsenic, sometimes are used for tubing, especially when the metal is exposed to moderate temperatures. These alloys have a fairly high conductivity with somewhat better mechanical properties and a higher softening temperature than ordinary deoxidized copper (cf. Fig. 61). Their use is dictated largely by their good resistance to oxidation at moderate temperatures.

Copper also is made in the form of a flexible water tubing employing compression or soldered fittings, similar to those illustrated in Fig. 412, and thus permitting a much thinner wall than would be possible with the more conventional threaded joints. This method of assembly permits a lower cost for equally satisfactory material since failure and leaking of standard pipe usually occur at the screw thread rather than in the body of the pipe. Copper tubing, because of its flexibility, is also very convenient for replacing plumbing in houses already constructed.

<sup>2</sup> See for example, W. Lynes, *A.S.T.M. Preprint No. 44*, 1941, 1-21; *Met Ind.*, 59, 1941, 274-277, 297-300.



Up to 0.5% lead may be added to any of the alloys, to facilitate threading and other machining operations, without interfering seriously with their general workability.

Copper-base alloys tend to give a greenish blue corrosion product and with many types of water this will either discolor the water, which some people like to term "green water trouble," or else give a blue stain or deposit wherever dripping occurs. The nature of the water to be used should be known, therefore, before the metal for carrying it is selected. Otherwise much trouble and inconvenience may result because plumbing cannot conveniently be replaced if found to be unsatisfactory after construction is completed. In hot-water lines, in particular, extreme care must be used in selecting the proper alloy, because the higher temperature is ideal for causing discoloration and/or dezincification with certain types of water. In problems of this sort it is better always to consult the manufacturer of the pipe or tubing rather than to proceed in other ways. The manufacturer probably will have had sufficient experience with the specific conditions to recommend the alloy which will give best results.

#### MUNTZ METAL

The  $\alpha$ - $\beta$  two-phase brass alloys, of which Muntz metal is a typical example, contain 55–61% copper with the balance essentially zinc, and are yellow in color but with a definite reddish cast. The alloys hot-work readily in the range 1150–1400 F (625–750 C), but have only fair cold-working characteristics because of the influence of the relatively brittle  $\beta$  constituent. The machinability of the alpha-beta brasses generally is better than that of the nonleaded alpha brasses. This is largely attributable to the increased brittleness imparted by the  $\beta$  constituent, which assists the chip formation materially.

Muntz metal, nominally 60% Cu–40% Zn, is about the only alpha-beta alloy of much commercial importance which contains only copper and zinc. It is used for architectural work, valve stems, condenser tubes and plates, brazing rods, and many other applications where the ease with which it can be hot-extruded and hot-rolled simplifies fabrication. This alloy is covered by A.S.T.M. Standards B111 (Condenser Tubes and Ferrules), B124 (Forging Rods, Bars, and Shapes), and B171 (Condenser Tube Plates), and S.A.E. No. 74 also includes it.

The appearance of the constituents in the metallographic structure depends on the etchant used. With the usual ammonium hydroxide-hydrogen peroxide solution, the  $\alpha$  grains stand out in a matrix of lemon-yellow colored  $\beta$  (Fig. 413a), from which they formed on cooling. If a ferric chloride

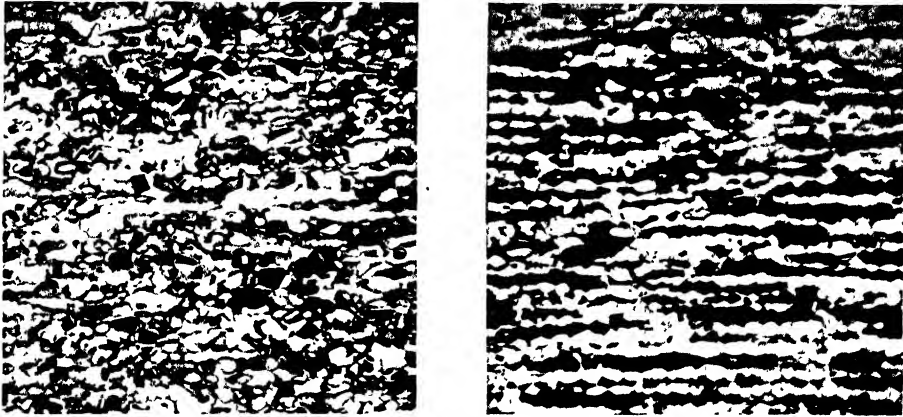


FIGURE 413. Metallographic structure of Muntz metal (60% Cu — 40% Zn).  $\times 75$ . Cf. Fig. 214a and b, and Fig. 306.

a. (Left) Etched with  $\text{NH}_4\text{OH} + \text{H}_2\text{O}_2$ ,  $\beta$  constituent is lemon yellow.

b. (Right) Etched with ferric chloride solution,  $\beta$  constituent is darkened.

(Photomicrographs courtesy Research Department, Chase Brass & Copper Co.)

solution is used, however (Fig. 413b), the  $\beta$  darkens without any appreciable change in the appearance of the  $\alpha$ . This method may be used for differentiating between the two constituents. In addition, annealing twin bands may appear in the  $\alpha$  if it previously has been deformed at all but never are found in the  $\beta$  constituent. Figs. 210 and 306 show several of the structural variations that can be secured with this alloy.

In the hot-rolled condition Muntz metal will have a tensile strength of about 55,000 psi, with a yield strength (0.5% elongation in 2 in. under stress) of 20,000 psi, and an elongation of 45%. In this condition, the Rockwell hardness will be about F80. By cold-rolling, the tensile strength can be raised to about 80,000 psi and the yield strength to 60,000 psi, but the elongation will decrease to about 5%.

#### SPECIAL BRASSES

For condenser tubing, especially for use with salt water, the corrosion resistance of the ordinary brasses seldom is good enough. Hence, a series of special or alloy brasses has been developed to give improved corrosion resistance. Some of the more important of these are *admiralty metal*, *aluminum brass*, *naval brass*.

#### ADMIRALTY METAL

One of the better of the low-cost condenser-tube alloys originally was developed by the British Admiralty and since has been used extensively.

As usually specified, it has a composition of not less than 70% copper, 0.90–1.20% tin, not over 0.075% lead, not over 0.06% iron, and the remainder zinc. In the soft condition, this material will develop a tensile strength of 50,000 psi minimum, with a yield strength (0.5% elongation in 2 in. under stress) of 23,000 psi, and an elongation of 60–75% in 2 in. The alloy machines satisfactorily at moderate speeds provided high-speed steel or carbide tools are used. It has shown satisfactory resistance to sea-water corrosion, although sometimes it fails by dezincification. To resist this, small amounts of arsenic, antimony, or phosphorus usually are added, and sometimes both surfaces of the tube are tinned. Applying to this alloy are A.S.T.M. Standards B111 (Condenser Tubes and Ferrule Stock) and B171 (Condenser Tube Plates) as well as U. S. Navy Specification 44-T-7f and Federal Specification WW-T-756. Up to about 1500 F (800 C) the tin is in solid solution and, therefore, the microstructure of the wrought alloys is similar to that of a 70:30 brass.

British and American usage with this alloy differ. The British commonly use a hard-drawn tube which, they claim, resists mechanical forms of attack, air impingement, and erosion somewhat better than the finish-annealed American tubes. However, the softer and more uniform American tubes probably are more resistant to chemical and electrochemical corrosion and to stress-corrosion cracking than the hard-drawn tubes, although no general agreement on any of these points seems to exist.

#### ALUMINUM BRASSES

Up to 2% aluminum has been added to the 70:30 brass alloy with interesting results. These aluminum brasses have been used extensively in this country in recent years, especially for marine condenser tubes. The most commonly used alloy contains 76% copper, 2% aluminum, a maximum of 1.25% tin and 1.25% nickel and the remainder zinc. When inhibitors, such as arsenic or antimony, are added, this alloy resists dezincification very well. The composition is covered by A.S.T.M. Standard B111 for Condenser Tubes and Ferrule Stock.

The aluminum tends to form a thin, self-healing film of aluminum oxide on the surface of the tube, thus increasing the resistance to air impingement attack, an important factor in marine condensers and those stationary condensers which are on the seacoast handling salt water. However, the aluminum brasses are more difficult to fabricate than the simpler alloys, and have been used extensively only since tube extrusion became common practice in the brass industry.

The metallographic structures are similar to those of the straight brasses because tin, nickel, and aluminum are all soluble in brass in the amounts used.

#### NAVAL BRASS

The addition of 1% tin to a Muntz metal base gives an alloy which has a similar microstructure but somewhat better corrosion resistance and mechanical properties than those of the straight copper-zinc alloy. The alloy is also sold under the trade names of *naval brass*, *Chamet Bronze*,<sup>3</sup> *Roman Bronze*,<sup>3</sup> and *Tobin Bronze*<sup>3</sup> among others. This alloy is used principally for marine applications when a comparatively high strength is needed in combination with a good corrosion resistance and at a fairly low cost. Leaded varieties with improved machinability also are available commercially. S.A.E. No. 76 is of this type, and A.S.T.M. Tentative Standard B21-T (Rods, Bars, and Shapes) and Standard B171 (Condenser Tube Plates) cover it also.

#### CUPRONICKEL

The copper-rich alloys containing 2.5–30% nickel in solid solution are known as the cupronickels. The compositions used most commonly are 95% Cu–5% Ni, 80% Cu–20% Ni, and 70% Cu–30% Ni. The last alloy is sometimes called *Supernickel*.<sup>3</sup> All of the alloys can be worked readily and heavily provided comparatively small percentage reductions per pass are given. However, because of the relatively low rates of homogenization it sometimes is difficult to eliminate the severe coring which is characteristic of the “as cast” structures (Fig. 414a). After homogenization by a series of hot-working or cold-working and annealing operations, the metallographic structure of all of them is similar to that of a typical copper-base solid solution alloy as illustrated in Fig. 414b. A certain amount of care in annealing is required to prevent fire cracking and to minimize excessive oxidation as well as attack by furnace gases; bright annealing is definitely preferable. As the nickel content increases, the hardness and strength increase and the workability and electrical conductivity decrease, as would be anticipated (cf. Fig. 188).

These cupronickel alloys are much more resistant than copper to corrosion by most types of atmospheres, natural and industrial waters, and sea water, as well as many mineral and organic acids. Because of their nickel content they show also good resistance to attack by alkalis.

<sup>3</sup> Registered trade-marks.

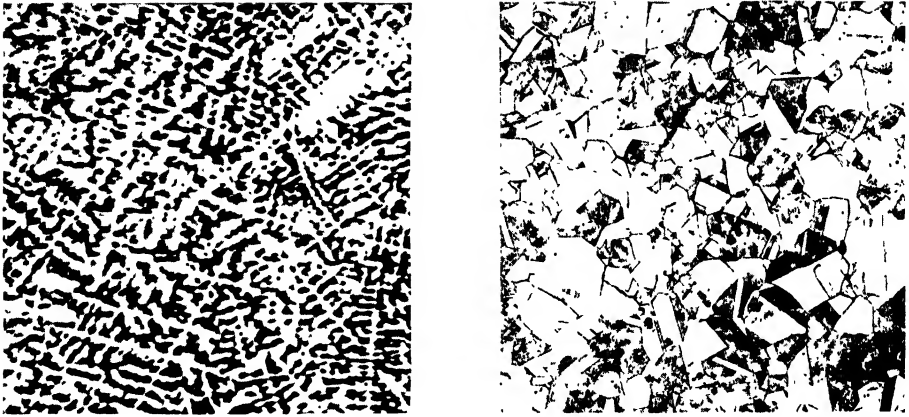


FIGURE 414. Metallographic structures of 70:30 cupronickel (70% Cu — 30% Ni). *a.* (Left) As cast.  $\times 50$ . *b.* (Right) Worked and annealed.  $\times 100$ . Etched with Gard's No. 1 (0.5 g  $\text{FeCl}_3$ , 50 ml HCl, 100 ml  $\text{H}_2\text{O}$ ).

The cupronickels are used for parts where resistance to corrosion and erosion is required, such as turbine blades and condenser tubes, especially with salt water, and containers for handling corrosive substances in the chemical industries. The 80:20 and 70:30 alloys fall within the limits of A.S.T.M. Standard B111 for Condenser Tubes and Ferrule Stock. Products made of this alloy are fairly expensive but usually this is counterbalanced by their dependability and increased service life.

A cast form of the 30% nickel alloy is used containing, in addition to the major elements, 0.5% silicon, 1% manganese, and 1% iron. This is made primarily for cast fittings for use in conjunction with the wrought alloys in marine applications, salt-water lines, condensers, and similar uses. The cast alloy will develop a tensile strength of 63,000–66,000 psi, with a yield strength (0.2% offset) of 30,000–34,000 psi, and an elongation of 35–40% in 2 in.

#### SPECIAL CUPRONICKELS

Although the ordinary cupronickels are among the best of the copper-base alloys for resisting salt-water corrosion, several modifications of them are of some commercial importance. Many of these are proprietary alloys, developed to give either increased corrosion resistance or greater ease of fabrication than is shown by the usual cupronickel alloys. The alloys *Adnic*<sup>4</sup> and *Ambrac*,<sup>4</sup> in particular, are used in this country; and the *Kunial*

<sup>4</sup> Registered trade-marks.

alloys of copper, nickel, and aluminum have been used to some extent in England, although they have not enjoyed much success here. Any of them will fall within the limits of A.S.M.T. Standard B111 if they are used for condenser tubes or ferrule stock.

#### ADNIC

The addition of 1% tin to the standard 70:30 cupronickel alloy gives an alloy which has slightly better corrosion resistance and mechanical properties than straight cupronickel.<sup>5</sup>

The alloy is sold under the trade name Adnic, i.e., admiralty metal in which the zinc has been replaced by nickel. It has been used for condenser tubing, tableware, and diaphragms as well as several applications in the chemical industries. Since the tin is in solid solution, the microstructure of the alloy is similar to that of the cupronickels.

#### AMBRAC

The alloys sold under the trade name of Ambrac are essentially either 80:20 or 70:30 cupronickels in which 5% of the copper has been replaced by zinc. This produces no change in the metallographic structure and little change in the mechanical properties but makes the alloys very much easier to cast and work. The corrosion resistance is about the same as that of the cupronickels, but because of the greater ease of fabrication, the range of applications is somewhat wider. The uses for screen cloth, tableware, and tubes for heat exchangers, evaporators, and condensers are typical.

Cast alloys containing about 5% lead and 3% tin, in addition to the copper, nickel, and zinc, also are made. They have, in general, somewhat lower mechanical properties than the wrought alloys.

#### ALUMINUM BRONZE

The aluminum bronzes are copper-rich alloys, generally containing 5–10.5% aluminum, with the balance essentially copper, although not more than 4% iron, 9% nickel, and 10% manganese may be added also. Both wrought and cast forms of the alloy are made. The compositions of the three types most commonly used in this country are:

<sup>5</sup> Properties of this alloy are given in *Metals Handbook*, Ref. 2 at the end of this chapter.

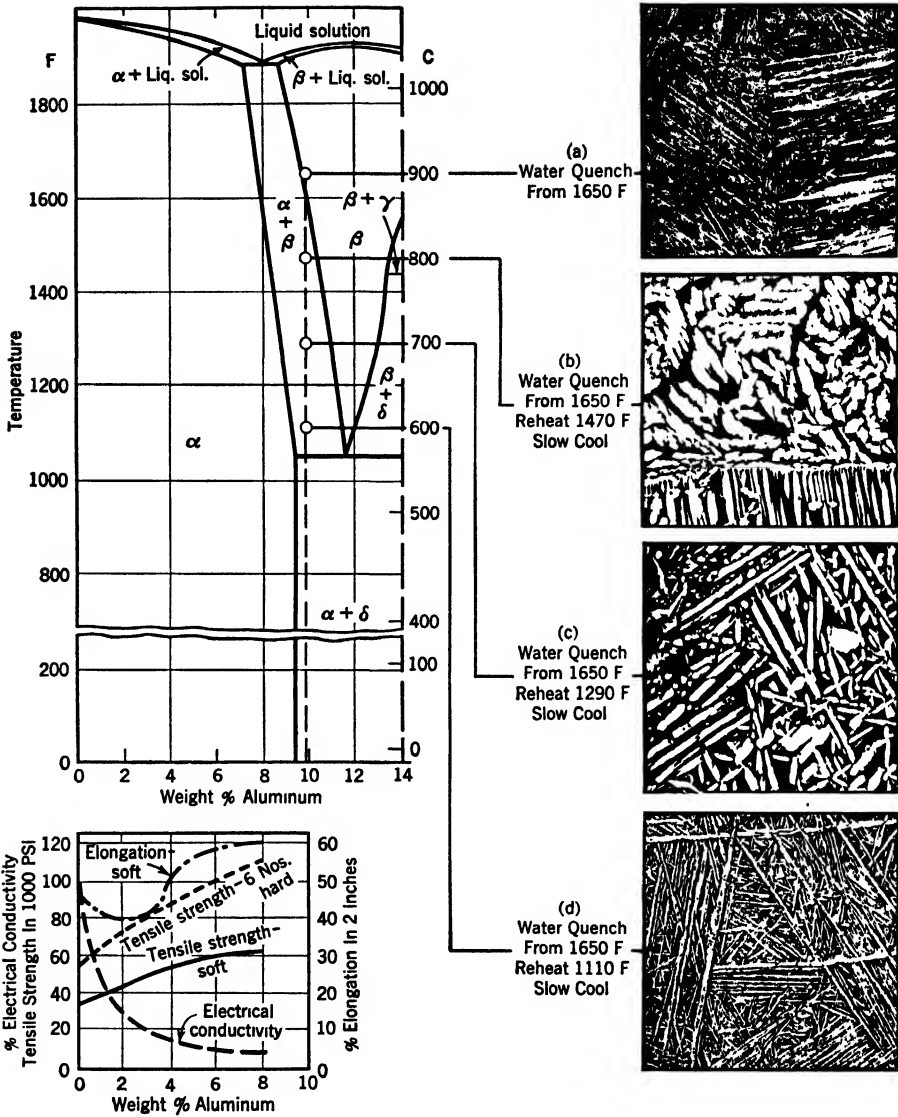


FIGURE 415. Changes in the metallographic structure of an aluminum bronze (90% Cu - 10% Al) as a result of heat-treatment.  $\times 100$  originally; reduced about one third in reproduction. The effect of composition on some properties of the solid solution alloys also is shown. (Courtesy Bridgeport Brass Co.)

- a. Water quenched from 1650 F (900 C). Etched with  $\text{NH}_4\text{OH} + \text{H}_2\text{O}_2$ . (Photomicrograph by S. J. MacMullan, Jr.) Martensiticlike structure is shown in portions of two grains. The grain size is very coarse because of the high heat-treating temperature.
- b. Reheat a to 1470 F (800 C) for 2 hr, cool slowly. Etched with Grard's No. 1. (Photomicrograph by C. T. Stott.) Coarse "needles" of  $\alpha$  in a finely dispersed eutectoid of  $\alpha$  and  $\delta$  are shown in portions of two grains.
- c. Reheat a to 1290 F (700 C) for 2 hr, cool slowly. Etched with  $\text{NH}_4\text{OH} + \text{H}_2\text{O}_2$ .

TYPE	% CU	% AL	% FE (MAX)	% OTHER ADDITIONS (NI, SI, SN, MN) (MAX)		% IMPURITIES (ZN, CD, PB) (MAX)
88:9:3	Rem.	8-11	1.5-3.5	4-7 Ni	0.5-2 Mn	0.50
95:5	92-96	4-7	0.50	—	—	0.50
92:8	90-93	7-9	0.50	—	—	0.50

These alloys are covered by S.A.E. Specification 701, A.S.T.M. Standard B171, and Tentative Standards B150-T, and B169-T, Federal Specification QQ-B-666, and Navy Specification 46-B-17b. The 95:5 and 92:8 types are used most commonly for plates, sheets, strips, and condenser tubes in this country, and the 88:9:3 type for other products in which less workability is required.

The 88:9:3 type in the forged or rolled condition will have a tensile strength of 70,000-95,000 psi with a yield point of 30,000-45,000 psi, and an elongation and reduction in area of 10-30%. In this condition it will have a Brinell hardness of 120-135. The 95:5 alloy will have a strength and elongation about 20% lower, with a correspondingly lower hardness; and the 92:8 alloy will be intermediate in properties. The aluminum bronzes may be worked readily both hot and cold, and some of them are subject to heat-treatment because of the nature of the constitutional diagram. The changes in microstructure produced by various heat-treatments are illustrated in Fig. 415 in relation to the copper-rich portion of the diagram.

With their good mechanical properties the alloys combine a resistance to the corrosive effects of the atmosphere, salt water, sulfuric acid, and other chemicals. In particular, they seem to resist the impingement type of attack particularly well because of the formation of a thin aluminum oxide film on the surface. This makes them valuable for condenser tubes under some conditions. Because of their hardness, and resistance to wear, shock, and fatigue, they have been used for diaphragms, gears, rods and bars requiring strength and resistance to corrosion, valve stems, and many other applications for which this combination of properties is particularly desirable. The alloys are apt to be somewhat difficult to machine because

(Photomicrograph by J. H. Dedrick.) The "needles" of  $\alpha$  are somewhat finer than in *b* because of the lower reheating temperature. Portion of a single grain is shown. *d.* Reheat *a* to 1110 F (600 C) for 2 hr, cool slowly. Etched with Grard's No. 1. (Photomicrograph by H. D. Nickol.) The "needles" of  $\alpha$  are noticeably finer than in *b* or *c* and the geometrical nature of their occurrence is very striking in the portion of a single grain shown. This is also a *Widmannstaetten* type of structure.



of the presence of small particles of aluminum oxide dross, but with properly ground tools of high-speed steel, machining can be done on a production basis. In addition free-machining types, containing about 0.5–1.0% tellurium are available commercially in some forms.

Cast aluminum bronzes of the 88:9:3, 86:10.5:3.5, and 88.5:10.5:1 types fall within the limits of both A.S.T.M. Tentative Standard B148-T and S.A.E. No. 68, but have somewhat lower mechanical properties than the wrought alloys as would be anticipated. The 88.5:10.5:1 alloy can be heat-treated in a manner similar to steel, i.e., quenched and drawn, to a minimum tensile strength of 80,000 psi with a minimum yield strength (0.5% elongation under load) of 50,000 psi and an elongation of 4% or better. The various *Ampco* alloys are probably the best known commercial types of aluminum bronze.

#### CAST RED BRASS

This commonly used alloy was at one time known as *composition brass* or *ounce metal* because the usual mixture was 1 oz each of tin, lead, and zinc to 1 lb copper. Today it is termed more usually *cast red brass*, or *eighty-five three fives* (85:5:5:5). The specifications usually adhered to are A.S.T.M. Standard B62 and its Tentative revision, B145-T, S.A.E. No. 40, and Federal QQ-B-691a, all of which call for 85% Cu–5% Sn–5% Pb–5% Zn,  $\pm 1\%$  of alloying elements in each case. More than 0.25% iron should not be present because it tends to give hard spots in the castings. Nickel usually is kept below 1% because it decreases the fluidity of the molten metal to some extent. Phosphorus is the usual deoxidizer and residual amounts of 0.05% are common. The alloy is fairly inexpensive, has good mechanical properties, casts readily, and is easily machinable because of its lead content. The specified mechanical properties call for a minimum tensile strength of 30,000 psi, with a minimum yield point of 14,000 psi, and an elongation in 2 in. of at least 20%. These properties can be met easily and, with care, can be exceeded materially.

The microstructure of this alloy is typical of that of a cored 7–8% tin bronze casting containing many small globular particles of lead, as illustrated in Fig. 416a.

Comparatively low-cost castings, which will be sound and free from internal porosity, can be made of this material. Hence it is used widely for many general utility purposes, where reasonable strength and corrosion resistance are required, as well as for pressure castings. It is also satisfactory for bearings, and for general engineering applications at temperatures not exceeding 450 F (230 C). The mechanical properties are retained well

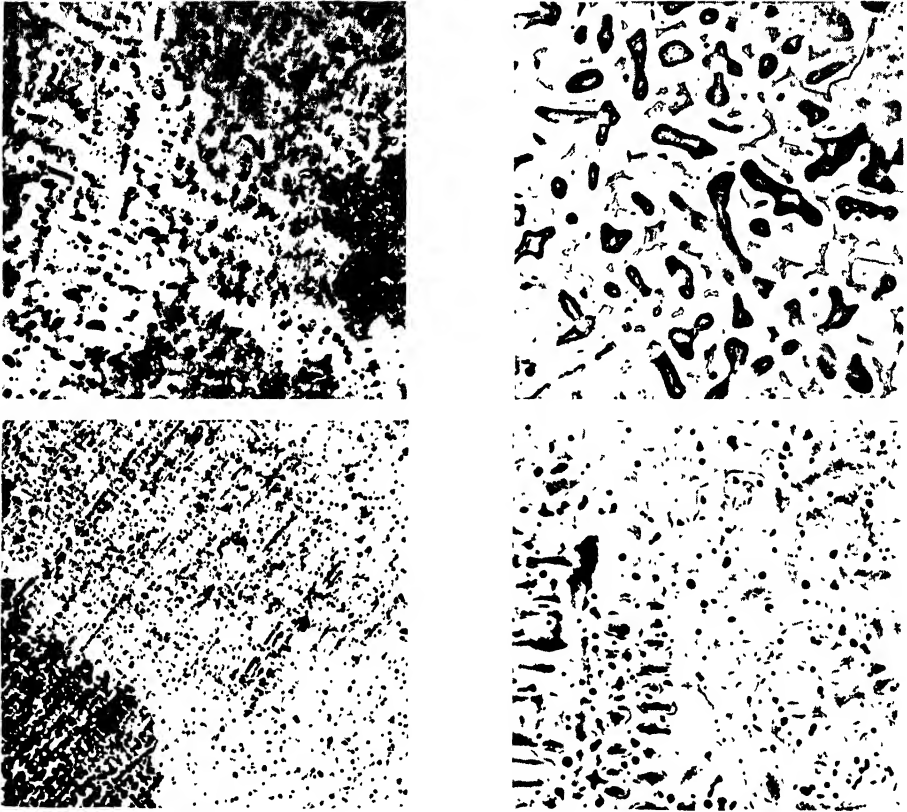


FIGURE 416. Metallographic structures of some cast brasses and bronzes. (Photomicrographs courtesy Crane Co. Research Laboratories.)

a. (Upper left) Ounce metal (cast red brass) (85% Cu - 5% Sn - 5% Zn - 5% Pb). Etched with  $\text{NH}_4\text{OH} + \text{H}_2\text{O}_2$ .  $\times 50$ .

b. (Upper right) Composition G (88% Cu - 10% Sn - 2% Zn). Etched with  $\text{NH}_4\text{OH} + \text{H}_2\text{O}_2$  to develop cored dendrites, lightly polished and reetched in  $\text{FeCl}_3$  to increase contrast.  $\times 100$ .

c. Composition M (89% Cu - 6% Sn - 3% Zn - 2% Pb). Etched with  $\text{NH}_4\text{OH} + \text{H}_2\text{O}_2$ .  $\times 25$  (lower left);  $\times 75$  (lower right).

up to about 400 F (200 C), but the alloy should not be used above 450 F because of a tendency toward embrittlement.

Modifications of the 85:5:5:5 composition, which have been used for a wide variety of brass castings in which it is desired to secure a red color at a low cost, are the alloys containing, nominally, (a) 83% Cu-4% Sn-6% Pb-7% Zn, known as *commercial red brass*, (b) 81% Cu-3% Sn-7% Pb-9% Zn, commonly known as *medium red brass* or *valve composition*, and (c) *semired brass*, 76% Cu-3% Sn-6% Pb-15% Zn. Radiator valves, low-pressure steam and water fittings, and other valves operating at pressures of not more than 50 psi and maximum temperatures of 250 F (120 C) and for

which good casting and machining characteristics are required are typical of the common uses of these alloys.

Mechanical properties will not be greatly inferior to those for 85:5:5:5, so these modified compositions will generally be included within the same specifications that cover the other red-brass alloy.

#### YELLOW BRASS

Still lower cost alloys which, however, have neither the mechanical properties nor the color of the red brasses, are the yellow-brass casting alloys covered by A.S.T.M. Standard B146 and Federal Specification QQ-B-621. These are of three types containing, respectively, 71% Cu-1% Sn-3% Pb-25% Zn, 66% Cu-1% Sn-3% Pb-30% Zn, and 60% Cu-1% Sn-3% Pb-36% Zn. Because of the relatively high allowable impurity limits these compositions usually can be made entirely of miscellaneous yellow-brass scrap and hence are somewhat cheaper than the red alloys. Although they do not cast so well and are not suitable for pressures or temperatures comparable to the red brasses they find considerable use for miscellaneous yellow-brass castings, especially in the general plumbing field. For this reason the name of *plumber's brass* sometimes is given to them.

The metallographic structure of these alloys would be comparable to that of cast red brass shown in Fig. 461a. Particles of insoluble lead are seen in a matrix of a cored  $\alpha$  solid solution of tin and zinc in copper.

#### 88:10:2 BRONZE

Alloys of this composition are known as *government bronze*, *composition "G," gunmetal*, *admiralty gunmetal*, and *zinc bronze*. Generally, the composition corresponds to the range 87-89% copper, 9.5-10.5% tin, 1.5-2.5% zinc, with maximum amounts of several other alloying elements specified. A modification known as 88:8:4, containing 7.5-8.5% tin and 3.5-4.5% zinc, has been used, especially for castings of large cross section, but with a very slow rate of cooling it tends to have a structure that is difficult to machine. The machinability of the alloy may be increased by the addition of 0.5-1.5% lead and, sometimes, by the addition of 0.75% nickel as a stiffener. The leaded varieties are known as *commercial "G"* or *composition "M"* depending upon the allowable impurities and the mechanical properties required.

These cast bronzes are covered by A.S.T.M. Tentative Standard B143-T, S.A.E. No. 62, Federal Specification QQ-B-691a, and U. S. Navy Specifications 46-M-6g, 46-B-5h, and 46-B-8g. A minimum tensile strength of

40,000 psi generally is required, but the mechanical properties in general are much better than those of cast red brass, largely because of the lower lead content. The alloys are important because they combine the properties of strength and toughness with bearing qualities, good casting characteristics, and resistance to sea-water corrosion. Typical microstructures, showing the presence of the  $\delta$  copper-tin constituent which always tends to form to some extent when the zinc content is low and the rate of cooling moderate, are illustrated in Fig. 416*b* and *c*.

The alloys are excellent steam and structural bronzes which may be used for expansion joints, pipe fittings, gears, bolts, nuts, valves, pump pistons, castings, bushings, bearings, and other uses in naval marine work. Best results are secured with castings that have been annealed at 1400 F (760 C) for 1 hr per inch of thickness and air cooled prior to machining. This heat-treatment makes the casting more pressure-tight and gives it better ductility.

The manganese bronzes, which are discussed in Chap. XVI because of their higher strengths, also are used for many applications in this field.

#### ALUMINUM ALLOYS

Several aluminum-base casting alloys which possess an excellent combination of mechanical properties and corrosion resistance have been developed. The alloying elements in four of these, with the alloy designation used by the Aluminum Company of America, are:

ALCOA NO.	A.S.T.M. B26-T*	S.A.E.	% MG	% SI
220	G3	324	10	—
214	G1	320	3.8	—
43	S1	35	—	5
356	SG1	323	0.3	7

\* This covers sand castings; the designations in B108-T (Permanent Mold Castings), and B179-T (Ingots) are similar.

The alloys containing magnesium, 220 and 214, are used chiefly for sand castings although permanent mold castings are made from the latter alloy by adding about 1.8% zinc (alloy A214), and die castings are made containing 8% magnesium (alloy 218). Alloy 220 can be heat-treated to give

an average tensile strength of 45,000 psi, with a yield strength (0.2% offset) of 25,000 psi, and an elongation of 14% in 2 in. Tensile strengths of 214 alloy, which is not heat-treatable, will be lower, averaging 25,000 psi, with yield strengths (0.2% offset) of 12,000 psi, and elongations of 9%. Brinell hardnesses (10 mm–500 kg) of 75 for alloy 220 and 50 for alloy 214 are typical. Alloy 220, in the -T4 temper, combines the highest strength, elongation, and impact resistance of any of the aluminum-alloy castings with excellent machining characteristics and resistance to corrosion. These alloys are used for castings in dairy, chemical, and sewage disposal plants, cooking utensils, pipe fittings, marine castings, and certain small ornamental castings where a white, highly polished finish and stain resistance are required. Neither of the alloys containing magnesium, however, are suitable for castings which are required to be pressure-tight or are intended for use at elevated temperatures.

The metallographic structure of 214 in the sand cast condition is shown in Fig. 417. Particles of  $\alpha$  (Al-Mg) secondary solid solution have precipitated from a matrix of aluminum-rich primary solid solution. Because of its high strength, 220 is discussed further in Chap. XVI and its structure is shown in Fig. 476.

Aluminum-silicon alloys are used for sand, permanent mold, or die castings because of their good fluidity and low shrinkage on solidification. The silicon may vary for specific purposes from 3–12% although the usual limits for any specific composition are +1%, –0.5%. Depending upon the type of casting made, average tensile strengths of 19,000–29,000 psi, with yield strengths (0.2% offset) of 9,000–13,000 psi, and elongations of 3.5–6% can be secured. Brinell hardnesses (10 mm–500 kg) will be 35–55. The sand-cast alloys have lower mechanical properties than permanent-mold or die-cast alloys although even the die castings have properties somewhat inferior to those of the older aluminum-copper alloys. The aluminum-silicon alloys are, however, more ductile and resistant to shock than the aluminum-copper alloys.

The machining of alloys of this type is apt to be difficult because of the free silicon and its effect on the tools. The properties of the 5% silicon alloy make it very satisfactory for marine castings, manifolds, water jackets, and many other intricate shapes, especially architectural and ornamental shapes having thin sections and not requiring much machining. The alloy given in S.A.E. 304 (die castings) and alloy S2 covered by A.S.T.M. Tentative Standards B26-T, B108-T and B179-T (Ingots) are similar to this composition. The die-casting alloy is covered by A.S.T.M. Tentative Standard B85-T (Alloy S4). The structure shown in Fig. 418 is typical although the silicon frequently is considerably finer.

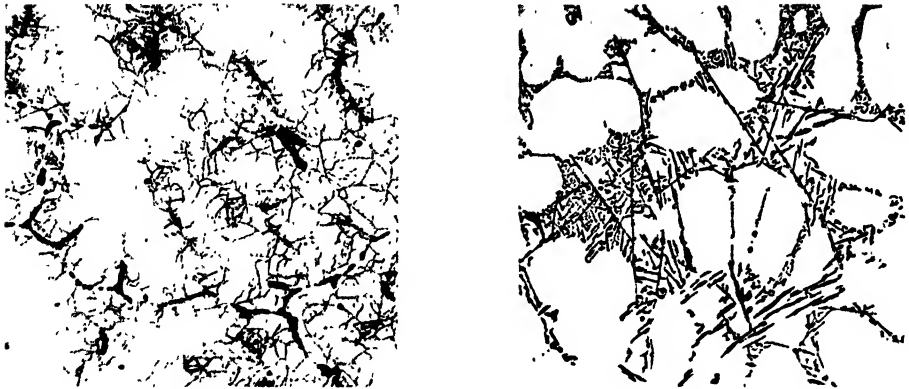


FIGURE 417. (Left) Metallographic structure of aluminum alloy 214 (3.8% Mg — rem. Al) as sand cast. Etched with Keller's reagent.  $\times 100$  (Photomicrograph courtesy Aluminum Research Laboratories.) The structure of alloy 220 (10% Mg — rem. Al) in the sand-cast and aged condition is shown in Fig. 476.

FIGURE 418. (Right) Metallographic structure of aluminum alloy 43 (5% Si — rem. Al) as sand cast. Etched with  $\frac{1}{2}\%$  HF.  $\times 100$ . (Photomicrograph courtesy Aluminum Research Laboratories.)

Alloy 356 is also susceptible to heat-treatment and possesses, in addition to the higher strengths produced in this manner, excellent casting characteristics and corrosion resistance. Its principal use is for castings requiring this combination of properties. Permanent-mold castings will give better properties than sand castings for the same composition because of the more rapid solidification. Several different heat-treatments have been developed to give particular combinations of properties for specific purposes. Depending upon which of these is used, average tensile strengths from 28,000–40,000 psi, with yield strengths (0.2% offset) of 16,000–24,000 psi, and elongations of 2–9% may be produced. The Brinell hardness (10 mm–500 kg) after these treatments may range from 55–90. Because of its good mechanical properties this alloy also is discussed in Chap. XVI. Its metallographic structure, in the heat-treated condition, is given in Fig. 478.

#### *For Further Study Refer to*

1. *Corrosion Resistance of Metals and Alloys*, by R. J. McKay and R. Worthington: Reinhold Publishing Corporation, New York, 1936.
2. *Metals Handbook*: American Society for Metals, Cleveland, Ohio, 1939 (usually published triennially). A new edition will appear in 1948.
3. *Wrought Iron*, by J. Aston and E. B. Story: A. M. Byers Co., Pittsburgh, Pa., 1939.
4. *Copper Steels to Resist Corrosion*: Copper Development Assoc., London.

5. *Copper in Cast Steel and Iron*: Copper Development Assoc., London.
6. *The Use of Copper for Domestic Water Services*: Copper Development Assoc., London.
7. *Copper Pipe-Line Services in Building*: Copper Development Assoc., London.
8. *Aluminum Bronze*: Copper Development Assoc., London.
9. Publications of:
  - Aluminum Company of America, Pittsburgh, Pa.
  - American Brass Co., Waterbury, Conn.
  - Bridgeport Brass Co., Bridgeport, Conn.
  - Chase Brass & Copper Co., Waterbury, Conn.
  - International Nickel Co., Inc., New York, N. Y.
  - Permanente Metals Corp., Oakland, Cal.
  - Revere Copper and Brass Co., New York, N. Y.
  - Reynolds Metals Co., Louisville, Ky.
  - Scovill Mfg. Co., Waterbury, Conn.
  - U. S. Steel Corporation, New York, N. Y.

## Alloys Resistant to Chemical Corrosion and the Action of Heat

**M**OST OF THE IRON- OR NICKEL-BASE ALLOYS WHICH HAVE sufficient corrosion resistance to withstand the more severe types of chemical attack also will have fairly good heat-resisting characteristics. Both groups of alloys, therefore, will be discussed together. However, except for certain lead alloys, which are used widely because of their resistance to neutral and some acid solutions, and a few aluminum alloys, such as those used for cylinder heads and pistons in internal combustion engines, few if any of the other nonferrous metals or alloys would fall in this classification.

### CREEP

For engineering applications involving elevated temperature service the creep characteristics of the material are frequently of major importance. This importance has increased directly with the increase in operating temperatures and pressures in both mechanical and chemical equipment.<sup>1</sup> In turbine blades, flange belts, autoclaves, pressure stills, high-pressure boilers, steam lines, and similar applications failure can result readily from creep unless the proper factors are considered in the original design, and the proper alloys are used.

The creep data available have been collected largely in the laboratory.<sup>2</sup> Before about 1925, little was known regarding the strength of metals at elevated temperatures. Ordinary tensile strengths have little significance in this range because actual operating results depend on the effects of moderate loads applied for long periods of time rather than those of higher

<sup>1</sup> See, for example, H. W. Gillett, *Trans. A.I.M.E.*, **135**, 1939, 15-58.

<sup>2</sup> See J. A. Fellows, E. Cook, and H. S. Avery, *Trans. A.I.M.E.*, **150**, 1942, 358-372; also Refs. 8 and 9 at the end of this chapter.



loads applied rapidly as in the usual short-time tensile test. At temperatures above 1000 F (540 C), in particular, the discrepancy between short-time and long-time tests is very marked.

Creep tests conducted before about 1935 were apt to be unreliable because of uncontrolled variations in specimen size, test temperature, or length of test; but, since that time, most tests have been made on standard specimens and conducted under conditions recommended by the Joint High Temperature Committee of A.S.M.E. and A.S.T.M. For further information refer to A.S.T.M. Standard E22.

Data secured in this manner are much more reliable than those of earlier date and results from different laboratories correlate well. However, creep data still must be used with proper regard for the conditions under which they were secured. In particular, extrapolation is not recommended.

Generally, creep data are expressed as a stress producing 1% elongation by creep in 1000, 10,000, or 100,000 hr, depending largely on the magnitude of the elongation and the accuracy, reproducibility, and uniformity of the test results.

The creep resistance of a material appears to be a very sensitive property and is influenced by many factors, some of which are very difficult to control commercially. Of these, the following may be mentioned in particular:

1. Composition
2. Method of manufacture, including melting practice and method of deoxidation
3. Heat-treatment and initial microstructure
4. Surface stability
5. Grain size and general microstructural stability

Of necessity, most of the discussion involving these factors will deal with steels since these are the materials most commonly used for this purpose.

**COMPOSITION** Below 1000–1100 F (540–590 C) low- or mild-alloy steels may be quite adequate for most applications. Above this range, however, the higher alloyed stainless steels must be used. Unfortunately, the best composition to use cannot be determined entirely empirically because combinations of alloying elements do not always produce the same resistance to creep that each would alone.

In steels that are initially pearlitic or spheroidized, molybdenum and tungsten are very potent and, to a lesser degree, chromium, vanadium, and manganese tend to increase creep resistance.<sup>3</sup> Among the more highly alloyed steels, the austenitic stainless steels and certain special alloys are

<sup>3</sup> See, for example, C. L. Clark and A. E. White, *Trans. A.S.M.*, **24**, 1936, 831–878.

superior at the higher temperatures.<sup>4</sup> Small additions of silicon and aluminum also exert beneficial effects on the creep resistance of steels by increasing oxidation resistance.

**METHOD OF MANUFACTURE** The effects of steel melting practice may be so marked as to vary the creep rate several hundred per cent.<sup>5</sup> For example, at 850 F (450 C) straight silicon-killed steels, free from aluminum treatment and with a coarse grain structure, are much more resistant to creep than rimmed, or similar undeoxidized steels, or than killed steels treated with large amounts of aluminum and with a fine grain size.

Similar results have been secured, at 1000 F (540 C) on the low-carbon, 0.5% molybdenum alloy which has been used so widely, in the past, for high-pressure steam lines.

It may be significant that these low-carbon low-alloy steels generally are melted in the open hearth, a process in which wide variations in deoxidation practice commonly are encountered. On the other hand, both the mild and the more highly alloyed steels usually are melted in the electric furnace under the more rigid conditions followed in alloy steel practice and, even if melted in the open hearth, they would be subject to more closely controlled conditions than would be the case with the unalloyed low-carbon steels.

**HEAT-TREATMENT** The initial heat-treatment and structure also have a much more pronounced effect on the creep resistance of the plain carbon and low-alloy steels than on that of the mild and more highly alloyed steels. This again is largely attributable to the fact that many more variations in heat-treatment are likely to be used with the former than with the latter alloys. The characteristics of the mild and more highly alloyed steels are usually such that only a definite heat-treatment may be used to develop the fabricating properties required and hence marked variations in grain size and heat-treatment seldom are encountered. However, when they are encountered, as in the ferritic alloy steels containing 1–9% chromium with varying additions of molybdenum, they are equally as important as in the plain carbon steels.

The real importance of initial heat-treatment probably is determined more by the stability with time at test or service temperature than by any other factor. This will be discussed in more detail below, but it should be clear by now that the initial structure will tend to change with time to any

<sup>4</sup> See C. R. Austin and H. D. Nickol, *Journ. Iron & Steel Inst.*, London, **137**, 1938, 177–217; also C. T. Evans, Jr., *Metal Progress*, **48**, 1945, 1083, particularly for design information.

<sup>5</sup> For low-carbon steel, of the type used for boiler plate and Grade "A" pipe, this has been very well reviewed in the 1940 Report of the Joint High Temperature Committee: *Proc. A.S.T.M.*, **40**, 1940, 140. For the mild alloy steels, much less is known at this time.

structure which is more stable. Thus a pearlitic structure will tend to change to a spheroidal structure, and a fine spheroidal structure to a coarse spheroidal or possibly a graphitic structure. The rate of this transformation depends, of course, on the test or service temperature. Initial heat-treatment or initial structure, therefore, can only influence the *long-time* creep rate if it produces or is a structure which is essentially stable and does not change throughout the "life" of the part regardless of whether this is determined by a creep test or by actual service. Each particular application must be considered individually with these points in mind.

**SURFACE STABILITY** Parts subject to creep are designed for a definite load per unit cross section. If, in service, oxidation or other corrosion causes the *effective cross section* to decrease, then the unit load will increase and the creep rate will become that resulting from the new unit load.

This factor is so important that pipe handling high-pressure steam in modern installations usually is subjected only to the action of very pure steam. Only traces of carbon monoxide, water vapor, or oxygen can be allowed to remain because of the action of these impurities on hot irons.<sup>6</sup> This action is particularly important at temperatures above 1000 F (540 C).

Alloys for high-temperature service sometimes are given protective coatings of oxidation resistant materials, such as aluminum (calorizing), in order to decrease surface oxidation. Likewise alloying additions of varying amounts of silicon, aluminum, nickel, or chromium tend to increase surface stability by forming very thin films of stable oxides on the surface, thus protecting it against progressive oxidation and scaling.

**MICROSTRUCTURE** Toward the lower limits of the temperature range of usefulness of any particular alloy, grain size does not appear to be especially significant and any slight superiority seems to favor the finer grain structures. However, toward the upper limits, the coarse grain structures are definitely superior.<sup>7</sup> Whether this results from an actual effect of grain size (or of relative amount of grain boundary material) or is merely a manifestation of the greater structural stability of the larger grain size has not been established definitely as yet.

The factor which is most significant as far as microstructure is concerned is the effect of time at the service or test temperature. Lamellar pearlite, which is a common constituent of plain carbon and low-alloy steels, will spheroidize fairly rapidly at temperatures above 850 F (450 C).

<sup>6</sup>This subject has been covered thoroughly by work done in the Research Laboratory of The Detroit Edison Company, see I. A. Rohrig, R. M. Van Duzer, Jr., and C. H. Fellows: *Trans. A.S.M.E.*, May 1944, 227; and at Purdue University under the auspices of the A.S.M.E. Boiler Code, see H. L. Solberg, G. A. Hawkins, and A. A. Potter, *Trans. A.S.M.E.*, 64, May 1942, 303.

<sup>7</sup>See for example, C. L. Clark and A. E. White, *Proc. A.S.T.M.*, 32, 1932, 492-516; *Trans. A.S.M.*, 22, 1934, 1069-1098.

A pearlitic initial structure, consequently, is a poor one to use in these temperature ranges unless this fact is understood thoroughly by the designer and proper compensation is made for it. If the exposure to the elevated temperatures is continued long enough the cementite spheroids may even graphitize. The alloy then will become, essentially, a mixture of ferrite, either plain or alloyed, and graphite nodules with a structure similar to that of a malleable iron but with a lower carbon content (cf. Fig. 402*b*). Both the tensile strengths at room temperature and the creep strengths at elevated temperatures are much lower for the spheroidized and graphitized structures than for the original pearlitic structure.

In 1942, a main steam line in a large central station failed because of graphitization in this manner. The pipe, made of low-carbon 0.5% molybdenum steel, had been in service over 5 yr at temperatures between 925 and 1010 F (495–545 C). Graphitization had occurred a short distance away from the welds as well as in a few scattered places throughout the rest of the pipe. This particular pipe was made from fine-grained steel deoxidized with considerable amounts of silicon and aluminum and then normalized after rolling to reduce the grain size further. However, in spite of this serious failure, thousands of feet of pipe made of similar material have given continuous service for up to 15 yr at temperatures in the range 850–950 F (450–510 C) even though some graphitization has occurred in it. The coarse-grained type of the same alloy, which has been in general use since 1938, is considerably more resistant to graphitization than the fine-grained material. However, as far as is now known, iron carbide is always less stable than graphite in these temperature ranges and will tend, in time, to transform to graphite (and ferrite) if the proper conditions obtain. The only uncertainty is the rate at which the transformation will occur.

Transformations, but of a different type, also occur in the more highly alloyed chromium-nickel austenitic steels during long-time use at elevated temperatures even though the carbon content generally is limited to 0.08% or 0.12% in forgings and 0.20% in castings. Initially these steels usually are quenched from about 1900 F (1040 C) thus retaining all the carbides in solution. During long-time exposure to temperatures in the range 900–1300 F (480–700 C), however, the carbides tend to precipitate at the grain boundaries thus greatly decreasing the ductility of the material as well as its resistance to corrosion and oxidation. As will be discussed later, this difficulty can be minimized by proper alloy selection.

The effects of stress on these structural changes seem to be uncertain. Under some conditions stress apparently will accelerate the transformations, but under others it appears to have little or no effect.<sup>8</sup>

<sup>8</sup>See, for example, C.R. Austin and H. D. Nickol, *loc. cit.*; and H. W. Gillett, *loc. cit.*

## UTILIZATION OF CREEP DATA

It must be remembered always by engineers that creep data are secured, as a rule, under simple tensile loading. A torsional creep test has been developed,<sup>9</sup> but it is not used widely, and other more complex loadings are being studied but the tests are still in their early stages. In engineering applications, on the other hand, metals seldom are subjected to simple loading, so strictly comparable conditions do not obtain.

Worth-while tests are very time consuming—there are only 8760 hr in a calendar year and a test should be conducted for times of the order of 10,000 hr to be considered reliable—and frequently it is found that short-time, viz., 500–1000-hr tests, do not give results that are comparable to long-time tests. No truly successful method has been found for speeding up the process of creep testing. Unfortunately, creep data frequently are desired by the engineer in a much shorter time than they can be secured safely. There is no method yet known for predicting results or data accurately, although rough approximations can be secured in some cases. Mathematical analysis has been attempted for both simple and compound stress systems, but with only fair success.

Because of all these factors, the creep data available must be used with extreme caution and, preferably, only on the basis of experience. The A.S.M.E.-A.S.T.M. Joint Research Committee and various other committees of these two societies have issued codes covering the allowable working stresses for both ferrous and nonferrous materials under the usual working conditions; and, for safety, their recommendation should be followed wherever possible. If this cannot be done, then sizable factors of safety must be used.

## LOW-CARBON AND INTERMEDIATE-ALLOY STEELS

One of the milder forms of corrosion to which alloys in the classification covered in this chapter are subjected is that encountered in certain oil-refinery stills where seamless tubes are required to carry oil at elevated temperatures and pressures either through furnaces which are somewhat hotter than the oil or else through heat exchangers or condensers.<sup>10</sup> In many instances the requirements for this type of service can be filled satisfactorily by an ordinary silicon-killed low-carbon open-hearth or electric steel of one of the types covered by A.S.T.M. Standards A161 and A179 as well as by several Tentative Standards, and conforming to the analysis limits:

<sup>9</sup>M. C. Fetzer, *Trans. A.S.M.*, 26, 1938, 850–884.

<sup>10</sup>For a complete discussion see J. A. Jamison, *Proc. Amer. Pet. Inst., Sec. III*, 1938, 46–56.

	% C	% MN	% P (MAX)	% S (MAX)	% SI (MAX)
	0.10–0.20	0.30–0.60	0.04	0.045	0.25

This type of alloy will have a minimum room temperature tensile strength of 47,000 psi, 26,000 psi yield point, and 35% elongation in 2 in., with a maximum hardness of 137 Brinell if hot-rolled, or 125 Brinell or Rockwell B65 if cold-drawn and annealed. The microstructures of these tubes will show frequently considerable pearlite banding (cf. Fig. 461*b*) although this is not considered to be particularly desirable.

In many applications either the operating conditions, i.e., temperature and pressure, or the corrosive conditions will be too severe for the plain carbon steel tubes. If the principal difficulty lies in the operating conditions, a shift to low-alloy steel tubes, containing about the same carbon, manganese, sulfur, and phosphorus as the low-carbon tubes and, in addition, either 0.5% molybdenum or a combination of 0.45–1.0% molybdenum with 1.0–3.25% chromium and up to 1.0% silicon frequently will give a satisfactory service life. Six grades of these steels are covered by A.S.T.M. Standards A199 and A200, and several Tentative Standards also include them. The carbon-molybdenum alloy tubes are covered by A209. These alloys will have room-temperature strengths appreciably higher than those of the plain carbon steels with a minimum tensile strength of 60,000 psi, 25,000 psi yield, 30% elongation in 2 in. and a maximum hardness of 163 Brinell or Rockwell B85. In addition they will retain their strength much better at elevated temperatures and have better creep properties than the low-carbon steels.

If, however, both the corrosive conditions and the operating conditions are too severe for the low-alloy steels, then intermediate-alloy steels of the 4–6 chromium or the high-alloy 18:8 stainless types must be used. Both of these are more expensive than the low-alloy steels so the economics of each application must be considered on its own merits.

#### 4-6 CHROMIUM STEEL

The intermediate-alloy steels containing, nominally, 5% chromium, 0.5% (max) each of silicon and manganese, and 0.10–0.35% carbon, with the remainder iron, have been used widely for cracking-still tubes and many

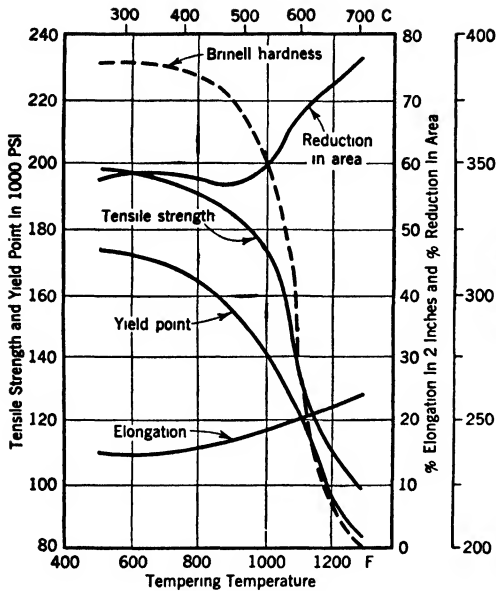


FIGURE 419. (Left) Effect of tempering temperature on the tensile properties of a 1-in. round of 4-6% chromium steel, containing 0.19% carbon and 0.5% molybdenum, after oil quenching from 1700 F (930 C). (Courtesy The Carpenter Steel Company.)

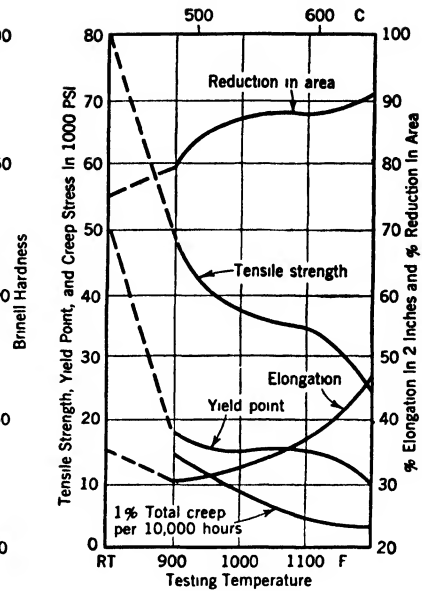


FIGURE 420. (Right) Tensile properties at elevated temperatures of an annealed 4-6% chromium steel containing 0.19% carbon and 0.5% molybdenum. (Courtesy The Carpenter Steel Company.)

other oil-refinery applications under moderately severe conditions.<sup>11</sup> Several grades are made depending on the carbon content, and either 0.5% molybdenum or 1% tungsten usually is added to increase the high-temperature strength.

All of these alloys are very ductile and soft even in the rolled condition and are worked readily, both hot and cold, and machined. As a group, the moderately priced 4-6 chromium steels will give more than five times the life of plain carbon steel tubes in some applications, and resist both sulfide corrosion and high-temperature oxidation much better.

In Fig. 419 are plotted typical properties for a 1-in. bar of 4-6 chromium steel, containing 0.19% carbon and 0.5% molybdenum, after oil quenching from 1700 F (930 C) and tempering at the temperatures shown. After these treatments, the alloy will have a fine sorbitic structure. The data plotted in Fig. 420 indicate the manner in which the tensile properties are retained at elevated temperatures, both in short-time tensile and in creep tests.

These intermediate-alloy steels have greater resistance to scale and oxi-

<sup>11</sup> See, for example, W. G. Hildorf, C. L. Clark and A. E. White, *Trans. A.S.M.*, 27, 1939, 1090-1114; and E. S. Dixon in Chap. 18A of Ref. 1 at the end of this chapter.

ation than ordinary carbon steel, and can be used continuously up to about 1000 F (540 C) with satisfactory results. However, at atmospheric temperatures, their corrosion resistance is approximately proportional to their chromium content.

Because of their chromium content, welds made with these alloy steels will air-harden when cooled from any temperature above 1500 F (820 C). Hence all fabricating operations on these materials should be followed by heating the entire piece to a temperature of at least 1500 F (820 C) and then cooling at a rate not exceeding 50° F (25° C) per hour until a temperature of 500 F (260 C) is reached; below this temperature the cooling rate does not seem to be important. The addition of titanium in amounts equal to at least five times the carbon content or columbium in amounts equal to ten times the carbon content will make the alloy nonhardenable by forming an insoluble titanium or columbium carbide at temperatures below 1800 F (980 C), thereby removing the cause of the austenite-martensite transformation and allowing the chromium, which would otherwise form chromium carbides, to remain in solid solution in the iron and increase its corrosion resistance somewhat.

Typical microstructures of a weld section in both the hardened and the fully softened condition are shown in Fig. 421. These structures are also typical of hardened and annealed 4-6 chromium steels in general.

Castings of 4-6 chromium steel, which also are used widely in oil-refinery construction, generally contain either about 0.5% molybdenum or 1% tungsten in addition to the standard base analysis previously given, and will have properties approximating:

Tensile strength, psi	110,000-120,000
Yield point, psi	75,000- 85,000
Elongation, % in 2 in.	16- 20
Reduction in area, %	30- 55
Brinell hardness (10 mm-3000 kg)	210-250

These castings usually are given a heat-treatment consisting of the three steps:

1. Normalizing from above 1750 F (950 C)
2. Reheating to 1650-1700 F (900-930 C) and soaking, followed by cooling in still air
3. Drawing at about 1250 F (680 C)

This treatment will give a very fine sorbitic structure, having good ductility and practical freedom from internal stresses.

Alloys of the 4-6 chromium group are covered by American Iron and



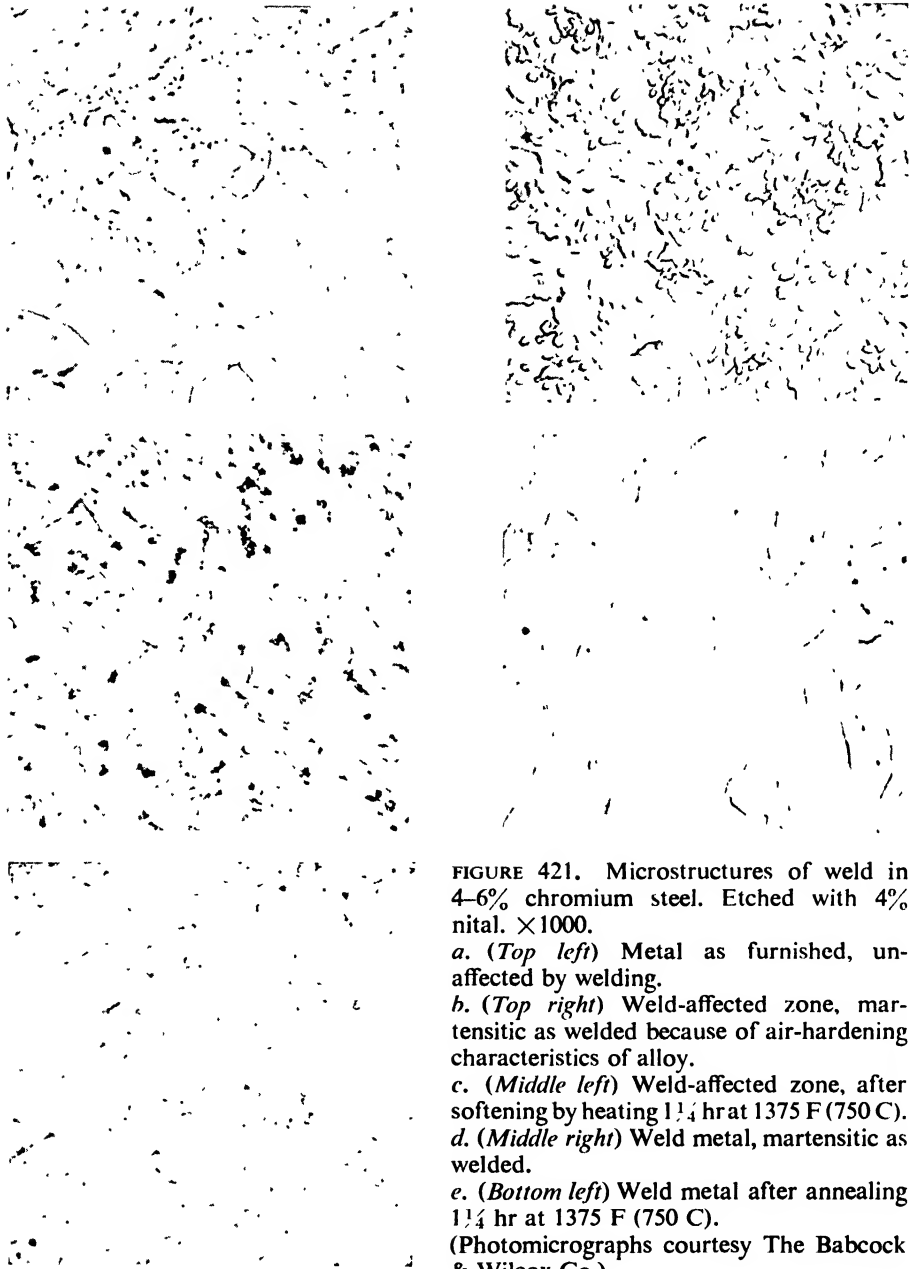


FIGURE 421. Microstructures of weld in 4-6% chromium steel. Etched with 4% nital.  $\times 1000$ .

*a.* (Top left) Metal as furnished, unaffected by welding.

*b.* (Top right) Weld-affected zone, martensitic as welded because of air-hardening characteristics of alloy.

*c.* (Middle left) Weld-affected zone, after softening by heating  $1\frac{1}{4}$  hr at 1375 F (750 C).

*d.* (Middle right) Weld metal, martensitic as welded.

*e.* (Bottom left) Weld metal after annealing  $1\frac{1}{4}$  hr at 1375 F (750 C).

(Photomicrographs courtesy The Babcock & Wilcox Co.)

Steel Institute (A.I.S.I.) Types 501 and 502; and by A.S.T.M. Standard A213 (Boiler and Super Heater Tubes), and Tentative Standards A158-T

(Pipe for Service at 750–1100 F), and A193-T (Bolting for Service at 750–1100 F).

Some of the common trade names under which they are sold are *U.S.S. 4-6* and *5*, *Allegheny 46*, *Uniloy 4-6*, *V-Chrome, #104*, *Bethadur 501* and *502*, *B. & W. 400*, *401*, and *402*, *LoCro 46*, *Enduro 4-6 Cr*, *Sicromo*, *Alcrosil*, and *Otisel K-4* and *K-5*. Sometimes the word “molybdenum” (Mo) or “tungsten” (W) is added to indicate the presence of these elements.

#### CLASSIFICATION OF THE STAINLESS STEELS

The so-called stainless steels are by no means stainless, and most of them should be classed strictly as iron-base alloys rather than as steels because of their low carbon content. However, they are resistant to a wide variety of corroding conditions. With this resistance they combine such good mechanical and physical properties that only their comparatively high cost keeps them from finding a much wider use than they actually enjoy at the present time.<sup>12</sup>

The various alloys of this group may be considered most simply under three classifications, depending upon their microstructure:

1. *The Hardenable Alloys*. These are martensitic when quenched and pearlitic when annealed. They can be identified by the simple rule that the chromium content minus seventeen times the carbon content equals less than 12.5%. The hardenable alloys are magnetic, and usually contain less than about 16% chromium with less than about 0.4% carbon. They may contain also small amounts of tungsten, copper, nickel, silicon, or molybdenum.
2. *The Ferritic Alloys*. These have a normal annealed structure of ferrite and carbides but do not harden by heat-treatment. In this class the chromium content minus seventeen times the carbon content equals more than 12.5%. The ferritic alloys are also magnetic, and usually contain more than about 16% chromium with a low carbon content except in the higher chromium alloys. Small amounts of tungsten, copper, nickel, silicon, or molybdenum also may be added.
3. *The Austenitic Alloys*. These contain enough chromium and nickel to depress the critical well below room temperature and thus make them both austenitic and nonmagnetic. Usually the carbon is very low and the combined chromium and nickel content is greater than 24% with not less than 7% of either element.

<sup>12</sup> Ref. 1, at the end of this chapter, discusses many of these uses in detail.

## THE HARDENABLE ALLOYS

The hardenable stainless steels containing 11.5–14% chromium are sometimes called *stainless irons* if they contain less than 0.15% carbon (A.I.S.I. Types 403, 405, 406, 410, 414, 416, 418, or S.A.E. No. 51210). Likewise the name *cutlery type* is used to designate the alloys containing 11–14% chromium and 0.30% carbon, (A.I.S.I. Type 420 or S.A.E. No. 51335). These are the two commonest subclassifications. Wrought metal for many applications of both types is covered by A.S.T.M. Standard A176 and Tentative Standard A193-T, and castings by A221.

**HARDENABLE STAINLESS IRONS** The low-carbon (0.10%) varieties are the least expensive of all the stainless steels, containing just enough chromium to impart stainless properties. Almost regardless of their condition they will resist corrosion from atmospheres, fresh, salt, and mine water, steam, oil and gasoline, perspiration, ammonia, soap and sugar solutions; and they will resist scaling in continuous operation at temperatures up to 1200 F (650 C).

Their machinability is poor because of the tendency of the chips to gall and seize on the tool, even though the chips can be separated quite readily. This galling and seizing may be decreased considerably, however, by proper tool grinding and by the use of high-sulfur oils. Annealing at 1300–1350 F (700–730 C), followed by air cooling, will give a hardness of about 170 Brinell, and the best average machinability. The metallographic structure in the annealed condition is predominantly ferritic as illustrated in Fig. 424a. For cleaner cutting, cold-working or the use of lower annealing temperatures will give somewhat better hardnesses. The machinability may be increased materially by the addition of about 0.3% sulfur or selenium, along with 0.60% (max) molybdenum to form molybdenum sulfide in some examples (A.I.S.I. Type 416). These additions reduce the seizing and galling characteristics of the alloy and, possibly, also assist in chip formation. The metallographic structure of one of the free-machining varieties is shown in Fig. 424e.

The alloys may be worked readily, both hot and cold, and welded. Care must be taken in working or welding because they air-harden progressively as the temperature increases above 1500 F (820 C) even though they do not become brittle. The proper forging temperature is 2100 F (1150 C); and the alloys harden to 375–400 Brinell by oil quenching from a soak at 1700–1800 F (930–980 C) even though they also will harden to a lesser extent on air cooling. The metallographic structure in the hardened condition is shown in Fig. 424b.

The effects of tempering a 1-in. round for 1 hr at various temperatures

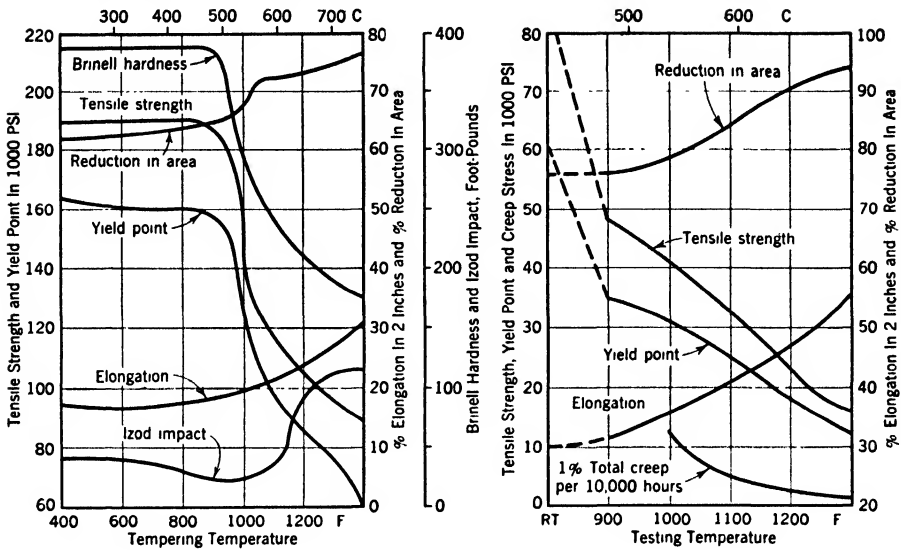


FIGURE 422. (Left) Effect of tempering temperature on the tensile properties of a 1-in. round of 13% chromium steel containing 0.1% carbon, after oil quenching from 1700 F (930 C). (Courtesy The Carpenter Steel Company.)

FIGURE 423. (Right) Tensile properties at elevated temperatures of an annealed 13% chromium steel containing 0.1% carbon. (Courtesy The Carpenter Steel Company.)

after oil quenching from 1700 F (930 C) are indicated in Fig. 422. Likewise, the retention of properties at temperatures up to 1300 F (700 C) is shown in Fig. 423.

Alloys of this type are used widely for valves and valve seats, particularly those subjected to high- and low-pressure steam, high temperature bolts, and shafting for use under corrosive conditions, as well as for purely ornamental purposes. One of the most important applications has been for blades or buckets in steam turbines, covered by U. S. Navy Specification 46-S-12d, class *a*.

The alloy also finds some use for electrical resistance purposes, especially with the addition of up to 3.5% aluminum to raise the specific resistance and lower the temperature coefficient. In addition, the aluminum increases the scale resistance to some extent. This modification of the alloy cannot be hardened by heat-treatment, however.

Small amounts of both molybdenum and tungsten sometimes are added to increase the high-temperature strength.

Among the trade names under which the hardenable stainless irons are sold may be mentioned *Carpenter 1* and *5*, *Allegheny 12* and *12 EZ*, *Ohmaloy*, *Arco 13*, *Bethadur 403*, *410*, and *Bethalon 416*, *Duro-Gloss C1*

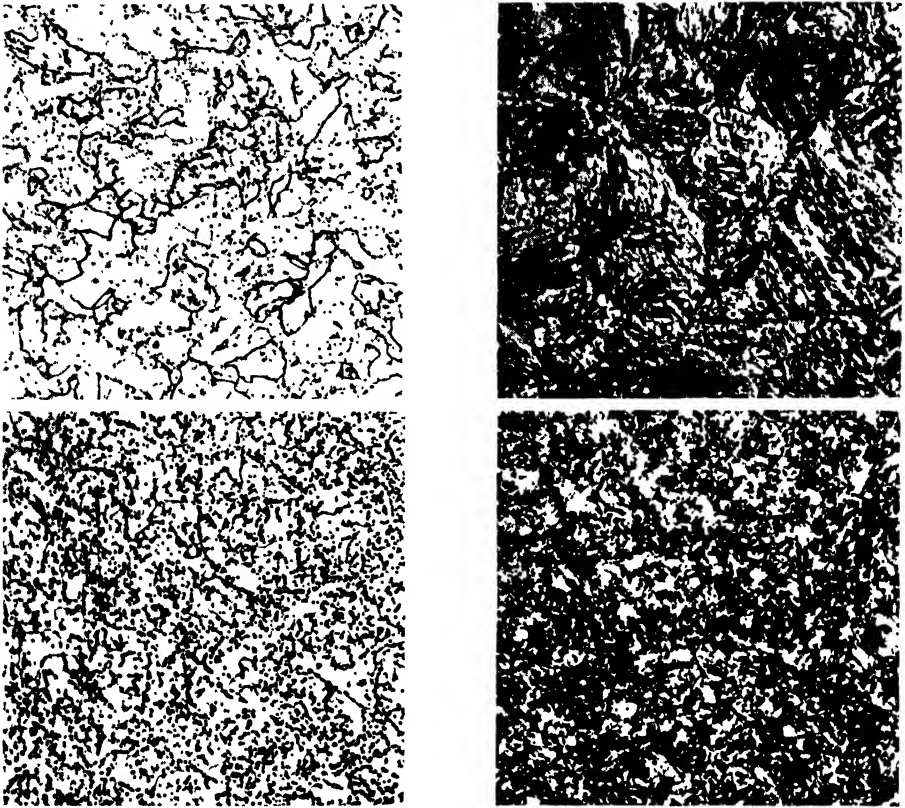


FIGURE 424. Metallographic structures of the 13% chromium hardenable-type stainless steels. (Photomicrographs courtesy Rustless Iron and Steel Corporation, Baltimore, Maryland.)

*a. (Top left)* Hardenable stainless iron (12% Cr - 0.12% C - rem. Fe), annealed. Carbides of iron and chromium in a ferritic matrix. Hardness about 160 Brinell. Etched with hydrochloric-picric acid reagent.  $\times 500$ .

*b. (Top right)* Hardenable stainless iron (12% Cr - 0.12% C - rem. Fe), hardened to about 400 Brinell. Martensitic. Etched with hydrochloric-picric acid reagent.  $\times 500$ .

*c. (Middle left)* Standard cutlery-type stain-

less steel (13% Cr - 0.35% C - rem. Fe), annealed. Carbides of iron and chromium in a ferritic matrix. Hardness about 180 Brinell. Etched with hydrochloric-picric acid reagent.  $\times 500$ .

*d. (Middle right)* Standard cutlery-type stainless steel (13% Cr - 0.35% C - rem. Fe), hardened. Carbide particles in a martensitic matrix. Hardness about 555 Brinell. Etched with hydrochloric-picric acid reagent.  $\times 500$ .

*e. (Bottom left)* Free-cutting type stainless iron (12% Cr - 0.10% C - 0.30% S - rem. Fe). Gray sulfide particles have been elongated during hot-rolling. Unetched.  $\times 250$ .

and *F.M.*, *Stainless "I,"* Type "*T*" and "*FCT*," *Lesco L* and *LS*, *Midvaloy 13-00*, *Enduro S-1* and *FC*, *Defirust*, *Rustless 12* and *12FM*, *Uniloy 1409* and *1409-M*, and *USS 12* and *12FM*.

**CUTLERY TYPE** The cutlery-type stainless steels (A.I.S.I. Type 420) are used principally for cutlery, surgical and general instruments, scissors, rules and straightedges, gauges, needle valves, gears, shafts, cams, pivots, and ball bearings, as well as for springs and valves and other parts for use at elevated temperatures. They also make fair permanent magnets, about 65% as good as chromium magnet steel. However, they should not be used for springs or other stressed parts operating at subzero temperatures because their shock resistance falls off rapidly as the temperature decreases.

Alloys of this type should not be used in the annealed condition because only hardening can bring out their corrosion-resisting properties, i.e., there must be as few free carbides as possible if the material is to be corrosion resistant. If the mechanical properties produced by heat-treatment are not required, then the alloy has been improperly specified and one of the hardenable stainless irons or one of the other types should be used. When hardened and polished properly, the cutlery-type stainless steels have about the same corrosion resistance as the low-carbon variety with the same chromium content.

After oil quenching from 1825 F (1000 C) the Brinell hardness will be about 512 and the Rockwell hardness C52–53, with the metallographic structure shown in Fig. 424*d*. After tempering at 1000 F (540 C) these hardnesses will decrease to Brinell 401, Rockwell C43. Higher drawing temperatures seldom are used for this alloy, because it is better to use the low-carbon variety if lower hardnesses are necessary. After annealing, by furnace cooling from about 1450 F (790 C), the alloy will have a Brinell hardness of about 196, and the metallographic structure shown in Fig. 424*c*.

The addition of about 0.30% sulfur or selenium increases the machinability appreciably (A.I.S.I. 420F or S.A.E. No. 51410) and also gives certain nongalling and nonseizing properties which are valuable in some types of service.

The cutlery-type steels are sold under the names *Carpenter 2*, *Allegheny L-12*, *Bethadur 420*, *Grade "A,"* Type "*A*," *Sta-Gloss A*, *Regular S.S.*, *Midvaloy 13-00A*, *Enduro S-Hi Carbon*, *Rustless 13-C-35*, and *Uniloy 1435*, among others.

A modified cutlery steel containing about 16.5% chromium and 0.60–1.00% carbon (A.I.S.I. Type 440), works much the same as the standard grades, but gives a more intense hardness and a better cutting edge. These modified alloys are sold under the brand names *Bethadur 440*, *Carpenter*

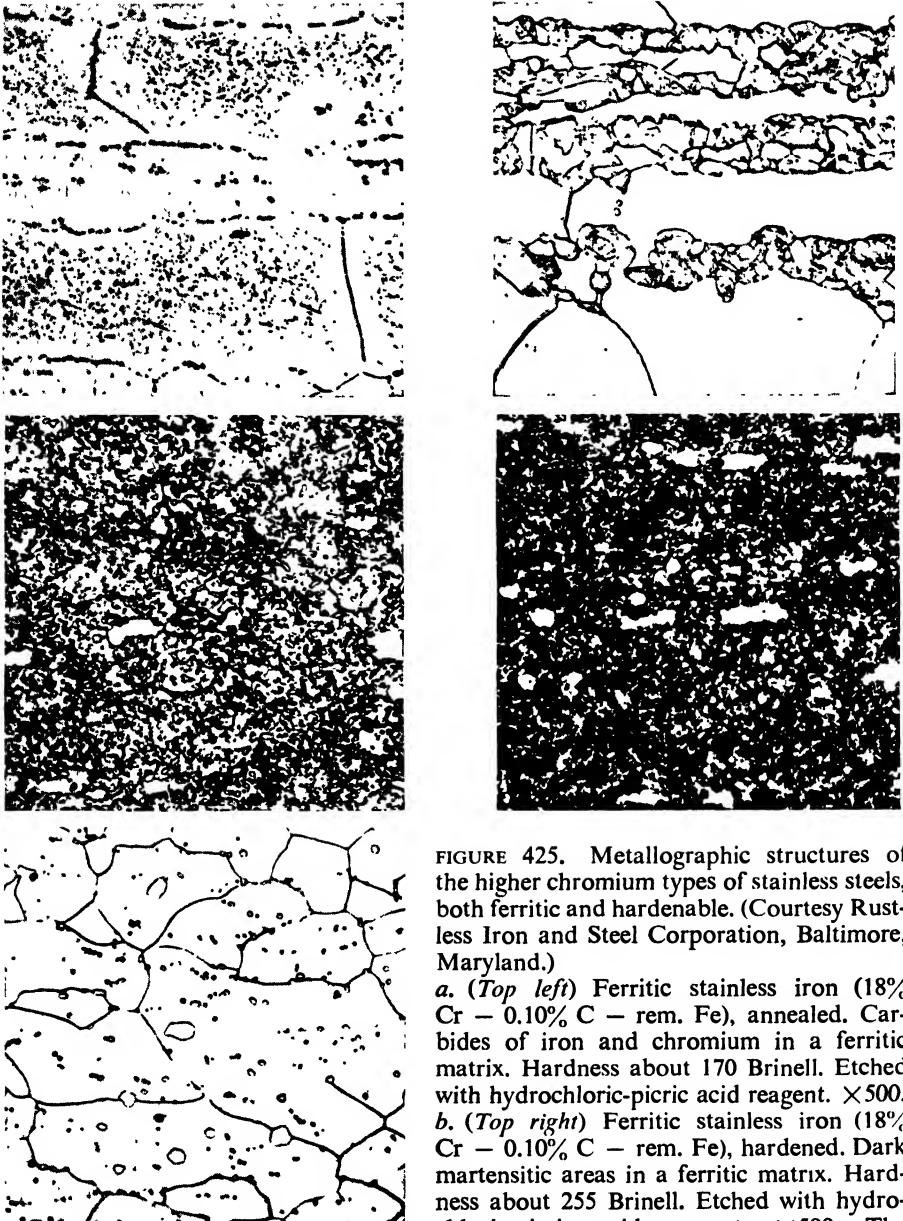


FIGURE 425. Metallographic structures of the higher chromium types of stainless steels, both ferritic and hardenable. (Courtesy Rustless Iron and Steel Corporation, Baltimore, Maryland.)

*a. (Top left)* Ferritic stainless iron (18% Cr - 0.10% C - rem. Fe), annealed. Carbides of iron and chromium in a ferritic matrix. Hardness about 170 Brinell. Etched with hydrochloric-picric acid reagent.  $\times 500$ .  
*b. (Top right)* Ferritic stainless iron (18% Cr - 0.10% C - rem. Fe), hardened. Dark martensitic areas in a ferritic matrix. Hardness about 255 Brinell. Etched with hydrochloric-picric acid reagent.  $\times 500$ . The

amount of martensite formed is so small that its hardening effect is negligible.  
*c. (Middle left)* Modified cutlery-type stainless steel (17% Cr - 1.0% C - rem. Fe), annealed. Large carbide particles in a ferritic matrix. Hardness about 200 Brinell. Etched with hydrochloric-picric acid reagent.  $\times 500$ .  
*d. (Middle right)* Modified cutlery-type stainless steel (17% Cr - 1.0% C - rem. Fe), hardened. Large carbide particles in a martensitic matrix. Hardness about 627 Brinell. Etched with hydrochloric-picric acid reagent.  $\times 500$ .

#2-B, Allegheny M-17 and H-17, Stainless "B," "BH" and "BHH," Sta-Gloss B, Hyglo Lusterite, Enduro AA-Hi Carbon. Rustless 17-C-60, 17-C-80, 17-C-100, and Uniloy 18100-1860, among others. Whereas the standard type of cutlery steel would be almost entirely pearlitic after very slow cooling, these modified types will have an appreciable amount of free carbide in their microstructure as illustrated in Figs. 425c, d and 507. They are also sold as tool steels although usually with a much higher carbon content and, as such, are discussed further in Chap. XVIII.

Castings, which correspond closely in composition to the wrought alloys, are made of both varieties of the hardenable-type stainless steels. About 0.5–1% nickel usually is added to the casting alloys to increase the tensile and yield characteristics. Although surfaces in the rough cast condition are more susceptible to stain and rust spots than when smooth and polished they do resist progressive corrosion of an oxidizing character. Because free carbides cause a deterioration in corrosion resistance, castings should not be tempered above 900 F (480 C) if maximum resistance to corrosion is desired.

#### THE FERRITIC ALLOYS

The nonhardenable ferritic stainless steels are also frequently considered to be stainless irons since they contain 0.1% carbon or less. The higher carbon forging alloys, in which iron is alloyed with 17% chromium and about 0.6–1.0% carbon are hardenable and have, therefore, been discussed previously with the cutlery-type stainless steels. Typical metallographic structures of both groups are illustrated in Fig. 425.

The alloy containing 17% chromium and 0.1% carbon (A.I.S.I. Type 430 or S.A.E. No. 51710) lies near the lower limit of this group and resists about the same corrosive conditions as the 13% chromium alloy, but with a greater factor of safety because of the higher chromium content. When the surface is prepared properly it is nearly untarnishable, and it is recommended to resist corrosion from atmospheres, fresh water, foodstuffs, nitric acid, milk and dairy products, and many other media. *Carpenter #6, Allegheny 17, Armco 17, Bethadur 430, Stainless "C-2," Type "M," Duro-Gloss C2, Midvaloy 17-00, Enduro AA, Rustless 17, and Uniloy 1809* are some of the names under which this type of steel is sold commercially. Many alloys of this type are also included in A.S.T.M. Standards A176 and A221 (castings).

---

e. (Bottom left) Ferritic stainless steel (27% Cr – 0.20% C – rem. Fe), annealed. Carbides of iron and chromium in a ferritic matrix. Hardness about 170 Brinell. Etched with hydrochloric-picric acid reagent.  $\times 500$ .



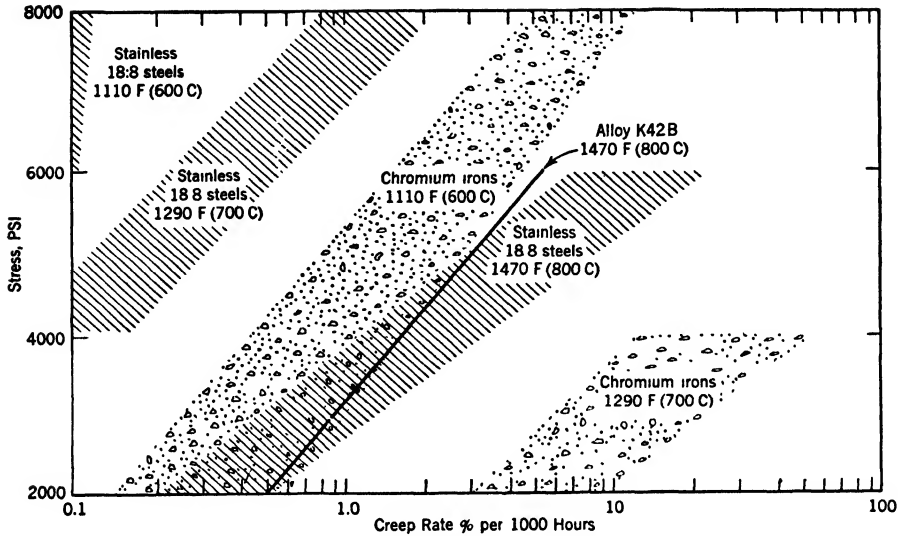


FIGURE 426. Comparative effects of temperature on the approximate distribution of the stress-deformation relationship for 18:8 stainless steels and chromium irons (8.5 – 24.5% chromium, low nickel). A curve for the heat-resisting alloy K42B (46% Ni – 25% Co – 19% Cr – 7.5% Fe – 2.5% Ti), which is referred to later in this chapter (cf. Fig. 455), also is shown for comparison. (From C. R. Austin and H. D. Nickol, *Journ. Iron & Steel Inst.*, London, 137, 1938, 177–221.)

These ferritic alloys work-harden much less than the austenitic alloys. In the hard-rolled condition, tensile strengths of 110,000–120,000 psi, with yield points of 106,000–112,000 psi, and Rockwell hardnesses of B98–105 are all that can be secured in strips readily. The strength of the annealed material is lower, averaging about 70,000–75,000 psi, with a yield point of 45,000–55,000 psi, and elongation of 32% in 2 in., a reduction in area of 35%, and a hardness of 150 Brinell or Rockwell B80. The creep resistance of these alloys is fair, but appreciably poorer than that of the austenitic alloys. The order of magnitude of this difference is illustrated diagrammatically in Fig. 426, for the three temperatures 1110 F (600 C), 1290 F (700 C), and 1470 F (800 C).

The addition of more than about 0.5% silicon generally is considered to be undesirable because it decreases the toughness and impact strength. However, in amounts greater than 1%, silicon increases to some extent both the resistance to cold oxidizing acids and the resistance to scaling at elevated temperatures, so the requirements of the application must be the determining factor.

Sulfur (0.35%) and molybdenum (0.30%) (A.I.S.I. Type 430F) are added to increase the machinability over that of the plain chromium iron, their combination, molybdenum sulfide, probably being the actual con-

stituent which decreases galling and seizing and facilitates chip formation. Selenium (0.35%) also is added for this purpose.

If an even better resistance to corrosion and scaling is desired, the chromium content can be increased to 20% or higher. A minimum of 20% chromium seems to be necessary to form a self-healing layer of oxide on continued exposure at elevated temperatures. This alloy, like the others of this group, can be hardened only by cold-work and work-hardens about like ordinary mild steel, i.e., relatively slowly. It can be annealed to a Brinell hardness of about 180 by cooling rapidly from 1500 F (820 C). This higher chromium alloy falls within the limits of A.I.S.I. Type 442 which is sold commercially under the names *Carpenter #3* and *#6-20*, *Allegheny 21*, *Bethadur 442*, *Stainless #20*, *Duro-Gloss C3*, *Lesco "H," Rustless 21*, and *Uniloy 2009*, among others.

The addition of about 1% copper to this higher chromium alloy appears to increase somewhat the resistance to corrosion by salt water and non-oxidizing acids. Furthermore, it raises the proportional limit about 20% without changing the other strength properties, thus giving a better elastic ratio, and makes the alloy respond more uniformly to heat-treatment, even though somewhat higher temperatures must be used than with the alloy containing no copper.

#### SILCHROME

The original alloy *Silchrome*, containing 0.45% carbon, 8.25% chromium, 3.5% silicon, and the remainder iron, has been extensively used for exhaust valves in internal combustion engines, especially aircraft engines.<sup>13</sup>

In many of these valves the heat dissipation is materially improved by using a hollow valve containing metallic sodium or a suitable salt mixture, which melts at the valve head and splashes about, thus transferring heat directly to the cooler stem (Fig. 427).

#### HIGH (25-30%) CHROMIUM IRONS

Chromium contents as high as 30% are used for both cast and wrought alloys for applications in which extreme resistance to scaling at elevated temperatures is required, and the higher cost can be justified. For example, alloys in the range 26-28% chromium will maintain their surfaces indefinitely when exposed to oxidizing conditions up to 1950-2000 F (1065-1095 C) even under extreme changes in temperature. Even reducing atmospheres have little effect up to this limit, although they lead to

<sup>13</sup> This is discussed by H. D. Budd, Jr. in Chap. 16B of Ref. 1 at the end of this chapter.

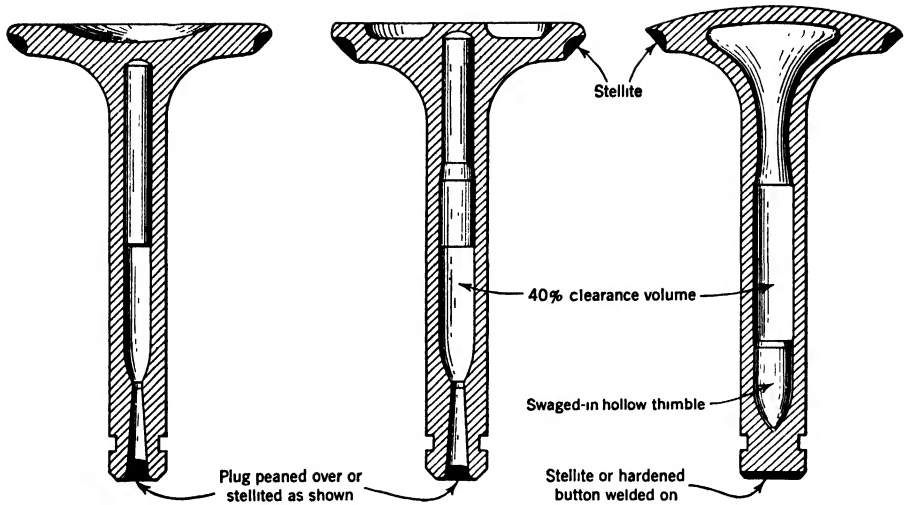


FIGURE 427. Three types of sodium-cooled exhaust valves. The two at the left have their hollow stems peened over, or stellite as shown in order to close them. Sodium, or a salt which melts at about the temperature of boiling water, is placed in the stem and splashes about, thus carrying heat rapidly from the hot head to the cooler stem. The type at the right is a more recent design incorporating not only a hollow head, which increases the cooling efficiency for this part, but also a swaged-in hollow thimble which limits the volume in which the coolant moves. In some engines it is necessary to keep the retainer and tappet parts as cool as possible so some such method must be used to restrict the heat flow to this portion of the valve. (After D. R. Pye, *Journ. Inst. Metals*, London, 51, 1937, 19-34.)

deterioration at higher temperatures; and sulfur-bearing gases, as well as the oxides of nitrogen, have little effect up to 1800 F (1000 C). This resistance to scaling and oxidation makes the alloys very useful for recuperators, heat exchangers, baffles, "water walls" in power plants, and similar installations where combined corrosion and heat resistance are required.

The carbon content of the wrought alloys usually is kept below 0.35% because alloys with higher carbon contents tend to be sufficiently hard to have undesirable hot-working qualities. The metallographic structure of the wrought alloys in the annealed condition, i.e., rapid cooling from a soak at 1550-1650 F (840-900 C), is similar to the example shown in Fig. 425e. Some of the commercial names for the lower carbon alloys of this chromium range (A.I.S.I. Type 446) are: *Allegheny 28*, *Armco 27*, *Bethadur 446*, *Duro-Gloss C4*, *Lesco "HH,"* *Midvaloy 26-02*, *Enduro HC*, *Defiheat*, *Cimet*, and *Uniloy 2825*. These alloys are also covered by A.S.T.M. Standards A176 and A221 (castings).

These high-chromium irons will develop tensile strengths, in the annealed condition, of about 75,000-95,000 psi, with a yield strength of 45,000-

60,000 psi, an elongation of 20–30% in 2 in. , and a reduction in area of 40–50%. By cold-rolling the fully annealed materials the strengths can be increased appreciably.

In castings of this type, carbon contents up to 3% do not seem to affect the high-temperature oxidation resistance materially. A possible explanation of this is that, at temperatures above those at which oxidation would tend to occur in these alloys, viz., about 1650 F (900 C), the carbon is incapable of holding sufficient chromium in the combined condition to affect the oxidation resistance.

The machinability of these higher carbon casting alloys may be improved by heating to 1475 F (800 C) and cooling slowly to at least 1100 F (600 C). The rate of cooling below this temperature seems to have little effect.

Modifications of these high-chromium wrought alloys which possess greater toughness and somewhat better corrosion resistance under some conditions, are A.I.S.I. Types 327 and 329, typical examples of which are sold commercially under the names of *Carpenter 7* and *7-Mo*, and *Rezistal 329*. In the first type (A.I.S.I. 327) about 4.5% nickel is added, and in the second (A.I.S.I. 329) about 4.5% nickel and 1.5% molybdenum.

The modification containing molybdenum is susceptible to precipitation hardening, the recommended treatment being a furnace cool after a 48-hr soak at 1350 F (730 C). This will make the alloy nonmagnetic with a hardness of 375–425 Brinell or Rockwell C40–45. Although the corrosion resistance is not affected by this treatment the alloy becomes almost as brittle as cast iron, a characteristic which is not too desirable for some applications. By water quenching from about 1700 F (930 C) the alloy can be annealed to about 230 Brinell, with other mechanical properties, except for the higher shock resistance, comparable to those of the straight chromium alloys.

#### THE AUSTENITIC STAINLESS STEELS OF THE 18:8 TYPE

The addition of 18% chromium to iron permits ferrite to exist at all temperatures, i.e., gives an alloy of the type possessing a closed gamma loop. Upon subsequent addition of more than 3% nickel to this base alloy the gamma phase becomes stable in the vicinity of 1475–1830 F (800–1000 C) and the alloys can be made austenitic in nature by heating to this region whenever the inevitable carbon is present. By increasing the nickel content the range of austenite stability can be increased but, regardless of the nickel content, some ferrite will always be present at room temperature unless nitrogen is present in appreciable amounts.<sup>14</sup> However, since

<sup>14</sup> See H. H. Uhlig, *Trans. A.S.M.*, 30, 1942, 947–979.

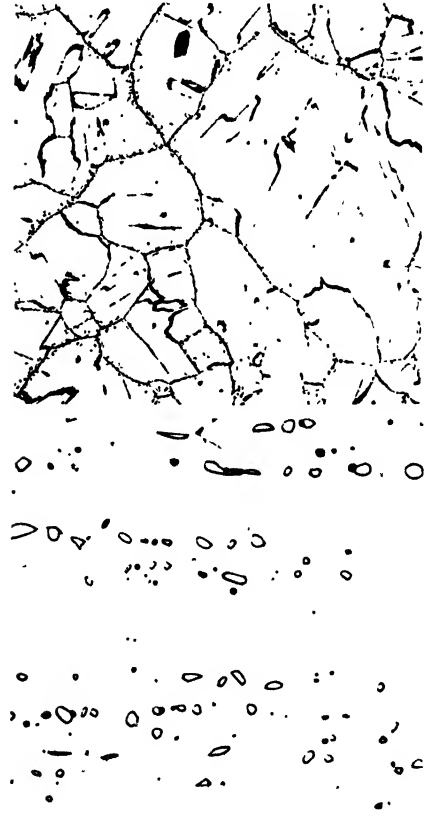
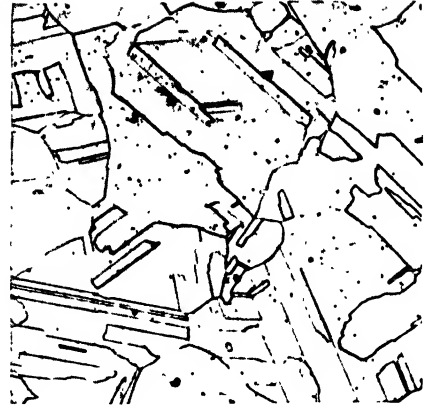
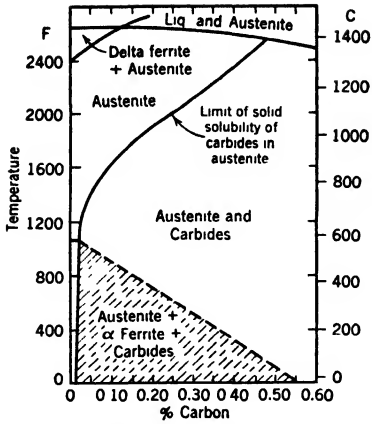


FIGURE 428. (Top left) Probable nature of solid solubility limits (solvus line) in steels alloyed with 18% chromium and 8% nickel. (After R. H. Aborn, E. C. Bain, and others.)

FIGURE 429. Metallographic structures of 18:8 type austenitic stainless steels. a. (Top right) After quenching from 2100 F (1150 C). Etched electrolytically with 2½% oxalic acid.  $\times 100$ .

these chromium-nickel-iron alloys usually are prepared commercially under atmospheres which contain nitrogen, viz., air or modified air, the commercial 18% Cr-8% Ni-rem. Fe alloy, which is the most important member of the group, almost invariably will be completely austenitic. Carbon influences the constitution to some extent since it is almost always present in commercial melts and tends to form complex carbides of iron and chromium. The general nature of its effect on the basic austenitic 18:8 alloy is indicated in the diagram of Fig. 428.

Commercially, the carbon content of the 18:8 type stainless steel alloys is kept in the range 0.08-0.20% (A.I.S.I. Type 302) depending upon the application, although a lower carbon type, 0.08% max (A.I.S.I. Type 304) is available to provide a better material for welding. In either of these alloys, quenching from above about 1750 F (950 C) will retain all of the carbides in solid solution and give the typical twinned austenitic structure shown in Fig. 429a. The usual commercial anneal consists of rapid cooling from the range 1750-2100 F (950-1150 C). By reheating at temperatures below the solid solubility line for times which are dependent upon the temperature, e.g., relatively short times for higher temperatures and long times for lower ones, a precipitation of chromium-iron carbides will occur at the grain boundaries (Fig. 429b and c). By working at elevated temperatures or by cold-working and then reheating below the solid solubility line the precipitate will tend to occur instead along the slip planes of the solid solution (Fig. 429d), probably those along which deformation occurred. During this process some transformation of nonmagnetic gamma into magnetic alpha ferrite, containing nickel and chromium in solid solution, may also take place.<sup>15</sup> In order to dissolve these carbides, and any ferrite which has been formed, the material must again be quenched from

<sup>15</sup> This is discussed well by R. H. Aborn and E. C. Bain, *Trans. A.S.S.T.*, **18**, 1930, 837-873; and by R. Buehl, H. Holloman, and John Wulff, *Trans. A.I.M.E.*, **140**, 1940, 368-384.

*b. (Middle left)* After quenching from 1950 F (1065 C) and reheating 15 min at 1725 F (940 C). Coarse carbides precipitated at grain boundaries by heating just under solvus temperature. Etched electrolytically with 2½% oxalic acid. ×750.

*c. (Middle right)* After quenching from 1950 F (1065 C) and reheating 1900 hr at 1300 F (705 C). Fine carbides precipitated near grain boundaries and the edges of annealing twin bands. Etched electrolytically with 2½% oxalic acid. ×100.

*d. (Bottom left)* After quenching from 1950 F (1065 C), cold-working, and reheating 1 hr at 1000 F (540 C). Carbides have precipitated along slip planes. Etched with mixed acids in glycerol. ×500.

*e. (Bottom right)* Free ferrite formed by the addition of molybdenum to the 18:8 alloy. Etched with mixed acids in glycerol. ×500.

(Photomicrographs *d* and *e* courtesy Rustless Iron and Steel Corporation, Baltimore, Maryland.)

the solid solution temperature range. This will restore the austenitic structure.

It must be emphasized that the basic 18:8 alloy, although having a constitutional diagram similar to those of precipitation-hardening alloys, is not itself susceptible to precipitation hardening since the carbides precipitate selectively at the grain boundaries or along the active slip planes instead of uniformly throughout the grain as is the case in the majority of the precipitation-hardening alloys.<sup>16</sup>

Both A.I.S.I. Type 301 (16–18% Cr, 7–9% Ni) and Type 302 (18–20% Cr, 8–10% Ni) are known as 18:8 alloys although 302 more commonly is made and used than 301, which is primarily a sheet alloy intended for cold-rolling. The 18:8 alloy is sold under a wide variety of brand names among which are *Carpenter #4*, *Allegheny Metal 18-8*, *Armco 18-8*, *Bethadur 302*, *Rezistal KA2*, *Stainless "N,"* *Nirosta KA2*, *Hi-Gloss*, *Lesco 18-8*, *Midvaloy 18-08*, *Enduro 18-8*, *Defistain*, *Uniloy 18-8*, *Rustless 18-8*, and *USS 18-8*. Certain grades covered by S.A.E. Nos. 30905 and 30915, and A.S.T.M. Standard A167, Tentative Standard A193-T are also of this type. For sheet, strip, and plate for fusion-welded unfired pressure vessels, A240 applies, and A198 covers castings.

Many of the applications of the 18:8 type alloys, particularly in sheet form, depend upon their excellent work-hardening characteristics. These will be discussed in Chap. XVI.

#### SENSITIZATION

The austenitic solid-solution form of the alloy is resistant to a very large number of corroding media, although it is by no means uncorrodable. Moreover, once the alloy is sensitized<sup>17</sup> by the precipitation of grain boundary carbides it loses a large part of its corrosion resistance, and becomes extremely susceptible to grain boundary attack. This susceptibility can be shown readily by boiling in Strauss solution, viz., 47 ml H<sub>2</sub>SO<sub>4</sub> (sp gr 1.84) and 13 g CuSO<sub>4</sub>·5H<sub>2</sub>O per 1000 ml of solution. The treatment in Strauss solution causes no loss in weight with normal (unsensitized) metal, but produces severe intergranular attack upon sensitive material. This is well illustrated metallographically in Fig. 430. Although the reasons for this susceptibility are not entirely known, the idealized diagram shown in Fig. 431 gives a satisfactory explanation. According to this explanation a minimum of about 12% chromium is needed to impart corrosion resis-

<sup>16</sup> Age-hardenable grades are in process of commercial development, but at this time only the small amount of information given later in this section is available.

<sup>17</sup> This is discussed thoroughly by E. C. Bain, R. H. Aborn, and J. J. B. Rutherford in Chap. 14B of Ref. 1 at the end of this chapter.

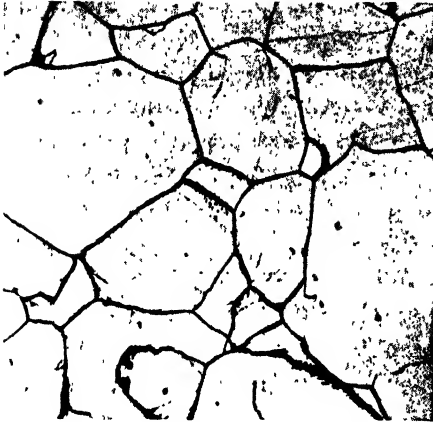


FIGURE 430. Microstructure of disintegrated metal after sensitization and corrosion.  $\times 100$  originally; reduced about one third in reproduction. (Photomicrograph courtesy U. S. Steel Corporation Research Laboratory, Kearny, N. J.)

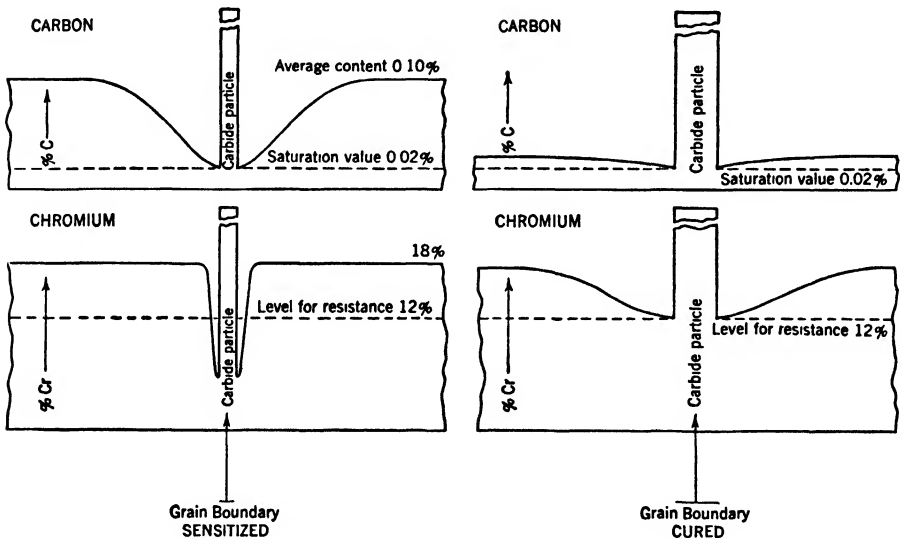


FIGURE 431. Idealized diagram showing probable distribution of carbon and chromium concentration (ordinate) in the vicinity of a carbide particle. Abscissa is merely distance on either side of the grain boundary.

*Left*, soon after precipitation, the alloy is sensitized.

*Right*, after sufficient approach to equilibrium to restore grain boundary corrosion resistance.

(Courtesy U. S. Steel Corporation Research Laboratory, Kearny, N. J.)

tance to the alloy. When the austenitic structure exists with no free precipitated carbides, the chromium content is well over this limit and corrosion is resisted either by the formation of a very thin protective oxide film or by passivation. However, when carbide precipitation occurs, the particles seem to be predominantly chromium carbide,  $Cr_4C$ , so the regions adja-



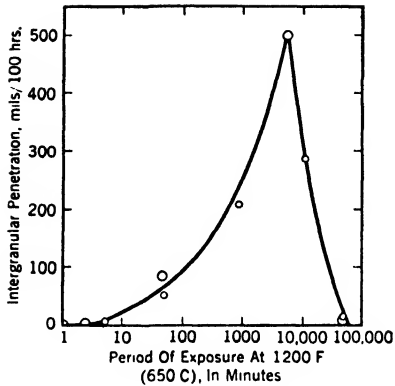


FIGURE 432. Sensitization and restoration at 1200 F (650 C) in 18:8 containing 0.08% carbon. Different specimens of the alloy were held at temperatures for the times shown and then corrosion tested, intergranular penetration being measured. Note that after about 100 hr (6000 min) at temperature, the subsequent penetration begins to decrease. This brings out clearly the important fact that sensitization inevitably is followed by restoration if enough time is given at constant temperature. (Courtesy U.S. Steel Corporation Research Laboratory, Kearny, N. J.)

the proper temperatures, as illustrated for 1200 F (650 C) by Fig. 432.

#### PREVENTION OF SENSITIZATION

There are four possible methods for preventing the loss of corrosion resistance resulting from sensitization:

1. Reduction of the carbon content to the solubility limit of about 0.02%.
2. Restriction of the use of the alloy to temperature ranges in which carbide precipitation will not occur.
3. Dispersion of carbides throughout the grains by means of cold-work, which causes the precipitation to occur along slip planes during the subsequent reheating instead of at the grain boundaries.
4. Addition of carbide-forming elements which will replace the chromium in the initial precipitate, and thus leave it available for maintaining the corrosion resistance.

The first of these is impractical from a commercial viewpoint at the

cent to these particles are depleted both in carbon and, more important, in chromium, thereby becoming susceptible to corrosive attack. Since carbides precipitate predominantly at the grain boundaries, the grain boundary regions are depleted to the greatest extent and are, therefore, attacked most rapidly. When the alloy is held at the precipitation temperature for longer times two things apparently occur:

1. The carbides grow in size, removing carbon from the surrounding regions, and thereby preventing carbide precipitation in them.
2. Chromium diffuses from the surrounding regions to the grain boundary regions thus tending to equalize the concentration and to restore the amount needed for corrosion resistance.

As a consequence of these factors, the resistance to corrosion is returned if the heating is carried out long enough at

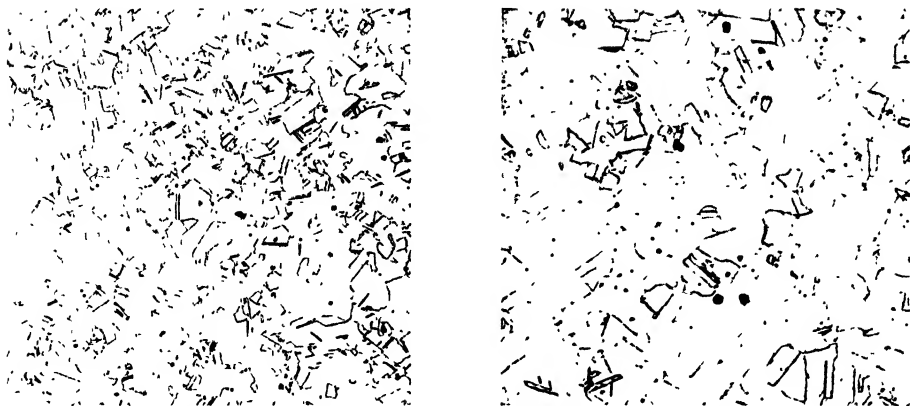


FIGURE 433. Metallographic structure of a stabilized 18:8 stainless steel containing a maximum of 0.08% carbon and at least ten times as much columbium as carbon. Etched with oxalic acid to bring out both carbides and grain boundaries.

*Left*,  $\times 100$ . *Right*,  $\times 500$ .

(Courtesy Union Carbide and Carbon Research Laboratories, Inc., Niagara Falls, N. Y.)

present time because there is always some carbon pickup from scrap, alloying elements, or electric furnace electrodes if this steelmaking process is used. However, alloys with a carbon content as low as 0.03% have been made successfully and seem to be quite free from the intergranular precipitation and deterioration.

The second would mean elimination of the alloy from many applications in which it has enjoyed widespread use as a result of the successful operation of the other two methods.

The use of cold-work to disperse the carbides throughout the grains, by precipitation along slip planes as shown in Fig. 429*d*, instead of at the grain boundaries, is quite feasible as long as the temperature of subsequent heating or use is in the range within which the precipitated carbides will not redissolve to any marked extent, viz., up to about 1400 F (760 C).

The most successful method of eliminating sensitization has been to add strong carbide-forming elements such as titanium (A.I.S.I. Type 321) or columbium (A.I.S.I. Type 347) to the base alloy.<sup>18</sup> The amount added should be at least five times the carbon content for titanium additions and at least ten times the carbon content for columbium additions. In these stabilized alloys carbide precipitation will still occur but as a random precipitate within the grains instead of as a continuous pattern at the grain boundaries. This is illustrated in Fig. 433 for an alloy stabilized with columbium.

<sup>18</sup> See F. M. Becket and R. Franks, *Trans. A.I.M.E.*, **113**, 1934, 143-156, for further comment.

If welds are made in the 18:8 alloy it is advisable to use one of the stabilized modifications for the base metal, unless the entire part can be annealed after welding. Otherwise, there is almost certain to be a sensitized zone adjacent to the weld zone, which must be adequately protected (cf. Fig. 465) if corrosion is not to result. In addition, if the fabricated article is to be used within the dangerous temperature zone of 1000–1500 F (540–820 C), a welding rod containing columbium or molybdenum should be used in order to stabilize the weld metal properly also. If a titanium bearing rod is used, most of the titanium is lost in the melting of the rod so this method is not satisfactory.

#### OTHER MODIFIED 18:8 ALLOYS

The addition of 2–3% silicon to the 18:8 base (A.I.S.I. Type 302B) gives one of a class of steels which were sold originally under the general trade name *Rezistal*,<sup>19</sup> although the specific name *Rezistal 2C* now is used instead. The materials containing silicon have a somewhat higher hardness, and are much more resistant to scaling at elevated temperatures (for some applications, up to 1700 F (930 C)) than the plain alloy.

Tungsten sometimes is added to the 18:8 base alloy both to increase resistance to intergranular attack, and to increase the high-temperature strength. Amounts of 1–5% have been used although molybdenum additions generally have been preferred to tungsten in this country. Tungsten additions seem to have little effect upon either chemical resistance or high-temperature scaling, however.

Molybdenum in amounts of 1–4% (A.I.S.I. Type 316) is the most generally useful alloy addition. It increases the magnitude of the resistance of 18:8 to the corrosive action of many chemicals, especially sulfurous acid compounds, and inhibits intergranular attack when used with a properly balanced analysis. Therefore, welding is made easier and safer. Molybdenum also raises the strength at elevated temperatures. However, the alloy is more expensive than ordinary 18:8, and is somewhat more difficult to fabricate. The addition of molybdenum also tends to give some free ferrite in the microstructure, as shown in Fig. 429e.

Selenium (0.15–0.30%) or sulfur (0.20–0.40%) (A.I.S.I. Type 303) is added to increase machinability, the former having less effect on ductility than the latter. These “free-cutting” modifications can be machined with all the usual machine-shop tools at speeds ranging from 60–70% of those of steel screw stock.

<sup>19</sup> These alloys are discussed thoroughly by C. M. Johnson in Chap. 16 of Ref. 1 at the end of this chapter.

## STRESS CORROSION CRACKING OF THE AUSTENITIC STAINLESS STEELS

Austenitic stainless steels are susceptible to stress corrosion cracking under certain corrosive environments irrespective of their susceptibility to intergranular corrosion. Although the reason for this is not known as yet, experience has shown that proper laboratory testing procedures aid materially in selecting alloys with a comparatively low susceptibility. Usually, heated chloride solutions are found to be most satisfactory to work with in laboratory testing.

In the austenitic alloys stress corrosion cracks, apparently, can be either inter- or transgranular depending upon the corrosive medium, the susceptibility of the alloy to intergranular attack, and the stress conditions. Unfortunately, however, even when susceptibility to intergranular attack is minimized by any of the methods described above it is often found that a transgranular type of failure may still result. Sometimes also a crack may be initially transgranular and later change to intergranular.

It is fortunate, perhaps, in view of their widespread use for applications involving cold-rolled sheet, that the 17:7 (Type 301) stainless steels seem to be fairly resistant to stress corrosion failures under atmospheric conditions.

## PRECIPITATION-HARDENABLE 18:8 TYPE STAINLESS STEELS

Very little information is available as yet on the precipitation-hardening 18:8 type stainless steels developed during the war period. An alloy, sold commercially as *Stainless W*, however, is known to be of this type. It contains nominally, in addition to iron, 7% nickel, 17% chromium, 0.40–1.00% titanium, and about 0.20% aluminum and 0.50% manganese.

This is a carefully balanced composition and, consequently, the austenite to ferrite (martensite) transformation and the subsequent process of precipitation hardening takes place nearly completely without requiring any cold work. Titanium is the important element, serving both to effect the precipitation hardening and to facilitate the formation of ferrite, but columbium has been substituted for it successfully to give the same type of alloy. The amount of soluble titanium available for these purposes is, of course, controlled to some extent by the carbon content since titanium carbide is formed first. Aluminum serves both as a deoxidizer and as a means of augmenting the titanium precipitation hardening.

Solution annealing serves the usual purpose of putting all the hardening constituents in solid solution in austenite. Upon cooling to room tempera-

ture, the austenite transforms to a ferrite which is supersaturated with the precipitation-hardening constituent. After the austenite transformation is complete, aging at an elevated temperature for the proper time will increase the hardness to the extent desired.

The alloy has a Rockwell hardness of C22–28 in the annealed condition, with a tensile strength of 120,000–150,000 psi and a yield strength of 75,000–115,000 psi. After precipitation hardening, the hardness can be increased to C39–47, with a tensile strength of 195,000–225,000 psi and a yield strength of 180,000–210,000 psi.

Principal uses of the precipitation-hardening type stainless steel will be in applications such as cams and rollers in food handling equipment, bearings, valve parts, and similar applications in the oil, chemical, and food industries where a combination of hardness and corrosion resistance is essential.

#### CHROMIUM-NICKEL-MOLYBDENUM TYPE STAINLESS STEEL

The patented alloy containing 16% chromium, 13% nickel, 3% molybdenum, with the remainder essentially iron, is nearly twice as strong as the 18:8 type stainless steel alloys at elevated temperatures but still does not have the creep and rupture strengths needed, in the range 1200–1500 F (650–815 C), for certain applications, notably in turbo-superchargers, gas turbines, and jet engines. To meet these requirements, a more highly alloyed iron containing 15–17% chromium, 24–27% nickel, and 5.5–7% molybdenum was developed during World War II.<sup>20</sup>

In this alloy, the chromium imparts corrosion-and oxidation-resistance, the molybdenum high-temperature strength, and the nickel balances the composition so that a completely austenitic structure is secured. This is desirable because of the superior high-temperature strength of austenitic steels in comparison with the ferritic type. To improve the workability, up to 2% manganese may be added and additions of up to 1% silicon assist scale resistance materially. About 0.10–0.20% nitrogen is also usually present to assist in stabilizing the austenite.

Maximum ductility, indicative of complete carbide solution, is secured by quenching from above 2150 F (1180 C), but the highest yield and tensile strengths are found in hot-rolled material, although, since the upper limit for cold-work is about 1700 F (930 C), some of this improvement may be the result of low finishing temperatures during rolling. If the alloy is tempered for 12 hr in the range 1200–1600 F (650–870 C), it will precipitation-

<sup>20</sup> This material is discussed thoroughly, with numerous photomicrographs, by Martin Fleischmann, *Iron Age*, 157, 1946, Jan. 17, 44–53, Jan. 24, 50–60.

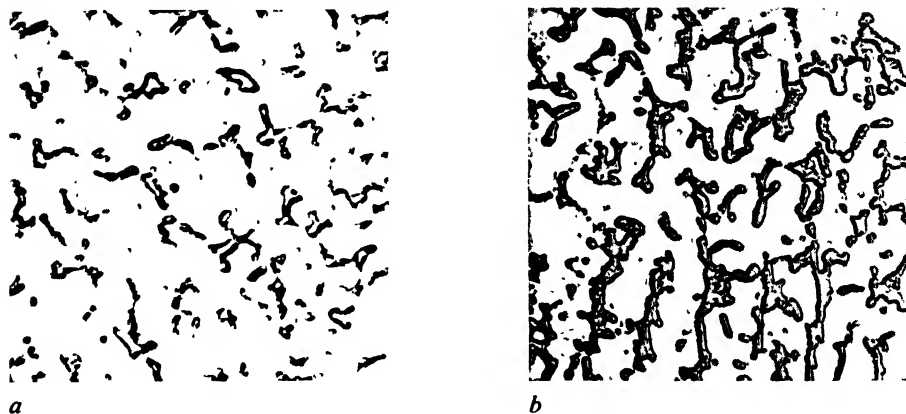


FIGURE 434. Metallographic structures of a cast heat-resistant alloy of the 29:9 type. Etched with aqua regia in glycerine.  $\times 100$  originally; reduced about one third in reproduction.

*a.* As cast.

*b.* After quenching in water from 2030 F (1110 C).

(Photomicrographs courtesy R. J. Wilcox, Michigan Steel Casting Company.) The matrix may be ferritic or austenitic, depending on the exact composition, the heat-treatments, and the casting conditions, without affecting the metallographic appearance appreciably. Some coring and particles of fine carbides can be seen.

harden, the Rockwell hardness increasing from about 5C to about 20C, and the yield strength increasing about 10% from about 52,000 psi to about 57,000 psi. The ductility values will drop simultaneously from an elongation in 2 in. of about 48% to about 32%, but even so they are still relatively good.

Both creep tests and stress-to-rupture tests indicate that the alloy is markedly superior to both 18:8 and the 16:13:3 alloy that it superseded.

Although this 16:25:6 alloy has not been used extensively as yet, it has shown its merit by the service it gave in gas turbine and jet engine turbine wheels, and in turbine blades during World War II. Many other applications for it undoubtedly will be found.

#### THE 29:9 CHROMIUM-NICKEL-IRON ALLOYS

The range 28–30% chromium, 8–10% nickel, and 0.2–0.3% carbon, with 0.55–0.75% manganese and 0.75–1.25% silicon, has been used successfully for the so-called 29:9 corrosion-resisting alloys (A.I.S.I. Type 312). These alloys are very resistant to intergranular attack, even in the cast condition, although their relatively high cost has been a deterrent to their use. By rapid cooling from 2000 F (1100 C) both the corrosion resistance and

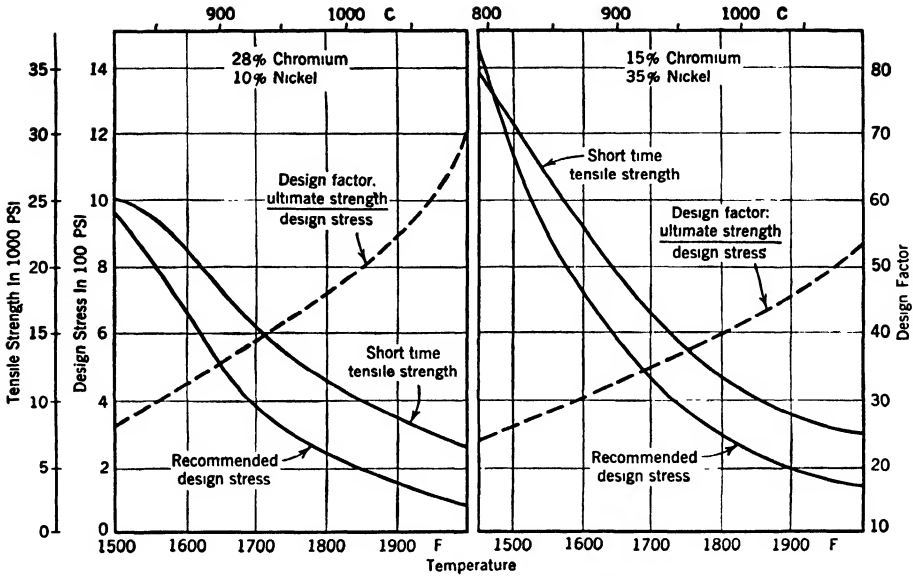


FIGURE 435. Short-time tensile strength and recommended design strength of 28:10 and 15:35 types of heat-resisting alloy castings in the range 1500–2000 F (820–1100 C). Read design stress against extended scale at left which gives data based on long observation of working parts, dependable for upward of 10,000 hr with negligible permanent deformation. (Courtesy R. J. Wilcox, Michigan Steel Casting Company.)

ductility can be further improved. These characteristics are desirable in applications for which heat-treatment after casting or welding may not be practicable. Typical metallographic structures are shown in Fig. 434 and some design stresses for use in the temperature range 1500–2000 F (820–1100 C) in Fig. 435. The alloy also is used in chemical roasting equipment and in furnaces where resistance to sulfur-bearing gases is required. Alloy steel castings of this composition are covered by A.S.T.M. Standard A222.

The corrosion resistance of this material is better than that of cast 18:8, and it has a somewhat higher yield and ultimate strength with somewhat lower ductility. In the as-cast condition a Rockwell hardness of B90–95 is typical, and the alloy has fair machinability. This can be improved, however, along with the nonseizing and nongalling characteristics, by suitable combinations of selenium (0.25%) and phosphorus (0.17%) or of molybdenum (0.60%) and sulfur (0.30%).

Stabilizing effects can be secured by the addition of suitable amounts of molybdenum, tungsten, titanium, columbium, or vanadium to the 29:9 analysis.<sup>21</sup>

<sup>21</sup> The engineering properties of these alloys are discussed in detail by H. S. Avery, E. Cook, and J. A. Fellows, *Trans. A.I.M.E.*, **150**, 1942, 373–394; and by J. T. Gow and O. E. Harder, *Trans. A.S.M.*, **30**, 1942, 855–919.

When an alloy is desired primarily for heat resistance, the carbon is increased to 0.3–0.6%, with chromium 26–30% and nickel 8–12% (A.S.T.M. Standard A222, Class C). This 28:10 alloy has a somewhat lower ductility than the 29:9 alloy, however.

#### THE 25:20 AND 15:35 CHROMIUM-NICKEL-IRON ALLOYS

Iron alloys containing, nominally, 25% chromium, 20% nickel (A.I.S.I. Type 310), and 15% chromium, 35% nickel (A.I.S.I. Type 330) will have high-temperature characteristics similar to but somewhat better than those of the 29:9 alloy. Some typical design stresses of the 15:35 alloy for various temperatures are also shown in Fig. 435. The higher nickel alloys have an excellent creep resistance, and are used for furnace construction where their comparatively high cost can be justified. The 25:20 alloy, in particular, has been used satisfactorily for the reaction tubes in the Pidgeon ferrosilicon process for magnesium (see Chap. IV), an extremely severe application.

Alloys of the 25:20 type are included in A.S.T.M. Standard A222 (Class B), and they are sold under many special trade names, in addition to 25:20, among which may be mentioned: *B. & W. #1100, 1101 and 1102, Rezistal #7, NCT-3, F-1824, Fahrte N-12, O-12, O-24, Enduro NC-3, Heat Res. #5B, Bethadur 310, and Tisco 109*. The 15:35 composition falls within the limits of A.S.T.M. Standard A223 (Class B) and is sold under the names: *B. & W. #1300, Rezistal #330, Calite A, Chromax, Thermalloy "50," X-B, Misco Metal, Zorite, Fahrte N-1, 36-N, and F-1*, among others, as well as the 15:35 or 35:15 designations, the 35:15 designation being more commonly used commercially than 15:35.

Depending upon the specific application, several variations in the standard compositions are made commercially and, in addition, many other combinations relatively high in both chromium and nickel are available for heat-resisting purposes. Most of these, however, are also fairly expensive as would be expected from their high alloy content and general characteristics. Microstructures typical of the cast 15:35 alloy are shown in Fig. 436. These are cored in the usual manner and in addition show precipitated carbides because of the carbon present.

#### NICHROME

The heat-resisting alloys of the nichrome type contain about 60–62% nickel, 12–15% chromium, and 25% iron with, sometimes, 2% manganese. In both the cast and wrought forms the nichromes will have properties



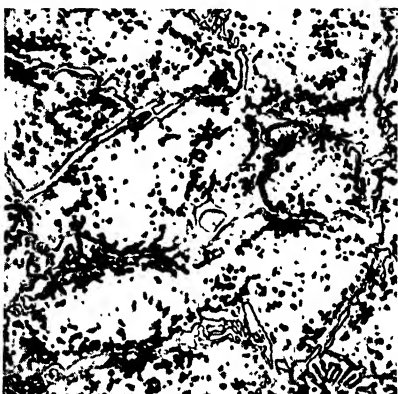
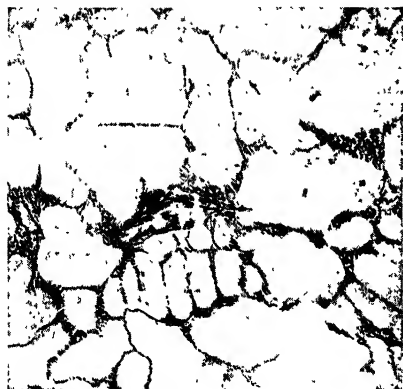


FIGURE 436. (*Upper*) Metallographic structure of a  $\frac{5}{8}$ -in. cast section of a heat-resistant alloy of the 15:35 type. (15.89% Cr — 35.83% Ni — 1.5% Mn — 1.5% Si — 0.57% C — rem. Fe). Etched with aqua regia in glycerine. *Left*,  $\times 100$ . *Right*,  $\times 500$ . (Photomicrographs courtesy The International Nickel Company, Inc.) The structure is austenitic with some coring and contains particles of free carbides, probably complex in nature.

FIGURE 437. (*Lower*) Metallographic structure of a  $\frac{3}{8}$ -in. cast section of a heat-resistant alloy of the Nichrome type (15% Cr — 65% Ni — 0.55% C — rem. Fe). Etched with aqua regia in glycerine.  $\times 500$ . (Photomicrograph courtesy The International Nickel Company, Inc.) The matrix is austenitic with some coring and contains particles of free carbides, probably complex in nature.

midway between the 29:9 and 15:35 alloys, and are used where combinations of high toughness, resistance to oxidation, nitriding and carburizing, and high electrical resistivity are required. Furnace parts, chains and movable belts, carburizing and salt pots, and similar applications are of this type. The alloy can be used satisfactorily up to 2000 F (1100 C).

The commercial alloys *Q Alloy B*, *Calite N2*, *Thermalloy "72," F-1260*, and *Fahrte N-5* are similar to *Nichrome*, differing only slightly in chemical composition. All of them are austenitic under ordinary conditions as illustrated by the metallographic structure of cast *Nichrome* shown in Fig. 437.

The cast materials naturally will show some coring because of the relatively slow rate of solidification. In addition they frequently will run appreciably higher in carbon than the wrought varieties and hence will

have free carbides precipitated, usually at the grain boundaries. The structure of the low-carbon wrought alloys would be similar to those shown in Fig. 534 as well as to those of the other high-nickel wrought alloys.

At room temperature the wrought grades will develop ultimate strengths of 70,000–170,000 psi with yield strengths of 50,000–60,000 psi, elongations of 25% in 2 in., and reductions in area of 50%. The cast grades will have ultimate strengths of about 65,000 psi with 50,000 psi yield strengths. Either form will have a hardness of 180–200 Brinell or Rockwell B90–94.

#### CORROSION-RESISTANT CAST IRONS

The corrosion-resistant cast irons, which are used extensively in chemical plants and oil refineries, are almost all of one of three main types:

1. High-silicon alloys of the *Duriron*<sup>22</sup> or *Durichlor*<sup>22</sup> types.
2. Austenitic nickel alloys of the *Ni-Resist*<sup>22</sup> or *Causal Metal*<sup>22</sup> types.
3. The 15–25% chromium casting alloys of the types which already have been discussed.

#### HIGH-SILICON CAST IRON

Although the high-silicon irons can be made only in the form of castings and although, even in this form, they have a low tensile strength, averaging about 18,000 psi, and are very hard and almost as brittle as glass, they have been used fairly extensively because of their unusual resistance to acid corrosion. These alloys, sold commercially under the names *Duriron* and *Corrosiron*, may vary in composition within the limits:

% C	% SI	% MN	% S	% P
0.2–1.0	13–17	0.25–0.90	0.02–0.05	0.02–0.05

However, the trade-marked alloys are held to the narrow range of 14.35–14.65% silicon because the maximum corrosion resistance seems to correspond to an ordered solid solution containing 14.4% silicon ( $\text{Fe}_3\text{Si}$ ?).

The high-silicon cast irons resist the action of both oxidizing and non-oxidizing acids, particularly the more active ones like nitric, sulfuric, and phosphoric, better than any other metallic materials. This resistance probably is caused by the formation of a protective film of silica on their surface. However, their corrosion resistance is extremely sensitive to the

<sup>22</sup> Registered trade-marks.

amount of silicon present, and consistent results can be secured only by holding this element practically constant.

The usual silicon-iron alloy will not resist corrosion by hydrochloric acid too well. Therefore, a special alloy, sold under the name *Durichlor* and containing approximately 81% Fe-14.5% Si-3.5% Mo-1% Ni, was developed which corrodes at a much lower rate under these conditions. Likewise, the plain alloy does not resist hydrofluoric and the other halide acids, or sulfurous acid too well.

Typical metallographic structures of the alloys Duriron and Durichlor are shown in Fig. 438. The structure of Duriron consists of primary grains of "silico-ferrite," the  $\alpha$  solid solution of silicon and manganese in iron, and an eutecticlike distribution of this constituent with graphite (flake). The molybdenum in Durichlor appears as either  $Fe_3Mo_2$  or  $Fe_3Mo_3C$  in the eutectic constituent. The nickel is dissolved in the silico-ferrite matrix of the alloy and the distribution of flake graphite is essentially the same as in Duriron.

#### AUSTENITIC CAST IRONS

Two varieties of austenitic cast irons have been developed thoroughly, and are being used widely today. The analyses of these will fall in the following ranges; the remainder being essentially iron in each case:

	% SI	% T. C.	% MN	% NI	% CR	% CU
<i>Ni-Resist</i> , regular	1.0-2.5	3.1 (max)	1-1.5	13.5-17.5	1.75-2.50	5.5-7.5
<i>Ni-Resist</i> , copper-free	1.0-2.5	3.1 (max)	1-1.5	18-22	2-4	—

*Causal Metal* has a somewhat similar analysis and properties. The sulfur content of these castings generally is held between 0.04 and 0.12%, and the phosphorus is kept in the range 0.04-0.30%.

These alloys are practically free from growth, i.e., expansion occurring on repeated heating to elevated temperatures, as illustrated in Fig. 440, because they are always austenitic and undergo no phase changes. They also resist scaling very well up to 1500 F (815 C), and they are markedly superior to ordinary gray iron in resisting the action of many corrosive agents including several acids, alkalies, salts, and corrosive gases. A typical microstructure is shown in Fig. 439. A few residual carbides can be seen in the austenitic matrix in addition to the flake graphite.

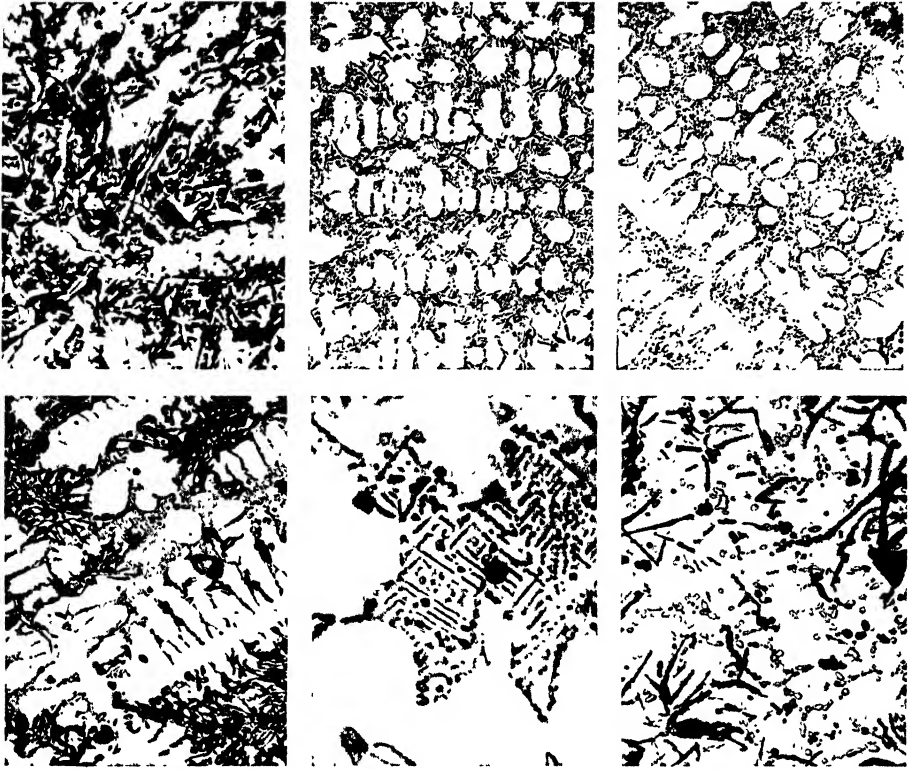


FIGURE 438. Metallographic structures of the alloys Duriron (*upper series*) and Durichlor (*lower series*). Etched with mixed acids in glycerol. Duriron consists of graphite in a dendritic matrix of "silico-ferrite," i.e., iron containing silicon and manganese in solid solution. The graphite may vary in size from the coarse form shown in the left picture,  $\times 100$ , to the fine form shown in the right picture,  $\times 100$ . The center picture,  $\times 100$ , shows the intermediate form which is most desirable from the viewpoint of mechanical properties. Intermediate structures which are a combination of the coarse and fine forms also may be found in the commercial product. Commercial castings are annealed 4 hr at 1660 F (905 C) to improve their strength. This does not change the microstructure, however. The effect of structure on the corrosion resistance and mechanical properties is small. The structure of Durichlor consists of graphite in a dendritic matrix of "silico-ferrite" and its eutectic with  $\text{Fe}_3\text{Mo}_2$  or iron-molybdenum carbide ( $\text{Fe}_3\text{Mo}_3\text{C}$ ). This is seen in the as-cast structure,  $\times 100$  (left) and  $\times 500$  (center). After annealing at 1660 F (905 C) for 24 hr, in accordance with commercial practice, the strength has been increased about 25% and the molybdenum constituent has been coalesced as shown,  $\times 100$ , at the right. (Courtesy The Duriron Company, Inc.)

The chromium is added to increase the hardness and strength to values comparable with those of ordinary gray iron. Without chromium the Brinell hardness is about 100, and it increases roughly about 20 points with each 1% chromium added. A limit of 2–3% chromium, however, is main-

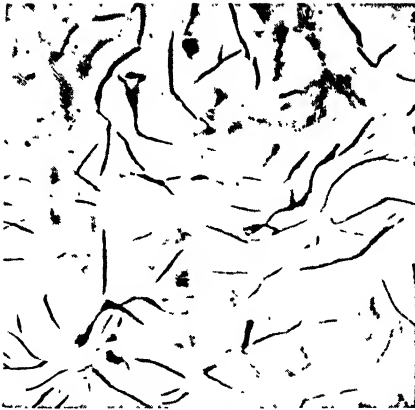


FIGURE 439. (Left) Metallographic structure of Ni-Resist austenitic cast iron (2% Si - 2.8% T.C. - 1% Mn - 14% Ni - 2% Cr - 6% Cu - rem. Fe). Etched with 5% picral.  $\times 100$ . (Photomicrograph courtesy The International Nickel Company, Inc.) The matrix is austenitic, containing graphite flakes and small residues of the eutectic, alloyed ledeburite, between iron-chromium carbides and austenite.

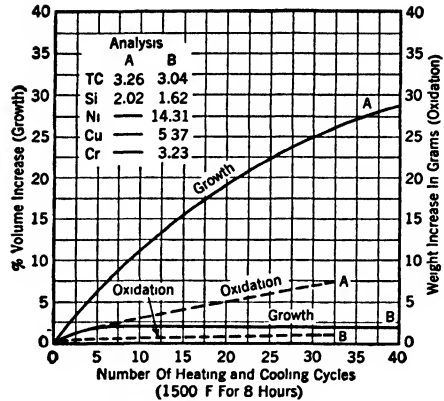


FIGURE 440. (Right) Typical curves showing oxidation and growth of a plain cast iron (A) and an austenitic cast iron (B) at 1500 F (815 C). (Courtesy The International Nickel Company, Inc.)

tained as a rule in order to retain machinability, which is apt to be somewhat poor anyway because of the greater toughness of the austenitic matrix as compared with the usual pearlitic matrix of ordinary gray iron. By varying the carbon and silicon contents, mechanical properties can be secured in the range:

Arbitration bar transverse strength: 2000-2800 lb

Arbitration bar transverse deflection: 0.3-0.9 in.

Tensile strength ( $1\frac{1}{4}$  in. section): 25,000-40,000 psi

The alloys also have fair impact values.

Because these alloys corrode, i.e., rust, by a uniformly distributed surface oxidation, they cannot be used where this would be deleterious, as in the manufacture of high-purity sulfuric acid for example. However, they are used in the chemical industries and oil-refinery service for such purposes as mixing kettles, valve bodies and fittings, filter grids, casings, impellers and other parts in pumps, liners and valve seats in compressors, heat-exchanger shells, condenser sections and headers, bubble caps, and similar applications. They also are used, to some extent, in parts for electric furnaces where their electrical resistance, and heat and corrosion resistance serve to advantage. The copper-free alloys are used chiefly where resistance to alkaline agents is the main consideration, and the advantages of the higher nickel content are desirable.

## HEAT-RESISTING CAST IRONS

For the cast irons, heat resistance, which becomes important when castings are used above 800 F (425 C) in air or superheated steam, implies a resistance to growth, as well as the usual meaning of retention of mechanical properties and resistance to scaling. *Growth* in cast irons is attributable both to graphitization and to an infiltration of gases. In severe cases, it may lead to increases of as much as 50% in volume, leaving the casting weak and brittle.<sup>23</sup> Growth will occur whenever castings are reheated repeatedly to temperatures above 800 F (425 C), and the amount of growth for a given iron is proportional to the heating temperature and the number of heatings, as illustrated in Fig. 440 for both a plain and an alloy cast iron at 1500 F (815 C).

For resisting growth, low-silicon contents to limit the graphitizing tendency and the addition of some chromium to stabilize the carbides are generally desirable.<sup>24</sup> A phosphorus content somewhat higher than normal is frequently beneficial also. Some typical analyses for specific applications are shown in Table XXIII.

TABLE XXIII SOME ANALYSES TYPICAL OF HEAT-RESISTING CAST IRONS

APPLICATION	% SI	% T. C.	% MN	% NI	% CR
Diesel engine cylinder heads	1.2	3.2	0.6	1.5	0.3
Grate bars	1.5	3.4	0.7	1.5	0.6
Cracking still tube sheets, up to 1200 F (650 C)	1.2	3.0	0.6	1.5	0.7
Stoker links, up to 1400 F (750 C)	2.0	3.2	0.6	—	1.0
Exhaust manifolds	2.0	3.4	0.6	—	0.4

In these alloys the graphitic carbon will generally range 2.2–2.8% with the combined carbon 0.6–0.8%. The sulfur seldom if ever exceeds 0.14%, and the phosphorus is usually held at 0.40% maximum. Both of these elements, however, may run appreciably lower. Molybdenum, in the range 0.35–1.0%, sometimes is added to assist the heat resistance.

Ni-Resist, Causal Metal and similar austenitic alloys also are used sometimes for applications requiring resistance to temperatures up to 1500 F

<sup>23</sup> See, for a good discussion of this, *Symposium on Cast Iron*, Joint A.F.A.–A.S.T.M. Publication, 1933; A. L. Norbury and E. Morgan, *Journ. Iron & Steel Inst.*, London, 123, 1931, 428.

<sup>24</sup> The effect of various elements is discussed by R. R. Kennedy and G. J. Oswald, *Trans. A.F.A.*, 34, 1926, 871–880.

(815 C), such as for exhaust manifolds in automobile, truck, and bus engines. For still higher temperatures, such as would be encountered in the liner plates used to receive hot clinker in cement plants, chain conveyer links used in heat-treating furnaces, and certain types of stoker links, recourse must be made to the high-chromium stainless cast irons of the types that already have been mentioned.

#### NICKEL-BASE ALLOYS

Where the necessity for the combination of good engineering properties with a resistance to the severer forms of chemical corrosion is great enough to offset a comparatively high cost, the nickel-base alloys must be seriously considered. These alloys have, in addition to their corrosion resistance, good strengths, good thermal and electrical conductivities, a high modulus of elasticity, and are quite workable.

The oxidation resistance of most nickel-base alloys is good and the metal itself may be used almost indefinitely up to temperatures of 1500–1600 F (815–870 C) without serious deterioration, provided the conditions are always oxidizing. Under elevated temperature conditions in which the atmosphere is alternately oxidizing and reducing, however, an accelerated type of attack is likely to take place on nickel. Although the oxide formed by a consistently oxidizing gas is protective as long as the oxide layer does not scale off, it is not stable against a reducing gas. Consequently, under conditions which alternate between oxidizing and reducing the oxide is alternately formed and reduced, and the attack on the metal is accelerated greatly thereby. In many nickel alloys, in addition, there seems to be a preferential oxidation at the grain boundaries. Under oxidizing conditions alone this is probably beneficial as the surface oxide formed is thereby bound more tightly to the underlying metal. Under alternating oxidizing–reducing conditions, however, the reduction of this grain boundary oxide probably assists materially in promoting grain boundary disintegration. This is particularly important because of the frequency with which alternating oxidizing–reducing conditions appear in commercial applications.

For purposes of discussion, the nickel-base alloys may be classified most easily into five groups.

1. *Commercial Nickels*
2. *Monels*<sup>25</sup>
3. *Inconel*<sup>25</sup>
4. *Hastelloys*<sup>25</sup>
5. *Illium*<sup>25</sup>

<sup>25</sup> Registered trade-marks.

## COMMERCIAL NICKELS

There are five commercial nickels having the nominal percentage compositions listed in Table XXIV. The first four are wrought alloys.

TABLE XXIV NOMINAL COMPOSITIONS OF THE COMMERCIAL NICKELS

	% NI*	% MN	% C	% CU	% FE	% SI
<i>A Nickel</i> §	99.4	0.2	0.1	0.1	0.15	0.05
<i>L (Carbon-Free) Nickel</i> §	99.4	0.2	0.0‡	0.1	0.15	0.05
<i>D Nickel</i> §	95.2	4.5	0.1	0.05	0.15	0.05
<i>Z Nickel</i> †§	95–98.5% Ni, 0.15–0.5% C, 0.2–0.45% Mg, 0.1–1.0% Ti					
<i>Cast Nickel</i>	96.7	0.5	0.5	0.3	0.50	1.50

\* Including cobalt. ‡ Max § Registered trade-marks.

† Also contains some residual manganese left after deoxidation and desulfurization. W. J. Kroll, *Metals and Alloys*, 20, 1944, 1604, gives, for an analysis of this alloy: 97.90% Ni–0.33% Ti–0.85% Co–0.17% Mn–0.13% Si–0.26% C–0.30% Mg.

All of the wrought varieties fall within the limits of A.S.T.M. Tentative Standards B160-T (Rods and Bars), B161-T (Pipe and Tubing), B162-T (Plate, Sheet, Strip), and B163-T (Condenser Tubes and Ferrule Stock).

All forms of nickel are strongly magnetic at room temperature. Nickel and “L” Nickel retain their magnetism to 680 F (360 C), but “D” Nickel becomes nonmagnetic at 570 F (300 C) and “Z” Nickel at 280 F (140 C).

## “A” NICKEL

The general relationship between tensile properties and Rockwell hardness for nickel<sup>26</sup> is indicated in Fig. 441 for several different treatments. In all except the fully work-hardened condition the combination of strength and ductility is excellent. The retention of these properties, as indicated (Fig. 442) by short-time tests at elevated temperatures, is also very good. From these data nickel would be expected to be an extremely tough metal. This is borne out by impact tests which show also that the room-temperature toughness is retained to temperatures as low as –310 F (–190 C). Unfortunately, this toughness also tends to make the metal very difficult to machine, so low cutting speeds, light feeds, and high-speed steel tools

<sup>26</sup> This is general usage for “A” Nickel.



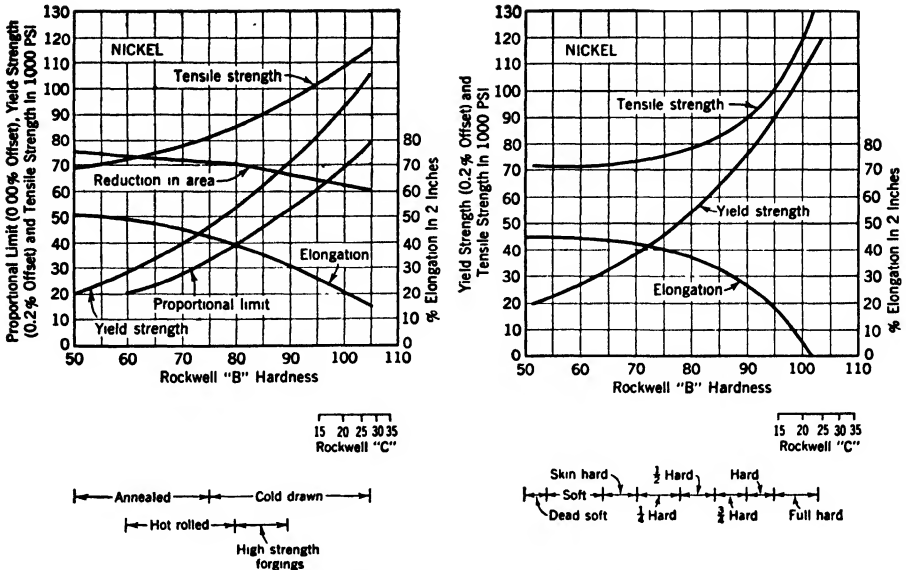


FIGURE 441. Relationships between average tensile properties of nickel and Rockwell hardness.

- a. (Left) Hot-rolled, forged, and cold-drawn rods.
- b. (Right) Cold-rolled sheet and strip.

(From *Nickel and Nickel Alloys*, courtesy The International Nickel Company, Inc.)

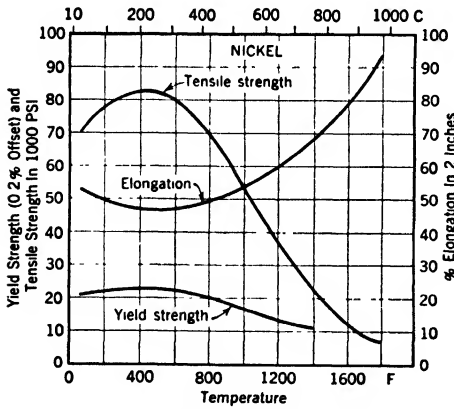


FIGURE 442. Tensile properties of hot-rolled nickel at elevated temperatures. (From *Nickel and Nickel Alloys*, courtesy The International Nickel Company, Inc.)

must be used as considerable heat will be generated during machining. High-sulfur oils assist materially.

The resistance of nickel to many corroding agents is satisfactory. In general, oxidizing conditions attack it more severely than reducing conditions although sometimes even the rate of attack under oxidizing conditions will be less than expected because of the formation of a tightly adherent oxide coating or of a passivated film. Nickel is very resistant to most atmospheric and fresh- and salt-water corrosion,

and to many neutral and alkaline salt solutions, such as chlorides, carbonates, sulfates, nitrates, and acetates. Its resistance to acid salt solutions is somewhat poorer; and oxidizing salts, both acid and alkaline, and oxidizing acids generally, attack it readily. Its resistance to organic acids

may vary, but generally is fair unless the acids are very hot and saturated with air. The action of alkalis, particularly caustic soda, is slight, and nickel is used widely wherever resistance to this material is valuable. Moist gases, such as chlorine and the other halogens, nitrous oxide, sulfur dioxide, and ammonia, tend to corrode nickel rapidly.

Nickel hot-works readily, especially in the range 1600–2300 F (850–1250 C), although it can be hot-worked, with somewhat more difficulty than steel, as low as 1200 F (650 C). The metal also can be cold-worked readily if allowance is made for its fairly high elastic limit, which necessitates the use of somewhat greater power than for mild steel. After cold-work, it may be box annealed in 2–6 hr at 1350–1450 F (730–790 C), or open annealed in 2–5 min at 1600–1750 F (870–950 C). Full softening, however, will require times about 50% longer. Lower temperatures for annealing may be used, but they are somewhat uncertain because of possible variations in the amount of cold-work and the carbon content. Quenching, in water containing about 2% of denatured alcohol, following annealing tends to prevent oxidation. In annealing nickel or its alloys, sulfur-bearing and highly oxidizing furnace gases should be avoided as far as possible.

The metallographic structure of worked and annealed nickel is a typical fine-grained, twinned structure similar to that shown in Figs. 178 and 443. The cast form will have a larger grain size and, because of its somewhat greater percentage of impurities and slow rate of solidification, usually will exhibit some coring.

#### “L” NICKEL (CARBON-FREE)

The chief advantage of “L” nickel is its ability to withstand oxidizing furnace atmospheres at temperatures up to 2000 F (1100 C). It is appreciably softer than nickel, and does not work-harden so rapidly. Its elastic and strength properties are also somewhat lower than those of the regular variety, and its ductility is somewhat higher. Carbon-free nickel is used



FIGURE 443. Metallographic structure of a worked and annealed nickel having a fairly coarse grain size. Etched with Marbles reagent (4 g  $\text{CuSO}_4$ , 20 ml  $\text{HCl}$ , 20 ml  $\text{H}_2\text{O}$ ) to produce contrast.  $\times 100$ . The appearance of this structure when etched with a flat solution can be seen in Fig. 178. (Photomicrograph by L. Litchfield.)

chiefly for articles which are difficult to fabricate, for laboratory equipment required to withstand high temperatures, for resistance to fused caustic, and for containers for molten nitrates. Metallographically, "L" nickel would be essentially the same as nickel.

#### "D" NICKEL

The addition of about 4.5% manganese to nickel increases its resistance to atmospheric attack at elevated temperatures, especially under sulfidizing conditions. Under sulfur-free oxidizing conditions, however, it even may be somewhat inferior to nickel. The alloy "D" nickel is also highly resistant to conditions of electrical sparking, and hence is used for spark-plug electrodes, ignition tubes, and similar applications where this factor is of importance. Its strength both at normal and elevated temperatures is somewhat greater than that of nickel.

Metallographically, it would be indistinguishable from the ordinary variety because the manganese is in solid solution.

#### "Z" NICKEL

The corrosion resistance of "Z" nickel is about the same as that of nickel. It work-hardens more rapidly than nickel, however, and, in addition, can be hardened by heat-treatment. Since this hardening results from precipitation and is carried out below the strain annealing temperature, its effects can be superimposed on those of the cold-work thus giving more marked hardening than would be possible otherwise.

In Fig. 444 are plotted short-time tensile data at elevated temperatures for both soft and heat-treated "Z" nickel.

The alloy first must be full annealed, i.e., softened and solution treated, by quenching from 1950–2000 F (1070–1090 C) in order to prepare it for either cold-work or the precipitation heat-treatment. The preferred precipitation heat-treatment is 16–24 hr at 930 F (500 C) for the soft alloy, or 8–16 hr at 880–920 F (475–490 C) for the cold-worked material.

The metallographic structures in the quenched, slowly cooled, and precipitation-hardened conditions are illustrated in Fig. 445. The precipitate in the slowly cooled alloy is probably a carbide, possibly of titanium.

The alloy "Z" nickel has a higher elastic limit than nickel and must be forged above 1800 F (1000 C). In addition, it work-hardens very rapidly, and hence must be annealed after reductions of about 50% maximum. It may be machined in the soft condition, but only if speeds somewhat lower than those for nickel are used.

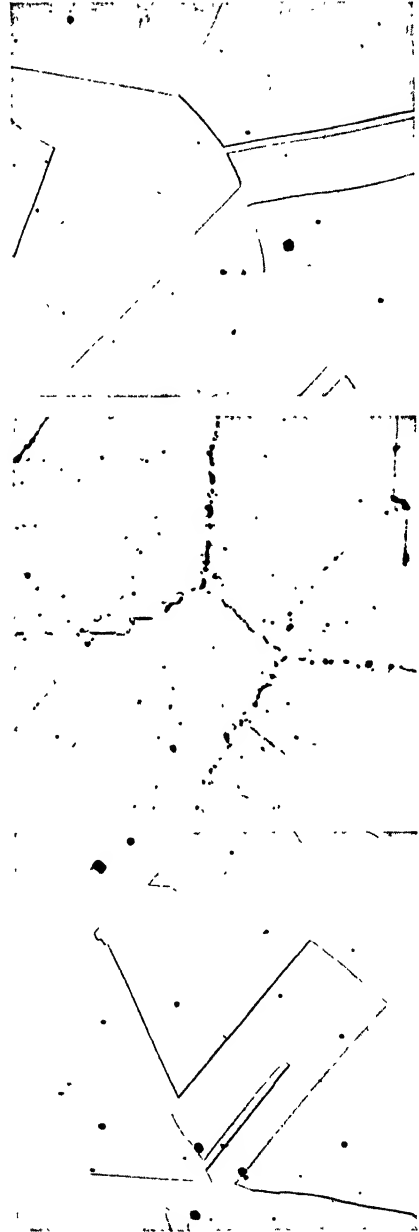
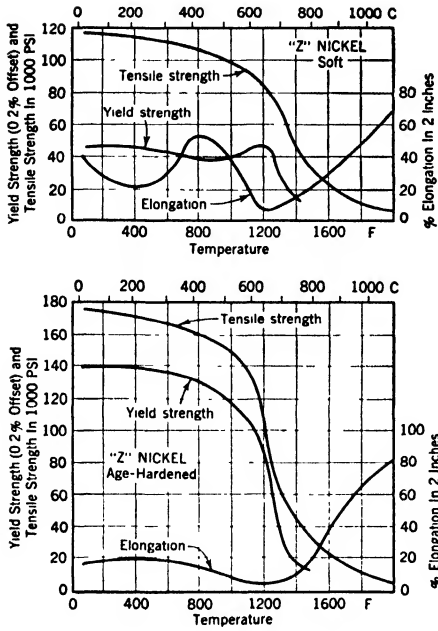


FIGURE 444. (Left) Short-time tensile properties of "Z" nickel at elevated temperatures. Upper, soft. Lower, precipitation-hardened. (From *Nickel and Nickel Alloys*, courtesy The International Nickel Company, Inc.)

FIGURE 445. (Right) Metallographic structures of "Z" nickel. Etched with nitric and acetic acids.  $\times 250$ .

- a. (Top) As quenched from 1975 F (1080 C).
  - b. (Middle) Slowly cooled from 1975 F (1080 C).
  - c. (Bottom) Quenched and aged to maximum hardness.
- (Photomicrographs courtesy The International Nickel Company, Inc.)

THE MONEL ALLOYS

The original Monel metal composition was reduced metallurgically from a natural mixture of nickel and copper ores as previously discussed in Chap. VII. The alloy was found to have very valuable corrosion-resist-

ing properties, and was marketed in its natural composition instead of separating the nickel and copper further, a separation which, at the time, was extremely difficult. Today, monels of the five different nominal compositions shown in Table XXV are made by The International Nickel Company, the largest producer.

TABLE XXV NOMINAL CHEMICAL COMPOSITIONS OF THE COMMON MONEL ALLOYS

	% NI	% CU	% FE	% AL	% SI	% MN	% C
<i>Wrought Monel</i>	67	30	1.4	—	0.1	1.0	0.15
<i>Wrought K Monel*</i>	66	29	0.9	2.75	0.5	0.4	0.15
<i>Cast Monel</i>	67	29	1.5	—	1.25	0.9	0.3
<i>Cast H Monel*</i>	65	29.5	1.5	—	3.0	0.9	0.1
<i>Cast S Monel*</i>	63	30	2.0	—	4.0	0.9	0.1

\* Registered trade-marks.

A free-machining grade *R Monel*,<sup>27</sup> running somewhat higher in sulfur than the regular wrought variety, is also available commercially. Both wrought Monel and "R" Monel fall within the limits of A.S.T.M. Tentative Standards B127-T (Plate, Sheet, Strip), B163-T (Condenser Tubes and Ferrule Stock), B164-T (Rods and Bars), and B165-T (Tubing).

Because of the high content of alloying elements, wrought Monel becomes nonmagnetic at 110–140 F (45–60 C), cast Monel at 95 F (35 C) and the other varieties well below room temperature.

#### WROUGHT MONEL METAL

The general relationship at room temperature between properties and Rockwell hardness for wrought Monel metal sheet, strip, and rod of various tempers is indicated in Fig. 446. As judged by short-time tensile tests, the alloy retains its properties reasonably well at elevated temperatures up to about 575 F (300 C) (Fig. 447a), and the creep strength, as determined in long-time tests, is also satisfactory. Below room temperatures (Fig. 447b) the yield strength, tensile strength, and hardness all increase; but the fact that the ductility and impact values remain essentially unchanged shows that this increase is accompanied by no increase in brittleness.

The comparatively high elastic limit and low brittleness of the alloy tends to lower its machinability, and necessitates the use of cutting speeds

<sup>27</sup> Registered trade-mark.

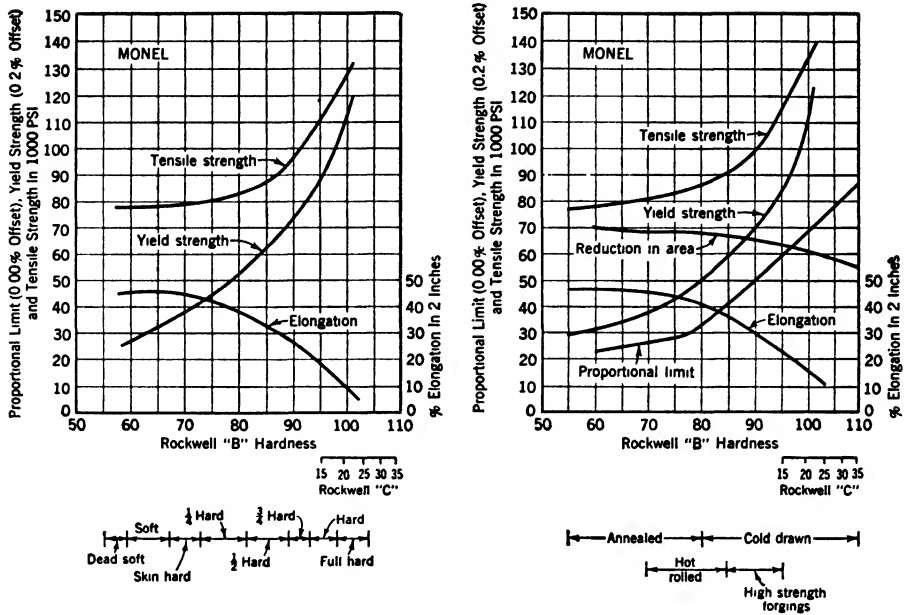


FIGURE 446. Relationships between average tensile properties of Monel metal and Rockwell hardness. *a.* (Left) Sheet and strip. *b.* (Right) Hot-rolled and cold-drawn rod. (From *Nickel and Nickel Alloys*, courtesy The International Nickel Company, Inc.)

that are somewhat slower and feeds that are somewhat lighter than those used for mild steel. The use of a sulfurized oil as a lubricant is beneficial, but when higher cutting speeds must be maintained, the use of "R" Monel is recommended. This modification has a better machinability, and is only slightly inferior in strength and other properties to the ordinary variety.

Monel resists most acids fairly well, unless they are either air saturated, hot, or inherently oxidizing. Its resistance to most salt solutions, unless they are acid or strongly oxidizing, is also very good. The attack of most alkaline solutions is slight, unless ammonia is present. In addition, most waters and atmospheric conditions have but little effect unless the corroding conditions are particularly harmful to copper, in which case a typical copper corrosion product may form on the surface of the alloy. At elevated temperatures an adherent oxide scale forms which permits the alloy to be used up to about 1000 F (540 C), provided sulfur compounds are not present. Monel metal is apt to be seriously attacked by highly oxidizing acids, ferric, stannic, and mercuric salts, sulfur-bearing gases, especially above about 700 F (370 C), and molten metals.

Wrought Monel is readily hot-worked between 1600 and 2150 F (870 and 1170 C). However, in the range 1200–1600 F (650–850 C), the alloy has reduced hot ductility and a comparatively high elastic strength, so

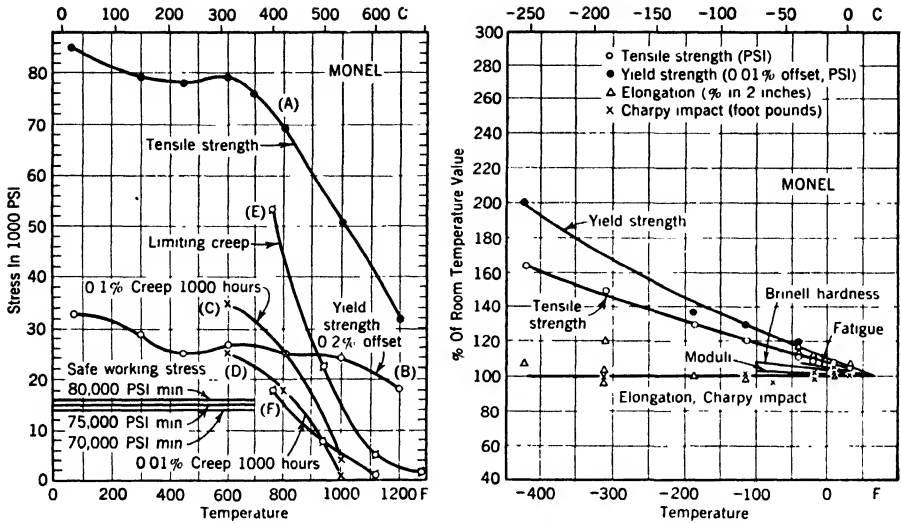


FIGURE 447. Variation of mechanical properties of Monel metal with temperature. *a. (Left)* Elevated temperature short-time properties and creep characteristics. Curves *A* and *B* tensile and yield strengths at elevated temperatures on 1-in. diameter hot-rolled and annealed bar. Tests made in the Research Laboratories of The International Nickel Company. Curves *C* and *D* from creep tests made by Clark and White at the University of Michigan on hot-rolled and annealed bars. Curve *E* limiting creep on hot-rolled bar. (Tapsell and Bradley.) Tapsell defines limiting creep as "the load per unit of original area which will just not break the bar when allowed to remain on the material for a very long time." Curve *F* safe working stress suggested by Tapsell as one third the limiting creep.

*b. (Right)* Percentage change in mechanical properties as temperature drops to that of liquid air.

(Courtesy The International Nickel Company, Inc.)

hot-working should be avoided. Because of their harmful atmospheric effects at these temperatures, sulfur-bearing fuels should be avoided, and the alloy should not be "soaked" but should be placed in a hot furnace, and worked rapidly as soon as the desired temperature has been reached.

Except for its higher elastic limit, which necessitates the use of somewhat more power, Monel works cold in a manner similar to mild steel. For best results, die surfaces should be highly polished, and heavy lubricants used. After cold-working, it may be annealed at temperatures slightly higher than those already recommended for nickel. During annealing, a reducing atmosphere is desirable, and an alcohol quenching bath, in the proportion of 1 gal of alcohol to 50 gal of water, is recommended for reducing the oxide flash after annealing.

Metallographically, the alloy is practically indistinguishable from commercial nickel as shown by comparing Figs. 177 and 178, the hot-worked or cold-worked and annealed material having a typical twinned equiaxed

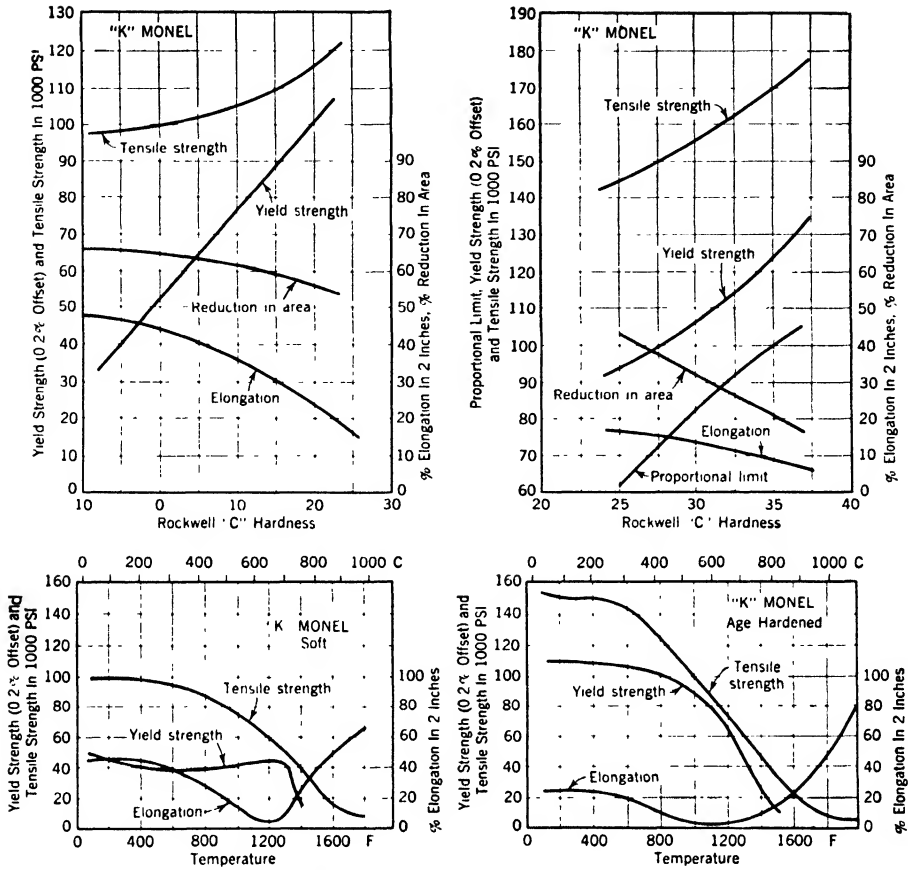


FIGURE 448. Relationships between average tensile properties of "K" Monel and Rockwell C hardness or test temperature.  
 a. (Upper left) Hot-rolled and cold-drawn rod, tested at room temperature.  
 b. (Upper right) Cold-drawn rod, heat-treated (properties for both hot-rolled and forged rod, heat-treated, are roughly similar to these), tested at room temperature.  
 c. (Lower left) Soft (hot-rolled and quenched), tested at elevated temperatures.  
 d. (Lower right) Hot-rolled and age-hardened, tested at elevated temperatures.  
 (From *Nickel and Nickel Alloys*, courtesy The International Nickel Company, Inc.)

structure and the cast alloy showing distinct coring in either alloy. The free-machining variety, "R" Monel, also shows inclusions of nickel sulfide.

"K" MONEL

Typical relationships between tensile properties and Rockwell hardness for "K" Monel rods in the hot-rolled, cold-drawn, and heat-treated conditions are shown in Fig. 448. Even in the hot-worked condition this alloy



possesses excellent strength properties, and in the fully heat-treated condition its combination of strength and ductility is quite remarkable.<sup>28</sup> Cold-drawn wire may be heat-treated to a tensile strength of 170,000–200,000 psi giving properties which are useful for springs in large sizes that cannot be readily fabricated by cold-working. The retention of spring properties at elevated temperatures, as determined by relaxation tests, is excellent.

The alloy “K” Monel is nonmagnetic at room temperature and remains so down to  $-150\text{ F}$  ( $-100\text{ C}$ ).

The corrosion resistance of “K” Monel is similar to that of Monel.

The best forging range is  $1700\text{--}2150\text{ F}$  ( $925\text{--}1175\text{ C}$ ). After heating, the alloy should be quenched from a temperature of  $1450\text{ F}$  ( $790\text{ C}$ ), or above, in water containing about 2% of alcohol. The alloy then will be soft enough for cold-working.

The cold-working characteristics are similar to those of Monel, but somewhat more power will be required because of its greater hardness and its greater rate of work-hardening. However, the high ductility of “K” Monel is a decided advantage. Machinability is fair up to hardnesses of about 275 Brinell; but best results are secured if tools of high-speed steel are employed. A free-machining grade, *KR Monel*, containing more carbon than the regular variety, is available commercially.

The recommended heat-treatment for softening is 2–5 min at  $1600\text{ F}$  ( $870\text{ C}$ ) or  $\frac{1}{2}$ –2 min at  $1800\text{ F}$  ( $980\text{ C}$ ), followed by quenching. Sections heavier than about 2 in. thick are likely to develop cracks unless quenched. However, if sufficiently long times are used, either partial or complete softening can be secured by quenching from temperatures above  $1100\text{ F}$  ( $600\text{ C}$ ). Sections under 2 in. even may be partially softened by air cooling. If the quenched alloy is to be heat-treated for hardness, this may be done by a single heat-treatment for 10–16 hr at  $1080\text{--}1100\text{ F}$  ( $585\text{--}595\text{ C}$ ), followed by slow cooling in the furnace. If the alloy has been previously cold-worked the initial temper of the material must be known if the heat-treatment is to be carried out satisfactorily as both the temperature and time will vary with this factor. When “K” Monel has been heat-treated to produce maximum hardness it will not show any appreciable change of properties if again heated to or held at any temperature below that at which the original precipitation heat-treatment was carried out.

The applications of “K” Monel invariably involve an excellent corrosion resistance and a higher hardness or greater strength than can be secured with the standard Monel alloy. Shafts, sleeves, and liners, particularly in pumping equipment for marine, petroleum, or chemical industry use, seats and needles of fuel injection valves for Diesel engines, valves

<sup>28</sup> See also W. A. Mudge and P. D. Merica, *Trans. A.I.M.E.*, **117**, 1935, 265–276.

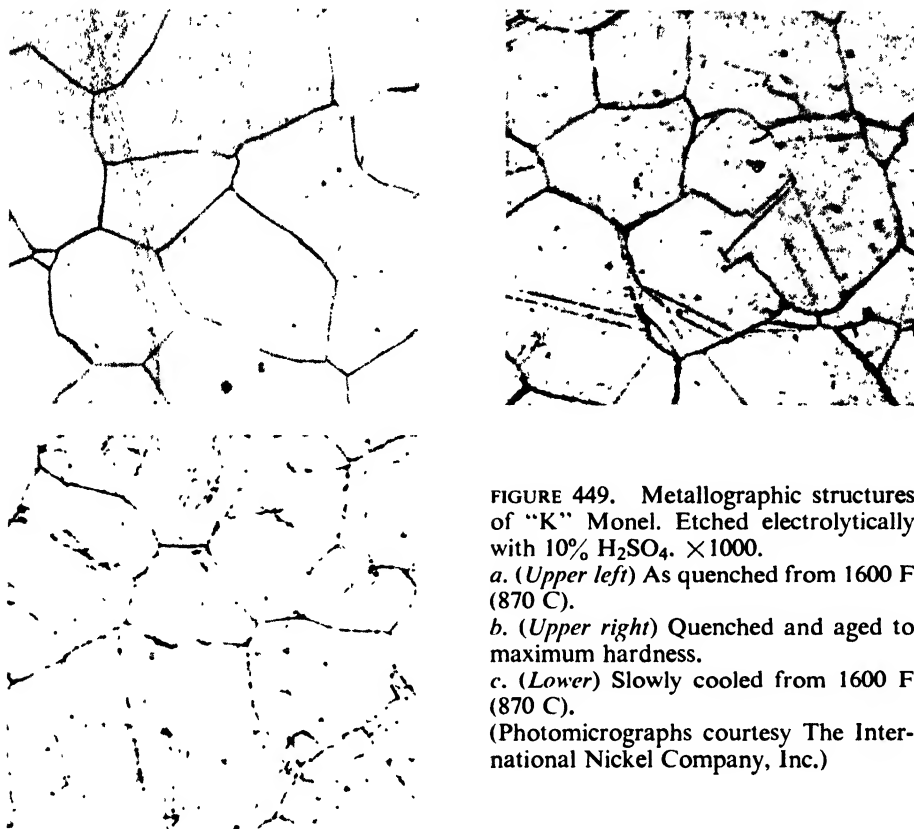


FIGURE 449. Metallographic structures of "K" Monel. Etched electrolytically with 10%  $H_2SO_4$ .  $\times 1000$ .

a. (Upper left) As quenched from 1600 F (870 C).

b. (Upper right) Quenched and aged to maximum hardness.

c. (Lower) Slowly cooled from 1600 F (870 C).

(Photomicrographs courtesy The International Nickel Company, Inc.)

subjected to corrosion by alkaline waters, airplane instruments, because of the alloy's nonmagnetic nature and excellent mechanical properties even at low temperatures, and applications in which its excellent spring properties and wear and oxidation resistance are valuable, such as in some forms of electrical equipment, are common places where this alloy is used.

The metallographic structures in Fig. 449 for the quenched, precipitation-hardened, and slow-cooled conditions are typical. The precipitate, which is believed to be a secondary solid solution composed of  $NiAl$  and  $Cu_3Al$  in varying proportions, is very fine and impossible to resolve metallographically; it is visible with the electron microscope, however.

#### CAST MONEL

The three cast Monel analyses vary chiefly in their silicon content. Silicon makes the alloy stronger and harder, and also increases its resistance to galling. Both sand and centrifugal castings are made.

## INCONEL

Inconel is a corrosion-resisting nickel-base alloy to which chromium has been added to increase the resistance to sulfur compounds and to oxidizing conditions at elevated temperatures and in corrosive solutions. The nominal compositions of the wrought and cast forms are:

	% NI	% CU	% CR	% FE	% MN	% SI	% C	% S
<i>Wrought Inconel</i>	78.50	0.20	14.0	6.5	0.25	0.25	0.08	0.015
<i>Cast Inconel</i>	77.75	0.25	13.5	6.0	0.25	2.00	0.25	0.010

The wrought form is covered by A.S.T.M. Tentative Standards B163-T (Condenser Tubing and Ferrule Stock), B166-T (Rods and Bars), B167-T (Pipe and Tubing), and B168-T (Plate, Sheet, Strip).

The relationships between the strength properties and the hardness of Inconel in the form of sheet, strip, and rods are shown in Fig. 450. These properties are retained well at elevated temperatures up to about 950 F (500 C), as indicated by the short-time, high-temperature tensile test data in Fig. 451. Inconel has good creep strengths at temperatures up to 2000 F (1100 C).

Because of its hardness, Inconel is machinable with some difficulty, and considerable heat is generated. For this reason, high-speed steel tools should be used and kept sharp. Low speeds are desirable, approximately two thirds of those used for Monel, and sulfur-base oils give best results as lubricants.

Inconel was developed originally to resist corrosion by foods, especially dairy products and fruit juices. However, it also resists a great variety of other corroding conditions. The comparatively high chromium content makes it resistant to oxidizing conditions; and the high nickel content imparts an excellent resistance to both reducing and alkaline conditions. In strongly oxidizing solutions, the alloys tend to become passive. The resistance to progressive oxidation at temperatures up to 2000 F (1100 C) is excellent; and even in oxidizing sulfur-bearing atmospheres Inconel can be used safely to about 1500 F (820 C).

Inconel can be forged readily between 1850 and 2300 F (1000–1250 C). However, because of reduced ductility the alloy should not be worked between 1200 and 1600 F (650–870 C). Work done below 1200 F (650 C) is classed as cold-work. After cold-working, internal stresses may be re-

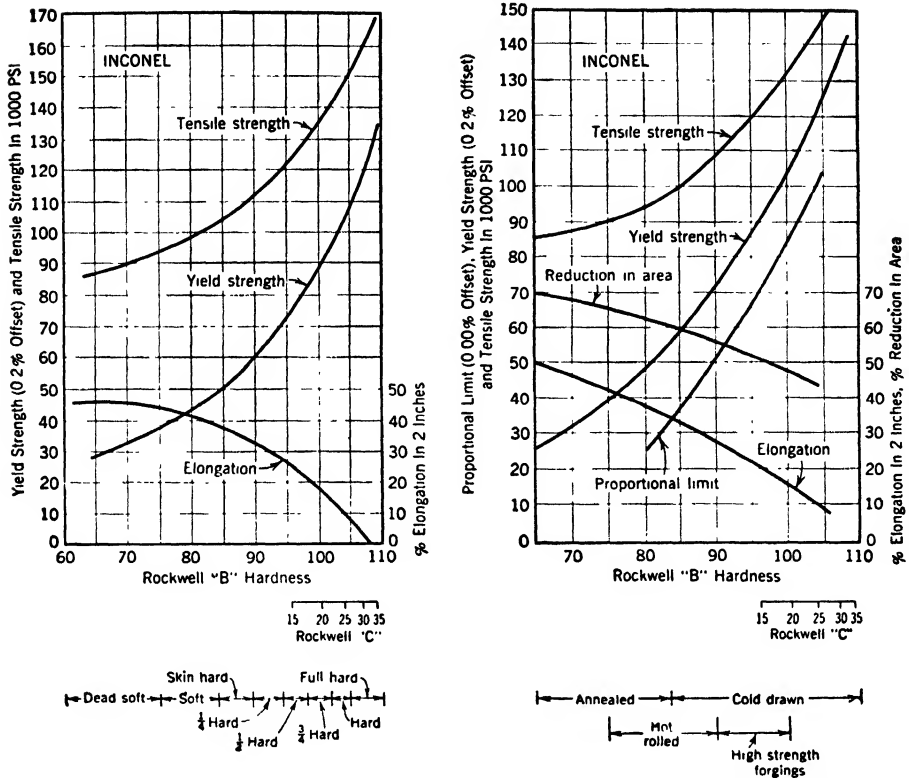


FIGURE 450. Relationships between average tensile properties of Inconel and Rockwell hardness.

a. (Left) Sheet and strip.

b. (Right) Hot-rolled and cold-drawn rod.

(From *Nickel and Nickel Alloys*, courtesy The International Nickel Company, Inc.)

lied by heating between 1000 and 1400 F (540–760 C). Annealing 1½ hr at the latter temperature will relieve stresses almost entirely with only slight softening. Softening by annealing begins at about 1600 F (870 C), and is reasonably complete in about 15 min at 1800 F (980 C). Above this temperature, grain coarsening is apt to occur unless the heating times are very short. The rate of cooling following any heat-treatment is unimportant.

The microstructure of rolled and annealed Inconel, shown in Fig. 452, is typical of a twinned nickel-rich solid solution. The chromium and iron, being both in solid solution in the nickel, are not visible in the structure.

Inconel alloys, which are made age-hardenable by the use of certain additional elements, are in process of development and may be expected to be available commercially within the next few years. When perfected,

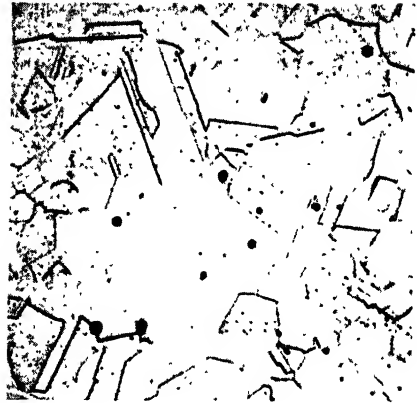
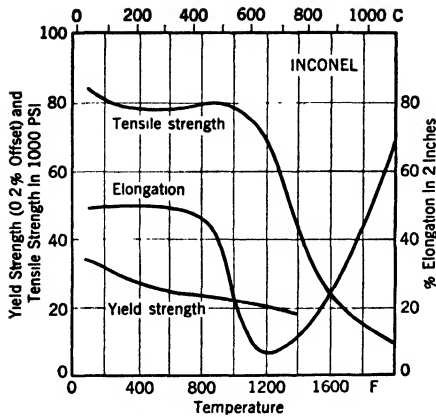


FIGURE 451. Short-time tensile properties of hot-rolled Inconel at elevated temperatures. (From *Nickel and Nickel Alloys*, courtesy The International Nickel Company, Inc.)

FIGURE 452. Metallographic structure of rolled and annealed Inconel (14% Cr — 6.5% Fe — rem. Ni). Etched with HF and HNO<sub>3</sub>.  $\times 100$ . (Photomicrograph by L. Litchfield.)

these alloys will be useful in high temperature engines, such as gas turbines, which operate at temperatures up to 1500 F (820 C).

#### HASTELLOY

The various grades of Hastelloy,<sup>29</sup> the compositions of which are given in Table XXVI, were developed by the Haynes Stellite Company primarily

TABLE XXVI CHEMICAL COMPOSITIONS OF THE VARIOUS GRADES OF HASTELLOY

	% NI	% CU	% FE	% CR	% MO	% AL	% SI	% MN	% W
<i>Hastelloy A</i>	57	—	20	—	20	—	1	2	—
<i>Hastelloy B</i>	62	—	6	—	30	—	1	1	—
<i>Hastelloy C</i>	55	—	6	15	17	—	1	1	5
<i>Hastelloy D</i>	85	3	—	—	—	1	10	1	—

to resist corrosion by mineral acids. Because of their comparatively high cost, it is this characteristic which largely determines their use.

Hastelloy A, B, and C can be secured in both the cast and wrought

<sup>29</sup> Registered trade-mark.

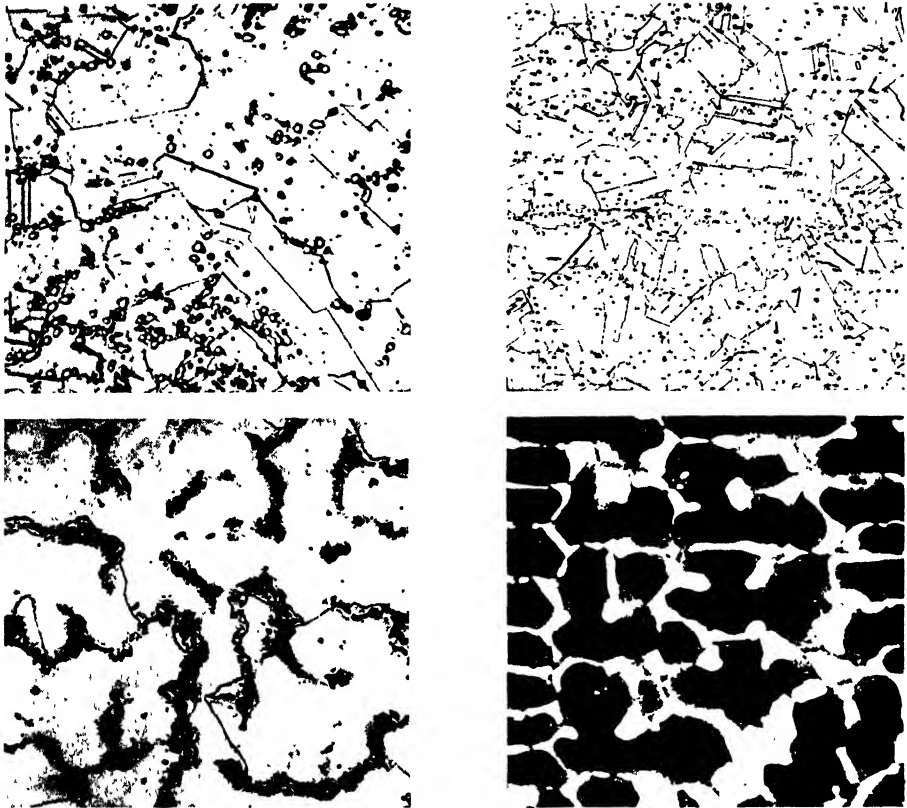


FIGURE 453. Metallographic structures typical of the various grades of Hastelloy.  $\times 250$ . (Photomicrographs courtesy W. A. Wissler, Union Carbide and Carbon Research Laboratories, Inc., Niagara Falls, N. Y.)

*a.* (Upper left) Worked and annealed Hastelloy A (53% Ni – 22% Fe – 22% Mo – 1% Si – 2% Mn). Etched with  $\text{H}_2\text{Cr}_2\text{O}_4 + \text{HCl}$ . Structure consists of particles of either carbides or a nickel-molybdenum or nickel-iron-molybdenum secondary solid solution in a nickel-rich primary solid solution matrix.

*b.* (Upper right) Worked and annealed Hastelloy B (60% Ni – 6% Fe – 32% Mo – 1% Si – 1% Mn). Etched with  $\text{H}_2\text{Cr}_2\text{O}_4 + \text{HCl}$ . Structure consists of particles of either carbides or a nickel-molybdenum secondary solid solution in a nickel-rich primary solid solution matrix.

*c.* (Lower left) Cast Hastelloy C (51% Ni – 6% Fe – 17% Cr – 19% Mo – 1% Si – 1% Mn – 5% W). Etched electrolytically with 1% aqua regia in water. Structure is mostly a cored nickel-rich solid solution.

*d.* (Lower right) Cast Hastelloy D (85% Ni – 3% Cu – 1% Al – 10% Si – 1% Mn). Etched with 10% chromic acid. Structure consists of dendrites of light etching nickel-rich solid solution in a background composed of an intimate mixture (probably eutectic) of nickel-rich solid solution and a compound, probably  $\text{Ni}_5\text{Si}_2$ .

forms, but the D alloy is available only in the form of castings. Metallographic structures typical of these alloys are illustrated in Fig. 453.

The range of properties that can be secured with the Hastelloys is shown in Table XXVII.

TABLE XXVII THE RANGE OF MECHANICAL PROPERTIES OF THE HASTELLOYS

	TENSILE STRENGTH, PSI	YIELD STRENGTH (0.2% OFF- SET), PSI	ELONGA- TION, % IN 2 IN.	BRINELL HARDNESS (10 MM- 3000 KG)
<i>Hastelloy A</i> , rolled and annealed	110,000-120,000	47,000-52,000	48-40	200-215
forged	110,000-150,000	50,000-115,000	48-18	—
cast	69,000-78,000	43,000-45,000	12-8	160-200
<i>Hastelloy B</i> , rolled and annealed	130,000-140,000	60,000-85,000	45-40	210-235
cast	75,000-82,000	55,000-57,000	9-6	190-230
<i>Hastelloy C</i> , cast	72,000-80,000	45,000-48,000	15-10	220
<i>Hastelloy D</i> , cast	36,000-41,000	36,000-41,000	0	500-550*

\* Rockwell C50-55.

The properties of alloys A and B are retained well at elevated temperatures as indicated both by short-time and creep tests.

Hastelloy A has fair machinability but alloys B and C can be machined only at comparatively slow speeds. Alloy D is nearly unmachinable, and must be ground.

Hastelloy A resists best the action of all concentrations of hydrochloric acid up to 160 F (70 C); and Hastelloy B will resist all concentrations of the acid up to the boiling point. Hastelloy C resists all oxidizing solutions well, especially those containing chlorides, as well as sulfurous and phosphoric acids. It is one of the few metals that will resist hypochlorites and moist chlorine. Hastelloy D will resist boiling sulfuric acid up to 50% concentration, and concentrations from 50-100% up to 160 F (70 C), somewhat better than the other three, but they all are recommended for this use. Relatively mild conditions, such as exposure to the atmosphere, fresh or salt water, and neutral or alkaline salts have practically no effect on any of the four alloys.

The wrought forms, A and B, can be softened after work-hardening by quenching from 2100-2150 F (1150-1180 C). After this treatment the alloys are essentially solid solutions in nature, although they will contain some free carbides. They will be soft, and will have the best resistance to corrosion. Both alloys may be worked either hot or cold. Alloy C may be

annealed to soften and improve machinability by air cooling from 2 hr at 2150–2200 F (1180–1200 C). Alloy D will have a low impact strength, and a Rockwell hardness of C50–55 as cast. By heating at 1850 F (1000 C) for 3 hr and furnace cooling, the hardness will be reduced about 10 points, the brittleness decreased, and the impact strength increased appreciably without reducing the corrosion resistance.

### ILLIUM

The alloy Illium<sup>30</sup> was developed originally by the Burgess-Parr Company to satisfy a need for a nonporous machinable alloy which would withstand the attack of both nitric and sulfuric acids. At present both cast and wrought forms are made, having the rather complex compositions shown below:

	% NI	% CU	% FE	% CR	% MO	% SI	% MN	% W
<i>Illium R</i> , wrought	60	3	8	21	5	1	1	1
<i>Illium G</i> , cast	58	6	6	21	6	1	1	1

Typical metallographic structures are shown in Fig. 454 for both the wrought and cast alloys.

The cast alloys develop tensile strengths of the order of 60,000 psi and have a hardness of about 200 Brinell or Rockwell B90. The wrought Illium R alloy will have a strength of 100,000 psi annealed and 150,000 psi hard-rolled, with an annealed elongation of about 30% in 2 in. The alloys are machinable, using super-high-speed tools.

The Illium alloys are practically free from corrosion under mild conditions. They are particularly resistant to highly oxidizing conditions such as nitric acid, and have a number of applications in resisting hydrochloric acid and acid chlorides in concentrations up to about 15% at atmospheric temperatures.

### KONAL

Considerable promise has been shown by two precipitation-hardening alloys which are also heat-resisting: *Konal*, containing 73% Ni–17% Co–

<sup>30</sup> Registered trade-mark.



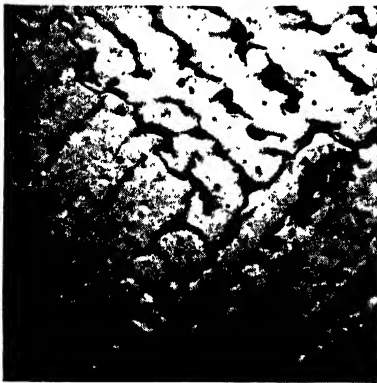
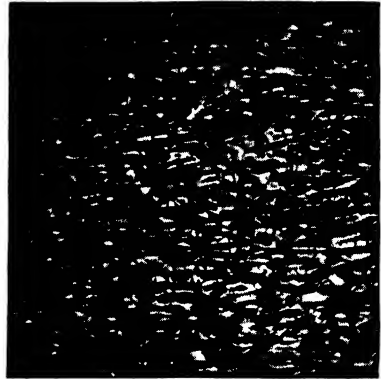
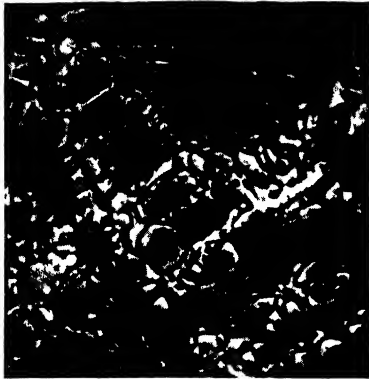


FIGURE 454. Metallographic structures of Illium alloys. Etched with nitric and acetic acids.  $\times 50$ . (Photomicrographs courtesy Burgess-Parr Company.)

*a.* (Upper left) Cast Illium R (60% Ni - 3% Cu - 8% Fe - 21% Cr - 5% Mo - 1% Si - 1% Mn - 1% W).

*b.* (Upper right) Work-hardened Illium R.

*c.* (Lower) Cast Illium G (58% Ni - 6% Cu - 6% Fe - 21% Cr - 6% Mo - 1% Si - 1% Mn - 1% W).

7.5% Fe-2.5% Ti; and *K42B*, containing 46% Ni-25% Co-19% Cr-7.5% Fe-2.5% Ti.<sup>31</sup>

The particular merit of the alloys lies in their ability to retain mechanical properties at elevated temperatures in combination with an excellent oxidation resistance and creep strength. For example the data in Table XXVIII were reported on tests made after water quenching from 1740 F (950 C) and aging for 72 hr at 1200 F (650 C). A comparison of the creep strength of *K42B*, at 1470 F (800 C), with that of the stainless steels is given in Fig. 426.

Both alloys can be worked readily, hot or cold, but have not been used widely commercially because of their cost and the lack of much service or experience. Typical metallographic structures, after quenching the hot-worked materials from 1740 F (950 C) are shown in Fig. 455.

<sup>31</sup> The characteristics of these materials have been discussed thoroughly by C. R. Austin and others, *Trans. A.I.M.E.*, **99**, 1932, 78-96; *Trans. A.S.M.*, **24**, 1935, 451-481; *Journ. Iron & Steel Inst.*, London, **173**, 1938, 177-217. See also P. H. Brace, *Metal Progress*, **41**, 1942, 354-360. They are patented alloys of the Westinghouse Electric Corp.

TABLE XXVIII MECHANICAL PROPERTIES OF KONAL AND K42B AT ROOM TEMPERATURE AND 1110 F (600 C) AFTER A SUITABLE QUENCHING AND AGING TREATMENT

	KONAL		K42B	
	ROOM TEMPERATURE	1110 F (600 C)	ROOM TEMPERATURE	1110 F (600 C)
Tensile strength, psi	108,000	76,800	167,800	127,100
Yield strength (0.2% offset), psi	58,000	46,000	104,000	86,000
Proportional limit, psi	27,500	15,000	70,000	57,500
Elongation, % in 2 in.	35.0	24.5	29.0	21.5
Reduction in area, %	59.5	33.0	37.0	21.5

## OTHER COMPLEX SUPER-HEAT-RESISTANT ALLOYS

An alloy containing, nominally, 65% Co-30% Cr-5% Mo, which was developed originally for dental castings, was used during World War II for many severe heat-resisting applications, such as turbo-supercharger buckets, gas turbine blades, parts for jet engines, and similar parts which are relatively small, require accurate dimensions, have intricate shapes and sections, are subjected to severe dynamic and thermal stresses, and for which a reasonably high cost could be justified.

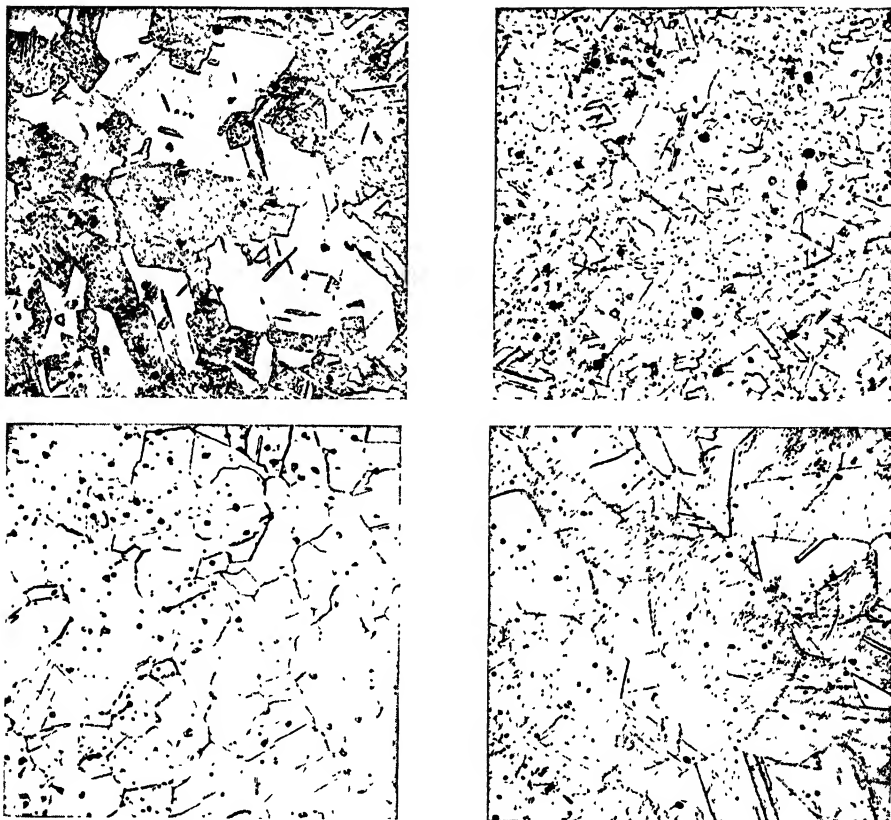
This material, sold commercially under the trade names of *Vitallium* and *Stellite No. 21*, is nonmachinable and nonforgeable and, hence, is almost always made by the precision- or investment-casting process. It combines excellent corrosion-, heat-, and abrasion-resistant characteristics.

At room temperature, the Rockwell hardness will be about C20-36, depending upon the exact composition, with a tensile strength of 90,000-110,000 psi, a yield strength of 52,000-85,000 psi, and an elongation of 2-12%. At 1500 F (820 C), the strength drops to about 65,000 psi but the elongation and reduction in area are relatively high, about 30-35%. In creep tests, a load of 9500 psi produced an elongation of 1% in 1000 hr at 1500 F (820 C). The alloy is scale-resistant to 2100 F (1150 C) and has an excellent resistance to heat shock.

In addition to Vitallium the two alloys most widely used for this type application were *Hastelloy B* (65% Ni-30% Mo-5% Fe), which has already been discussed briefly, and the alloy known as *S-816*.<sup>32</sup> This has the nominal composition 44% Co-20% Cr-20% Ni-0.40% C-4% Mo-4% W-4% Cb-4%<sup>33</sup> Fe-1.5%<sup>33</sup> Si, and a tensile strength of about 70,000

<sup>32</sup> This alloy is described well by Thomas Y. Wilson, *Materials and Methods*, 24, 1946, 885-890.

<sup>33</sup> Max



**FIGURE 455.** Metallographic structures typical of the Konal type of alloys. Etched electrolytically with  $\text{HNO}_3\text{--}4\text{HCl--HAc--H}_2\text{O}$  etchant to which was added  $1\frac{1}{2}$  g cupric ammonium chloride per 100 ml solution.  $\times 300$ . All specimens rapidly cooled after 15 min in hydrogen at 1740 F (950 C). The structures of all of them show varying amounts of the compound  $\text{FeTi}_2$  in a nickel- or cobalt-rich solid solution matrix. It is this compound which appears to contribute largely to the high temperature strength of the alloys. Some nonmetallic inclusions are also present in all the specimens.

a. (Upper left) Konal (73% Ni – 17% Co – 7.5% Fe – 2.5% Ti).  
 b. (Upper right) K42B (46% Ni – 25% Co – 19% Cr – 7.5% Fe – 2.5% Ti).  
 c. (Lower left) 2907 (46% Ni – 25% Co – 19% W – 7.5% Fe – 2.5% Ti).  
 d. (Lower right) 3124 (85% Co – 11.25% Fe – 3.75% Ti). (From C. R. Austin and H. D. Nickol, *Journ. Iron & Steel Inst.*, London, 137, 1938, 177–221, photomicrographs courtesy C. R. Austin.)

psi at 1500 F (820 C). Adequate creep data are not yet available for use. S-816 is an age-hardenable alloy which requires a solution heat treatment at 2300 F (1260 C) followed by water quenching and aging for 6–16 hr at about 1400 F (760 C) to develop its best properties. In addition to the commercial production as billets and bars, this alloy is an excellent mate-

rial for precision casting. In the cast form it can be used at temperatures somewhat higher than the 1500 F (820 C) that seems to be about the limit for the wrought materials. The alloys *S-590* (20% cobalt) and *S-588* (cobalt-free) are less complex and expensive than *S-816* but also have somewhat inferior strength properties.

Several other alloys are also under development<sup>34</sup> but little information is as yet available concerning them. Nearly all of them, however, are complex alloys, usually containing various combinations of chromium, nickel, iron, cobalt and molybdenum as major constituents and much smaller amounts of tungsten, columbium, and sometimes molybdenum as minor constituents. Several of these have tensile strengths higher than 60,000 psi at 1500 F (820 C) and creep data at this temperature indicating a rate of 0.00001% per hr under a load as high as 10,000 psi have been secured.

#### LEAD ALLOYS

The four largest uses of metallic lead: for storage batteries, cable sheathing, piping and roofing, and acid handling equipment, all are based to a large extent upon its corrosion resistance. In addition this characteristic influences the use of considerable amounts of the metal in automobile and railway equipment, and for ammunition, terne plate, and foil. The chief disadvantages of lead and its alloys for most purposes are, of course, its high specific gravity and its low strength.

#### SOFT LEAD

The usual chemical or soft lead is a relatively pure metal, containing less than 0.1% of other impurities, chiefly copper. Chemical lead is covered by A.S.T.M. Standard B29.

The mechanical properties of soft lead are very sensitive to the amount of impurity present, the presence of only a few hundredths of a per cent producing marked changes. Depending upon this factor, properties may be obtained in the relatively wide ranges shown in Table XXIX. The purer leads, naturally, will have the lower strengths and hardnesses and the higher workabilities. The strength properties are so low that soft lead can be used satisfactorily only if it is properly supported. Hence alloyed leads are employed more frequently. The commonest of these alloys contain one or more of the elements antimony, barium, calcium, or tellurium.

<sup>34</sup>See, for example, Carl I. Schweizer, *Materials and Methods*, 24, 1946, 642-645; and Harold A. Knight, *ibid.*, 24, 1557-1563.



FIGURE 456. Metallographic structure of tellurium lead (0.05% Te - 0.06% Cu - rem. Pb), cold rolled 50%. Etched with HAC+H<sub>2</sub>O<sub>2</sub>. X50. (Photomicrograph courtesy Research Department, American Smelting and Refining Company.)

The structure of pure lead is typified by that shown in Fig. 69a. However, metallographic specimens are extremely difficult to prepare except by special techniques, such as the microtome or electrolytic polishing. Lead flows so easily and recrystallizes so close to room temperature that ordinary mechanical polishing methods are practically out of the question.

In general, the corrosion resistance of soft lead is best under conditions, such as exposure to neutral and acid solutions, which favor the formation of protective carbonate or oxide coatings. Since such protective coatings are soluble in alkaline solutions, the resistance of the metal to

these is poorer. In strong acids, such as sulfuric and phosphoric, lead will also develop highly corrosion-resistant surface layers, and for this reason huge quantities of it are used in the chamber process for making sulfuric acid. The most serious failures of lead have been the result of corrosion fatigue rather than of corrosion alone.

TABLE XXIX RANGE OF PROPERTIES USUALLY OBTAINED WITH SOFT LEAD

Tensile strength, psi	1,400-2,800
Yield strength (0.5% elong.), psi	700-1,600
Max tensile load for indefinite time, psi	410-690
Elongation, % in 2 in.	50-70
Reduction in area, %	88-100
Brinell hardness (10 mm-500 kg)	3-5.5

The joining of lead and its alloys by fusing parts together, either with or without added lead, is known as *lead burning*, an art requiring considerable skill.

#### TELLURIUM LEAD

The addition of about 0.06% tellurium to lead forms an eutectic mixture, and gives an alloy having physical properties better than those of ordinary

lead.<sup>35</sup> Furthermore, tellurium raises the temperature of rapid recrystallization of lead well above room temperature, and hence permits the alloy to be hardened by cold-work. This is shown by the metallographic structure of the worked alloy in Fig. 456. Hardening produced in this manner will gradually decrease with time, however, because recrystallization will proceed very slowly even at room temperature. Even this softening with time has certain advantages because it is accompanied by a definite increase in ductility. Properties of tellurium lead, in the form of rolled commercial sheet, will average:

	TESTED AFTER 1 DAY	TESTED AFTER 90 DAYS
Ultimate tensile strength, psi	4,030	3,800
Elongation, % in 2 in.	8	23

Because of the strengthening effect of cold-work and the increased resistance to bending accompanying it, this alloy has been used to a considerable extent in cable sheathing and in chemical plants. The resistance to sulfuric acid appears to be somewhat better than that of ordinary chemical lead, and the alloy also tends to have a finer grain size, which gives increased resistance to fatigue stresses.

#### ANTIMONIAL LEAD

The lead-base alloy containing 1% antimony, which is used widely for cable sheathing, is one of the oldest of the harder lead alloys. The alloy can be age-hardened to some extent; and, after slow cooling and aging for 1 month at room temperature, will have a tensile strength of 2750–3050 psi, with an elongation of 30–40% in 2 in. After quenching from about 480 F (250 C) a strength of 2800 psi will be secured, but this can be increased to about 6000 psi or better by aging at room temperature.

#### CALCIUM LEAD

Lead alloys containing 0.025–0.04% calcium also have properties which make them useful for storage batteries, telephone- and power-cable sheathing, and bearings. These materials are particularly useful in storage bat-

<sup>35</sup> See W. Singleton and B. Jones, *Journ. Inst. Met.*, London, **51**, 1933, 71–80.

teries because, both anodically and cathodically, they behave like pure lead in a battery cell, and are appreciably stronger and stiffer. In addition, they sulfatize more slowly than the usual lead-antimony alloy plates.<sup>36</sup> The alloys age-harden at room temperature after being quenched from about 400 F (205 C). Their properties depend, to a large extent, on the calcium content as shown for tensile strength in Table XXX.

TABLE XXX EFFECTS OF VARYING AMOUNTS OF CALCIUM ON THE TENSILE STRENGTHS OF QUENCHED, AND QUENCHED AND AGED LEAD

% CA	QUENCHED FROM 400 F (205 C), PSI	QUENCHED AND AGED 7 DAYS AT ROOM TEMPERATURE PLUS 16 HR AT 212 F (100 C), PSI
0.04	3,000	5,300
0.12	4,600	8,200
0.20	5,400	6,500

Rapid quenching is not entirely necessary as castings can be aged to comparable strengths. The calcium-lead alloys also appear to have an appreciably higher fatigue-endurance limit than, and a corrosion resistance that is about the same as, pure lead.

#### ALUMINUM ALLOYS

Certain aluminum alloys, all of which may be improved by heat-treatment, retain a relatively large proportion of their strength and hardness at elevated temperatures of the order of those which exist in internal combustion engines, i.e., 500–600 F (260–315 C). For this reason they find numerous applications in aircraft and Diesel engines for such parts as pistons, cylinder heads, crank cases, and similar castings. The choice of both alloy and temper will depend upon the type of manufacturing process desired, e.g., casting or forging, and the service conditions to be withstood.

#### CAST ALUMINUM PISTON ALLOYS

The light weight and good thermal conductivity of aluminum pistons are their principal advantages over the cast-steel and cast-iron pistons with

<sup>36</sup> See, for example, E. E. Schumacher and G. S. Phipps, *Trans. Electrochem. Soc.*, **68**, 1935, 309–316; H. E. Haring and V. R. Thomas, *ibid.*, **68**, 1935, 293–307.

which they compete. Their chief disadvantage has been their high coefficient of thermal expansion. This characteristic has been overcome, however, by proper design and alloying.

The most important of these materials are the Aluminum Company of America Alloys 122, 142 and A132 which contain, in addition to aluminum:

ALCOA NO.	% CU	% MG	% FE	% NI	% SI
122	10	0.25	1.2	—	—
142	4	1.5	—	2.0	—
A132	0.8	1.0	0.8	2.5	12

The mechanical properties of these alloys may vary considerably depending upon the heat-treatment that they have received. However, data for all three alloys in the form of heat-treated permanent-mold castings, even after being held at the temperatures indicated for long periods of time, will fall within the limits indicated in Table XXXI for the five temperatures shown.

TABLE XXXI RANGE OF PROPERTIES OF SOME ALUMINUM PERMANENT-MOLD CASTINGS AT TEMPERATURES UP TO 600 F (315 C)

	75 F (24 C)	300 F (150 C)	400 F (205 C)	500 F (260 C)	600 F (315 C)
Tensile strength, psi	36,000– 40,000	31,000– 37,000	23,000– 28,000	15,000– 18,000	9,000– 11,000
Yield strength (0.2% offset), psi	28,000– 35,000	22,000– 33,000	13,000– 22,000	9,000– 12,000	5,000– 6,000
Elongation, % in 2 in.	0-0.5	0-1	1-2	2-10	8-30
Brinell hardness(10mm-500 kg)	100-140	—	—	—	—

In general, heat-treated sand castings will have lower strengths but about the same elongations as shown.

ALUMINUM-COPPER-IRON-MAGNESIUM ALLOY

Alcoa 122 is the oldest of the automotive piston alloys, and is usually cast into permanent molds although sand castings requiring wear-resisting



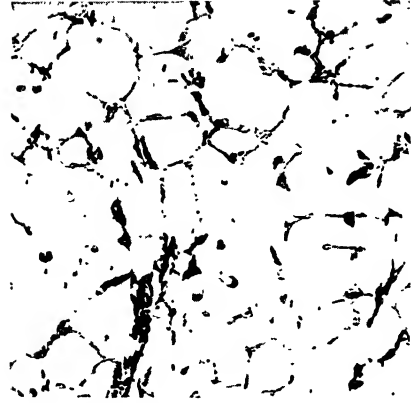
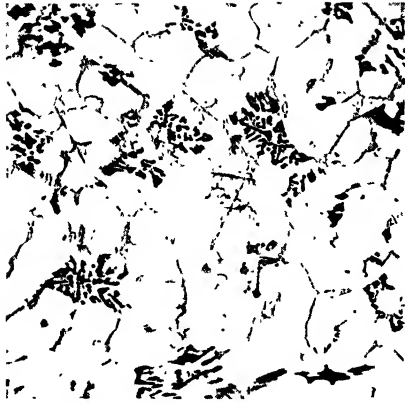


FIGURE 457. (*Left*) Metallographic structure of sand-cast aluminum alloy 122 (10% Cu - 0.2% Mg - 1.2% Fe - rem. Al). Etched with  $\frac{1}{2}\%$  HF.  $\times 100$ . (Photomicrograph by P. O. Percival.)

FIGURE 458. (*Right*) Metallographic structure of sand-cast aluminum alloy 142 (4% Cu - 1.5% Mg - 2% Ni - rem. Al). Etched with  $\frac{1}{2}\%$  HF.  $\times 100$ . (Photomicrograph by D. Hughes.)

characteristics also are made from it. It is covered, in the heat-treated conditions, by A.S.T.M. Tentative Standards B26-T (alloy CG1), B108-T, B179-T, and by S.A.E. No. 34. The alloy combines good machining properties with satisfactory casting characteristics. It also possesses good mechanical properties and wear resistance at piston operating temperatures. In addition to pistons, it is used for air-cooled cylinder heads, pump housings, valve guides, sole plates for flatirons, and other applications where the combination of good machinability, high hardness, and wear resistance is desired.

The structure of the alloy, shown in Fig. 457, consists principally of an eutectic network, composed of  $\theta$  ( $\text{CuAl}_2$ ) and aluminum-rich solid solution, surrounding a dendritic aluminum-rich solid solution matrix. However, because of the iron content and the silicon, which is always present as an impurity in amounts of about 0.25%, some of the dark etching Al-Fe-Si constituent is also present.

#### “Y” ALLOY

The aluminum-copper-nickel-magnesium alloy, 142, is used widely today for sand-cast cylinder heads for air-cooled aircraft engines although it was developed originally for pistons. It also can be used for permanent mold casting. Because of the fact that it undergoes no appreciable change in dimensions during aging it has a much greater dimensional stability in

use than the other piston alloys although its coefficient of thermal expansion is fairly high. The mechanical properties begin to fall off at temperatures above 300 F (150 C) although they are retained fairly well up to 500 F (260 C). The alloy is covered by A.S.T.M. Tentative Standards B26-T (alloy CN21), B108-T, B179-T, and by S.A.E. No. 39.

The metallographic structure, shown in Fig. 458, has a network of the  $\theta$ (CuAl<sub>2</sub>), NiAl<sub>3</sub>, and X constituents at the grain boundaries of a dendritic aluminum-rich solid solution matrix. The long feather at the bottom of the photograph is NiAl<sub>3</sub>.



FIGURE 459. Metallographic structure of permanent-mold cast aluminum alloy A132 (0.8% Cu - 1% Mg - 0.8% Fe - 2.5% Ni - 12% Si - rem. Al). Etched with 1/2% HF.  $\times$  100. (Photomicrograph by G. A. Fisher.)

#### LO-EX ALLOY

This aluminum-silicon-nickel-copper-magnesium permanent-mold casting alloy, A132, is covered by A.S.T.M. Tentative Standards B108-T (alloy SN41) and B179-T and by S.A.E. No. 321. It has a much lower coefficient of expansion than the older piston alloys, and was developed for this reason. Most cast aircraft pistons now are being made of it. However, a special casting technique is required because of the great tendency toward internal shrinkage. The alloy has a high hardness and excellent wearing properties, both of which also make it desirable for pistons. Its utility can be increased appreciably by anodically coating the surface to a depth of about 0.0005 in. This layer absorbs oil, and keeps a lubricant on the bearing surface at all times. The mechanical properties fall off rapidly with temperature, but remain relatively stable at about 60% of their room-temperature values in the range 250-500 F(120-260 C).

The machinability of this alloy is not so good as that of the other two alloys, tool wear being heavy because of the hard silicon particles which appear scattered throughout the structure. However, by using tungsten carbide tipped tools satisfactory results can be secured.

The metallographic structure (Fig. 459) shows chiefly the aluminum-silicon eutectic with a few small patches of NiAl<sub>3</sub>. The other elements are in solid solution in the aluminum, although they might affect the structure by forming minor constituents with any impurities that were present.

## FORGED ALUMINUM PISTON ALLOYS

Two aluminum piston alloys have been developed which possess the general heat-resisting characteristics of the cast alloys but which are primarily intended for forging. The first of these, 18S, containing 4% Cu-0.5% Mg-2% Ni-rem. Al, is a modification of 142, and the second, 32S, containing 0.9% Cu-1% Mg-0.9% Ni-12.5% Si-rem. Al, is a modification of A132.

Although the metallographic structure of these alloys is similar to those of the cast compositions their mechanical properties are superior to those of the castings at room temperatures but will be inferior above 300 F (150 C). Typical properties, in the heat-treated condition, are shown in Table XXXII.

TABLE XXXII RANGE OF PROPERTIES OF SOME ALUMINUM FORGING ALLOYS AT TEMPERATURES UP TO 700 F (370 C)

	75 F (24 C)	300 F (160 C)	500 F (260 C)	700 F (370 C)
Tensile strength, psi	56,000- 63,000	39,000- 49,000	8,000- 11,000	3,000- 4,000
Yield strength (0.2% offset), psi	46,000- 47,000	33,000- 44,000	6,000- 7,000	2,000- 2,500
Elongation, % in 2 in.	8-17	9-10	32-50	85-120
Brinell hardness (10 mm-500 kg)	100-115	—	—	—

In each case values for 18S-T61 (boiling water quench) will average near the high side and values for 32S-T6 near the low side of the range shown.

In addition to its other characteristics 32S has a lower coefficient of thermal expansion than any of the other wrought aluminum alloys.

## CAST CRANKCASE AND CYLINDER-HEAD ALLOYS

In addition to the 142 alloy, two other compositions are used for both sand and permanent-mold castings requiring the characteristics consistent with intricate pressure-tight castings, combined with moderate corrosion resistance and good retention of mechanical properties up to about 400 F (205 C). Typical applications requiring these characteristics would be liquid-cooled cylinder heads for automotive, aircraft, and Diesel engines, water jackets, cylinder blocks, water-cooled exhaust manifolds, structural

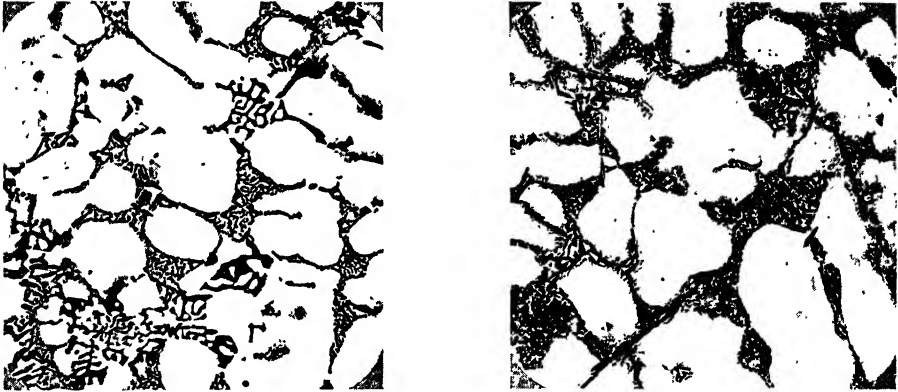


FIGURE 460. Metallographic structures of sand-cast and heat-treated aluminum alloys A355-T51 (1.4% Cu - 5% Si - 0.5% Mg - 0.8% Ni - 0.8% Mn - rem. Al), *left*, and 355-T6 (1.3% Cu - 5% Si - 0.5% Mg - rem Al), *right*. Etched with Keller's reagent.  $\times 100$ . (Photomicrographs courtesy Aluminum Research Laboratories.)

fittings, and miscellaneous engine parts. Alloy A355, containing 1.4% Cu-5% Si-0.5% Mg-0.8% Ni-0.8% Mn-rem. Al, is used for applications requiring the best retention of properties at elevated temperatures, and 355, in which the nickel and manganese are not present, is used for applications in which the heat resistance is of lesser importance.

At room temperature, sand castings made of either alloy will have a tensile strength of about 28,000 psi, with a yield strength of about 23,000 psi, and an elongation of about 1.5% in 2 in. As the testing temperature increases the tensile strength decreases to about 13,000 psi at 400 F (205 C), with a yield strength of 10,000 psi, and an elongation of about 8% in 2 in.

Alloy 355 falls within the limits of S.A.E. Standard No. 322 and A.S.-T.M. Tentative Standards B26-T (alloy SC21) and B179-T. In addition several commercial alloys of secondary grade are sold that can be made entirely from segregated scrap with a minimum of pure ingot blending.

Typical microstructures of the A355 and 355 alloys in the heat-treated condition (Fig. 460) will contain patches of the aluminum solid solution- $Mg_2Si$  eutectic and possibly some free silicon in a dendritic matrix of aluminum-rich primary solid solution. The A355 alloy will also contain some dark etching  $NiAl_3$ , and other constituents will inevitably be present in minor amounts in both alloys because of the impurity content.

#### CONTROLLED-EXPANSION ALUMINUM PISTONS

At one time one of the most serious objections to aluminum alloy pistons in automotive and airplane internal combustion engines resulted from

their relatively high coefficient of thermal expansion, especially in comparison with that of the customary cast-iron cylinder liners. Because of this a relatively large clearance had to be allowed between the piston and the cylinder wall in order to eliminate any danger of seizing at the high operating temperatures. This meant that until the motor warmed up there was considerable piston slap, cylinder wear, and excessive oil pumping.

Improvement was made by modifications in piston design to include slots and grooves at strategic points. These would permit the clearances to be decreased, because they would allow for a greater amount of deformation of the alloy at operating temperatures. The use of *Invar* struts to hold down the lateral expansion, with increasing temperature, to a rate comparable to that of the cylinder block enabled the difficulty to be almost completely overcome, although this method has not been adopted generally because of the high cost. For this purpose a nickel content of 32–34% gives better results than the standard 36% nickel *Invar* alloy.

#### *For Further Study Refer to*

1. *The Book of Stainless Steel*, 2d ed., edited by E. E. Thum: American Society for Metals, Cleveland, Ohio, 1935.
2. *Stainless Iron and Steel*, 2d ed., by J. H. G. Monypenny: John Wiley & Sons, Inc., New York, 1931.
3. *Metals Handbook*: American Society for Metals, Cleveland, Ohio, 1939 (usually published triennially). A new edition will appear in 1948.
4. *The Steel Physical Properties Atlas*, by C. N. Dawe: American Society for Metals, Cleveland, Ohio, 1936.
5. *The Corrosion Resistance of Metals and Alloys*, by R. J. McKay and R. Worthington: Reinhold Publishing Corporation, New York, 1936.
6. *The Corrosion of Iron and Steel*, by J. C. Hudson: D. Van Nostrand Company, Inc., New York, 1940.
7. *Corrosion, Causes and Prevention*, by F. N. Speller: McGraw-Hill Book Company, Inc., New York, 1935.
8. *Digest of Steels for High Temperature Service*, 4th ed.: The Timken Roller Bearing Co., Canton, Ohio, 1939.
9. *Compilation of Available High Temperature Creep Characteristics of Metals and Alloys*: Joint Committee A.S.M.E. and A.S.T.M., Philadelphia, Pa., 1938.
10. *Nickel and Nickel Alloys*: The International Nickel Company, Inc., New York, 1941.

11. *Metal Progress*: American Society for Metals, Cleveland, Ohio (published monthly).
12. *Materials and Methods* (formerly *Metals and Alloys*): Reinhold Publishing Corporation, New York (published monthly).
13. *Alcoa Aluminum and Its Alloys*: Aluminum Company of America, Pittsburgh, Pa., 1947.
14. Publications of:
  - Allegheny-Ludlum Steel Corp., Brackenridge, Pa.
  - Aluminum Company of America, Pittsburgh, Pa.
  - American Rolling Mill Co., Middletown, Ohio.
  - Bethlehem Steel Co., Bethlehem, Pa.
  - Burgess-Parr Co., Freeport, Ill.
  - Carpenter Steel Co., Reading, Pa.
  - Crucible Steel Co. of America, New York, N. Y.
  - Duriron Co., Inc., Dayton, Ohio.
  - The Electro-Alloys Co., Elyria, Ohio.
  - Firth-Sterling Steel Co., McKeesport, Pa.
  - Haynes Stellite Co., Kokomo, Ind.
  - International Nickel Co., Inc., New York, N. Y.
  - Jessop Steel Co., Washington, Pa.
  - Latrobe Electric Steel Co., Latrobe, Pa.
  - Michigan Steel Castings Co., Detroit, Mich.
  - National Lead Co., New York, N. Y.
  - Permanente Metals Corp., Oakland, Cal.
  - Republic Steel Co., Cleveland, Ohio.
  - Reynolds Metals Co., Louisville, Ky.
  - Rustless Iron & Steel Corp., Baltimore, Md.
  - St. Joseph Lead Corp., New York, N. Y.
  - The Midvale Co., Philadelphia, Pa.
  - Universal-Cyclops Steel Corp., Bridgeville, Pa.
  - U.S. Steel Corporation, New York, N. Y.

## Alloys For Applications Requiring High Strength And Toughness

**B**ECAUSE OF THE HUGE TONNAGE OF METALS USED IN THE building and transportation industries the *alloys of construction* are probably the most important group for the engineer to consider. These are the high-strength alloys, combining with this property toughness and corrosion resistance to a degree dependent upon the specific application. Within this group are included the usual wrought structural alloys, those automotive alloys which are used for such parts as shafts, connecting rods, gears, pinions and springs, and various castings which are good engineering materials of this type.

### RELATIVE STIFFNESS

For many constructional applications, it is desirable to have the load carried with the minimum deflection possible. This stiffness factor applies in most design formulae and is a very important one. Stiffness is determined largely by the section modulus of the shape used and by the modulus of elasticity of the alloy. Although the modulus of elasticity depends on the composition of the alloy, the moduli of most engineering alloys containing relatively small percentages of alloying elements are quite similar to that of the dominant metal. This fact is of great importance in the selection of the proper group of alloys to be considered for any specific application, because the necessities of design usually limit the possible moduli to a relatively narrow range.

The load which produces a given deformation is composed of two parts: a *dead load*, which is inherent in the structure itself because of its construction, and a *live* or *pay load*, which is the load it can carry in addition to its own weight. Obviously, the live load is the commercially important one,

and attention must be directed by the engineer toward making it as large as possible with reference to the necessary dead load, which should be kept to a minimum. A structure which will suffer the maximum allowable deflection under its own weight is of no real engineering value, except for possible ornamental purposes. Because of this it should be clear that a lightweight alloy, with a low modulus, could well be equivalent to an alloy which had a much higher modulus, but which also weighed much more. It is on this basis that aluminum- and magnesium-base alloys have been able to compete so successfully with the much stronger steels. This factor, sometimes called the *relative modulus of elasticity*, can be expressed by considering the ratio of the modulus of elasticity to the specific gravity, as shown in Table XXXIII.

TABLE XXXIII ACTUAL AND RELATIVE STRENGTH PROPERTIES OF SOME ENGINEERING ALLOYS

STRUCTURAL MATERIAL	SPECIFIC GRAVITY	MODULUS OF ELASTICITY, PSI		TENSILE STRENGTH, PSI		YIELD STRENGTH, PSI	
		<i>Actual</i>	<i>Relative*</i>	<i>Actual</i>	<i>Relative*</i>	<i>Actual</i>	<i>Relative*</i>
Dowmetal E	1.8	6,250,000	3,500,000	48,000	27,000	34,000	19,000
72% Be-28% Al	2.0	29,000,000	14,500,000	25,000	12,500	19,000	9,500
Alcoa 24S-T36	2.8	10,000,000	3,600,000	65,000	23,000	47,000	17,000
Hiduminium R.R. 77	2.8	10,000,000	3,600,000	78,000	28,000	67,000	24,000
Alcoa 75S-T6	2.8	10,000,000	3,600,000	77,000	27,500	66,000	23,600
18:8 Stainless steel	7.9	26,000,000	3,300,000	150,000	19,000	120,000	15,000
"K" Monel	8.9	26,000,000	2,920,000	150,000	16,900	110,000	12,400
Mild alloy structural steel	7.9	30,000,000	3,800,000	80,000	10,100	55,000	7,000
Silicon bronze	8.7	15,000,000	1,730,000	90,000	10,400	50,000	5,800
Carbon structural steel	7.9	30,000,000	3,800,000	60,000	7,600	30,000	3,800
Cast iron	7.1	15,000,000	2,100,000	50,000	7,000	—	—
Rolled zinc	7.2	14,000,000	1,950,000	44,000	6,100	—	—
Tin alloys	7.3	6,000,000	820,000	15,000	2,100	—	—
Lead alloys	11.0	2,500,000	230,000	4,000	360	2,000	180

\* The *relative* properties are secured by dividing the *actual* properties by the specific gravity.

It can be seen at once that, of the eight engineering metals, the most likely structural materials will be alloys based upon iron, nickel, aluminum, or magnesium. Alloys of copper possibly may compete for special applications only, but lead, tin, and zinc are practically out of the question.



The choice between the four leading materials then must be made upon the basis of such factors as ease of fabrication and assembly, cost, corrosion resistance, availability, and suitability. It is at once clear, also, why the commercial development of the new alloys of beryllium with about 28% aluminum,<sup>1</sup> which combine a low specific gravity with a modulus of elasticity of about 29,000,000 psi, is awaited so eagerly, and why the alloys of the R.R.77 and Alcoa 75S types were preferred to the better known 24S for many applications when they became commercially available.

#### RELATIVE STRENGTH

Another factor which frequently must be considered is the relative strength of a given weight of a material. Approximate values for this also are given in Table XXXIII. It can be understood readily that, for any given application, structural members can be designed in different materials on the basis of equal weight or on the basis of equal volume. In the former case, the light alloy member would be much larger; and, therefore, probably able to carry larger loads if it were designed properly. In the latter case the load-carrying capacity might be the same, but the weight of the light metal alloy structural member, despite its comparatively low strength, probably would be very much less than that of the heavier and stronger alloys.

#### IMPORTANCE OF DESIGN

The engineering design is of equal importance with the choice of the metal which permits its realization. Just as the metals must compensate for the indeterminant factors in the design, so the design should utilize as efficiently as possible the properties and characteristics of the metals which are available.

For example, the inherent lack of stiffness of a given type of material that has desirable lightness of weight or corrosion resisting characteristics often can be compensated for by proper section design. In fact, one manufacturer has made and patented a built-up section (Fig. 463) which is equal to solid sections in strength and rigidity, even though it has but a fraction of their weight. Simpler methods, such as those involving the use of corrugations, embossing, flanges, or stiffening ribs (cf. Fig. 296), also are used extensively.<sup>2</sup> Further information on the importance of design can be

<sup>1</sup> See C. B. Sawyer and B. Kjellgren, *Metals and Alloys*, 11, 1940, 163-167.

<sup>2</sup> See, for example, Chap. 21E in Ref. 7 at the end of this chapter for a more complete discussion of some of these factors with reference to stainless steel.

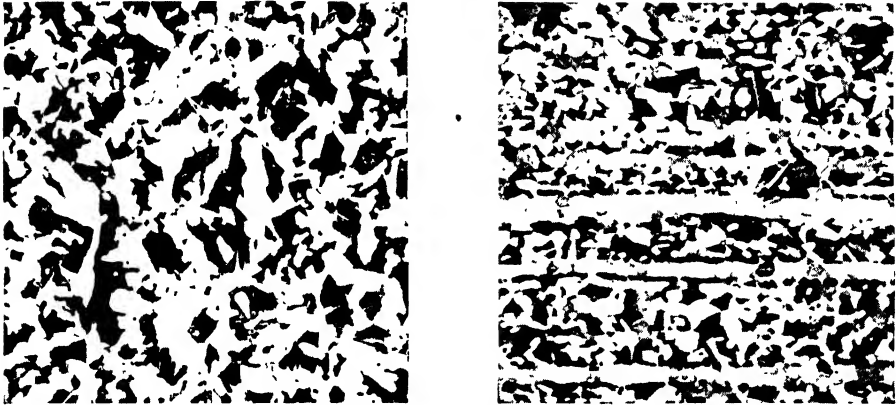


FIGURE 461. Metallographic structures of normalized plain carbon structural steels containing about 0.25% carbon. Etched with nital.  $\times 250$ .

a. (Left) Transverse section.

b. (Right) Longitudinal section, showing banding.

secured best from the makers of given types of alloys as it is a subject which they have studied extensively.

### *Structural Steels*

#### PLAIN CARBON STRUCTURAL STEEL

The plain carbon structural steels, with the exception of wire for bridge cable which runs considerably higher, generally contain 0.15–0.40% carbon. In the hot-rolled condition, in which these alloys frequently are used, their metallographic structure (cf. Fig. 223) will be composed of pearlite and ferrite in amounts that can be approximated readily by use of the lever rule. Typical microsections are shown in Fig. 461. In particular the banded structures characteristic of hot-rolled material should be noted. This banding is caused by carbon and impurity segregation.

With the usual composition for the riveting grades of 0.20–0.35% carbon, 0.15% silicon, and 0.50% manganese, plates or bars will have a tensile strength of 60,000–70,000 psi, with a yield point of about half this, and an elongation of 25–20% in 2 in. The higher carbon steels of 0.40–0.45% carbon would have a tensile strength of about 85,000 psi, with the yield again about half this value, and an elongation of 15–10%. However, they also would have a much lower impact resistance. In addition, the formability of the higher carbon varieties is lower, making them much more difficult to bend and flange, and their tendency to air-harden is

undesirable because it is apt to cause embrittlement in welding as well as to require more or less careful control of cooling after hot-rolling.

Carbon structural steel plates, bars, and sections are covered by several A.S.T.M. Standards among which may be mentioned: A7 (Bridges and Buildings), A113 (Locomotives and Cars), and A131 (Ships). Tentative Standard A283-T (Plates) also applies.

#### NICKEL STRUCTURAL STEEL

The nickel structural steels are probably the oldest of the alloy structural steels. The introduction of nickel enables a lower carbon to be used for an equivalent strength, in comparison with plain carbon steels, thus giving an alloy of much greater ductility because of the correspondingly smaller amount of iron carbide present.

A common analysis, covered by A.S.T.M. Standard A8, contains 0.43% carbon (max), 0.80% manganese (max), 3.0–4.0% nickel, and, in the hot-rolled condition, will have a minimum yield point of 55,000 psi with an ultimate strength of 90,000–115,000 psi and an elongation of about 20% in 8 in. By halving the carbon and manganese contents, however, the strength properties will be decreased about one quarter without changing the elongation greatly.

The higher carbon alloy also will have about twice the notched impact strength of ordinary low-carbon structural steel, but will be suitable only for assembly by riveting. For welding, a carbon less than 0.15% and a manganese about 0.30% must be used.

The biggest objection to these steels is their cost since nickel is a comparatively expensive alloying element. They have the advantage, however, of many years of service experience. Metallographically, they are very similar to the plain carbon steels although their grain size is usually somewhat smaller than that of the nickel-free alloys for a comparable treatment.

#### MEDIUM MANGANESE STRUCTURAL STEEL

As a structural steel which would give properties equivalent to those of the nickel steels and at lower cost, the medium manganese structural steels were developed. In these the carbon is held at 0.25–0.35% and the manganese is increased to 0.75–1.75% with the lower manganese accompanying the higher carbon and vice versa. This type of steel, as covered by A.S.T.M. Standard A195, will have a tensile strength of 68,000–82,000 psi, with a minimum yield point of 38,000 psi, and an elongation of at least 20% in 8 in. This is a riveting grade of steel.

## OTHER STRUCTURAL STEELS

Other varieties of structural steel have been used in the past and are still being used to some extent, although the general class of mild-alloy steels, which has been developed in recent years, will probably replace the original types almost entirely in time.

The alloys containing 0.50–1.0% chromium,<sup>3</sup> and the so-called silicon structural steels containing 0.25–1.25% silicon and 0.60–0.90% manganese with 0.25–0.35% carbon, are the commonest steels of this type. With these materials, yield points of 45,000–65,000 psi, and ultimate tensile strengths of 80,000–95,000 psi, combined with elongations of 22–16% and notched impact values equivalent to those of low-carbon structural steels, can be secured. These steels are acceptable for riveted structures, but their ductility is somewhat low for cold-forming and they are welded with some difficulty. The silicon type is covered by A.S.T.M. Standard A94.

The chromium-molybdenum S.A.E. grade (*X4130*) containing 0.28–0.33% carbon, 0.40–0.60% manganese, with 0.80–1.10% chromium and 0.15–0.25% molybdenum also is used for structural purposes but under the same restrictions as above.

## THE MILD-ALLOY STRUCTURAL STEELS

Demands for increased corrosion resistance and better weldability necessitated a further modification of the structural steel analyses to give a *welding grade* alloy which contained 0.07–0.15% carbon. These alloys frequently contain, in addition, somewhat higher phosphorus contents than the usual structural steels although the sum of the carbon and phosphorus has to be kept below 0.25% in order to eliminate static brittleness.

Many mild-alloy modifications of these welding grades are used, containing various combinations of copper, chromium, nickel, molybdenum, vanadium, silicon, and manganese, usually in small amounts, but their mechanical properties all are nearly the same in commercial thicknesses of plates, as rolled. Typical alloys would have a yield point of 50,000–60,000 psi, with an ultimate strength of 70,000–80,000 psi, and 28–23% elongation. The notched impact values would be at least equal to those of 0.20% carbon structural steel. Alloys of this type fall within A.S.T.M. Standard A242.

The original carbon contents of 0.15–0.22% are retained in a *riveting grade* of these mild-alloy steels which also is made with various combina-

<sup>3</sup> These and their improved, modern modifications are discussed by W. Crafts, *Trans. A.I.M.E.*, 135, 1939, 473–485.

tions of alloying elements to increase its mechanical properties and corrosion resistance.

Some of the more common mild-alloy steels which are now available in commercial thicknesses of plates as rolled are: *Cromansil*, *Cor-Ten*, *Man-Ten*, *Yoloy*, *Inland Hi-Steel*, *Jal-Ten*, *Armco High Tensile*, *Konik*, *Mayari R*, *A.W. Dyn-El*, *N-A-X-High Tensile*, *Otiscoloy*, *Republic Double Strength Grades 1 and 1A*, *Granite City HS1 and HS2*, and *Central High Tensile*, as well as several others not identified by special names.

These steels have been used widely in bridges and similar structures, and in shipbuilding. Their application in lightweight passenger and freight cars as well as in streetcars, trucks, and busses is also of importance because it has increased markedly the efficiency of these carriers. The alloys are used principally in places where heat-treatment is difficult, impossible, or undesirable. Their applications, no doubt, will increase greatly in the future when larger sections become available, and when more is made known about their weldability and general reactions to treatment under more diversified conditions.

#### SOME FACTORS AFFECTING THE SELECTION OF MILD-ALLOY STEELS

Since engineering designs are frequently far ahead of the materials available it is not surprising that the mild-alloy steels were well received by the engineering profession as a whole.<sup>4</sup> Their high yield points and their additional corrosion resistance, which made it possible to reduce section thicknesses somewhat and so take advantage of the higher yield points, seemed to make them ideal materials for fulfilling the advanced designs for low dead-weight transportation units of all types. Naturally, these designs had included welding rather than riveting as the natural method of assembly in order to be consistent in their weight-saving objectives, and it was at this point that trouble was first encountered.

Although steels containing above 0.15% carbon can be satisfactorily welded if suitable precautions are taken, this carbon content has been set by the American Welding Society as the upper limit for producing satisfactory toughness in the affected zone near the weld.<sup>5</sup> The addition of the alloying elements had the usual effects, even though this was not clearly understood until fairly recently:<sup>6</sup> (a) they modified the iron-carbon constitutional diagram thereby giving even 0.15% carbon much more impor-

<sup>4</sup> For a discussion of factors to be considered in selecting these compositions see S. Epstein, J. H. Nead, and J. W. Halley, *Trans. A.I.M.E.*, 120, 1936, 309-339.

<sup>5</sup> See *Welding Handbook*, 1939 ed., American Welding Society, Cleveland, Ohio, J. H. Critchett, Chap. 25, p. 451; A. E. Gibson and J. C. Hodge, Chap. 26, p. 464.

<sup>6</sup> See R. H. Aborn, *Welding Journal*, 19, 1941, 414S-426S.

tance than it ordinarily would have; and (b) they decreased the rate of austenite decomposition into pearlite on cooling.

This means, essentially, that a welded joint of a mild-alloy steel, especially in the relatively thin sections that often are used, would have a much better chance of becoming embrittled during cooling than a similar joint made of a plain carbon structural steel. Naturally, embrittlement is the least desired characteristic in a welded joint. The only methods for preventing weld embrittlement were to maintain a low-carbon content or to use some means of retarding the cooling sufficiently to allow the austenite to transform normally to pearlite in all regions that had been heated above the critical, regardless of whether or not they were in the actual weld. This could be accomplished either by preheating the weld zone, and thereby furnishing additional heat to be lost by radiation and conduction, or by using insulated covers, electrical or gas heaters, or any of the similar methods for inducing slow cooling. Also with these alloys the stress-relieving temperatures and subsequent cooling rates had to be modified from carbon-steel practice.

This is an excellent example of the necessity of using metallurgical methods for solving engineering problems, because no real attack on the problem of welding these materials could be made, other than the obvious cut-and-try methods, until the metallurgical reasons for the trouble had been uncovered.

For proper welding, the hardenability of the steel is very important but in just the reverse sense from its importance in heat-treatment. In welding it is desired to minimize hardness penetration rather than to accentuate it. Since the alloying elements are necessary in order to secure the improved mechanical and chemical characteristics, slower rates of cooling must be adopted if the weld zone is to be kept pearlitic or lower carbon contents must be used if it is to be kept ferritic.

When the carbon content is reduced as much as is practical from a steel-making viewpoint, hardenability becomes of much less importance and solid solution hardening of the ferrite by the alloying elements of much greater importance. Welding grades of these steels, therefore, should preferably be sufficiently low in carbon, manganese, and all the other elements which increase hardenability markedly to minimize the formation, as the weld cools, of the harder low-ductility products of austenite transformation. At the same time, however, the alloying elements which are present must be soluble in the ferrite and so harden it to such an extent that the steel is appreciably stronger than plain carbon steel after slow cooling. Preferably these alloying elements also should increase the corrosion resistance of the ferrite since applications involving steels of this type usually are designed

for a yield point of at least 50,000 psi and a proved resistance to corrosion is necessary if these design values are to be utilized to best advantage.

Today any of these mild-alloy steels can be satisfactorily welded if the proper precautions are taken, but the trouble involved may not be economically practicable for certain applications, particularly if the carbon runs high (0.15%). However, it must not be forgotten that different combinations and amounts of alloying elements exert different effects on the hardenability. Hence, the fact that one type of mild-alloy steel cannot be welded economically for a given application does not imply that another type might not prove to be entirely satisfactory. Thus, a proper balance still must be maintained even though mechanical properties and weldability are now the two main factors involved.

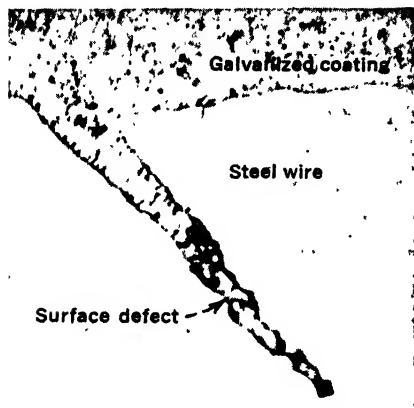
#### BRIDGE CABLE

Cable wire, such as that used in suspension bridges, usually is made of steel of a much higher carbon content than is used for the other structural alloys. A common analysis will contain 0.75–0.85% carbon, 0.50–0.70% manganese, 0.10–0.20% silicon and 0.04% (max) of phosphorus or sulfur. This wire usually is made in the basic open-hearth furnace, hot-rolled, and finished by cold-drawing with intermediate patenting heat-treatments. These processes all must be controlled closely if the required combination of high tensile strength, toughness, and fatigue resistance is to be secured. The finished wire usually is galvanized, formerly by hot dipping but now more frequently by electrolytic methods.

The mechanical properties required in bridge cable, averaging about 220,000 psi tensile strength, with a yield point of at least 144,000 psi, an elongation of 4–8% in 10 in., and a reduction in area of 30%, can be produced in three different ways: (a) by cold-drawing, (b) by quenching and tempering, and (c) by austempering. The standard, time-tried method, always has utilized cold-drawing, and cable prepared by this method has been uniformly satisfactory. Although no attempts have been made to use the austempering treatment for this application, heat-treated wire, in general, has not been looked upon with favor since the failure of the initial attempts to use quenched and tempered wire in the Mt. Hope and Ambassador bridges in 1929.

Several articles<sup>7</sup> have been written in explanation of these failures and it seems to be established that the main causes were threefold:

<sup>7</sup> See, for example, E. E. Thum, *Metal Progress*, 22, June 1932, p. 45, July 1932, p. 27, August 1932, p. 30, Sept. 1932, p. 43; 30, August 1936, p. 67; also W. H. Swanger and G. F. Wohlge-muth, *Proc. A.S.T.M.*, 36, 1936, and *Metal Progress*, 30, 1936, 59–67; and G. Brewer, *Metal Progress*, 44, 1943, 441–447.



	Heat Treated	Cold Drawn
Modulus	29,400,000	28,200,000
Proportional limit	99,700	84,200
Yield point	189,800	182,600
% Elongation in 2 inches	6.1	6.6
% Reduction in area	37	40
Rockwell hardness	C-46	C-44

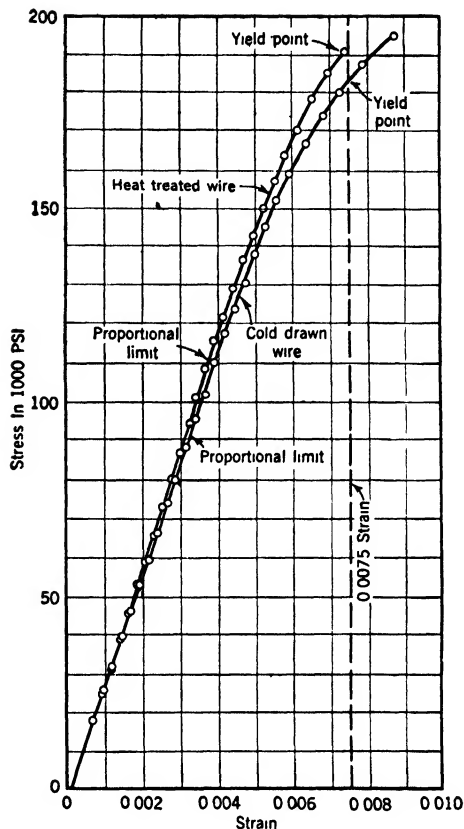


FIGURE 462a. (Upper left) Relatively deep cracks, filled with zinc or zinc-iron compound, which occurred frequently in the heat-treated wire. Longitudinal section.  $\times 500$ . b. (Lower left, right) Stress-strain curves of two varieties of bridge wire of equal ultimate strength. Average of ten determinations. Note low modulus and proportional limit of cold-drawn wire. (Courtesy National Bureau of Standards.)

1. The heat-treated wire contained many more surface imperfections than the cold-drawn wire and each of these, especially after galvanizing, as illustrated in Fig. 462(a), acted as a notch to concentrate the stresses, both residual and applied.
2. The cold-drawn wire possessed greater ductility and a lower proportional limit, yield point, and elastic modulus than the heat-treated wire, as shown in Fig. 462(b), all properties which assisted it to deform plastically under the residual bending stresses produced when the wires were formed around the anchorage shoes, and so at least partially to relieve those stresses.
3. The heat-treated wire was so stiff it had to be preformed in order to lie snugly against the anchorage shoes whereas the cold-drawn wire



would "lie dead" without this treatment. This preforming resulted in high residual bending stresses in the outer fibers of the heat-treated wire, where the imperfections were most pronounced. These high residual stresses could not be relieved by plastic flow because of the low ductility.

The net effect of this combination of factors was the cracking of the bridge wires even before they were completely in position. It was necessary, therefore, to remove them and replace them with cold-drawn wire.

Whether or not austempered wire protected by electrogalvanizing would be subject to similar defects, which would result in its failure, has never been determined, largely because of the understandable reluctance of bridge constructors to take the risk.

#### STRUCTURAL USES OF 18:8 STAINLESS STEEL

The exceptional resistance to corrosion of 18:8 stainless steel has made it very popular as an ornamental material in building construction. The Empire State and Chrysler buildings in New York City are two excellent examples of its use in this manner.<sup>8</sup> A wide range of finishes is possible so, in addition, it is also suitable for many interior applications such as ornamental trim, stainproof kitchen and laundry fittings and accessories, bank vaults, and all kinds of utensils and equipment for handling foodstuffs.

Although its high strength properties and corrosion resistance have enabled the use of thinner gauges of this material than were feasible with most other competing alloys, and although its high modulus of elasticity (26,000,000 psi) coupled with the thinner gauges made it a definite competitor, on paper, of the lighter constructional alloys of aluminum, it remained for engineering design to make competition possible. The use of *shot welding* coupled with the built-up beam (Fig. 463), has enabled it to compete with the other alloys in the lightweight structural field, especially in the transportation industries.

A typical built-up section, as shown in Fig. 463, is made entirely of thin-gauge sheet but still, because of its ingenious assembly and the use of corrugations to increase stiffness, this beam has a better rigidity and strength than a solid I-beam of structural steel two and a half times its weight. Entire railroad-car frames have been constructed of these members, in such a way as to utilize to the fullest extent the inherent rigidity of this structure.<sup>9</sup> The use of thin corrugated sheet as a sheathing material has similarly served to decrease dead weight.

<sup>8</sup> See, for example, W. Van Alen in Chap. 20 of Ref. 7 at the end of this chapter.

<sup>9</sup> See E. J. W. Ragsdale in Chap. 21E of Ref. 7 at the end of this chapter.

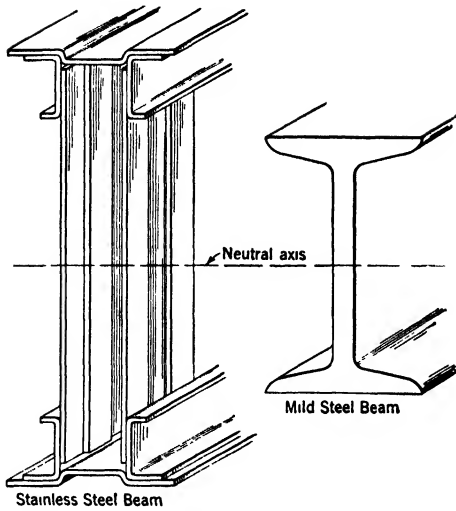


FIGURE 463. (Left) Beams, drawn to scale, with same moments of inertia. The box girder at left is welded of 18:8 strip, weighs 38% as much as the 5-in. I-beam of structural steel at right, and has an ultimate strength  $2\frac{1}{2}$  times as great. Even when figured with factors of safety of 6 and 4 respectively it will carry a 50% greater bending moment.

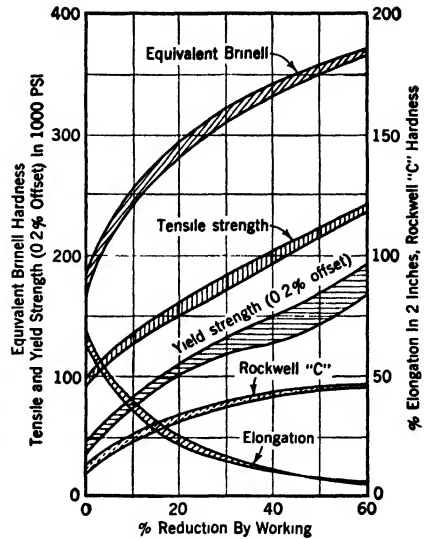


FIGURE 464. (Right) Influence of cold-working on some mechanical properties of an 18:8 type stainless steel.

#### FABRICATION OF STAINLESS STEEL

The 18:8 stainless steels can be rolled, both hot and cold, to thin-gauge sheets. Deep-drawing is performed readily with a good surface finish as long as the grain size is kept small. A large grain size will give the typical *orange-peel surface* which is difficult and expensive to remove by subsequent polishing. In order to produce this desired small grain size, the annealing temperature must be kept as low as possible, because the grain size is apt to coarsen rapidly if annealing is carried out above about 1975 F (1080 C).

Because of its rapid work-hardening characteristics, the alloy requires special die design and a comparatively high forming pressure. Heavily formed alloys, especially of the 18:8 analysis, are apt to crack spontaneously unless they are annealed subsequently to remove strains.<sup>10</sup>

#### MECHANICAL PROPERTIES

Because of their constitution, as discussed in Chap. XV, the austenitic stainless alloys can be hardened only by mechanical work. They do not

<sup>10</sup> See L. W. Hostettler in Chap. 6G, of Ref. 7 at the end of this chapter.

respond to heat-treatment. The effects of cold-work are summarized in Fig. 464 for a typical composition. Tensile strengths in the range 100,000–250,000 psi, which are obtained easily by this method, have made the alloy an important structural material.

When used in the annealed (quenched) state, however, strength is not too important, and the chief advantage over mild steel lies in the increased corrosion resistance which permits some reduction in sheet thickness, a greater amount of thickness decrease being permissible in the cold-rolled condition than in the annealed condition. This decrease in thickness, accompanied by a decrease in weight, is permissible as long as the alloy retains its strength and its stainless properties. Consequently, although fabrication by riveting is satisfactory, welding may introduce some difficulty because of this factor. Unfortunately the use of rivets adds appreciably to the weight, and thus counterbalances the advantage obtained by using the thinner gauge. In addition, the heating incident to hot riveting is no more beneficial than that incident to welding, and hence the riveting must be done cold if the corrosion resistance is not to suffer adversely.

Fatigue endurance limits of 18:8 stainless steel roughly parallel the tensile strength, high-endurance limits accompanying high strengths. Consequently, when high-endurance limits are desired, best results are secured either by using the alloy in the hot-rolled condition (the usual finishing temperature is about 1650 F (900 C)) or else after annealing the cold-worked alloy at as low a temperature as possible. When annealed by air cooling from 1950–2100 F (1070–1150 C) the endurance limit is only about one half of the value obtained for the hot-rolled condition.<sup>11</sup> Consequently annealing temperatures in the range 1700–1900 F (930–1040 C) are preferable.

#### EFFECT OF CARBON UPON MECHANICAL PROPERTIES

The properties of 18:8 stainless steel in the annealed condition are markedly affected by the carbon content<sup>12</sup> as indicated in Table XXXIV. For reasons of corrosion resistance, as discussed in Chap. XV, the carbon content usually is kept as low as possible but these data cover fairly well the range that may be encountered, particularly if there has been carbon pickup during welding or heat-treatment.

<sup>11</sup> See T. S. Fuller in Chap. 17D and C. A. Scharschu in Chap. 14A of Ref. 7 at the end of this chapter.

<sup>12</sup> See C. A. Scharschu in Chap. 14A of Ref. 7 at the end of this chapter.

TABLE XXXIV EFFECT OF CARBON CONTENT ON THE STRENGTH PROPERTIES OF ANNEALED 18:8 STAINLESS STEELS.

% CARBON	TENSILE STRENGTH, PSI	PROPORTIONAL LIMIT, PSI	ELONGATION, % IN 2 IN.	REDUCTION IN AREA, %	BRINELL HARDNESS (10 MM-3000 KG)
0.065	79,000	19,500	70	72	140
0.11	85,000	25,000	69	76	163
0.17	93,000	30,000	68	75	170

#### WORK-HARDENING CHARACTERISTICS OF THE 18:8 TYPE STAINLESS STEELS

Since work-hardening is the only means available for producing the high strengths desired in many of the engineering applications for the 18:8 type stainless steels, especially in the sheet and strip forms, some of the factors affecting it may be of interest.<sup>13</sup> Nickel is the alloying element which has the greatest effect upon the strength characteristics and their increase by work-hardening. For example, in a series of low-carbon (0.05%) annealed alloys containing 17% chromium, the use of 7% nickel will give a tensile strength of about 130,000 psi and 9% nickel 85,000 psi. After cold-working to a 60% reduction the difference between the two has not changed materially, the 7% nickel alloy reaching about 210,000 psi and the 9% nickel alloy 175,000 psi.

Increasing the chromium content to 18% or 19%, on the other hand, will have only a slight effect on the strengths although it does increase the elongation appreciably for the lower reductions.

Increasing the carbon content to about 0.14%, in the range of many of the commercial alloys, will increase the rate of work-hardening, particularly in the 7% nickel alloys. After a cold reduction of about 55% a 17% chromium, 7% nickel alloy containing 0.14% carbon will have a strength of about 255,000 psi, appreciably higher than that secured with the lower carbon alloy. In these higher carbon alloys also an increase in the chromium content, in the range 17-20% chromium, will cause a pronounced drop in the tensile strength, the decrease sometimes being as much as 25% in the heavier reductions, and a somewhat smaller drop in the elongation.

<sup>13</sup> The entire subject of austenitic stainless steels has been well treated by V. N. Krivobok, R. A. Lincoln, and R. Patterson, Jr., *Trans. A.S.M.*, **25**, 1937, 637-689.

This is particularly important in the use of cold-rolled sheet since some bending or other forming operations are frequently necessary.

The differences resulting from changing the chromium and nickel contents are attributable to the effects of these elements on the stability of austenite in this type of alloy. In general, the addition of chromium to an iron, iron-nickel, or iron-nickel-carbon alloy tends to promote the stability of ferrite as a stable phase. On the other hand, the addition of nickel to an iron, iron-chromium, or iron-chromium-carbon alloy tends to promote the stability of austenite as a stable phase. The combined effects of these two alloys with that of carbon, which tends to promote the formation of carbides, makes the entire problem a rather complex one. It appears likely, however, that in the so-called border alloys, i.e., those with 7% nickel, there is some decomposition of the austenite by cold-working and that this is the real explanation of the high work-hardening capacities of these alloys. Depending upon the exact composition, the amount and rate of this "decomposition" by cold-working can vary over relatively wide ranges.

In using these alloys a proper balance must be maintained between the workability required for the fabrication of the rolled material and the strength needed for the design. Usually, therefore, a moderate tensile strength, i.e., 150,000–175,000 psi, is all that can be secured if the elongation is to be reasonably good. The 17:7 type alloy is generally superior to the others in this respect.

The beneficial effects of the border compositions on the work-hardening characteristics were recognized by the establishment of an A.I.S.I. 301 grade (16–18% chromium, 6–8% nickel, 0.08–0.20% carbon) of stainless steel. This is invariably sold by all companies handling the 18:8 grade, and is distinguished from it by 17-7 or 301 designations.

#### EFFECT OF LOW TEMPERATURE ON MECHANICAL PROPERTIES

No decrease in mechanical properties was suffered by 18:8 stainless steels when tested at room temperature after 24 hr immersion in liquid air.<sup>14</sup> When tested at low temperatures they showed the increase in tensile strength found with most steels but also retained considerable ductility rather than becoming extremely brittle as most steels do. For example, at a temperature as low as  $-425$  F ( $-254$  C) an 18:8 stainless steel had a tensile strength of 263,000 psi, with a yield point of 122,700 psi, an elongation of 25%, and a reduction in area of 30.5%.

<sup>14</sup> This general subject was discussed comprehensively by E. W. Colbeck, W. E. MacGillivray, and W. R. D. Manning at the May 24, 1933 meeting of the British Institution of Chemical Engineers.

## WELDING CHARACTERISTICS

Whenever they are heated, as during welding, the cold-worked austenitic stainless steels will tend to soften because of strain recrystallization, and will tend to become sensitized because of carbide precipitation, as discussed in Chap. XV. Both of these factors work to neutralize the advantages of using a thinner gauge sheet with its accompanying lighter weight, since this usage is made possible only by the high strength and corrosion resistance of the alloy. In order to eliminate these difficulties recourse has been made to a very rapid automatic spot-welding process, using very high currents and short times of the order of a fraction of a second. This process has been trade-marked *shot welding*. Although, during this welding, the temperature at the weld itself will be well over 2000 F (1100 C) the combination of the low thermal conductivity of the metal and the short heating time definitely limits the extent to which the heat can flow away from the weld. The presence of cold metal around the weld also will serve to cool it rapidly, and thus prevent the precipitation of carbides.

The appearance of properly and improperly made spot welds of stainless steel is shown in Fig. 465. In the properly made weld (third picture) there are three distinct zones: (a) the *weld zone* itself, in which the characteristic dendritic structure of a casting exists; (b) the *sensitized zone*, where heat penetration from the weld into the base metal has caused carbide precipitation, with accompanying decrease in resistance to corrosion; and (c) the *unchanged base metal* which should surround the weld on all sides and thus protect it from the corroding medium. In the weld that has been made improperly by using too high a temperature, i.e., too high a current and/or too long a time, on the other hand, the sensitized zone penetrates to the surface, thus exposing the sheet to corrosion. Properly made spot welds are tough and ductile, and may be twisted through nearly 90 deg without shearing.

Welding of the austenitic alloys by the shielded-arc process, the customary method, can be done readily by experienced workmen; but the weld, of course, will require heat-treatment subsequently if full corrosion resistance is required. Welding is the preferred method for joining stainless steel wherever it is feasible since it is the only method giving a smooth, permanently tight joint which can be made as resistant to corrosion as the base metal itself. In modern practice one of the stabilized types (see Chap. XV) is always used if assembly is by fusion welding.

*Automotive Steels*

There are two main types of automotive steels, *carburizing* and *heat-treating*, both of which have been used for many years. Although, until

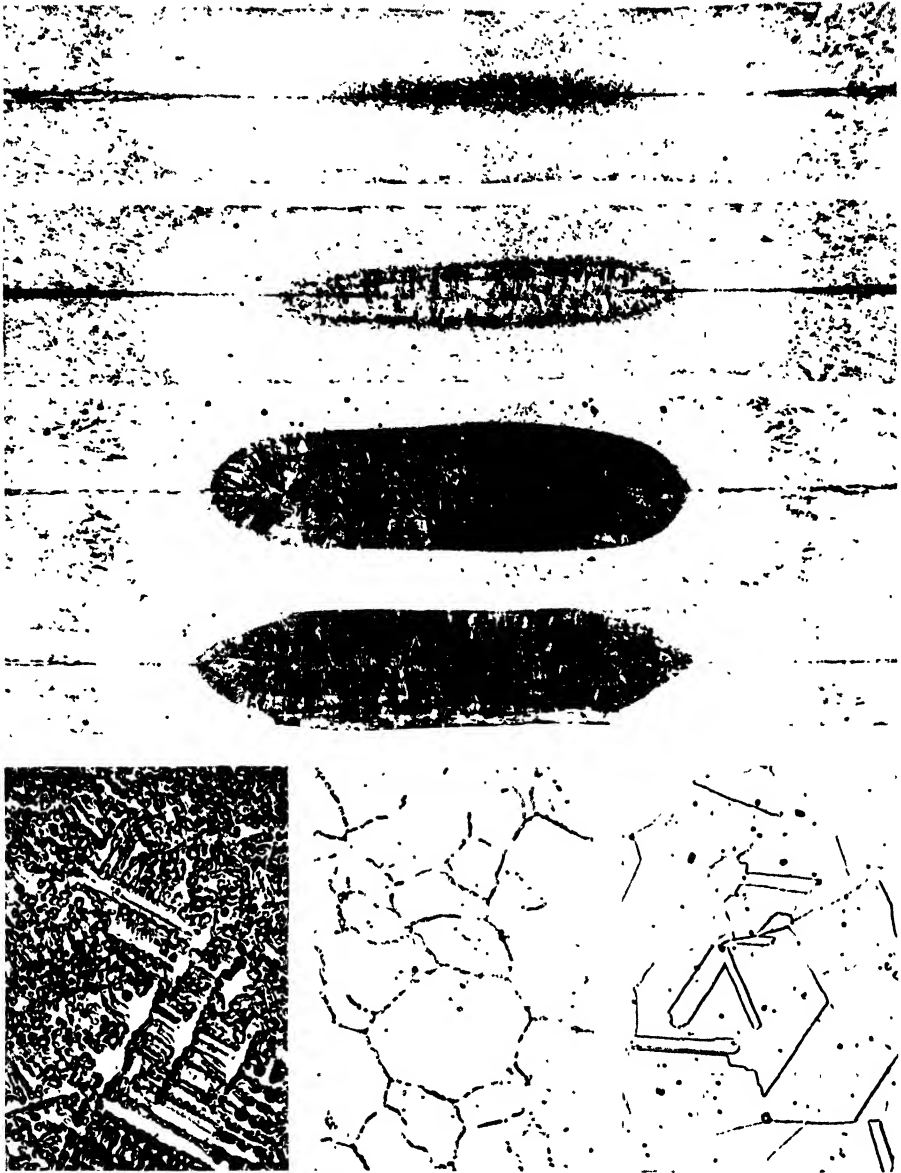


FIGURE 465a. (*Upper group*) Welded areas between two 0.010-in. sheets of 18:8 stainless steel, cross sectioned. Slightly etched.  $\times 38$ . Two samples at top had insufficient heat and are brittle; third sample is correctly made "Shotweld"; bottom sample had too much heat and the surface has been impaired to an extent where corrosion would result.

*b. (Lower group)* Metallographic structures of metal in each of the three zones of the correctly made spot weld. Left, weld zone. Center, heat-affected, sensitized zone. Right, unaffected zone. Etched electrolytically with 2% oxalic acid.  $\times 750$ . (Photomicrographs in *a* courtesy E. G. Budd Manufacturing Company.)

recently, these were primarily standard S.A.E. and A.I.S.I. grades there are now several new N.E. (National Emergency) grades, which may, in time, replace the older grades in many applications.<sup>15</sup>

#### STEELMAKING PRACTICE AND HEAT-TREATMENT

*The automotive steels must be dependable.* Hence they are almost invariably *killed* steels since only in the killed steels can the hardenability and the mechanical characteristics be maintained reasonably uniform. For the same reasons most of them are made in the basic open hearth, although the Bessemer, acid open-hearth, and both the electric-arc and induction processes are used for certain types.

Recommended heat-treatments for all the S.A.E. grades of steels may be found in the S.A.E. Handbook. Essentially, these treatments are specific examples of the general procedures and principles which have been discussed previously.

#### CASE CARBURIZING GRADES

The standard plain carbon carburizing steel is S.A.E. 1020, although the higher manganese variation *X1020* (0.70–1.00% manganese) also is used extensively because of its better machinability and its ability to carburize and harden with less tendency toward soft spots than the 1020 grade. This results, of course, from the already mentioned effects of manganese in decreasing the rate of austenite decomposition. Grades as high as 1040 are carburized also, although to a lesser extent than the lower carbon grades. Typical curves showing the change in carbon content with case depth for an S.A.E. 1020 steel are shown in Fig. 466. Some applications of these steels would be:

1020—Carburized: wrist pins, camshafts, drag links, clutch fingers; and, in the uncarburized form: welded tubing, sheet, strip, and various forged parts where high strength is not essential.

1025—Carburized parts for which large sections are used or in which some core hardness is desired, and for forgings in which much machining is required. In the high manganese variety, *X1025*, the machinability and mechanical properties are much better than in the plain carbon type and are especially suited to applications such as hub and rim bolts and studs.

<sup>15</sup> The National Emergency steels are discussed thoroughly in publications issued by the various steel companies and in the *N.E. Steel Handbook*, Penton Publishing Co., Cleveland, Ohio, 1943. See also C. M. Parker, *Metals and Alloys*, 16, 1942, 622–629.



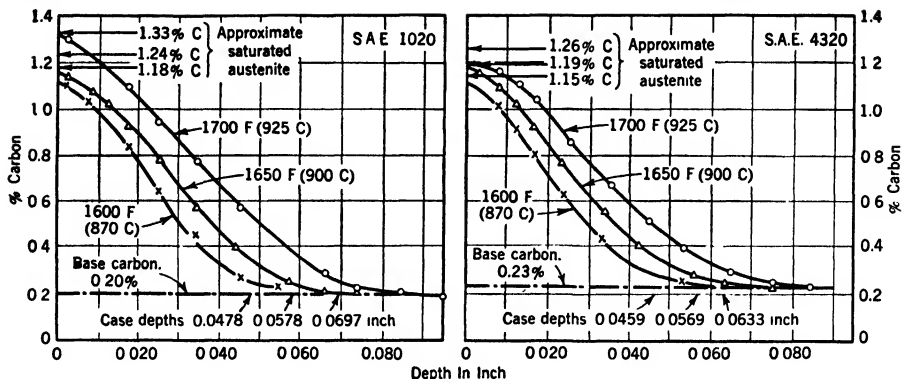


FIGURE 466. Carbon-penetration curves for S.A.E. 1020 and 4320 steels after  $7\frac{1}{2}$  hr at heat in a mixture of 55 parts Drycolene and 8 parts natural gas. (After *Metal Progress* data sheet.)

For applications in which good combinations of strength, toughness, and machinability are desired, the free-cutting grades *1115* (0.70–1.00% manganese, 0.075–0.15% sulfur) and *X1314* (1.00–1.30% manganese, 0.075–0.15% sulfur) are used.

#### ALLOY CARBURIZING GRADES

Although, if enough care were taken, almost any carburized part could be made of a plain carbon steel, it is frequently more convenient to use an alloy steel for some purposes. As discussed previously, this is usually a question of the piece being treated, or of the heat-treating or quenching practice preferred in any particular plant. Alloy price may affect the selection of a particular alloy steel, but, obviously, cannot be the determining factor in eliminating the plain carbon steel from consideration. However, total cost, including labor and overhead charges, might do this, because so many different operations must be considered in each particular application.

In the past, the principal alloy carburizing grades of steel have been:

1. The *nickel steels*: *2015* (0.40–0.60% nickel), *2115* (1.25–1.75% nickel), *2315* (3.25–3.75% nickel), and *2515* (4.75–5.25% nickel). All of these will harden from an oil quench, and hence are used when water quenching is undesirable because prevention of distortion is an important factor, as in gears. In general, the higher the nickel content of these alloys, the greater will be their toughness and strength, and the greater will be their cost. The higher nickel contents also tend to give somewhat lower case hardnesses after quenching than the low nickel contents because of the greater amount of retained austenite

in them. Hence, they must be heat-treated with much greater care, and frequently must be given subzero "cold" treatments to transform the austenite to martensite completely.

2. The *nickel-chromium steels*: 3115 (1.10–1.40% nickel, 0.55–0.75% chromium), 3215 (1.50–2.00% nickel, 0.90–1.25% chromium), 3312 (3.25–3.75% nickel, 1.40–1.75% chromium) and 3415 (2.75–3.25% nickel, 0.60–0.95% chromium). These also are oil-hardening and develop excellent combinations of strength and toughness. The so-called Krupp analysis (3.75–4.00% nickel, 1.50–1.75% chromium), which has been used extensively in this country, is also of this type. In order to minimize distortion and improve machinability, it is advisable to normalize these steels, as well as the higher nickel steels, at least 50° F (30° C) above the carburizing temperature before carburizing. Some typical applications have been for ring gears and pinions, spline and countershafts, rear axles, transmission gearing, and piston rings. In general, the heavier the section or the more severe the usage, the higher will be the percentage of alloying elements used.
3. The *molybdenum steels*: 4320 (1.65–2.00% nickel, 0.40–0.60% chromium, 0.20–0.30% molybdenum), 4615 (1.65–2.00% nickel, 0.20–0.30% molybdenum), and 4815 (3.25–3.75% nickel, 0.20–0.30% molybdenum), which have been used widely in recent years. These are oil-hardening steels with excellent core strengths, surface hardnesses, and good wear resistances. Typical applications are for rear axle gears and pinions in truck and bus transmissions, carburized gears, steering knuckle pins, roller bearings, and other parts where high fatigue and wear resistance and good tensile properties are required. The chromium is present in 4320 to improve the hardness, strength, and wear resistance, especially in heavier sections. Typical carbon penetration curves for a 4320 steel also are shown in Fig. 466. In the higher alloy steels, a slightly higher carbon content is used for the same purpose. The 4815 analysis can be used interchangeably with the 2515 grade for many applications.
4. The *chromium-vanadium steel* 6115 (0.80–1.10% chromium, 0.15–0.20% vanadium). This is a fine-grained type which hardens in oil or water, and is used interchangeably with other steels of similar carbon content for parts such as shafts, rear axles, and transmission gearing.

#### SELECTION OF CARBURIZING STEELS

The selection of the proper carburizing steel composition, case depth, and heat-treatment can be a far more complex problem than would be

anticipated<sup>16</sup> even within the required limits of a hard, wear- or fatigue-resistant surface on a relatively tough and shock-resisting core. Most of the factors involved are more properly related to wear resistance than to strength and toughness and hence will be discussed in Chap. XVII. However, when bending stresses are involved the two factors, core hardness and case depth, are so directly related that simultaneous consideration must be given to them<sup>17</sup> if premature failure from fatigue is to be prevented.

Briefly, this consideration shows that the strength of the part as a whole (case and core) may be increased either by increasing the core strength (hardness) or by increasing the case depth. However, because of the effect of internal stresses the strength of the case increases with its depth only under certain conditions so the more important factor is selection of the proper core strength to resist the service conditions. The minimum suitable case depth should then be used with it. In general, the thicker cases are less desirable than the thinner cases because they require much longer times to produce and are apt to lead to greater internal stresses after hardening and a greater tendency to spalling of the case.

This strengthening of the core can be secured by increasing either the carbon content, the alloy content, or both. Although "carburizing steels" have in the past, generally meant a maximum of 0.25% carbon, today many automotive and other carburized parts are made to withstand higher stresses by the use of steels containing up to 0.40% carbon, frequently with moderate alloying. Carbon alone will not give high core properties except when rapid quenching is used, as with thin sections or drastic cooling. These conditions are apt to lead to high internal stresses and heavy distortion and hence are avoided whenever possible.

A comparatively recent development in the automotive industry, along these lines, has been the use of a 0.35–0.45% carbon alloy steel in a gas carburizing treatment which gives a case of 0.005–0.010-in. depth having a surface carbon content of about eutectoid concentration.<sup>18</sup> The light case provides a high surface hardness to resist wear whereas the high core hardness supplies the carrying capacity for compressive loads and the necessary resistance to alternate bending. In addition to these advantages, the higher carbon contents of the core improve the machinability, if proper heat-treatment is used, over that of the mild-carbon carburizing grades.

<sup>16</sup> This is discussed thoroughly by G. T. Williams in Ref. 6, 1939 ed., pp. 1043–1050, at the end of this chapter.

<sup>17</sup> This was brought out clearly by J. G. R. Woodvine, *Carnegie Scholarship Memoires, The Iron & Steel Inst.*, London, 13, 1924, 197.

<sup>18</sup> This is discussed briefly by A. L. Boegehold and C. J. Tobin, *Trans. A.S.M.*, 26, 1938, 493–509.

## HEAT-TREATING GRADES

The heat-treating grades must contain sufficient carbon and alloying elements to enable them to respond properly to heat-treatment. Thus their hardenability, as discussed in Chap. IX, is usually very important, and all of the many factors which affect this characteristic must be considered in selecting a steel for any given application. It should be emphasized that hardenability is affected also by the shape of the piece being hardened as well as by its section or composition.<sup>19</sup> This is especially true of parts like gears in which all the wearing surfaces must be hardened properly if a satisfactory life is to result. On the more complicated shapes, only experiments in actual hardening can give the most satisfactory procedure to follow, and, at this stage, this is the method usually used for the majority of parts regardless of their shape.

The heat-treating grades usually will include a broader range of carbon contents than the carburizing grades because a wider range of properties and applications is required of them. In general, the alloys containing less than 0.50% carbon are used most widely for forgings, and those containing more than this for springs and similar applications.

## FORGING STEELS

The plain carbon heat-treating steels may range from 0.30–0.70% carbon and 0.40–1.20% manganese, depending on the particular grade. These are the only two elements present which are really significant. Although the plain carbon steels will harden in water, it is not advisable to cool pieces with thin sections or small diameters in this manner as they are very susceptible to quenching cracks.

In the past, the most important grades of forging steel have been:

1. The *plain carbon steels*, 1040, 1045, and 1050. These have fair machinabilities and fair deep-hardening characteristics, and are suited particularly to small- and medium-sized forgings such as crankshafts, starter gears, axle and spline shafts, connecting rods, brake levers, bolts and studs, and similar parts. Larger parts, and those subjected to more severe loading, would be made of the higher carbon grades.

When deep-hardening qualities are not required, and especially when water quenching is desirable in the larger sections, the low man-

<sup>19</sup> This is discussed from a theoretical viewpoint by M. Asimow and M. A. Grossman, *Trans. A.S.M.*, 28, 1940, 949–978.

ganese varieties *X1040*, *X1045*, and *X1050* (0.40–0.70% manganese) are used.

If higher machinabilities are required without loss in the deep-hardening or strength characteristics, the free-cutting steels *X1330*, *X1335*, and *X1340* (1.35–1.65% manganese, 0.08–0.13% sulfur) may be used instead of the plain carbon grades. Likewise, if the dangers of distortion can be lessened by using an oil-hardening steel, the manganese steels *13xx* (1.60–1.90% manganese) may be used interchangeably with the plain carbon steels of similar carbon content.

2. The *nickel steels*, *2330–2350* (3.25–3.75% nickel). In spite of their higher cost these steels often are used when considerable strength and toughness are sought. Some typical applications are for keys, heat-treated bolts, screws, studs, levers, propeller shafts, spline shafts, axle shafts, and gears. The higher the nickel content the greater will be the strength and toughness and the larger the section that can be heat-treated satisfactorily. These steels are oil-hardening, and are somewhat sensitive to heat-treatment.
3. The *nickel-chromium steels* of the *31xx*, *32xx*, *33xx*, and *34xx* groups, containing 0.30–0.50% carbon. These are used when severe service conditions require exceptionally good mechanical and fatigue-resisting properties. They are particularly good for resisting dynamic stresses. Even sections greater than 1- $\frac{1}{2}$  in. diameter are capable of satisfactory heat-treatment in the higher alloy grades. Typical applications are for crankshafts, axle shafts, spline shafts, steering knuckles, connecting rods, and gears. Some of the lower carbon, lower alloy grades can be water hardened satisfactorily, but most of the steels in this group are oil-hardening. Water quenching is not recommended in such instances.
4. The *molybdenum steels* of the *41xx*, *43xx*, and *46xx* grades containing 0.30–0.50% carbon. These are oil-hardening and are particularly useful where high strength and fatigue-resisting properties are required as in heavy duty shafting. Their fine grained characteristics assist materially in minimizing distortion. Typical applications are for axles, steering knuckles, steering knuckle arms, propeller shafts, transmission shafts, forgings and strip for aircraft work, Diesel engine crankshafts, and gears. The higher alloy contents are used principally in the larger sections.

The *4130* alloy as well as *8630*, its equivalent in the N.E. steel group, has found considerable usage in welded aircraft tubing and similar applications because a welded joint of this composition will

harden during cooling, after welding, to a strength equal to that of the steel before welding.

5. The *chromium steels*, 5140 and 5150 (0.70–0.90% chromium). These steels will harden deeply when quenched in oil. They are used interchangeably with the 23xx and 31xx grades for applications such as gears, shafts, thrust washers, and springs which require greater strength and toughness than are obtainable in the plain carbon steels.
6. The *chromium-vanadium steels*, 6130–6150. These are similar to the 51xx grades, except for the addition of about 0.15–0.20% vanadium and are used for similar applications. The vanadium is added primarily to give a clean, fine-grained, tough steel. The addition of more than 0.15% vanadium tends to decrease hardenability somewhat but on the average the 61xx grades have about the same hardenability as the 51xx grades of S.A.E. steels. The 61xx grades do, however, have improved strengths and fatigue resistance, and are used for forgings especially with heavy sections.

#### SPRING STEELS

The spring steels, in general, are similar to the forging grades except for a somewhat higher carbon content. Carbon contents of 0.50–0.70% are customary although they may be somewhat lower in the alloy grades.

Steel for springs may receive its properties by either cold-working, oil tempering, or patenting treatments. Rockwell hardnesses in the range C40–50 usually are recommended.

Typical applications include snap rings, cushion springs, clutch springs, and valve springs. Leaf springs and bumper bars and some of the more rigid coil and seat springs frequently are made of steel of still higher carbon content in the 0.80–0.95% range.

The alloy spring steels are either of the *chromium* (5150) or *chromium-vanadium* (6150) grades, or else of the *silicon-manganese* types (9255 and 9260) which contain 1.80–2.20% silicon and 0.70–0.90% manganese. The manganese usually is kept on the high side of the range for leaf spring sections greater than  $\frac{3}{8}$  in. and on the low side for those smaller than this.

#### MECHANICAL PROPERTIES OF HEAT-TREATED S.A.E. STEELS

It was pointed out in Chap. IX that, in the annealed condition, all low-alloy steels usually will have quite similar properties if they are treated in

such a manner as to have similar structures although, when tempered at the same temperatures, they apparently react quite differently. Because of their different compositions, the S.A.E. automotive steels also react differently to tempering from the essentially completely martensitic structure secured by hardening the section throughout during quenching.<sup>20</sup>

This is true even though the trend is the same in each case, as illustrated in Fig. 467(a) for several oil- and water-hardening varieties. It will be seen readily from this figure that some of the steels may have to be tempered as much as 200° F (95° C) higher than others in order to reach the same tensile strength and hardness.

However, if, instead of comparing the steels on the basis of a constant tempering temperature, they are compared when tempered to a constant tensile strength<sup>21</sup> (or hardness), regardless of the tempering temperature required to produce it, it will be found that an extremely close relationship exists between them. This is illustrated in Fig. 467(b) for the common mechanical properties. The agreement is satisfactory except for the reduction in area data in the higher hardness ranges, where the tensile strengths exceed 200,000 psi.

These statements, naturally, do not hold necessarily when the alloy, section dimensions, and quenching medium are so selected that complete hardening throughout the cross section is not secured during quenching. However, even under these conditions, the properties of one steel can be well approximated by those of another, provided the most suitable, rather than an identical, tempering temperature is used.

For these reasons it seems desirable to repeat the earlier statement that *there are few parts that cannot be made equally as well from a plain carbon steel as from a low alloy steel*. All that is required is a proper appreciation by the designing engineer of the metallurgical factors involved, and possibly a more rigid control of the heat-treating procedures. The selections of the alloy S.A.E. grades are dictated more by convenience than by any superiority of properties. The economics require, as a rule, however, that the cheaper alloy receive more careful treatments than the more expensive alloy grades and vice versa. The selection, therefore, is not entirely arbitrary, but rather one of adaptability to specific manufacturing procedures.

#### NATIONAL EMERGENCY STEELS

It has been found by experience and careful correlation of considerable data that the first small amounts of any given alloying elements, up to

<sup>20</sup> See E. J. Janitzky and M. Baeyertz, pp. 515-518 of Ref. 6, 1939 ed., at the end of this chapter.

<sup>21</sup> Note that this is equivalent to tempering to a similar metallographic structure.

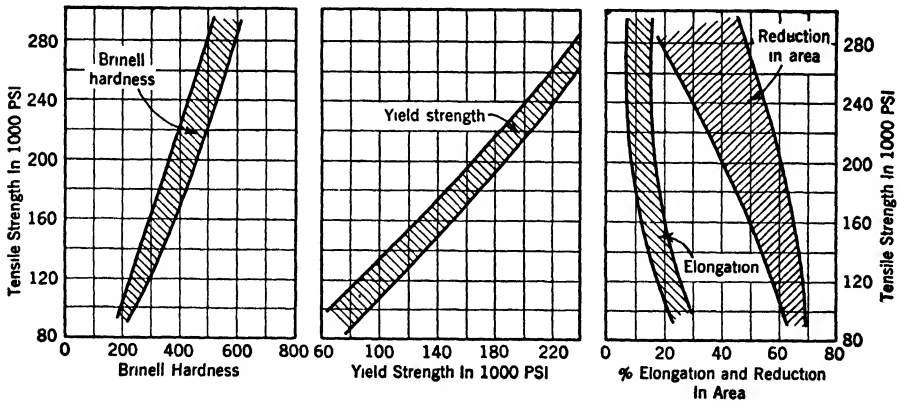
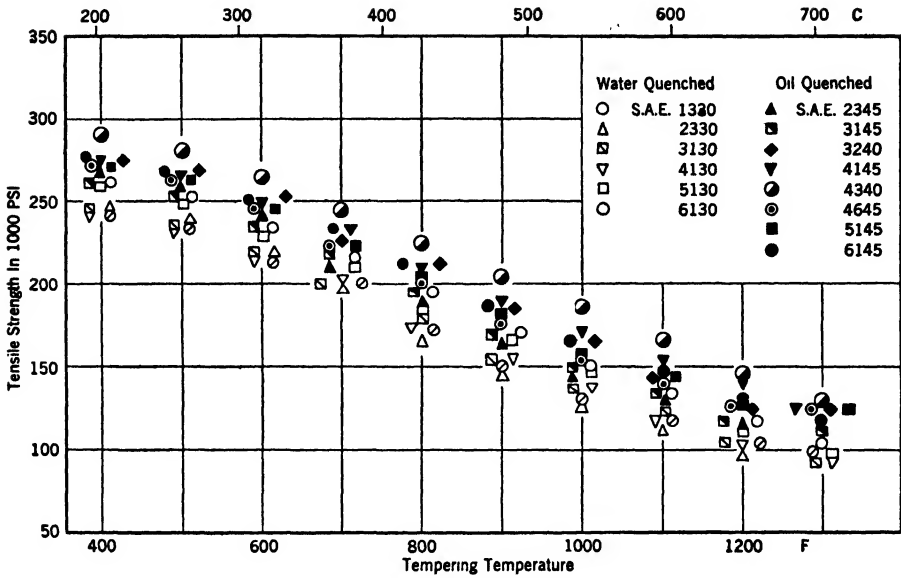


FIGURE 467a. (Upper) Change in tensile strength with increase in tempering temperature for water- and oil-hardening steels. The specimens were held at temperature for 30 min.

b. (Lower) Change in Brinell hardness, yield strength, elongation, and reduction in area with tensile strength. Round bars of 1-in. diameter were normalized, quenched in oil or water according to S.A.E. recommendations, then tempered at various temperatures from 400–1300 F (200–700 C). (From E. J. Janitzky and M. Baeyertz, *Metals Handbook*, courtesy American Society for Metals.)

0.5% in most cases, are much more effective in increasing the hardenability of a steel than any larger amounts of the same element. This has already been discussed briefly in Chap. IX. In fact, if the complete chemical



analysis, including the so-called residual amounts, the as-quenched grain size, the severity of the quench, and the presence or absence of undissolved carbides before quenching are all known, it is possible for the metallurgist to "predict" hardenabilities with fair precision.<sup>22</sup>

In order to conserve certain critical strategic elements, such as nickel, chromium, aluminum, manganese, and vanadium, to use most advantageously the residual alloy content of steel scrap, and to take advantage of this effectiveness of comparatively small amounts of residual elements in increasing the hardenability, the National Emergency steels of the N.E. 8xxx group were announced early in 1942. These included carbon contents in the range 0.15–0.50% as well as the following ranges of other elements in various combinations: 0.70–1.60% manganese, 0.40–0.70% nickel, 0.40–0.60% chromium, 0.10–0.40 molybdenum. In all cases, the limits for silicon were 0.20–0.35% and the maximum limits for sulfur and phosphorus were 0.04% each.

Later the N.E. 94xx and 95xx steels were made available. These alloys conform to the customary S.A.E. nomenclature, containing about 0.80–1.50% manganese, 0.40–0.60% silicon, 0.20–0.60% each of chromium and nickel, and about 0.08–0.25% molybdenum in addition to a carbon content which is indicated, in points, by the last two figures of the designating number in the usual manner. Generally the higher amounts of manganese will accompany the higher carbon contents and vice versa. A N.E. 96xx series, similar to these but containing no nickel or molybdenum, also was made.

Although complete data concerning these steels are not as yet available,<sup>23</sup> members of this group can undoubtedly be found which will duplicate the properties and general characteristics of almost any of the other S.A.E. grades and hence can be substituted for them directly. The principal problem seems to be one of weldability rather than one of mechanical properties. Both of these characteristics are, of course, related to hardenability and heat-treatment although in different respects. The properties of the National Emergency steels are, in many cases, so desirable that their use will grow rather than decrease as normal industrial conditions are reestablished. Their properties frequently are superior to those of the S.A.E. steels which they replaced, at least temporarily, and properties at least as good as those that have been secured with other steels can be produced by treating them properly.

<sup>22</sup> See, for example, M. A. Grossman, *Trans. A.I.M.E.*, **150**, 1942, 227–253; and J. Field, *Metal Progress*, **43**, 1943, 402–405.

<sup>23</sup> See, however, the series of papers in *Metal Progress*, **43**, 1943, 77–90.

*Cast Steels*

## CARBON-STEEL CASTINGS

Castings, which contain those elements that are usually present in steel, in proportions no greater than found in ordinary steels, are termed carbon-steel castings to differentiate them from alloy-steel castings which contain added elements. A carbon-steel casting is further classified, depending upon its carbon content, into *low-carbon* (less than 0.20% carbon), *medium-carbon* (0.20–0.40% carbon), and *high-carbon* (more than 0.40% carbon). A.S.T.M. Standard A95 (High Temperature Service), and Tentative Standards A216-T and A27-T are important among the specifications covering these materials. Any of these types of castings may contain 0.50–1.00% manganese, 0.20–0.75% silicon, and less than 0.05% phosphorus and 0.06% sulfur.

By far the greatest number and tonnage of steel castings are of the medium-carbon classification. Mechanical properties will vary with the carbon range, and may fall within the limits shown in Table XXXV for normalized castings.

TABLE XXXV STRENGTH PROPERTIES OF CARBON-STEEL CASTINGS IN THE NORMALIZED CONDITION

	LOW-CARBON	MEDIUM-CARBON	HIGH-CARBON
Tensile strength, psi	42,000–70,000	60,000–80,000	70,000–120,000
Yield point, psi	20,000–38,000	30,000–40,000	35,000–75,000
Elongation, % in 2 in.	35–22	30–20	25– 3
Reduction in area, %	64–30	40–30	40– 2
Brinell hardness (10 mm–3000 kg)	90–143	130–325	156–500

It will be noted that, as usual, the higher strengths are accompanied by the poorer ductilities.

## HEAT-TREATMENT OF CARBON-STEEL CASTINGS

Steel castings cool rather slowly in the sand molds in which they are usually made, unless chills are used. Because of this, the austenite grains which are formed first will be relatively coarse and dendritic (Fig. 468a),

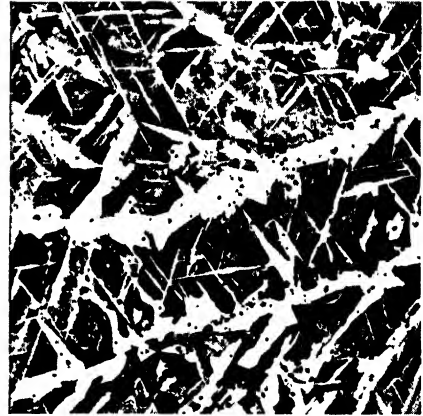
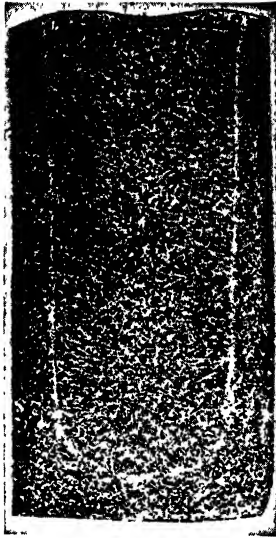


FIGURE 468. Metallographic structure of a cast steel containing about 0.40% carbon. Etched with nital.

- a.* (Left) Macroetched experimental ingot.  $\times 1$ , illustrating dendritic structure. (Photograph by A. J. Calpaxis.)  
*b.* (Upper right) As cast (*Widmannstaetten* type of structure.)  $\times 100$ .  
*c.* (Lower right) Normalized.  $\times 100$ .

and their influence upon the structure will be retained even after the austenite has transformed to pearlite and the casting has cooled to room temperature. These large grains can be seen readily, outlined by white ferrite, in the photomicrograph shown in Fig. 468*b*. Because of this large grain size, these so-called green castings generally have an undesirable combination of a relatively low strength, low ductility, and low toughness which makes them comparatively poor for engineering purposes. Since most cast steels are hypoeutectoid, there is a separation of ferrite from the very coarse-grained austenite, as the steel cools through the critical range.<sup>24</sup> In fine-grained steel, this ferrite would occur almost entirely at the grain boundaries. However, in these coarse-grained castings, the ferrite will separate both at the grain boundaries and along certain crystallographic planes of the austenite matrix, giving a characteristic geometrical structural pattern of ferrite within the pearlitic areas. This also may be seen in Fig. 468*b* and is called a *Widmannstaetten* structure after its discoverer

<sup>24</sup> This subject is well discussed by J. R. Vilella, *Mechanical Eng.*, April 1940, 293-307.

who first found it in meteorites. Similar, although not quite so pronounced, effects are found in many other alloy systems after proper heat-treatment,<sup>24a</sup> and several examples have been given earlier in the text.

Because steel undergoes an allotropic change on heating through  $A_3$ , this particular Widmannstaetten structure can be eliminated by normalizing, along with its deleterious effects. During this treatment, the ferrite will redissolve in the now fine-grained austenite. This, when cooled, will give the normal structure of small grains of pearlite surrounded by ferrite which has separated at the austenite grain boundaries in the manner shown schematically in Fig. 223. This structure is shown in Fig. 468c. The size of the pearlite patches or colonies, which is determined to some extent by the size of the austenitic grains at the heat-treating temperature, will depend upon the temperature of normalizing; and the fineness of the lamellae of the pearlite will be determined largely by the rate at which the casting is cooled after heat-treatment. It is this fine-grained structure which gives cast steel the combination of strength, ductility, and toughness for which it is noted.

Like other steels having similar carbon contents, most cast steels are readily machined and welded, under the proper conditions.

In addition to its uses for crushing, grinding and excavating machinery, which involve wear resistance and will, therefore, be discussed in Chap. XVII, cast steel finds a multitude of other uses, only a few of which can be mentioned here. Cross members, frames and housings in automobiles, trucks and railroad locomotives and cars, armature shafts and bases, flywheels, levers and frames, cylinder blocks and heads, pistons, in which the high strength of cast steel enables it to be cast in relatively thin light-weight sections and thus to compete favorably with the light alloy pistons, anvils, dies, crankshafts, crossheads, high pressure fittings, railroad car wheels, rolling-mill rolls, and roll couplings are some of the applications for which it is used widely. In many respects heat-treated steel castings are excellent engineering materials, and are used as much as structural materials, for their combination of strength and toughness, as they are for their wear resistance.

#### LOW-ALLOY CAST STEELS

For many applications alloying elements are added to cast steels to increase their strength and toughness, and to give them better wear-resist-

<sup>24a</sup> See the series of papers by R. F. Mehl and coworkers starting *Trans. A.I.M.E.*, **93**, 1931, 78-110; also C. H. Mathewson and D. W. Smith, *Trans. A.I.M.E.*, **99**, 1932, 264-271; and N. T. Belajew, *Journ. Inst. Met.*, London, **12**, 1914, 46.

ing properties. In addition to a carbon content of 0.10–1.00%, these low-alloy cast steels may contain one or more of the following alloying elements, usually in the amounts shown:

---

Nickel	0.25–5.00%	Silicon	0.20–2.75%
Manganese	0.50–3.00%	Vanadium	0.10–0.65%
Chromium	0.35–6.50%	Tungsten	0.75–1.50%
Molybdenum	0.20–1.00%	Copper	0.15–2.75%

---

With carefully made low-alloy steel castings tensile strengths as high as 200,000 psi have been secured after a suitable heat-treatment.

Steel castings sometimes are carburized or nitrided when they are to be used as bearing surfaces or when a hard surface is necessary for other reasons. Preferably such hard surfaces should be accompanied by a tough and reasonably hard core. For carburizing, a 0.15% carbon alloy containing either 3.50% nickel, or 1.75% nickel and 0.25% molybdenum generally is used. The composition preferred for nitriding contains 0.15–0.25% carbon, 2.50–3.00% chromium, 0.20–0.25% vanadium, 0.40–0.55% molybdenum. This will develop a surface hardness of 850–900 Brinell after 45 hr nitriding at 950 F (500 C).

All of the low-alloy cast steels can be welded if the proper technique and welding rod are used, although the operation is by no means simple. Careful preheating, or heat-treatment of the entire casting after welding, is frequently necessary to avoid brittleness. In general, the same difficulties arise in the welding of a casting as would arise in the welding of any low-alloy steel analysis, largely resulting from the effects of the alloying elements upon the hardenability of the steel.

Alloy-steel castings other than the heat- and corrosion-resisting types, are specified in A.S.T.M. Standard A157 (High Temperature), and Tentative Standards A148-T (Structural), A217-T.

#### NICKEL CAST STEELS

The addition of nickel to a steel casting increases the strength and toughness markedly by producing a fine-grained ferrite and a fine pearlitic structure. Tensile strengths of a 2.50% nickel alloy will average 70,000–85,000 psi, with a yield point of 50,000 psi, an elongation of 34% in 2 in., and a reduction in area of 64%. In addition, the casting will have the high Izod impact value of 30–70 ft-lb.

A considerable tonnage of steel castings is made of a nickel-chromium analysis containing 0.50–2.00% chromium and preferably having the nickel and the chromium in the ratio of 2.5:1. The addition of chromium increases the tensile strength and yield point, gives a greater hardness penetration on heat-treatment, and increases the wear resistance, ductility, and impact strength over that of the alloy containing nickel alone. The castings are quenched and tempered usually.

The hardening tendencies of nickel cast steels also can be increased by the addition of 0.20–0.60% molybdenum. These analyses air-harden and, therefore, must be tempered after normalizing.

The addition of vanadium to nickel cast steels increases the elongation, reduction in area, endurance, and the impact values. It is particularly desirable for highly stressed castings of heavy section, especially in the lower carbon range where a maximum resistance to impact is desired.

#### MEDIUM-MANGANESE CAST STEELS

The medium-manganese cast steels are very useful and possess much greater toughness and resistance to shock than the plain carbon varieties. The mechanical properties are determined to a large extent by the carbon content, a decrease in carbon increasing the toughness but at the expense of strength. The mechanical properties of these analyses also can be increased by quenching and tempering.

The addition of nickel to the manganese cast steels tends to increase their impact resistance and to decrease their temper brittleness but the resultant alloys will air-harden.

Chromium increases the strength and abrasion resistance of the manganese steel castings, although the impact properties of the resulting alloy are only fair.

The addition of molybdenum increases the tensile strength, yield strength and creep resistance at high temperatures of the manganese analyses. The alloys will have a fine-grain structure but also will be air-hardening.

The use of vanadium results in a fine-grain size, and increases the yield and impact strengths.

Usually these analyses are used in a quenched and drawn, or normalized and drawn condition for castings subject to severe shock, such as locomotive and railroad castings and castings for heavy machinery. For high-tensile railway castings, the addition of titanium has proved to be beneficial, giving a fine-grain structure with increased yield strength, ductility, and impact values.

GENERAL EFFECTS OF CHROMIUM AND MOLYBDENUM IN STEEL  
CASTINGS

Chromium increases the depth of hardness penetration after quenching, and usually is used in conjunction with other alloy additions. It also tends to refine the grain size and increase the hardness of the casting. The addition of chromium on the higher side of the limits shown above imparts excellent wear resistance but with accompanying brittleness. However, this can be overcome to some extent by the use of 0.10–0.15% vanadium with 0.30–0.40% molybdenum in conjunction with it.

Molybdenum is added largely in combination with other elements to give air-hardening characteristics to castings that are not suitable for quenching. Both *molybdenum cast steels* (0.30–0.40% carbon, 0.30–0.50% molybdenum) and *molybdenum-vanadium cast steels* (0.30–0.50% carbon, 0.30% molybdenum, 0.10% vanadium) have been used successfully for making centrifugally cast guns, for example. After suitable heat-treatment, tensile strengths of 95,000–100,000 psi are secured, with proportional limits of 65,000–75,000 psi, elongations of 25–20%, and reductions in area of 60–55%, combined with Charpy impact values of 35–45 ft-lb.

### *Cast Irons*

PROPERTIES OF GRAY CAST IRON

Seven classes of gray iron castings, differing in their minimum tensile strength requirements, are covered by A.S.T.M. Specification A48:

CLASS NO.	PSI
20	20,000
25	25,000
30	30,000
35	35,000
40	40,000
50	50,000
60	60,000

In general, the lower carbon irons, containing the proper amounts of silicon, are the higher strength varieties, and the higher carbon irons with normal silicon contents are soft and have low strengths. This results from

the weakening effects of the graphite which would be produced in the latter alloys. The mechanical properties desired, the structure, and the section must all be considered in determining the proper carbon-silicon ratio to use.

Gray cast irons have an effective modulus of elasticity of 12,000,000–18,000,000 psi, and may approach 30,000,000 psi in certain special and alloyed castings. They have no well-defined elastic limit or yield point, but under some conditions can sustain static loads of up to 80% of their tensile strength without failure. *When properly made under close control*, they are a very important and relatively inexpensive engineering material having tensile strengths and other mechanical properties which are generally much better than usually is realized.

The fatigue endurance properties of cast iron vary nearly linearly with the tensile strength, the endurance limit being about one half the tensile strength. In particular the effect of notches is much less with them than with other materials. They have a high damping capacity, and hence derive their greatest value from insensitiveness to notch effects rather than to any inherently high fatigue strength. Their impact strength is relatively low, although this varies greatly with the analysis and treatment.

#### HIGH-TEST CAST IRON

The name high-test cast iron has been given to ordinary gray iron in which tensile strengths of 38,000–50,000 psi are produced consistently by careful control of the nature of the charge and the melting cycle. These two factors enable the total carbon to be kept low and the graphite particles to be kept small and uniformly distributed. These are about the highest strength cast irons that can be produced without using alloying elements or considerable metallurgical control. In arbitration test bars, the high-test irons will have a transverse strength of 4200–5600 lb with a deflection of 0.15–0.20 in., and a Brinell hardness of 200–240. This grade is used very widely for medium and heavy castings where strength and wear resistance are required, because it can be made easily in any foundry with reasonable care.

*Automotive gray iron* castings, both plain and alloyed, are covered by A.S.T.M. Tentative Standard A159-T and by S.A.E. Nos. 110–112 for plain gray iron and Nos. 120–127 for alloy cast iron.

#### HIGH-STRENGTH CAST IRON

To produce various ranges of tensile strength in alloy cast iron sections from  $\frac{1}{2}$ –4 in. thick, proper control of the nickel and silicon is required, as



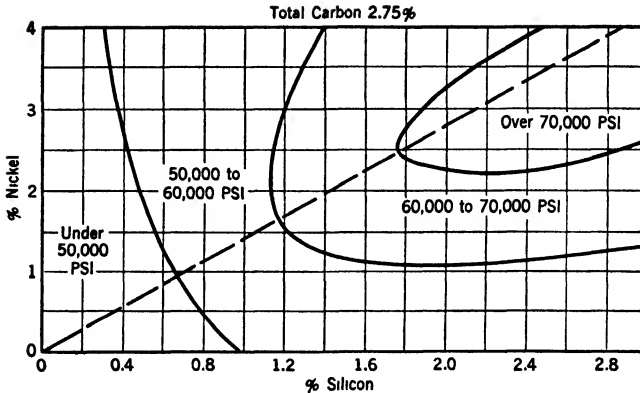


FIGURE 469. Influence of nickel and silicon content on the properties of a high-strength cast iron containing about 2.75% carbon. (Courtesy The International Nickel Company, Inc.)

illustrated in Fig. 469 for an alloy containing 2.75% carbon. Alloys of this type are sold under the trade name of *Ni-Tensyl* iron, and usually analyze within the limits:

% SI	% T.C.	% MN	% NI	% CR	% MO
1.2-2.8	2.5-3.2	0.5-0.9	1.0-4.0	0-0.05	0-0.05

In addition to the tensile strength of 50,000-75,000 psi, specimens of this alloy will have a transverse strength of 4500-8000 lb with a deflection of 0.11-0.25 in., and a compressive strength of 165,000-190,000 psi. The Brinell hardness will range 220-320, and the fatigue endurance limit 50-57% of the tensile strength.

#### HEAT-TREATED CAST IRONS

Alloys containing 0.30-0.90% molybdenum, 0.30-0.40% chromium, and low carbon, will be very tough and hard and can be made to specifications calling for tensile strengths of 60,000-80,000 psi. By heat-treatment this strength can be increased further to as high as 75,000-100,000 psi.

In general, these compositions give dense, gray, finely pearlitic structures in the "as-cast" condition in which they are used most often. The customary heat-treatment, if greater strength is required, is a gradual heating to 1500-1550 F (815-845 C), followed by oil quenching and imme-

diate tempering to the strength, hardness, or toughness desired. In the oil-quenched condition, Brinell hardnesses of 350–500 may be secured.

#### MEEHANITE

Cast irons in which the molten metal has been treated with calcium silicide, usually in the ladle, are sold under the trade name *Meehanite*. Any of the common methods of melting may be employed but the composition usually is adjusted so the fracture would be white if no treatment were used. The addition of the graphitizer, calcium silicide, produces a fine graphitic structure, giving an alloy which has excellent mechanical properties. It is more an alternate, controllable method for producing a given microstructure and set of properties than an individual alloy, since very little calcium silicide remains in the alloy after solidification.

As mentioned in Chap. V, similar results may be secured by superheating the molten iron; or other graphitizing agents, such as ferrosilicon, may be used to treat the iron in the ladle. The inoculation even may be achieved by casting metal of the proper analysis into heated molds as in the *Lang process*. However, all of these are merely means of securing a metallographic structure having the minimum amount of graphite and that distributed in as fine a manner as possible.<sup>25</sup> They depend on utilizing a “tapping” composition, usually of low-silicon and moderately low-carbon content, viz., 2.50–3.00% carbon, which normally would be white if cast, and then graphitizing it in a controlled manner in the ladle so the resultant casting is both gray and machinable. These cast irons are produced from electric furnaces, air furnaces, rotary furnaces, and cupolas and it is only by these methods of careful control that modern high-strength cast irons can be made on a production basis. *High-test cast iron can be made successfully only in a high-test foundry.*

#### MALLEABLE CAST IRON

Because of its structure (Fig. 471a), which is essentially a mixture of ferrite and temper carbon, or nodular graphite, the combination of toughness, corrosion resistance, and machinability in malleable cast iron is surprisingly good. For this reason, it is used widely for applications requiring resistance to shock, such as plows, tractors, harrows, cultivators, rakes, and similar agricultural implements, for many automobile and railroad parts, for hardware and plumbing supplies, for small tools and toys, and

<sup>25</sup> The general subject of inoculation of gray cast iron has been very well discussed by J. T. Eash, *Trans. A.F.A.*, June 1942, 887.

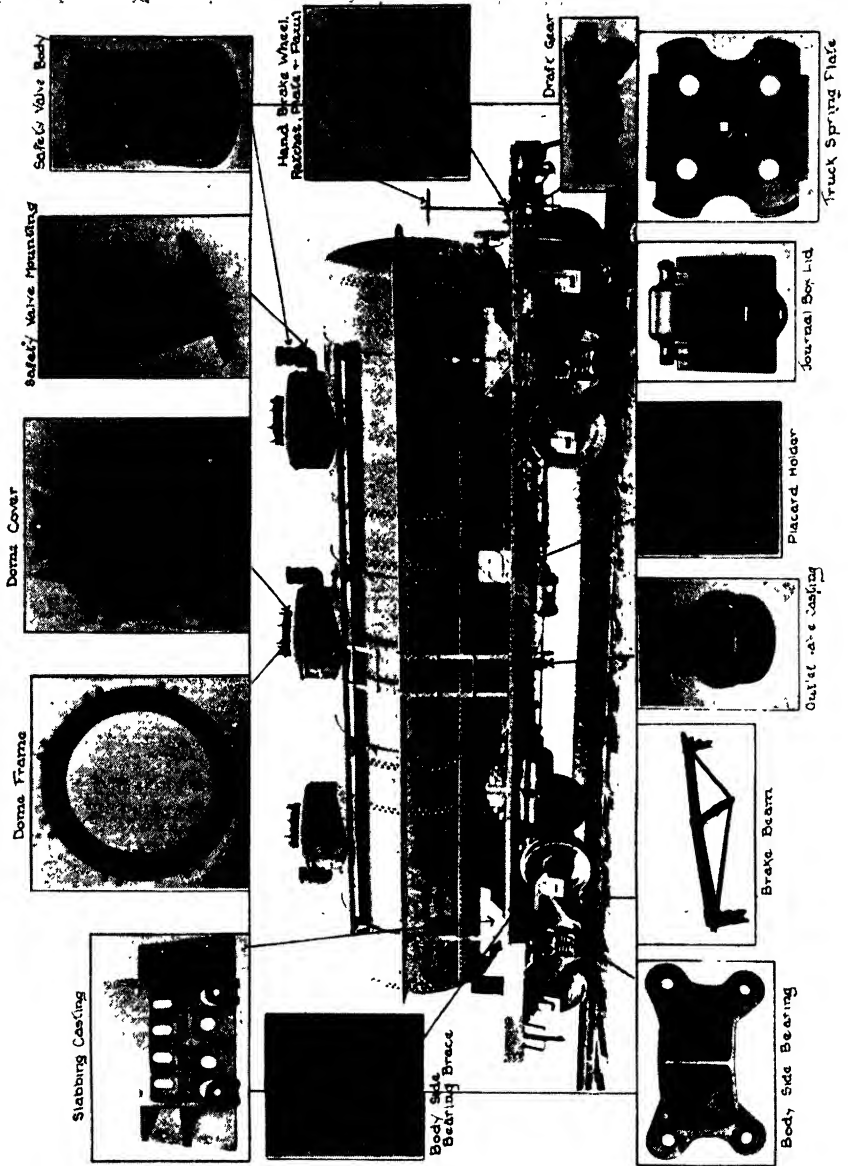


FIGURE 470. Some malleable iron castings used on a modern tank car and their approximate location. (From *Cast Metals Handbook*, 1940 ed., courtesy American Foundrymen's Association.)

for many types of marine equipment. Some typical places where malleable iron castings are used on a modern tank car are illustrated in Fig. 470.

Compositions usually are selected to meet one of the two grades covered

by the S.A.E. Standards and by A.S.T.M. Standard A47. Typical analyses of castings of these grades are shown in Table XXXVI.

TABLE XXXVI ANALYSES AND STRENGTH PROPERTIES TYPICAL OF S.A.E. GRADES OF MALLEABLE IRON

	S.A.E. GRADE 35018	S.A.E. GRADE 32510
<b>WHITE CAST IRON</b>		
%C	1.75-2.30	2.25-2.70
%Si	0.85-1.20	0.80-1.10
%Mn	0.40 (max)	0.40 (max)
%P	0.20 (max)	0.20 (max)
%S	0.12 (max)	0.07-0.15
<b>MALLEABLE IRON</b>		
%Temper C	1.80 (max)	2.20 (max)
%Si	1.20 (max)	1.10 (max)
%Mn	0.40 (max)	0.40 (max)
%P	0.20 (max)	0.20 (max)
%S	0.12 (max)	0.12 (max)
<b>STRENGTH PROPERTIES OF MALLEABLE IRON (MIN)</b>		
Tensile strength, psi	53,000	50,000
Yield point, psi	35,000	32,500
Elongation, % in 2 in.	18	10
Brinell hardness (10 mm-3000 kg)	110-135	110-135

The strength of the finished casting is affected almost as much by the foundry practice as by the chemical composition. Minimum values for the mechanical properties of the two grades of malleable iron also are shown in Table XXXVI. Considerable variation in these values is entirely possible.

#### PEARLITIC MALLEABLE CAST IRON

In order to secure higher strengths in malleable castings than is possible with the ferritic type, some of the carbon is left in the combined form in the matrix, either by incompletely graphitizing the alloy or else by recombining some of the temper carbon with the iron by proper heat-treatment.<sup>26</sup> The former is the more common method, and the desired structure most frequently is produced by cooling directly to room temperature from the high graphitizing temperature range, about 1700 F (925 C).

The metallographic structure of one of the commercial types has nodular temper carbon particles in a matrix which may be either lamellar (pearlitic),

<sup>26</sup> See C. H. Lorig, *A.S.T.M. Bulletin No. 105, 1940, 29-35.*

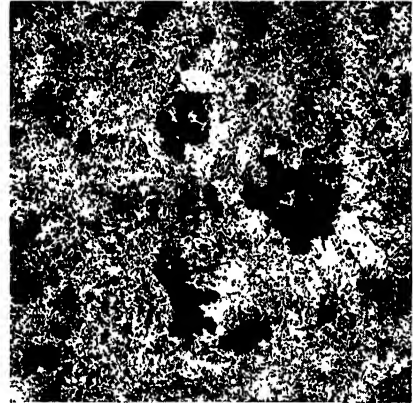
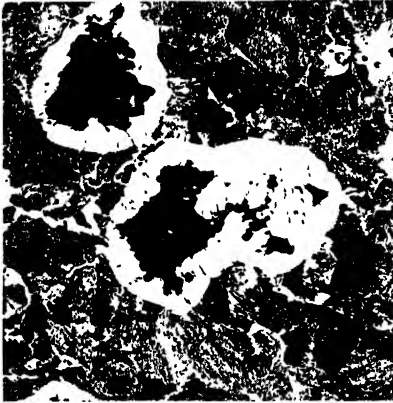
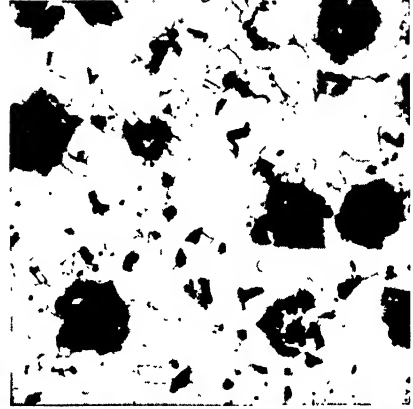
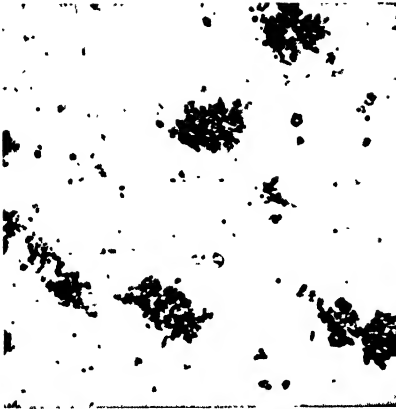


FIGURE 471. Metallographic structures of various types of malleable cast irons. Etched with 4% nital.

a. (Top) Ferritic, unetched (left) and etched (right).  $\times 100$ .

b. (Middle left) Pearlitic.  $\times 100$ .

c. (Middle right) Sorbitic (i.e., quenched and tempered).  $\times 100$ .

d. (Bottom) Martensitic (i.e., quenched).  $\times 1000$ .

(Photomicrographs b, c, d courtesy Dr. H. A. Schwartz, National Malleable and Steel Castings Company.)

granular (spheroidized or sorbitic), or even martensitic, depending on the heat-treatment used (Fig. 471). Some of the names under which pearlitic malleable castings are sold commercially are: *Z-Metal*, *Gunite-K*, *Mallix*, *Belmalloy*, *Perduro*, and certain types of *Meehanite*.

These pearlitic alloys are stronger, less machinable, and sometimes less shock resistant than ordinary malleable cast iron. Tensile strengths of 70,000–90,000 psi can be secured readily, with yield points of 48,000–60,000 psi, and elongations of 18–8% depending upon the strength. Brinell hardnesses above 300 can be produced, but about 200 is the reasonable maximum for machinability. Both the strength and hardness can be increased by suitable heat-treatment, i.e., quenching and tempering, after malleabilizing.

With proper additions of chromium and aluminum, an alloy can be produced which can be nitrided to give a high surface hardness.

### *Light Metal Alloys*

#### DURALUMIN-TYPE ALLOYS

Two wrought-aluminum alloys of the duralumin type are used in this country primarily because of their high strength. Additional alloys with this characteristic can be expected to be available in the near future. These two, which are appreciably stronger than the aluminum alloys discussed in Chap. XIII, are Alcoa 17S (and its modification A17S used for rivets) and 24S, the nominal chemical compositions of which are:

ALCOA NO.	% CU	% MN	% MG
17S	4.0	0.5	0.5
A17S	2.5	—	0.3
24S	4.5	0.6	1.5

Aluminum and its normal impurities, chiefly iron and silicon, comprise the remainder of each alloy.

The original Duralumin alloy, 17S, is covered by S.A.E. No. 26, and is alloy CM21 in A.S.T.M. Tentative Standards B211-T (Bars, Rods, Wire) and B210-T (Tubing). This alloy still is used widely and is produced regularly in all the usual structural forms, although for some applications, such as in the aircraft industry and for sheet and plate, it has been replaced by 24S and other more recently developed alloys, such as 75S, which have even better properties than 24S under certain conditions. In the aircraft industry the highest tensile and yield strengths are desired because of the savings in weight they permit with consequent improve-

ments in performance, but in other types of structures even the mechanical properties of 24S are frequently not enough higher than those of the 17S alloy to justify a higher cost. S.A.E. No. 24, and A.S.T.M. Tentative Standards 209-T, 210-T, and 211-T all cover 24S (alloy CG21).

Typical mechanical properties for the soft (-O), and fully heat-treated and age-hardened (-T4) tempers of both of the alloys containing copper and magnesium will generally fall within the ranges given in Table XXXVII. However, the values for the 17S alloy usually will be near the lower limit and those of the 24S alloy near the upper limit, a difference which is extremely significant in the aircraft industry, where the usual engineering factors of safety can have little significance. In addition 24S sheet and plate are available strain-hardened after heat-treatment (-T36), with the general properties shown.

TABLE XXXVII STRENGTH PROPERTIES TYPICAL OF THE DURALUMIN-TYPE ALLOYS

ALLOY	TEMPER	TENSILE STRENGTH, PSI	YIELD STRENGTH, PSI	ELON- GATION, % IN 2 IN.	BRINELL HARDNESS (10 MM- 500 KG)
17S or 24S	-O—Soft (recrystallized)	26,000	10,000	21	42- 45
17S-24S	-T4—Fully heat-treated	62,000- 68,000	40,000- 46,000	22-19	100-104
24S	-T36—Strain-hardened after heat-treatment	65,000- 73,000	50,000- 57,000	13	115-120

Since the alloys age-harden at room temperature, attaining maximum hardness after about 4 days, and 90% of this value after 1 day, there is but one heat-treated temper. Elevated temperature aging treatments have been used, however, to improve the properties of 24S somewhat. Cold-working after heat-treatment increases the yield strength markedly, as indicated, but has little or no effect on the corrosion resistance. Consequently, the -T36 temper is advantageous when it is possible to utilize it.

Both alloys also are made in the *Alclad* form in which, for the commonly used thicknesses, their tensile and yield strengths are approximately 10% lower than for the uncoated alloys. The use of this form is recommended if extended exposure to the weather is involved.

In the soft temper, both of the alloys will withstand severe forming

operations; but in the heat-treated condition considerably greater care is required and considerably less working is possible.

The modified composition, A17S, will develop tensile strengths of 22,000 psi annealed and 43,000 psi in the heat-treated temper, with yield strengths of 8000 psi and 24,000 psi respectively. Its elongation will be about 24% in either case, and when used for rivets it can be driven in the fully heat-treated and aged temper.

An interesting development in the riveting of these alloys is the explosive rivet described earlier (Fig. 345). These are particularly suitable for "blind" riveting where a backing tool cannot be used. The force of the explosion, released by applying heat to the rivet head, sets the rivet firmly in position and speeds up the riveting operation greatly.

With suitable techniques, 17S and 24S alloys can be welded by either spot-, torch-, or arc-welding methods. Spot welding is used largely for assembly of aircraft parts, especially for Alclad type sheet. Torch- and arc-welding methods are not employed because the heating incident to welding alters the mechanical properties appreciably and has an adverse effect on the resistance to corrosion.

The preferred solution treatment is a soak at 930–950 F (500–510 C) for 17S and 915–930 F (490–500 C) for 24S, followed by a rapid water quench in either case. After quenching, aging can be delayed for at least a week by storing at 0 F (–18 C), or for several hours by storing in an ordinary refrigerator. Complete annealing can be effected by cooling slowly in air from 640–670 F (340–355 C), if the alloy was originally cold-formed in the soft condition, or from 750–800 F (400–425 C) if originally in the heat-treated condition,

Metallographic structures typical of the two alloys in both the annealed and heat-treated conditions are shown in Figs. 472 and 473. The fine precipitate will consist, principally, of the  $\theta(\text{CuAl}_2)$  and  $\text{Mg}_2\text{Si}$  constituents but the particles are difficult to distinguish.

#### HIDUMINIUM ALLOY R.R. 77

The aluminum alloy known as Hiduminium R.R. 77, and having the nominal composition 1.5–3.0% copper, 4.0–6.0% zinc, 2.0–4.0% magnesium, remainder aluminum, has been available commercially for some time in England.<sup>27</sup> Its chief use is for extrusions although it can be cold-formed with special precautions.

<sup>27</sup> The Hiduminium alloys are fully described in *Hiduminium Technical Data*, High Duty Alloys, Ltd., 1941, Slough.





FIGURE 472. Metallographic structures typical of aluminum alloy, 17S (4% Cu — 0.5% Mn — 0.5% Mg — rem. Al), sheet. Etched with Keller's reagent.  $\times 100$ .

a. (Left) Annealed: -O temper.

b. (Right) Fully heat-treated and age-hardened: -T4 temper.

(Photomicrographs courtesy Aluminum Research Laboratories.)

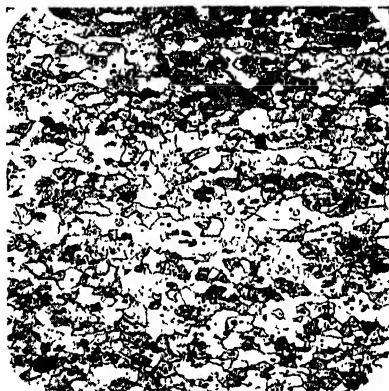
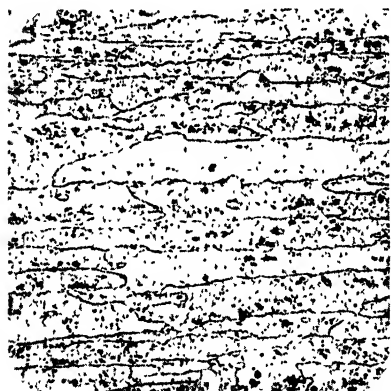


FIGURE 473. Metallographic structures typical of aluminum alloy 24S (4.5% Cu — 0.6% Mn — 1.5% Mg — rem. Al), sheet.  $\times 100$ .

a. (Left) Annealed: -O temper. Etched with Bossert's reagent.

b. (Right) Fully heat-treated and age-hardened: -T4 temper. Etched with Keller's reagent.

(Photomicrographs courtesy Aluminum Research Laboratories.)

The outstanding characteristic of the alloy is its mechanical properties, typical values of which are given in Table XXXVIII. The recommended solution treatment is 2–3 hr at 850–870 F (455–465 C). Natural aging is carried out at room temperature, and artificial aging is carried out for 15–20 hr at 265–285 F (130–140 C) followed by an air cool.

The excellent properties of aluminum-magnesium-zinc alloys have been known for several years but their corrosion resistance has been so poor that they have had little commercial value. When this problem finally was

TABLE XXXVIII STRENGTH PROPERTIES TYPICAL OF HIDUMINIUM R.R. 77

TEMPER	TENSILE STRENGTH, PSI	YIELD STRENGTH (0.1% ELONGATION), PSI	ELONGATION, % IN 2 IN.	BRINELL HARDNESS (10 MM- 500 KG)
Annealed	27,000-31,000	9,000-18,000	20-14	45-65
Solution treated and naturally aged	65,000-71,000	40,000-47,000	21-16	130-140
Solution treated and artificially aged	74,000-85,000	63,000-73,000	16-10	160-180

solved and the R.R. 77 alloy became commercially available, however, it was found that it tended to be susceptible to stress corrosion cracking and hence found few applications for which it was satisfactory. Whether or not this difficulty has been overcome as yet is not known.

#### ALCOA 75S ALLOY

Army-Navy Aeronautical Specifications AN-A-9, AN-A-10, and AN-A-11 cover an alloy designated commercially as Alcoa 75S. This alloy is available in the bare form as extrusions and rod and in the Alclad form as sheet and is now included in A.S.T.M. Tentative Standards B209-T and B211-T as alloy ZG42. Alloy 75S contains 1.2-2.0% copper, 5.1-6.1% zinc, 2.1-2.9% magnesium, and 0.15-0.40% chromium with the remainder aluminum and normal impurities. The properties specified for it are 35,000 psi tensile strength (max), with 10% (min) elongation in 2 in. in the annealed condition, and 77,000-90,000 psi tensile strength, 60,000-80,000 psi yield strength with 7-10% elongation in 2 in. in the fully heat-treated condition.

#### ALUMINUM FORGING ALLOYS

In addition to the alloys which already have been discussed in Chap. XV, viz., 18S and 32S, and which are used primarily for forgings required to retain their mechanical properties at elevated temperatures, and to 17S-T4 and 53S-T6 which have a greater resistance to severely corrosive conditions than the other alloys, three aluminum forging alloys are in common use today. These contain, in addition to aluminum:

ALCOA NO.	% CU	% SI	% MN	% MG	% CR
14S	4.4	0.8	0.8	0.4	—
25S	4.5	0.8	0.8	—	—
A51S	—	1.0	—	0.6	0.25

Alloy 14S is covered by A.S.T.M. Tentative Standard B211-T (alloy CS41) although, primarily, this is a bar, rod, and wire specification.

The mechanical properties of the three alloys in the heat-treated condition are considerably different, typical values being shown in Table XXXIX.

TABLE XXXIX STRENGTH PROPERTIES OF SOME COMMON ALUMINUM FORGING ALLOYS

	14S-T6	25S-T6	A51S-T6
Tensile strength, psi	70,000	57,000	47,000
Yield strength, psi	60,000	35,000	40,000
Elongation, % in 2 in.	14	18	20
Brinell hardness (10 mm-500 kg)	135	100	90
Fatigue endurance limit, psi	18,000	15,000	10,500

Because of its excellent combination of high mechanical properties and corrosion resistance in the heat-treated condition 14S is the most important of the alloys although it is not forged quite so easily as 25S or A51S. Alloy 25S is the standard alloy for forged aircraft propellers and all three alloys are used extensively for aircraft structural fittings and engine parts. The S.A.E. Standards No. 27 and 280 cover the 25S and A51S alloys, respectively. All three are also covered by Federal Specification QQ-A-367 and by the S.A.E. Aeronautical Material Specifications (AMS).

Microstructures typical of 14S-T6 and A51S-T6 are shown in Fig. 474.

#### HIGH-STRENGTH ALUMINUM CASTING ALLOYS

The aluminum casting alloys most widely used because of their good mechanical properties contain one or more of the elements copper, magnesium, or silicon.

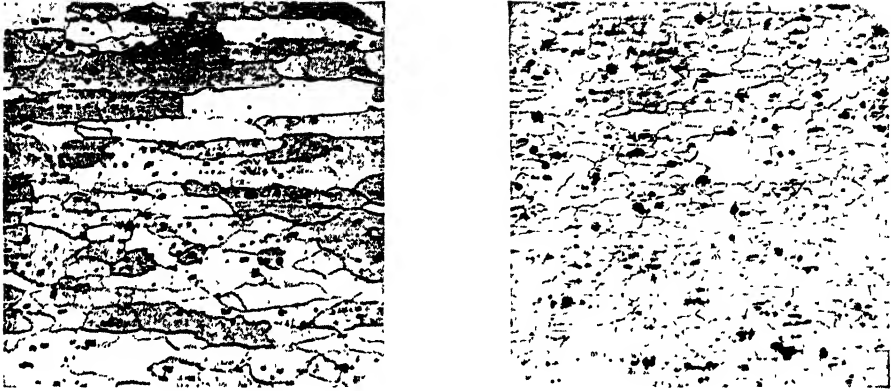


FIGURE 474. Metallographic structures typical of two aluminum forging alloys in the fully heat-treated and age-hardened condition.  $\times 100$ .

a. 14S-T6 (4.4% Cu — 0.8% Si — 0.8% Mn — 0.4% Mg — rem. Al). Etched with Keller's reagent.

b. A51S-T6 (1% Si — 0.6% Mg — 0.25% Cr — rem. Al). Etched with  $\frac{1}{2}\%$  HF. (Photomicrographs courtesy Aluminum Research Laboratories.)

Alloy 25S would have a structure similar to that of 14S.

#### ALUMINUM-COPPER CASTING ALLOYS

The three most important aluminum-copper casting alloys contain, nominally, in addition to aluminum and normal impurities:

ALCOA NO.	% CU	% SI	% ZN
195	4.5	0.8	—
112	7.0	—	1.7
212	8.0	1.2	—

These were the original commercially important aluminum casting alloys, and they still are used for more than half of the castings made. They are covered by S.A.E. Standards No. 38, 33, and 36, respectively, as well as by A.S.T.M. Tentative Standards B179-T, for ingots, and B26-T (alloys C1, CS21 and CS22), for sand castings. For permanent mold castings *B195*, containing 4.5% copper, 2.5% silicon, is used in preference to 195; *C113*, containing 7% copper, 3.5% silicon, in preference to 112; and *113*, containing 7% copper, 2% silicon, 1.7% zinc, instead of 212 because of the better casting characteristics imparted by the higher silicon additions.

The 195 alloy may be given several possible heat-treatments producing thereby the comparatively wide range of mechanical properties: tensile strength 30,000–40,000 psi, yield strength (0.2% offset) 16,000–31,000 psi, elongation 8.5–2% in 2 in., and Brinell hardness (10 mm–500 kg) 65–100. The casting characteristics of the 4.5% copper alloy are not so good as those of the original 8% copper alloy, (12); but its corrosion resistance, especially after the solution heat-treatment, is better. Castings of the 4.5% copper alloy are used widely in aircraft engines and fuselage fittings for general high-strength structural parts, and for automotive, railway, and marine castings, the particular heat-treatments depending upon the application. In the heat-treated condition the resistance to salt-spray corrosion is comparatively good. The microstructure of this alloy will be essentially the same as that of as-cast Duralumin, 17S, or of 142 alloy (Fig. 458).

The 7–8% copper alloys, 112 and 212, sand cast, will develop tensile strengths of 24,000 psi, with yield strengths (0.2% offset) of 14,000 psi, elongations of 2% in 2 in., and a hardness of Brinell (10 mm–500 kg) 65–70. The variations in composition of alloys 112 and 212 are used chiefly because of their better casting characteristics, in comparison with those of the plain aluminum-copper alloy. They also can utilize a greater percentage of scrap in their production than the 195 alloy can. Typical uses for these alloys are in the automotive industry for general-purpose castings such as transmission housings, various miscellaneous fittings, and for various parts of household and office equipment not subject to extreme stresses or impact.

The structure of a typical 8% copper alloy is illustrated in Fig. 475. The major constituents are the eutectic, between  $\theta(\text{CuAl}_2)$  and the aluminum-rich primary solid solution, and the matrix of aluminum-rich primary solid solution. Some precipitated particles of  $\theta(\text{CuAl}_2)$  also can be seen as well as some dark etching Al-Fe-Si constituent.

#### ALUMINUM-MAGNESIUM ALLOYS

The 10% magnesium casting alloy, 220, is unique among the aluminum alloys in having to be cast by the teachings ordinarily used only for magnesium-base alloys. Most foundries cannot, therefore, handle it. The alloy, which is covered by S.A.E. Standard No. 324 as well as by the A.S.T.M. Standard (alloy G3), is of importance largely because it has the highest strength, elongation, and impact resistance of any of the aluminum casting alloys. In addition, it has a low specific gravity and excellent corrosion resistance. The casting characteristics are inferior to those of the 4% copper alloys, however, and the alloy is not recommended for castings that must be leakproof.

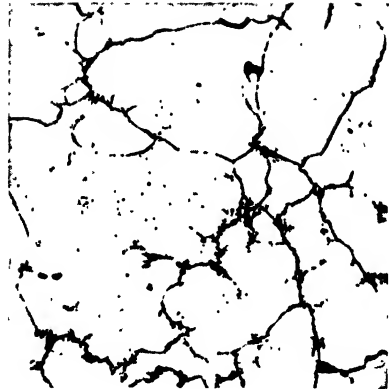


FIGURE 475. (Left) Metallographic structure typical of the aluminum-copper sand-casting alloy, 112 (7% Cu - 1.2% Fe - 2% Si - 1.5% Zn - rem. Al). Etched with Keller's reagent.  $\times 100$ . (Photomicrograph courtesy Aluminum Research Laboratories.)

FIGURE 476. (Right) Metallographic structure typical of the aluminum-magnesium sand-casting alloy, 220-T4 (10% Mg - rem. Al), after heat-treatment. Etched with Keller's reagent.  $\times 100$ . (Photomicrograph courtesy Aluminum Research Laboratories.)

After being given a high-temperature heat-treatment, average tensile strengths of 45,000 psi can be developed by aging, with yield strengths (0.2% offset) of 25,000 psi, elongations of 14% in 2 in., and a hardness of Brinell (10 mm-500 kg) 70-85.

This alloy has been used chiefly in railway-car construction and for such applications as truck frames, electric motor housings, car body fittings, clamshell and dragline bucket fittings, and other miscellaneous castings requiring maximum strength and impact resistance. A photomicrograph typical of the heat-treated structure is shown in Fig. 476. The principal constituents are the precipitated particles of  $\alpha(\text{Al-Mg})$  secondary solid solution in a matrix of an aluminum-rich primary solid solution.

#### ALUMINUM-SILICON CASTING ALLOYS

The 13% silicon alloy, 47, and the heat-treatable 7% silicon, 0.1% magnesium alloy, 356, both have excellent casting characteristics and are used largely for this reason, although the use of the 13% silicon alloy, which is not susceptible to heat-treatment, is decreasing. The 5% silicon alloy, 43, which has been discussed in Chap. XIV, and the 10% silicon alloy, 45, are more popular alloys than 47.

The excellent fluidity and casting characteristics of the aluminum-silicon alloys also make them used widely for welding both wrought and cast prod-

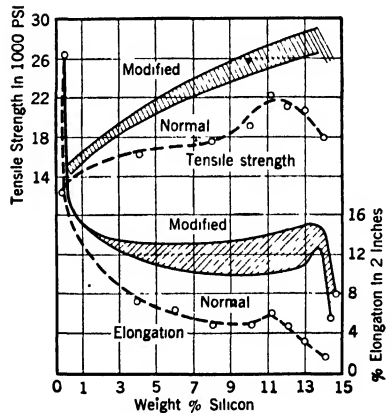
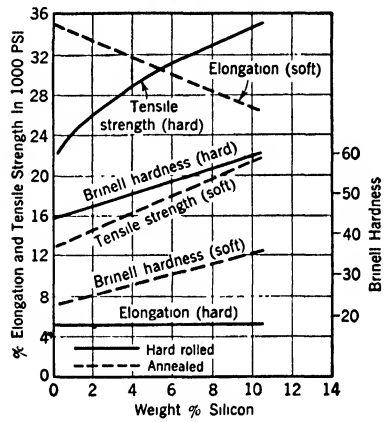
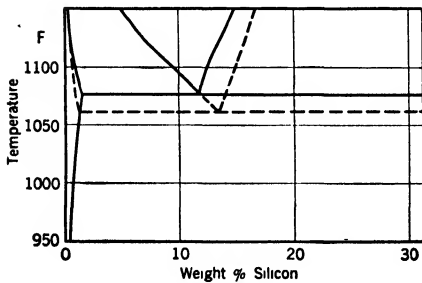
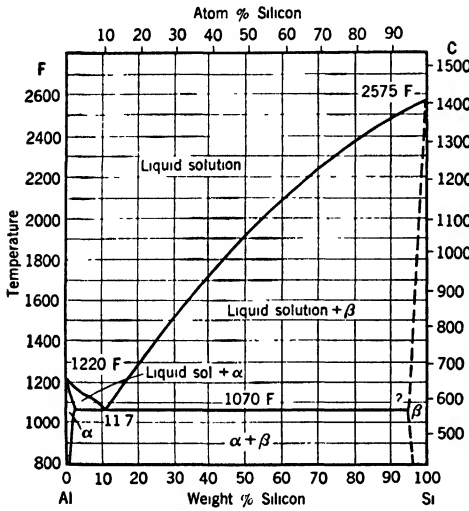
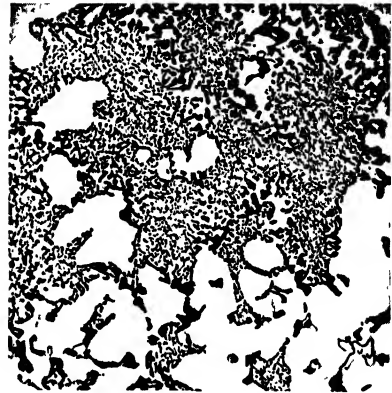


FIGURE 477a. (Top left, right) Metallographic structures typical of the aluminum-silicon casting alloy, 47 (13% Si - rem. Al). Left, normal structure as sand cast. Right, modified structure as chill cast. Etched with  $\frac{1}{2}\%$  HF.  $\times 250$ . (Photomicrographs courtesy Aluminum Research Laboratories.)  
 b. (Bottom left) Aluminum-silicon constitutional diagram (upper) and enlarged diagram of eutectic region (lower) illustrating depression of eutectic temperature and shift in

ucts. The lower silicon alloy, 43, is more popular than 47 for this purpose, however.

The sand-casting alloy, 47, contains slightly more silicon than the eutectic composition (11.7% silicon), and, if cooled in the normal manner, would have a structure similar to that shown in Fig. 477a (left). However, either by cooling the alloy rapidly or by using so-called modifiers such as sodium, the apparent eutectic temperature may be decreased from 1070 F (575 C) to as low as 1040 F (565 C), as shown in Fig. 477b, with a marked change in the structure (Fig. 447a, right), characterized by the absence of large particles of free silicon. This is called the *modified structure*. In this condition, average tensile strengths of 26,000 psi are secured, with yield strengths (0.2% offset) of 11,000 psi, elongations of 8% in 2 in., and hardnesses of Brinell (10 mm–500 kg) 45–60, appreciably better than those secured in the *normal* condition as indicated in Fig. 477d. This alloy, which is covered by A.S.T.M. Tentative Standard B179-T (alloys S5 and S9), for ingots, as well as by S.A.E. No. 37, is used where heat-treating equipment is not available to treat the newer alloys. It makes good pressure-tight castings that have a satisfactory corrosion resistance, strength, and ductility, and are well suited for general purpose castings such as marine and automotive water-jacket and manifold castings. Because of the free silicon, however, difficulties may be encountered in machining. When cast without taking special precautions to produce the modified structure the alloy is coarsely crystalline and quite brittle.

The 356 alloy,<sup>28</sup> when made and heat-treated properly, will develop properties comparable with those of the heat-treated aluminum-copper alloys, and still retain casting characteristics comparable with those of the aluminum-silicon alloys. Depending on the heat-treatment used, average tensile strengths in the range 25,000–35,000 psi can be produced, with yield strengths (0.2% offset) of 20,000–30,000 psi, elongations of 5–2% in 2 in., and a hardness of Brinell (10 mm–500 kg) 55–90. This alloy competes with the heat-treated 4.5% copper alloy, 195, but after the solution treatment will have a better corrosion resistance. In addition, 356 has better casting characteristics than the 4.5% copper alloy, even though its impact resistance will be lower. It is particularly suitable, therefore, for pressure-

<sup>28</sup> See R. S. Archer and L. W. Kempf, *Trans. A.I.M.E.*, **93**, 1931, 448.

---

apparent eutectic composition as a result of "modification." (After M. Hansen; and E. H. Dix, Jr. and A. C. Heath, Jr., *Trans. A.I.M.E.*, **78**, 1928, 164.)

c. (Middle right) Mechanical properties of aluminum-silicon sheet alloys.

d. (Bottom right) Tensile properties as determined from ½-in. diameter sand-cast test bars. (Fig. 477c and d after *Metals Handbook*, A.S.M.; and R. S. Archer and L. W. Kempf, *Trans. A.I.M.E.*, **73**, 1926, 581.)





FIGURE 478. Metallographic structure typical of the aluminum-magnesium-silicon sand-casting alloy, 356-T6 (0.3% Mg - 7% Si - rem. Al), after heat-treatment. Etched with  $\frac{1}{2}\%$  HF.  $\times 100$ .

(Photomicrograph courtesy Aluminum Research Laboratories.)

tight castings, both sand and permanent mold, such as for Diesel engine crank-cases and engine bases, various pneumatic tools and air compressor parts, as well as, in aircraft, for small engine parts and structural fittings or for castings of intricate design.

A metallographic structure typical of the alloy in the heat-treated condition, similar to that shown in Fig. 478, shows, principally, particles of free silicon in a background of an aluminum-rich primary solid solution.

Alloy 356 is covered by A.S.T.M. Tentative Standard (alloy SG1) B179-T, for ingot, B26-T for sand castings, and B108-T for permanent mold castings, as well as by S.A.E. No. 323.

#### HIGH-STRENGTH MAGNESIUM ALLOYS

Magnesium alloys are somewhat difficult to roll satisfactorily, and hence structural members made of them usually are extruded. However, parts that are amenable to forging may be shaped by this process. The compositions usually extruded contain 2.5-10.5% aluminum to improve the mechanical properties, more than 0.15% manganese to improve the corrosion resistance, and 0.3-3.5% zinc. In addition, these alloys generally will contain about 0.5% silicon. The five most important alloys with their A.S.T.M. (B107-T), Mazlo, and Dowmetal designations are:

A.S.T.M. (B107-T)	AMERICAN MAGNESIUM CORPORATION	DOW CHEMICAL COMPANY	% AL	% MN (MIN)	% ZN
AZ31X	AM52S	FS-1	2.5-3.5	0.20	0.6-1.4
AZ61X	AM57S	J-1	5.8-7.2	0.15	0.4-1.5
M1	AM3S	M	—	1.20	—
AZ80X	AM58S	O-1	7.8-9.2	0.12	0.2-0.8

In each case the remainder of the alloy is magnesium and minor impurities.

From the constitutional diagram, alloys containing between 2% and 12% aluminum would be expected to be susceptible to age-hardening because of the precipitation of a secondary solid solution. Practically, however, heat-treatment is most beneficial for alloys containing between 6% and 12% aluminum, and only those containing more than 9% aluminum are improved appreciably by aging. Unfortunately, increasing the aluminum over 5% noticeably lowers the ductility. Photomicrographs of *Dowmetal M* and *O-1* after different treatments are shown in Fig. 479. The major constituent in each is the magnesium-rich solid solution with a fine precipitate, probably of manganese in alloy *M*, and of  $Al_2Mg_2$  in alloy *O-1*.

Depending upon the aluminum content, the higher strength commercial magnesium-aluminum alloys in the extruded condition will develop mechanical properties in the ranges shown in Table XL.

TABLE XL STRENGTH PROPERTIES TYPICAL OF COMMERCIAL MAGNESIUM-ALUMINUM ALLOYS IN THE EXTRUDED CONDITION

---

Tensile strength, psi	36,000-47,000
Yield strength, psi	20,000-34,000
Elongation, % in 2 in.	19-6
Reduction in area, %	32-15
Fatigue endurance limit, psi	6,000-18,000
Brinell hardness (10 mm-500 kg)	42-62

---

The ultimate compressive strength will be appreciably higher, and the yield strength in compression appreciably lower, than similar values in tension. After proper heat-treatment of suitable compositions, the tensile strength, yield strength, and Brinell hardness can be improved somewhat, but both the elongation and the reduction in area will be reduced greatly. However, the compressive strengths will not be influenced to any marked extent. Essentially the same alloys, except with more carefully controlled impurities, are also used for forging under A.S.T.M. Tentative Standard B91-T. In addition two magnesium base alloys have been developed, particularly for hammer forging: *Dowmetal L*, containing 1.8-3.2% aluminum, 2.8-4.2% cadmium, and 0.2% manganese; and *Mazlo AM65S*, containing 3.5% aluminum, 5% tin, and 0.2% manganese (A.S.T.M. alloy AT35), the remainder being magnesium in each instance.

Forged alloys generally will have tensile and yield strengths somewhat

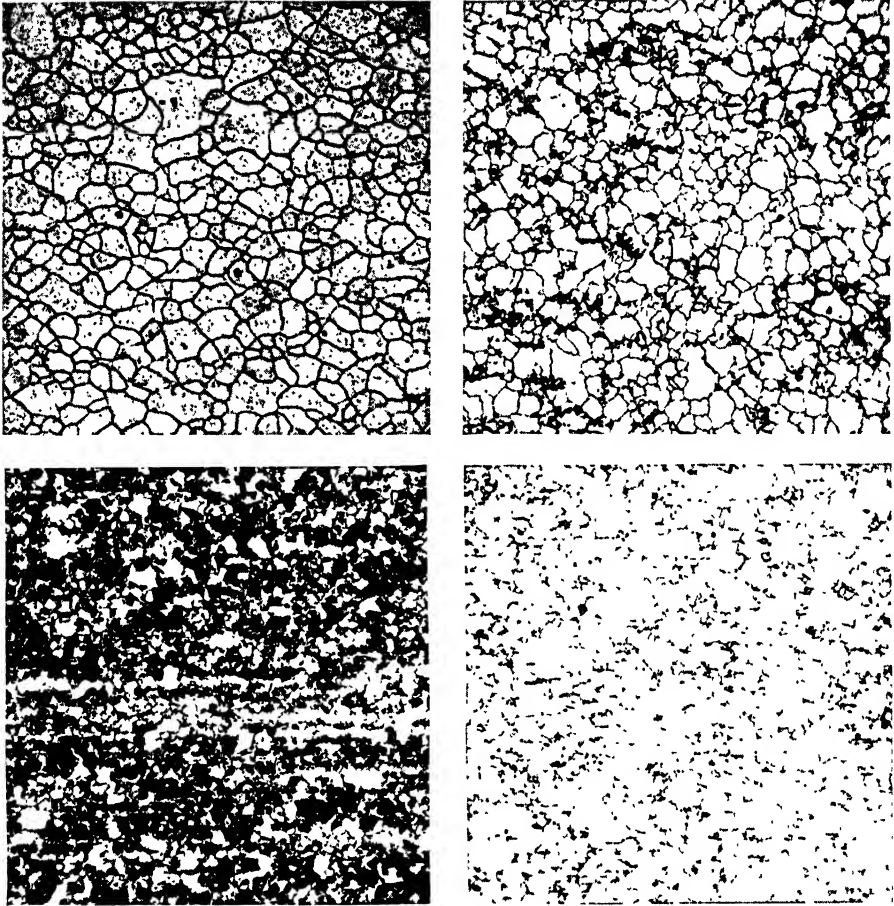


FIGURE 479. Metallographic structures typical of some wrought magnesium alloys. (Photomicrographs courtesy The Dow Chemical Company.)

- a.* (Upper left) Dowmetal Ma (1.5% Mn - rem. Mg) sheet, rolled and annealed. Etched 10 sec with acetic-glycol etchant.  $\times 250$ .
- b.* (Upper right) Dowmetal O-1 (8.5% Al - 0.2% Mn - 0.5% Zn - rem. Mg), extruded. Etched 10 sec with glycol etchant.  $\times 250$ .
- c.* (Lower left) Dowmetal O-1, extruded and heat-treated. Etched 5 sec with glycol etchant.  $\times 250$ .
- d.* (Lower right) Dowmetal O-1, press forged. Etched 5 sec with acetic-glycol etchant.  $\times 250$ .

higher, and elongations somewhat lower than those of the extruded magnesium alloys, although the fatigue endurance limits will be comparable.

Alloys similar to those used for extrusion, but containing somewhat higher percentages of aluminum (5-13%), are used for both sand and permanent mold castings.

The four most common of these casting alloys are:

A.S.T.M. (B80-T)	AMERICAN MAGNESIUM CORPORATION	DOW CHEMICAL COMPANY	% AL	% ZN	% MN (MIN)
A10	AM240	G	9-11	0.3 max	0.1
AZ63	AM265	H	5.3-6.7	2.5-3.5	0.15
AZ92	AM260	C	8.3-9.7	1.6-2.4	0.1
M1	AM403	M	—	—	1.2

the remainder being magnesium in each case. These alloys and some additional ones are covered by A.S.T.M. Tentative Standards B80-T (Sand Castings), B199-T (Permanent Mold Castings), and B93-T (Ingots). Even in the fully heat-treated condition, the maximum properties secured in them will be about 39,000 psi tensile strength, and 21,000 psi yield strength. Frequently much lower values are found. However, for castings, such properties are quite satisfactory because of the larger sections usually involved and the low specific gravity of the alloy.

Probably the biggest disadvantage of magnesium alloys is their *notch sensitivity*, i.e., sensitivity to local concentrations of stresses, which is present despite a good resistance to fatigue. For this reason sharp corners must be avoided in magnesium castings and shapes wherever possible, notches and scratches of all kinds must be eliminated, and liberal fillets should be provided, especially when stresses are apt to be high.

The magnesium alloys are used extensively wherever their characteristics of light weight, high strength, and machinability can be advantageous, as in aircraft motors and structural parts, parts of rapidly moving machinery in the textile, packaging, cigarette and similar industries, portable equipment of all sorts, patterns and core boxes for foundry uses, and in office furniture and equipment. Several S.A.E. and AMS Standards cover them in addition to the A.S.T.M. Standards already mentioned.

Metallographic structures typical of cast *Dowmetal C*, in various conditions, and aged *Dowmetal H* are shown in Fig. 480. They consist essentially of a magnesium-rich solid solution containing particles of massive  $\gamma(\text{Mg}_3\text{Al}_2)$  + zinc compound, plus, in all but the heat-treated structure (Fig. 480*b*), a lamellar form of the compound precipitated either by aging or else by cooling at sufficiently slow rates. A few small manganese particles also can be seen.

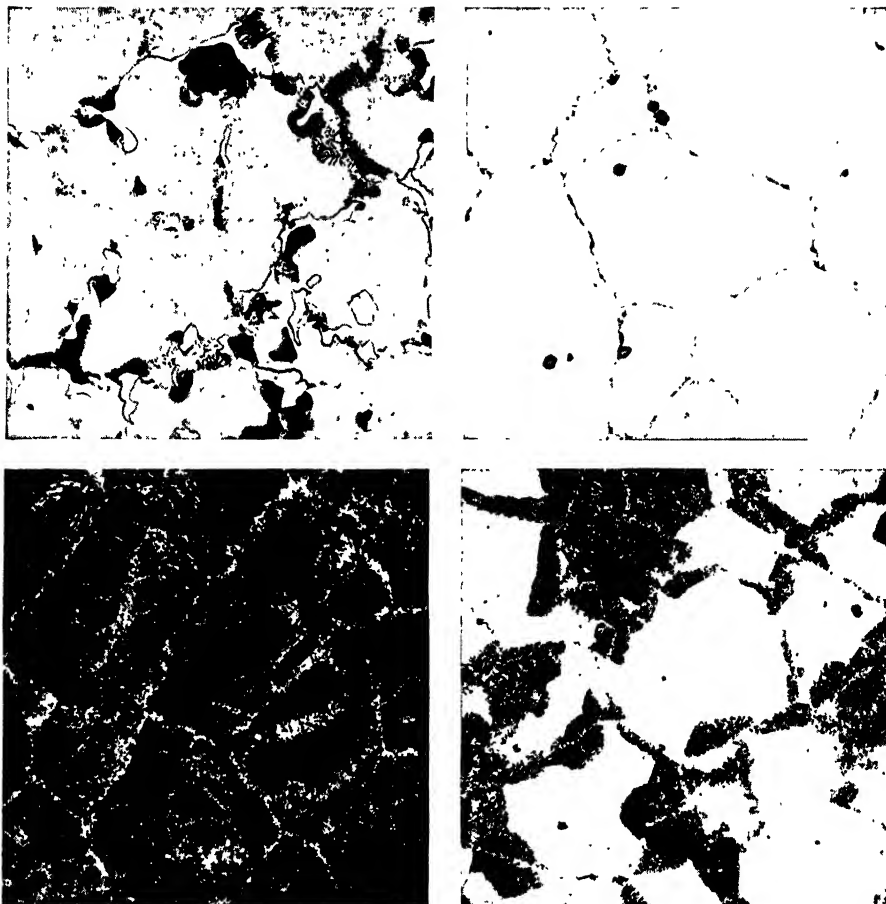


FIGURE 480. Metallographic structures typical of some cast magnesium alloys. (Photomicrographs courtesy The Dow Chemical Company.)

- a.* (Upper left) Dowmetal C (9% Al—2% Zn—0.1% Mn—rem. Mg), as sand cast. Etched 5 sec with glycol etchant.  $\times 250$ . Sand-cast Dowmetal H (6% Al—3% Zn—0.2% Mn—rem. Mg) and permanent-mold castings of both alloys would have similar structures.
- b.* (Upper right) Dowmetal C, sand-cast and solution heat-treated. Etched 10 sec with glycol etchant.  $\times 250$ . Dowmetal H would be similar in this condition.
- c.* (Lower left) Dowmetal C, sand-cast, solution heat-treated and aged. Etched 5 sec with glycol etchant.  $\times 250$ .
- d.* (Lower right) Dowmetal H, sand-cast, solution heat-treated and aged. Etched 5 sec with glycol etchant.  $\times 250$ .

## *Copper Alloys*

### SILICON BRONZES

An extensive group of alloys, called the silicon bronzes, in which copper and silicon are the major elements, has been developed by the copper

industry as structural materials. They are the strongest of the work-hardening copper-base alloys and are sold under a variety of trade names, the most important of which are: *Cusiloy*, *Duronze II*, *Everdur*, *Herculoy*, and *Olympic Bronze*. All of these alloys contain 95–97% copper, 3% silicon, and 1% or more of the elements zinc, tin, or manganese. In addition several different modifications of these basic analyses, some of them radically different in nature, are sold under the same general names.

Although most of these are proprietary alloys, they are all similar metallographically, and have essentially the same properties. All are covered by A.S.T.M. Standards B96, B97, B98, B99, and B100.

Several of the alloys are made in free-machining varieties containing about 0.5% lead, as well as in varieties intended primarily for casting, or for use as welding rods. These latter generally contain 3% silicon alone with no other alloying additions.

The silicon bronzes can be worked readily both hot and cold, although certain compositions are preferred primarily for forging. After cold-working they will recrystallize at about 750 F (400 C) for heavy reductions, and at somewhat higher temperatures for lighter reductions. The recommended annealing range is 900–1300 F (475–700 C). All of the alloying elements are in solid solution, so the metallographic structure is that of a typical twinned  $\alpha$  solid solution, similar to many of the other copper-base alloys, although it usually has a fine grain size. Figure 481 is a typical photomicrograph.

The properties of these alloys in the form of 0.040-in. thick strip, both after cold-working and after annealing at various temperatures, and in the form of drawn rod are indicated in Fig. 482. The silicon bronzes generally have a satisfactory corrosion resistance which is usually at least equal to that of copper, if not somewhat superior because of the tendency of a sub-microscopic protective surface layer of silica to form. However, in steam atmospheres they are susceptible to stress corrosion.

They can be welded by the oxyacetylene, metallic-arc, and resistance methods;<sup>29</sup> and are accepted for unfired pressure vessels by the A.S.M.E.

<sup>29</sup> See, for example, I. T. Hook, *Journ. Amer. Weld. Soc. Supl.*, February and March, 1937; E. S. Bunn, J. R. Hunter and W. G. Seidlitz, *ibid.*, 17, 1938, 1–6; D. K. Crampton and J. J. Vreeland, *ibid.*, October 1937, 9–18.



FIGURE 481. Metallographic structure of an annealed silicon bronze. Etched with  $\text{NH}_4\text{OH} + \text{H}_2\text{O}_2$ .  $\times 75$ . (Photomicrograph courtesy Research Department, Chase Brass & Copper Co.)

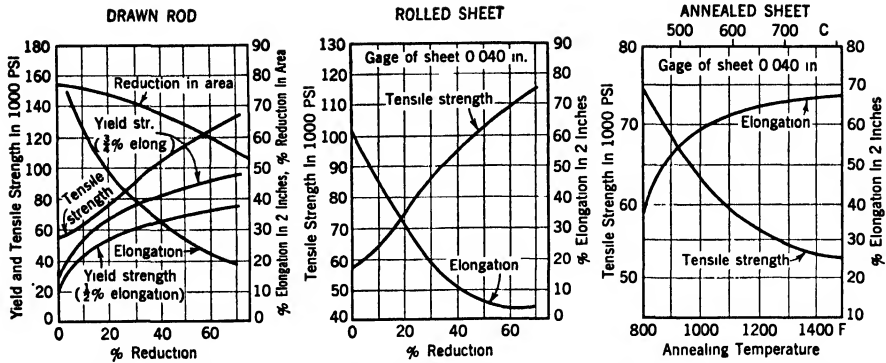


FIGURE 482. Tensile properties obtainable with different forms and treatments of a standard wrought silicon bronze.

a. (Left) Tensile properties of drawn rod.

b. (Center) Tensile properties of 0.040-in. rolled sheet.

c. (Right) Tensile properties of 0.040-in. annealed sheet.

(From *Chase Olympic Bronze*, courtesy Chase Brass & Copper Co.)

Boiler Code Committee at a 10,000 psi working stress for all temperatures from room temperature up to 250 F (120 C); and at a maximum working stress of 5000 psi from 250–350 F (120–175 C), provided the material is satisfactory for the intended service in other respects. The alloys also are used for bolts, cable, rivets, structural shapes, propeller shafts, and springs. Their main disadvantages from a purely structural viewpoint are their weight and cost.

### BRONZE

The wrought bronzes are alloys of copper with, as a rule, no more than 11% tin. Only the  $\alpha$  solid solution, as has been discussed already in Chap. VIII, has properties of commercial importance. When these alloys are deoxidized with phosphorus, or when phosphor-tin is used, they generally are known as *phosphor bronzes*, even though the residual phosphorus content always will be less than 0.50%.

Three grades of wrought phosphor bronze have been standardized on by the industry, all of them covered by A.S.T.M. Tentative Standards B159-T (Wire), and B139-T (Rods, Bars, and Shapes):

GRADE	% SN	% P	% ZN*
A	3.8–5.8	0.03–0.35	0.30
C	7.0–9.0	0.03–0.35	0.20
D	9.0–11.0	0.03–0.25	0.20

\* Max

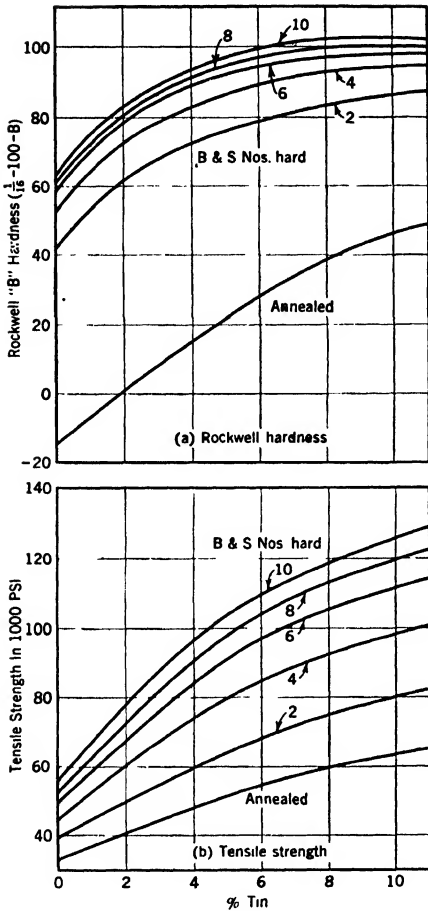


FIGURE 483. (Left) Change in the mechanical properties of annealed and cold-rolled phosphor bronze sheet with tin content. Average grain diameter 0.050 mm, minimum gauge of sheet 0.040 in. In each case bottom curve represents annealed material, other curves same material but rolled as indicated.

a. Rockwell hardness. b. Tensile strength.

(From *Metals Handbook*, courtesy American Society for Metals.)

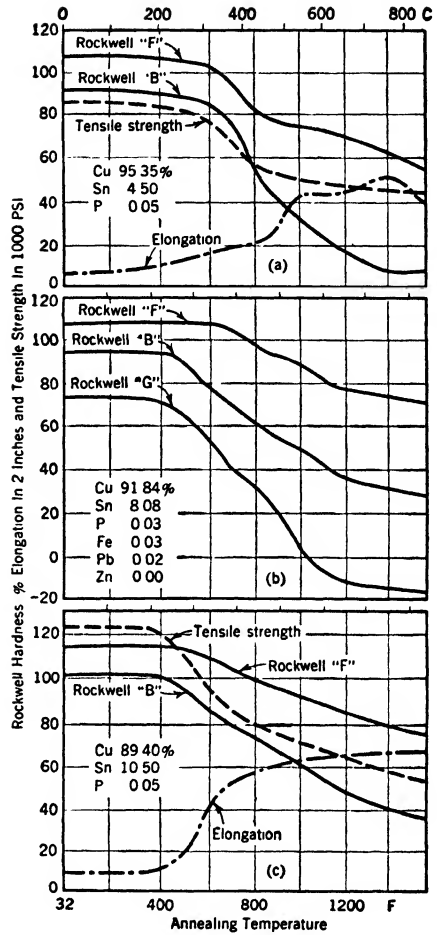


FIGURE 484. (Right) Mechanical properties of 0.040-in. thick phosphor bronze sheet. Reduced 50% in thickness by rolling and annealed  $\frac{1}{2}$  hr at temperature noted.

a. Grade A. b. Grade C. c. Grade D.

(From *Metals Handbook*, courtesy American Society for Metals.)

In all three grades, the remainder is copper and minor impurities. Iron is held to 0.10% (max), and lead to 0.05% (max). These three grades, in the form of sheet, are also covered by A.S.T.M. Standard B103. Grade A wire corresponds to S.A.E. No. 81, and Grades A and C strip to S.A.E. No. 77.

The phosphor bronzes are used most extensively for applications, such



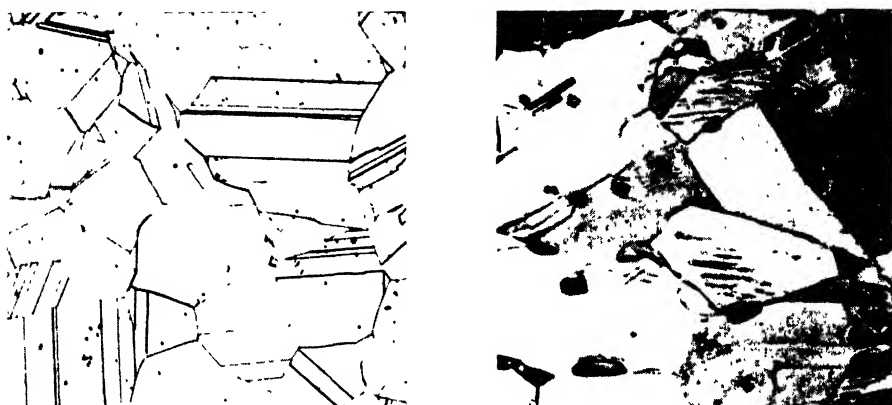


FIGURE 485. Metallographic structures of annealed phosphor bronze. Etched with  $\text{NH}_4\text{OH} + \text{H}_2\text{O}_2$ .

*a.* (Left) Non-leded.  $\times 100$ . *b.* (Right) Leded.  $\times 500$ .

(Photomicrographs by L. Litchfield.)

as springs, diaphragms, bridge bearing plates, and wire rope, which require high resilience, fatigue and wear resistance. Typical mechanical properties are shown in Fig. 483. Excellent strengths are secured, especially in the cold-worked condition. The change in hardness on annealing, shown in Fig. 484, indicates that noticeable softening begins at about 700 F (370 C) for Grade A, and about 600 F (320 C) for Grades C and D for strip 0.040-in. thick that had been cold-rolled 50% and held  $1\frac{1}{2}$  hr at temperature. Commercial annealing temperatures are usually much higher than these initial softening temperatures, however.

The microstructure of these  $\alpha$  copper-tin alloys (Fig. 485*a*) is very similar to that of the brasses, consisting entirely of typical twinned  $\alpha$  solid solution grains. However, in contrast to many of the brasses, the bronzes have the characteristic reddish color which is named after them. Bronzes usually are fabricated by cold-working since only the alloys containing less than 2% tin can be hot-worked satisfactorily. Their corrosion resistance is comparable to that of copper.

Wrought leded compositions, which have excellent machinabilities in addition to their other properties, also are made for use as bearings, bushings, and screw-machine products. The most important of these are:

GRADE	% SN	% PB	% P*	% ZN
<i>B</i>	4.0–5.5	2.5–4.0	0.25	—
<i>B1</i>	3.5–5.8	0.8–1.25	0.35	—
<i>B2</i>	3.5–4.5	3.5–4.5	0.5	3.0–4.5

\* Max

the remainder of the alloy being copper in each case. These leaded alloys will have mechanical properties comparable with those of the nonleaded alloys, and their microstructures will differ from those of the lead-free alloys only in the appearance of particles of insoluble lead as shown in Fig. 485*b*. Their biggest disadvantages are a tendency for the lead to segregate and the tendency, common to most leaded copper alloys, of being hot-short. The first two compositions listed are sheet alloys (A.S.T.M. B103), and the last two are rod alloys (A.S.T.M. B139-T).

## NICKEL BRONZE

The nickel-bronze sand casting alloys analyzing:

% NI	% SN	% ZN	% P
5.0-5.5	5.0-5.5	1-2	0.03-0.05
7.5	8	2	trace

are made much more readily than the ordinary phosphor bronze castings because the addition of nickel increases the strength, fluidity, and hydraulic tightness, and reduces the grain size. It also makes the alloy age-hardenable if the composition is balanced properly.<sup>30</sup>

The usual annealing or homogenizing treatment is 5 hr at 1400 F (760 C) followed by a rapid cooling, the severity of which depends on the casting. Aging for 5 hr at 550-600 F (290-315 C) then will give the best combination of strength and ductility. Average mechanical properties for the softer 5:5:2 alloy, in various conditions, are given in Table XLI.

TABLE XLI STRENGTH PROPERTIES TYPICAL OF A 5:5:2 NICKEL-BRONZE CASTING IN VARIOUS CONDITIONS

	TENSILE STRENGTH, PSI	YIELD STRENGTH (0.5% ELONG.), PSI	ELON- GATION, % IN 2 IN.	BRINELL HARDNESS (10 MM- 1000 KG)
As cast	48,000	29,000	40	86*
Cast and aged 10 hr at 550 F	73,000	61,000	5	170
Cast and annealed 10 hr at 1400 F, quenched, and aged 5 hr at 550 F	87,000	70,000	10	190

\* 500 kg load

<sup>30</sup> See, for example, E. M. Wise and J. T. Eash, *Trans. A.I.M.E.*, 111, 1934, 218-242.

A metallographic structure typical of the 5:5:2 alloy is shown in Fig. 486a. In general this consists of a few particles of undissolved copper-tin secondary solid solution (probably  $\delta(\text{Cu}_4\text{Sn})$ ) in a matrix of a dendritic primary solid solution of nickel and tin in copper.

Wrought alloys of similar compositions can be heat-treated to give even better properties than those of the cast alloys.

The so-called leaded nickel-bronze casting alloys, which are available commercially (A.S.T.M. B149-T), actually are leaded nickel silvers and, hence, are an entirely different type of alloy.

#### WROUGHT MANGANESE BRONZE

The so-called wrought manganese-bronze alloys, which have been used extensively for high-strength forgings, valve stems, bolts and nuts, and welding rod, are actually alpha-beta brasses of the Muntz metal type, which have been improved by the addition of small amounts of tin, iron, and manganese. These elements increase the strength and hardness, inhibit grain growth, and reduce the tendency toward dezincification. Typical analyses would fall within the limits:

TYPE	% CU	% SN	% FE	% MN	% AL	% ZN	% PB
A	57-60	0.5-1.5	0.8-2.0	0.50*	0.25*	rem.	0.20*
B	63-68	0.50*	2.0-4.0	2.5-5.0	3.0-6.0	rem.	0.20*

\* Max

Tensile strengths, in the hot-rolled condition, will average 55,000-85,000 psi, depending on the type, with yield strengths (0.5% elongation) of 22,000-45,000 psi and elongations of 25% in 2 in. By cold-working, the tensile strength can be increased to 80,000-115,000 psi, with a yield strength of 45,000-68,000 psi, and an elongation of 10-20%. The alloys have excellent hot-working properties, especially in the range 1150-1300 F (620-700 C), but they cold-work relatively poorly like the other alpha-beta brasses. Their machinability is about 30% that of free-cutting brass.

Wrought shapes are covered by A.S.T.M. Standard B138, and Federal Specification QQ-B-721a (Class A); and welding rod by QQ-R-571.

#### CAST MANGANESE BRONZE.

Typical manganese-bronze castings, covered by A.S.T.M. Tentative Standards B30-T (Ingot), B132-T and B147-T (Sand Castings), S.A.E. 43 and 430, and Federal QQ-B-726b, have the nominal compositions:

COMMERCIAL DESIGNATION	% CU	% ZN	% SN	% MN	% AL	% FE	% PB
<i>Leaded manganese bronze</i>	61.0	rem.	0.75	0.25	0.75	1.00	0.72
<i>No. 1 manganese bronze</i>	58.0	rem.	1.0*	0.25	1.25	1.25	0.40*
<i>High-strength manganese bronze</i>	64.0	rem.	0.50*	3.50	5.00	3.00	0.20*

\* Max

The alloys have a high shrinkage and, because of their composition, a comparatively high tendency to dross, but both of these objectionable features can be overcome by proper design and casting techniques.

Very good mechanical properties can be secured in castings, typical values of which are given in Table XLII. In addition, in sound castings

TABLE XLII STRENGTH PROPERTIES TYPICAL OF THE CAST MANGANESE BRONZES

COMMERCIAL DESIGNATION	TENSILE STRENGTH, PSI	YIELD STRENGTH, PSI	ELONGATION, % IN 2 IN.	BRINELL HARDNESS (10 MM-500 KG)
<i>Leaded manganese bronze</i>	60,000-78,000	25,000-40,000	15-30	80-95
<i>No. 1 manganese bronze</i>	70,000-88,000	28,000-40,000	20-35	90-120 115-150*
<i>High-strength manganese bronze</i>	100,000-120,000	65,000-90,000	8-18	170-225 190-235*

\* 3000 kg

Izod impact strengths will run 20-40 ft-lb in the first two and 7-12 ft-lb in the last type.

Because of their excellent combination of strength, ductility, and corrosion resistance, these alloys are used widely for marine castings such as valve stems, propellers, pump bodies, engine framing and bases, worms, gears, hydraulic cylinder parts, and many other applications requiring high-strength corrosion-resisting castings.

Metallographic structures, as shown in Fig. 486*b*, are in general similar to those of a fine grain alpha-beta brass of the Muntz metal type although the structures of some compositions may be considerably more complex.

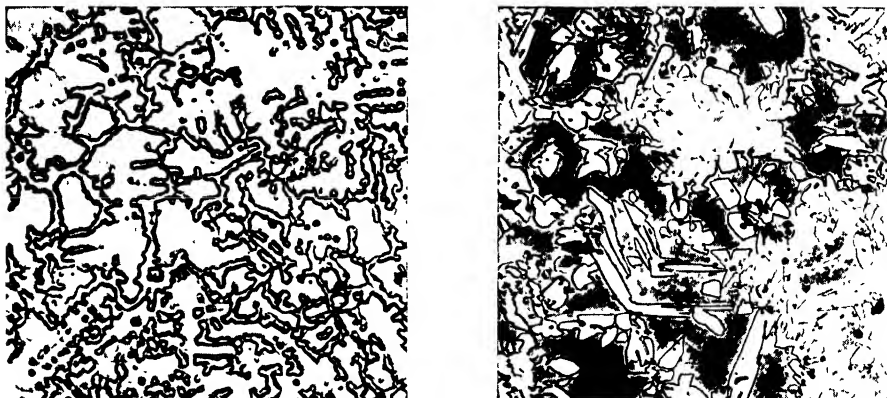


FIGURE 486. Metallographic structures of high-strength copper-base casting alloys. *a.* (Left) Chill-cast nickel bronze (5% Ni - 5% Sn - 2% Zn - rem. Cu). Etched with  $\text{NH}_4\text{OH} + \text{H}_2\text{O}_2$ .  $\times 100$ .

(Photomicrograph by L. Litchfield.)

*b.* (Right) Cast manganese bronze (60% Cu - 2% Sn - 3% Mn - 1% Al - 1.5% Fe - 0.5% Pb - rem. Zn). Etched with  $\text{FeCl}_3$  to darken the  $\beta$ .  $\times 100$ .

(Photomicrograph courtesy Crane Co. Research Laboratories.)

The black spots are probably the iron constituent which always is profuse in these alloys.

#### BERYLLIUM COPPER

The alloys of copper with 2-2.25% beryllium, 0.50% (max) nickel or cobalt, and 0.25% (max) iron have been used to some extent because of their excellent combination of high hardness, strength, and wear and fatigue resistance, with a corrosion resistance at least as good as that of copper.<sup>31</sup> They sometimes are referred to as the *beryllium bronzes*. The chief obstacle to their use thus far has been their high cost, resulting from licensing fees, the price of beryllium, and casting and fabricating difficulties with the alloy. This has restricted them largely to applications such as bolts, springs, gears, diaphragms, watch parts, bearings, bushings, and ball cages in the electrical, aircraft, and other fields in which the alloy cost per pound becomes relatively unimportant, either because the products are sold individually rather than by weight, or for other reasons. The alloy has a higher fatigue resistance than any other copper-base alloy, and a better wear resistance than phosphor bronze when run against any grade of steel, especially under light loading and without lubrication. Beryllium is the hardening agent, the nickel or cobalt and iron merely serving to refine the grain size.

<sup>31</sup> For complete information see *Beryllium: Its Production and Application*. Translated by R. Rimbach and A. J. Michel. The Chemical Catalogue Company, New York, 1932.

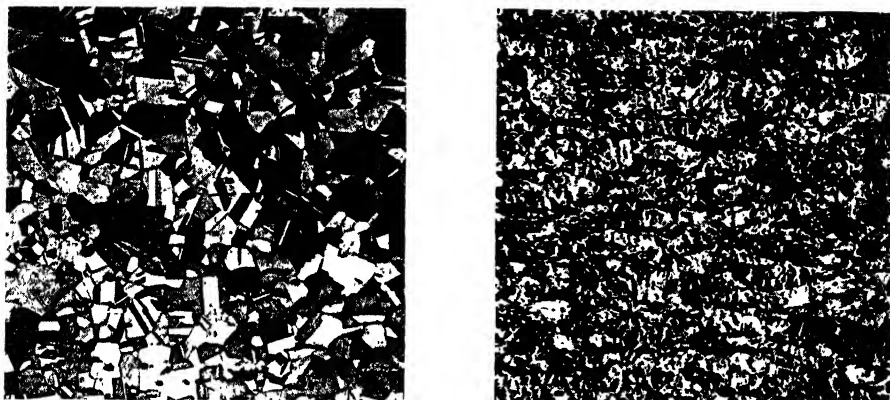


FIGURE 487. Metallographic structures of beryllium copper (2.25% Be - 0.25% Ni - rem. Cu). Etched with  $\text{FeCl}_3$  to blacken the  $\beta$  phase.  $\times 75$ .

a. (Left) Quenched after solution heat-treatment. At this magnification the structure would be essentially the same after a precipitation heat-treatment to maximum hardness.

b. (Right) Quenched, rolled 4 B & S No. hard, and precipitation heat-treated.

(Photomicrographs courtesy Technical Department, The American Brass Company.) The structure of a slowly cooled alloy of this type is shown in Fig. 244b. This structure never is encountered commercially if the alloy is to be heat-treated.

Annealing, after cold-work or before precipitation hardening, is secured by water quenching, preferably from a soak at 1425–1475 F (775–800 C) although temperatures as low as 1200 F (650 C) often can be used if maximum properties from aging are not needed. This condition is the softest obtainable and from it the alloy may be hardened either by cold-work or by a heat-treatment in the range 480–620 F (250–325 C), the exact time and temperature depending upon the properties desired. After slow cooling from the annealing temperature, the alloy may be cold-worked, but it cannot then be hardened by heat-treatment unless another solution treatment is given first. This slow cooling is the so-called homogenizing treatment.

The quenched alloy has a typical copper  $\alpha$  solid solution structure (Fig. 487a); but, after aging, a characteristic striated pattern can be found, and often particles of the precipitated  $\beta$  or  $\gamma$  secondary solid solutions are present also (Fig. 487b).

Typical mechanical properties for the alloy in the annealed and hardened conditions are listed in Table XLIII.

Because the temperature of the precipitation treatment is below the recrystallization temperature of the alloy, the effects of precipitation can be superimposed on those of work-hardening. By varying the compositions and the heat-treatments given, tensile strengths higher than 200,000 psi can be produced, making this the strongest of the nonferrous alloys in commercial use today (cf. Fig. 248a).

TABLE XLIII STRENGTH PROPERTIES TYPICAL OF BERYLLIUM BRONZE IN VARIOUS CONDITIONS

	TENSILE STRENGTH, PSI	YIELD STRENGTH (0.75% ELONG.), PSI	ELONGA- TION, % IN 2 IN.	HARDNESS BRINELL (10 MM- 3000 KG)	ROCKWELL HARDNESS*
Soft, quench-annealed	70,000	31,000	45	110	— B65-73
Quenched, heat-treated	175,000	134,000	6	340	C38 B112
Quenched, cold-rolled 4 B. & S. No.	118,000	105,000	4	220	C24 B102
Quenched, cold-rolled, and heat-treated	193,000	138,000	2	365	C41 B114

\*Rockwell values over B100 have little significance.

If maximum properties are not required with this alloy it has been found that much greater toughness can be secured, without serious loss in strength, by overaging rather than underaging. This can be accomplished more easily by aging at a temperature in the vicinity of 750–800 F (400–425 C) than by the alternate method of greatly increasing the aging times in the usual range, 480–620 F (250–325 C).

The major difficulty with the beryllium-copper alloys before World War II was probably the lack of uniformity. So many factors, in addition to segregation, act during melting and fabrication to decrease the amount of *available* beryllium, i.e., beryllium available for alloying with copper as contrasted with that present as oxide, carbide, or other “unavailable” forms, that it was difficult to maintain uniformity. Improvements made during the war period largely overcame this trouble.

A copper-base alloy containing a lower beryllium content (*Berylco 165S*) is also available commercially. It has a lower cost and greater freedom from brittleness, but at a sacrifice of some strength and hardness.

#### COPPER-MANGANESE-NICKEL ALLOY

Largely as a result of research carried out by the Bureau of Mines, a new high-strength copper alloy containing 60% Cu–20% Mn–20% Ni was announced in 1944.<sup>32</sup> This copper-base alloy, like beryllium copper, is subject to precipitation-hardening, but since it is also rather expensive it

<sup>32</sup> See R. S. Dean, J. R. Long, T. R. Graham, and C. W. Matthews, *Trans. A.S.M.*, **34**, 1945, 481–502.

seems to be subject to limitations similar to those stated above for beryllium copper.

- The principal advantages of this alloy over beryllium copper are its corrosion resistance, the improvement in which is largely a function of the manganese and nickel contents, and the relatively low solution treatment, viz., about 1050–1100 F (560–600 C), which can be used with it. Beryllium copper, for maximum hardness must be quenched from 1400 F (760 C) or higher. The principal disadvantages besides its cost seem to be its relatively high electrical resistance, also a function of alloy content, and the relatively long aging times, e.g., 12–16 hr at 650–850 F (350–450 C), required to develop maximum properties.

By proper mechanical and heat treatment, tensile strengths as high as 220,000 psi can be developed, with yield strengths (0.2% offset) of about 170,000 psi, and Rockwell hardnesses of 45–50C. In this condition, of course, both the elongation and reduction in area will be low, about 0–3%, but this is comparable with these properties in beryllium copper of similar hardness.

The alloy is available commercially under the three principal trade names: *Chace 720*, *Wyndalloy 720*, and *Driver-Harris 720*. As yet its probable uses, except in competition with beryllium copper, have not been fully developed.

### *For Further Study Refer to*

1. *Steel and its Heat Treatment*, 4th ed., by D. K. Bullens: John Wiley & Sons, Inc., New York, 1938.
2. *Alloy Constructional Steels*, by H. J. French: American Society for Metals, Cleveland, Ohio, 1942.
3. *What Steel Shall I Use?*, by G. T. Williams: American Society for Metals, Cleveland, Ohio, 1942.
4. *The Making, Shaping, and Treating of Steel*, 5th ed., by J. M. Camp and C. B. Francis: Carnegie-Illinois Steel Corp., Pittsburgh, Pa., 1940.
5. *S.A.E. Handbook*: Society for Automotive Engineers, New York (usually published annually).
6. *Metals Handbook*: American Society for Metals, Cleveland, Ohio, 1939 (usually published triennially). A new edition will appear in 1948.
7. *The Book of Stainless Steels*, 2d ed., edited by E. E. Thum: American Society for Metals, Cleveland, Ohio, 1935.
8. *The Steel Physical Properties Atlas*, by C. N. Dawe: American Society for Metals, Cleveland, Ohio, 1936.



9. *Alloy Cast Irons*: American Foundrymen's Association, Chicago, Ill., 1939.
10. *Copper and Copper Alloys*, by R. A. Wilkins and E. S. Bunn: McGraw-Hill Book Company, Inc., New York, 1943.
11. *Transactions American Society for Metals*: A.S.M., Cleveland, Ohio (published annually).
12. *Metal Progress*: American Society for Metals, Cleveland, Ohio (published monthly).
13. *Materials and Methods* (formerly *Metals and Alloys*): Reinhold Publishing Corporation, New York (published monthly).
14. *Alcoa Aluminum and Its Alloys*: Aluminum Company of America, Pittsburgh, Pa., 1947.
15. *Designing with Magnesium*: American Magnesium Corporation, Pittsburgh, Pa., 1943.
16. *Properties of Magnesium Products*: American Magnesium Corporation, Pittsburgh, Pa., 1943.
17. Publications of:
  - Allegheny-Ludlum Steel Corp., Brackenridge, Pa.
  - Aluminum Company of America, Pittsburgh, Pa.
  - American Brass Co., Waterbury, Conn.
  - American Magnesium Corp., Cleveland, Ohio.
  - American Rolling Mill Co., Middletown, Ohio.
  - Beryllium Corp. of America, Reading, Pa.
  - Bethlehem Steel Co., Bethlehem, Pa.
  - Bridgeport Brass Co., Bridgeport, Conn.
  - Carnegie-Illinois Steel Corp., Pittsburgh, Pa.
  - Carpenter Steel Co., Reading, Pa.
  - Chase Brass & Copper Co., Waterbury, Conn.
  - Dow Chemical Co., Midland, Mich.
  - International Nickel Co., Inc., New York, N. Y.
  - Meehanite Metal Corp., Pittsburgh, Pa.
  - Permanente Metals Corp., Oakland, Cal.
  - Republic Steel Corp., Cleveland, Ohio.
  - Revere Copper & Brass Co., New York, N. Y.
  - Reynolds Metals Corp., Louisville, Ky.
  - Riverside Metal Co., Riverside, N. J.
  - Scovill Mfg. Co., Waterbury, Conn.
  - Seymour Mfg. Co., Seymour, Conn.
  - U. S. Steel Corporation, New York, N. Y.

## Alloys Resistant to General Wear and Abrasion

### CLASSIFICATION OF MATERIALS

THE PROCESSES OF WEAR AND ABRASION TEND TO DECREASE the dimensions of moving parts. This may make these parts either become so small that they are ineffective, as with balls in a ball mill, for example; or else so change the fit between them and other stationary or moving parts as to expose the moving part to unbalanced stresses, thus increasing the possibility of failure by fatigue or other dynamic causes. As a result of wear, also, a metallic part may be worn to such an extent that it will fail from overload; it may be embrittled to such an extent that it will fail from impact; or it may be distorted to such an extent that it no longer will be able to perform satisfactorily the function for which it was designed.

For purposes of discussion, the wear-resistant materials will be classified under four main headings, largely dependent upon the manner in which they are used:

1. *Surface treatments*, which may be used with many alloys, especially those in which other engineering properties predominate, for increasing wear resistance.
2. Alloys for *general engineering applications involving wear resistance* such as railroad rails, switches, car wheels, rolling-mill rolls, excavating and road machinery, piston rings, ball and roller bearings.
3. Alloys for *tools* to withstand cutting, batter, or wear either at atmospheric or at elevated temperatures.
4. Alloys for *bearings*, covering the class of materials usually referred to as *bearing metals*, intended to resist the effects of various types of rolling or sliding friction.

Although there naturally will be some overlapping between these different classifications, this is unavoidable in a discussion as brief as this one must be. Only the first two will be dealt with in this chapter. The last two will be covered in the two succeeding chapters.

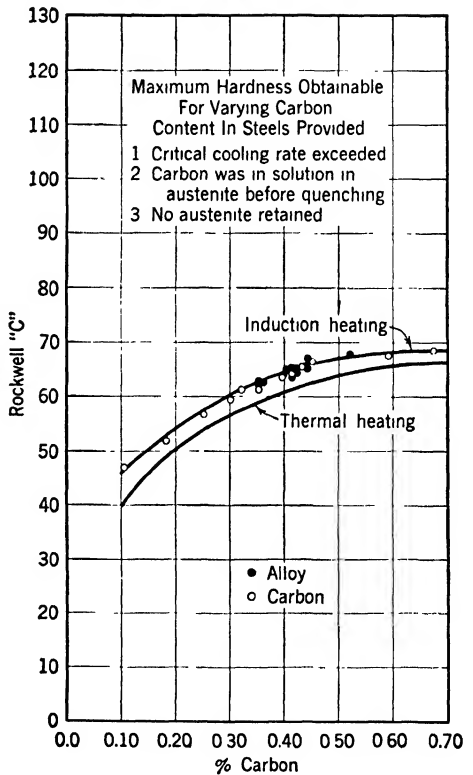
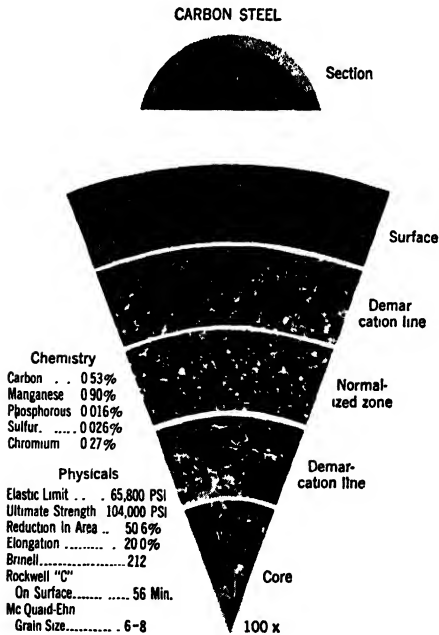
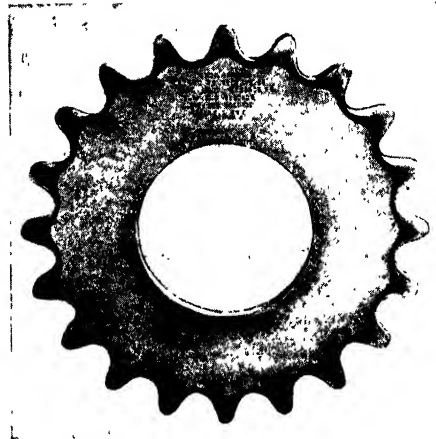
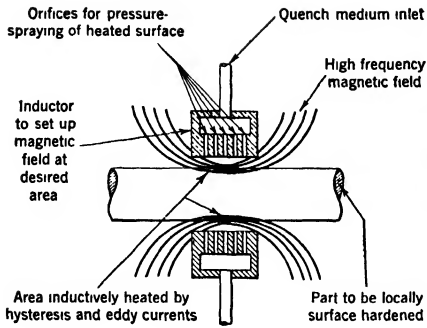


FIGURE 488a. (Upper left) Schematic illustration of the essentials of the process of induction hardening.  
 b. (Upper right) Macrograph of an induction-hardened sprocket illustrating the greatest hardness penetration (dark etching zone).  
 c. (Lower left) Metallographic structure of an induction-hardened forged carbon-steel cylinder illustrating general character of the penetration layer. Etched with nital.  $\times 100$ .

## *Surface Treatments Giving Increased Wear Resistance*

### SURFACE HARDENING

Various methods are used for increasing the surface hardness of steels, usually in order to secure better wear resistance. These may involve not only the heat-treatment of the surface, but also some changes in composition. The most important of these processes are:

1. *Induction hardening*
2. *Flame hardening*
3. *Case carburizing, including cyaniding and Chapmanizing*
4. *Nitriding*

In addition, the use of *electrodeposited chromium*, in thicknesses of about 0.001 in., has increased wear resistance several-fold in some applications, especially where corrosion also enters as an important factor.

### INDUCTION HARDENING

By using induced high-frequency currents and a properly designed unit, heating can be limited to a surface layer which can be controlled to encompass almost any thickness desired.<sup>1</sup> By this method the actual heat-treatment can be confined to the specific wearing surfaces rather than to the entire piece, as is required by the more conventional methods. This is an important point with certain parts of complicated shape, such as crankshafts and camshafts. With other pieces, such as armor-piercing shells, the method gives greater uniformity and a much higher rate of production than is possible by the more conventional methods. Induction hardening requires specially designed coils for each part, but the basic high-frequency equipment can be used throughout. Hence it finds its main application in mass-production work in which short-time heat-treatment, coupled with uniformity and reproducibility, are very desirable if not essential, and in which the large number of parts heat-treated in a comparatively short time helps to cut down the relatively high initial cost to a reasonable unit cost figure.

The essentials of the process as illustrated in Fig. 488*a* are fairly simple.

<sup>1</sup> See F. F. Vaughn, R. V. Farlow, and E. R. Meyer, *Trans. A.S.M.*, 30, 1942, 516-538; also W. E. Benninghoff and H. B. Osborn, Jr., *A.S.M. Preprint*, 1944.

---

*d. (Lower right)* Relation between surface hardness and carbon content in bars hardened by induction heating and by normal thermal heating.

(Courtesy Tocco Division, The Ohio Crankshaft Company; *a, b, c*, are from *The Tocco Process* by H. B. Osborn, Jr.)

With a properly designed induction coil and a definite power input for a definite time, which is usually of the order of a few seconds, the surface of the metal shape can be heated above its critical temperature. Both the depth of heating and the temperature attained are affected by the coil design, the frequency, the power input, and the time. Once the necessary temperature is attained, rapid quenching can be secured by using a water spray passing through the same high-frequency coil. In a matter of seconds this will cool the piece and so give a high surface hardness with an unaffected tough core. The resulting depth of hardening and the gradual variation in microstructure through the hardened zone are illustrated in Fig. 488*b* and *c*. The *Tocco process* was the original method of induction hardening, but several competitive processes are now available commercially. As shown in Fig. 488*d*, the maximum hardness attainable by quenching an induction-heated piece is greater than that secured by quenching after thermal heating. This is believed to result from a finer martensite.

#### FLAME HARDENING

A somewhat similar method of hardening, in which the heating is done by an oxyacetylene flame,<sup>2</sup> is known as *flame hardening*, the *Shorter process*, or *Shorterizing*. The hardened layer can be varied from  $\frac{1}{4}$  in. to a mere skin, depending on the material treated and the method of operation. The process may be adapted for castings, forgings, or rolled sections, and is used for many alloy and plain carbon steels, as well as for cast iron.<sup>3</sup> Large sizes, or pieces in which it is desired to avoid excessive distortion, are particularly suitable for flame hardening. It may be done by either manual or automatic operation, frequently using water-cooled torches and multi-flame tips as illustrated in Fig. 489*a*. A water spray follows the work closely. The hardened surface in an etched cross section of a flame hardened gear tooth can be distinguished readily in Fig. 489*b*. Experience is required in order to secure satisfactory results,<sup>4</sup> and in many instances it is desirable to follow the hardening by a stress-relieving treatment.

#### CASE CARBURIZING

Case carburizing is a modern application of the ancient process of *cementation* in which the hardness of steel is increased by diffusing carbon into the surface at temperatures above the critical and usually within the

<sup>2</sup> See R. L. Rolf, *Trans. A.S.M.*, 27, 1939, 43-54; and J. G. Magrath, *Machinist*, 85, 1941, 581-583, 645-647, 698-699, 748-749, 804-806, 849-851, 915-917.

<sup>3</sup> See, for example, F. G. Seifing, *Iron Age*, 144, 1939, 43-49.

<sup>4</sup> This is illustrated by the discussion of A. L. Hartley, *Mech. Eng.*, 67, 1942, 531-540.

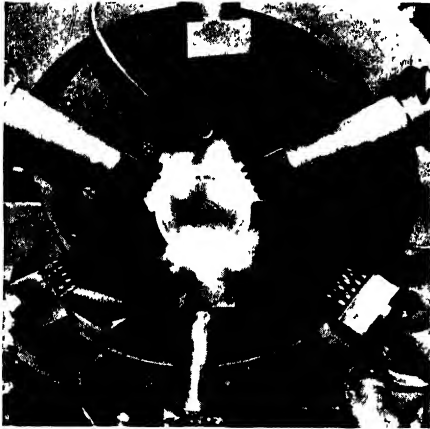


FIGURE 489a. (Left) Photograph illustrating the process of flame hardening.  
b. (Right) Unretouched view of etched cross section of a flame-hardened gear tooth.  
(Courtesy The Linde Air Products Company.)

range 1600–1800 F (870–980 C). The resulting variation in composition from case to core is well illustrated by the metallographic structure of the normalized specimen shown in Fig. 490a.

Either solid, liquid, or gaseous carburizers may serve as the source of carbon.<sup>5</sup>

A commonly used *solid carburizer* is a mixture of hardwood charcoal with about 20% of a metallic carbonate which acts as an “energizer.” Many different types of commercial carburizing compounds are sold under various trade names, but their composition is usually of this general type. Solid carburizers are used in a process known as *pack* or *box carburizing*, because the pieces to be carburized are packed into sealed heat-resistant alloy boxes along with the carburizing agents. All of the solid carburizers depend on the formation of carbon monoxide gas which does the actual carburizing. Because of the mass of metal and compounds that must be heated to the carburizing temperature, pack carburizing usually takes several hours and gives a comparatively thick case.

*Liquid carburizers*, which are chemical salts of the cyanogen radical type that yield carbon by direct or indirect action when heated in contact with the steel, also are used.<sup>6</sup> These salts are solid at room temperature, but liquid at the temperature of use. *Cyaniding* is an application of this method in which the reactive agents are carbon monoxide and nitrogen. In the *Chapmanizing* process, dissociated ammonia gas is bubbled through

<sup>5</sup> See, for complete discussions, Carburizing Symposium, *Trans. A.S.M.*, 26, 1938.

<sup>6</sup> See B. B. Beckwith, *Trans. A.S.M.*, 26, 1938, 752–758.

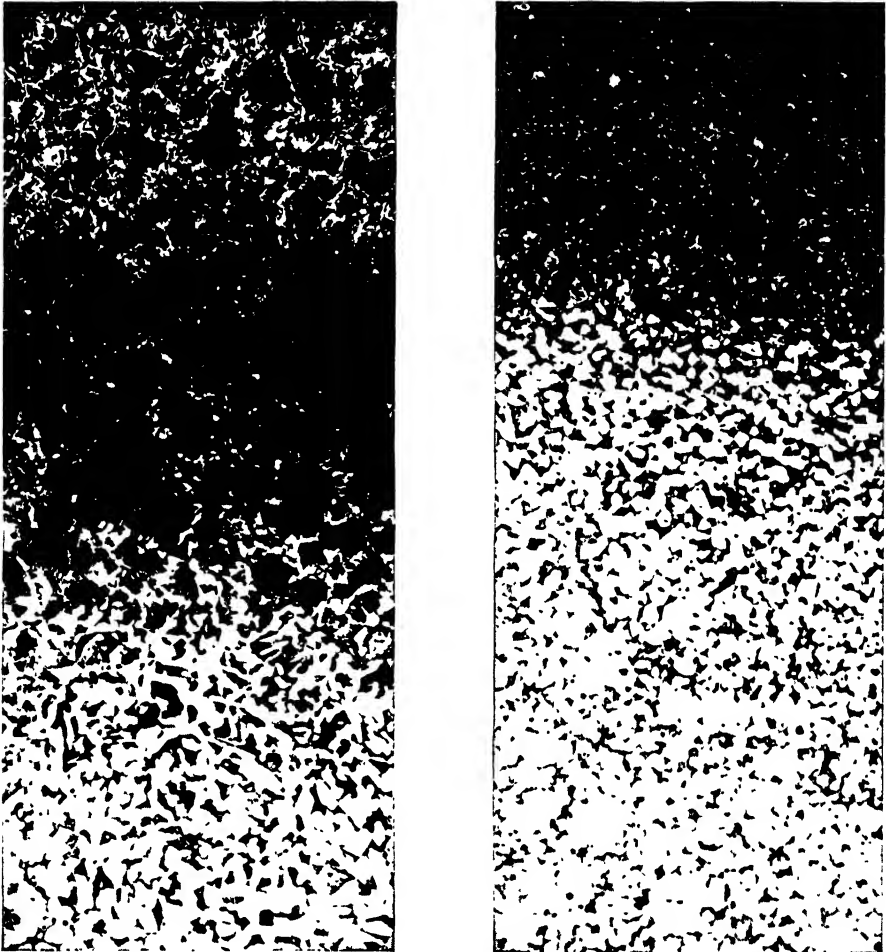


FIGURE 490. Metallographic structures of two different case-carburized steels, showing variation in structure from case (*top*) to core (*bottom*). Etched with nital.

*a.* Normalized.  $\times 50$ . In this specimen the case is hypereutectoid on the surface and eutectoid (dark zone) farther in.

*b.* Oil quenched.  $\times 100$ . The case is much thinner than in *a*, probably because of different carburizing conditions, and, because of the heat treatment, has a much finer structure. (Photomicrographs by L. Litchfield.)

the molten salt bath, thus tending to increase the nitrogen content of the steel also.

*Gaseous carburizers*, such as carbon monoxide and the hydrocarbons methane, ethane, propane, and butane, are used widely. Some of the higher hydrocarbons are cracked in preheating furnaces and the products of this reaction used for the actual carburizing. The commercial *Vapocarb* process is of this type. Mixtures of carbon monoxide and hydrogen, in the

form of water gas or hydrocarbons, and ammonia, also have been used to give combined carburizing and nitriding.<sup>7</sup> The *Nicarb* process is of this latter type.

The cases produced by carburizing usually will not exceed  $\frac{1}{8}$  in., and frequently are less than  $\frac{1}{16}$  in. thick. The required thickness depends largely on the type of application, the loading, and the amount of grinding that must be done after carburizing. The thicker the case in general, the greater the wear and shock resistance, although several other factors must be considered as discussed already in Chap. XVI. Cases produced by cyaniding and Chapmanizing are usually thinner than those produced by the more common carburizing methods.

The relationship between time, temperature, and carbon penetration by case hardening, in a nickel steel containing 1% nickel and 0.15% carbon (S.A.E. 3115), is shown in Fig. 491, and gives a good idea of the time required for gas carburizing under the usual conditions. Data for S.A.E. 1020 and 4320 steels have been given already in Fig. 466.

The usual times for cyaniding and Chapmanizing are much shorter than these, averaging  $\frac{1}{3}$  hr for case depths less than 0.02 in. The temperature for cyaniding is also somewhat lower, 1400–1600 F (760–870 C), and the case will vary with the cyanide content of the bath. *In using any process in which the presence of a cyanide is required, special care must be taken to ensure satisfactory and adequate ventilation. The gases given off are poisonous* so this point cannot be emphasized too strongly.

#### SELECTIVE CARBURIZING

When it is desired to carburize only certain portions of the piece, some method of protecting the “soft” parts is needed. Commonly used for this purpose are:

1. *Copper plating* of the parts to be left soft.
  2. *Carbonaceous cement* covering the parts to be hardened, and heat-treatment in a noncarburizing atmosphere.
  3. *Sand packing* of the soft parts.
  4. *Machining or grinding* off excess stock on the soft spots after carburizing.
- The difficulties arising from the necessity of using selective carburization is one of the reasons for the present widespread use of induction hardening, especially for complex parts. In fact, induction hardening first was developed to get away from the distortion and other problems encountered in the selective carburizing of automotive crankshafts.

<sup>7</sup> See L. D. Gable and E. S. Rowland, *Trans. A.S.M.*, 26, 1938, 706–735; G. T. Williams, *ibid.*, 463–483; and J. F. Wyzalek and M. H. Folkner, *Heat Treating and Forging*, 28, 1942, 39–42, 89–90, 93.



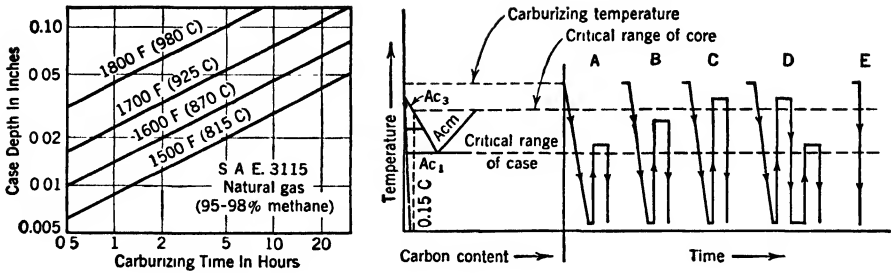


FIGURE 491. (Left) Relation between time and carbon penetration for several carburizing temperatures. Carburized in vertical gas retort using natural gas (90–98% methane). Measurements made on a triangular test specimen. S.A.E. 3115 steel. (After data of R. W. Schlumpf.)

Note that both the case depth and the time have been plotted on logarithmic scales.

FIGURE 492. (Right) Diagrammatic representation of various hardening treatments for carburized steels and summary of case and core properties.

1. Best adapted to fine-grained steels: *A*. Case refined without dissolving excess carbides; core unrefined, soft and machinable. *B*. Case slightly coarsened with some solution of excess carbides; core partially refined, stronger and tougher than *A*. *C*. Case somewhat coarsened with solution of excess carbide favored and austenite retention promoted in highly alloyed steels; core refined to maximum strength and hardness and better combination of strength and ductility than in previous treatments.
2. Best treatment for coarse-grained steels: *D*. Case refined with solution of excess carbide favored and austenite retention minimized; core refined and made soft and machinable with maximum toughness and resistance to impact.
3. Adapted to fine-grained steels only: *E*. Case unrefined with excess carbide dissolved, austenite retained, and distortion minimized; core unrefined but hardened.

(From *Nickel Alloy Steels*, courtesy The International Nickel Company, Inc.)

#### HEAT-TREATMENT AFTER CARBURIZING

Certain difficulties arise in the heat-treatment of plain carbon steels after carburizing because of the different carbon contents of the case and the core. The lower carbon core should be heated above the upper critical  $A_3$ , before cooling, whereas the higher carbon case need only be heated above the lower critical,  $A_1$ . There is an appreciable temperature difference between these two critical temperatures, and the use of the former may well coarsen the grain in the case whereas the use of the latter will probably not give a homogeneous core.

One of the most important reasons for grain-size control in the carburized case is its effect upon the wear resistance. The optimum wear-resisting characteristics result from the presence of excess carbides in the case, i.e., a hypereutectoid case. However, if these carbides are present in a coarse network this region tends also to be comparatively brittle. Hence, the best combination of properties is secured by keeping the grain size

small and the carbides, therefore, well dispersed in a relatively thin grain boundary network.

Either a single or a double heat-treatment can be used, depending upon the alloy, its grain-size characteristics, and whether or not it is necessary to refine the grain size and harden both the case and the core or merely the case alone. Some of the methods of heat-treatment that may be used for various types of steels, with respect to inherent grain-size characteristics, are indicated diagrammatically in Fig. 492. It can be seen from this that grain-size control in carburizing steels is usually quite desirable.

The use of alloying elements not only tends to keep the core grain size fine, but also permits somewhat greater leeway in the selection of type and temperature of heat-treatment and in the rate of quenching of the case to secure a definite hardness. The metallographic structure of a carburized low-carbon steel after heat-treatment is shown in Fig. 490b.

#### THE MCQUAID-EHN TEST

About 1920 it was found that even steels of almost identical chemical analyses did not necessarily behave similarly when case carburized. The McQuaid-Ehn test<sup>8</sup> was developed in order to determine from an easily made test what the reaction of the final carburized product to heat-treatment would be. The test is carried out by carburizing at 1700 F (925 C) for a time necessary to produce a case approximately 0.050 in. thick. A case of this thickness readily can be studied metallographically at 100 diameters magnification. The cooling rate used must be slow enough to permit the formation of a coarsely pearlitic structure, and thus will be determined, to a large extent, by the chemical composition of the steel, the alloy steels requiring somewhat slower rates of cooling than the plain carbon steels. Metallographic examination of the test specimen will give information as to the austenitic grain size of the material at the carburizing temperature, and the nature of the cementite and pearlite formation in the hyper-eutectoid zone. These factors tell whether the steel is *normal* or *abnormal*,<sup>9</sup> as illustrated in Fig. 493.<sup>10</sup>

Sometimes the test is run at three or four temperatures in order to locate

<sup>8</sup> See H. W. McQuaid and E. W. Ehn, *Trans. A.I.M.E.*, **67**, 1922, 341-391.

<sup>9</sup> In the *normal* steel the pearlitic "grains" are outlined by a thin regular band of cementite whereas in the *abnormal* steel there is a definite region containing free ferrite between relatively thick and often discontinuous cementite boundaries and the pearlitic areas. Actually, of course, the names were designated more or less arbitrarily and it is not known specifically which are the truly "normal" structures.

<sup>10</sup> See M. A. Grossman, *Trans. A.S.M.*, **18**, 1930, 601; and E. S. Davenport and E. C. Bain, *ibid.*, **22**, 1934, 879-921.



FIGURE 493. Metallographic structures of typical examples of (left) normal and (right) abnormal steels after standard McQuaid-Ehn treatment. Etched with picral.  $\times 1000$ , originally; reduced about one half in reproduction. (Photomicrographs courtesy U. S. Steel Corporation Research Laboratory, Kearny, N. J.)

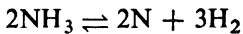
also the approximate grain-size coarsening temperature of the steel. It must be remembered that *this test gives the grain size only under definite conditions of case carburizing*, and that actually it gives comparatively little information concerning the grain size of the steel under conditions other than those covered by the test.

The original classification into “normal” and “abnormal” was based largely upon the reaction to heat-treatment of these steels after carburizing. The “abnormal” steels failed to harden uniformly when treated in accordance with standard quenching practice, and even when they were re-carburized they failed to respond normally and harden without soft spots.

These low-carbon, low-silicon, carburizing steels were, of course, so lacking in all elements which would increase hardenability that the base alloy, in the sections affected, had to have almost maximum hardenability itself, including all the assistance it could get from a coarse grain size, if it was to harden without soft spots. In general, the “abnormal” steels tended to be fine-grained and the “normal” steels coarse-grained although the difference in grain size was not observed nearly so easily as the difference in structural characteristics, and, hence, was overlooked at first. This difference in grain size accounted to a large extent, therefore, for the difference in hardenability of the two structures as well as for their different machining characteristics since the relatively coarse-grained normal steels, as a rule, also had a much better machinability than the relatively fine-grained abnormal steels.

## NITRIDING

Nitriding<sup>11</sup> is a process of casehardening resulting from the presence of iron or alloy nitrides instead of iron carbide. Needles of iron nitride are illustrated in Fig. 494 although in a properly nitrided case they are seldom if ever this large. The process is carried out in the lower temperature range of 930–1000 F (500–540 C), usually in a sealed container in an atmosphere of dissociated ammonia gas:



The activated nitrogen so produced is the nitriding agent, but the hydrogen also may exert a beneficial effect. Times of the order of 90 hr, very much longer than are required for carburizing, are necessary in order to produce an adequate nitride case. Even with the longer time, however, the case depths are very much less than in carburizing, usually averaging about 0.015 in. The case hardnesses will be much higher than those produced by carburizing, typical values being 80–85 Rockwell 30N (Superficial hardness with a spheroconical diamond (Brale) and a 30 kg load), or 1000–1100 Vickers diamond (10 kg load).

Recently, interest also has been shown in nitriding by the use of synthetic urea or other organic nitrogen-bearing compounds<sup>12</sup> which evolve ammonia on heating. The results appear to be comparable to those obtained with the commercial processes mentioned above. The method is of particular interest largely because of the low cost of commercially pure urea.

Tin plating, nickel plating, or the use of a tin-lead solder will provide adequate protection against nitriding, if this is desirable.

For best results in nitriding, steels of special compositions should be used. Generally, these fall within the following analysis limits, and are available commercially under the name of *Nitralloy* although many other steels of greatly different analyses can be and are nitrided frequently:

<sup>11</sup> See, for a thorough discussion, *Nitriding Symposium*, Ref. 7 at the end of this chapter.

<sup>12</sup> See, for example, R. P. Dunn, W. B. F. Mackay, and R. L. Dowdell, *Trans. A.S.M.*, **30**, 1942, 776–791; Marx Hirsch, U. S. Pat. No. 1,772,866, Aug. 12, 1930.



FIGURE 494. Metallographic appearance of iron nitride needles in steel.  $\times 100$ . (From *Jalmet Notes*, the Bulletin of the Associated Metallurgical Clubs of the Jones & Laughlin Steel Corporation.)

% C	% CR	% AL	% SI	% MN
0.25–0.50	1.2–1.8	0.9–1.3	0.1–0.3	0.25–0.75

Small amounts of nickel or molybdenum also may be added.

When nitrided steels are used for wear-resisting purposes, they generally are run either against other nitrided steels or against leaded- or graphite-bronze bushings.

#### ELECTROPLATING

The use of relatively thick layers of *hard chromium* plate has prolonged the life of many types of machine parts and tools such as piston rings, plug gauges, cutting and press tools, punches, taps, drills, rolls, molds for die casting and plastics, dies, cylinders, and valves. The combination of hardnesses as high as 600–900 Brinell with the low coefficient of friction of chromium tends to increase the wear resistance appreciably. The process is expensive, but usually proves to be economical in spite of this when all pertinent factors are considered.

In using hard chromium deposits to increase wear resistance care must be taken to avoid or to minimize the effects of hydrogen embrittlement. If this is not done the surface is apt to be broken by the formation of fine cracks which in themselves are not particularly harmful and have little effect on the wear resistance as long as the adherence of the deposit is not influenced but which serve as foci for initiating fatigue cracks and hence actually will accelerate the failure of many types of tools. The usual treatment for removing the embrittling effects of occluded hydrogen is a long-time heating at temperatures under 500 F (260 C); 300–400 F (150–200 C) is the range usually used. This treatment also tends to toughen the deposit somewhat without affecting its wear resistance. Heating to temperatures higher than those indicated, however, will cause an appreciable decrease in hardness.

In moving parts requiring lubrication, such as cylinder walls of Diesel and aircraft engines and piston rings, the use of particular types of *hard matte-chromium deposits* is especially helpful because it gives a bearing surface which is not only hard and wear resistant, but also sufficiently porous to maintain a continuous film of lubricant.<sup>13</sup>

<sup>13</sup> This is discussed in publications of United Chromium, Inc., Waterbury, Conn.

*Wear-Resistant Alloys  
for General Engineering  
Applications*

CARBON RAIL STEELS

A range from about 0.50% carbon to the eutectoid composition is found generally to be most suitable for resisting the form of wear to which railroad rails and similar articles are subjected. Under normal conditions about 5% of the finished rolled steel is made into railroad rails, the most common type being a basic open-hearth steel of approximately eutectoid composition and containing about 0.69–0.82% carbon and 0.70–1.00% manganese. The manganese imparts some wear-resisting properties as well as combining with any sulfur that may be present to form MnS, thus decreasing the amount of FeS and the tendency toward hot-shortness. This is important because these steels are hot-rolled to the final rail shape (cf. Fig. 315).

A metallographic structure typical of this range of compositions is shown in Fig. 495. The pearlite colonies, of a fineness dependent on the rate of cooling following the rolling, may be surrounded by a small amount of free ferrite.

Steels for this application are covered by A.S.T.M. Standards A1 (Standard Tee Rails) and A2 (Girder Rails) the composition range specified depending on the nominal weight of the rail in lb per yd. Similar alloys are used for steel railroad tires (A.S.T.M. Standard A26), and for steel wheels for various purposes (A.S.T.M. Standards A25, A57, A186).

In the "as-rolled" condition, these steels usually will have a strength of about 140,000 psi, with a yield point of 85,000 psi, an elongation in 2 in. and reduction in area of 9% and 12%, respectively, and a hardness of 300 Brinell. Izod impact values of about 2 ft-lb (notched bar), and 20–40 ft-lb (unnotched bar) will be secured, but these values will drop off markedly at subatmospheric temperatures.<sup>14</sup>



FIGURE 495. Metallographic structure of a 0.70% carbon rail steel. Etched with picral.  $\times 500$ . (Photomicrograph by M. C. Fetzer.)

<sup>14</sup>The general subject of "Impact Resistance and Tensile Properties of Metals at Subatmospheric Temperatures" is well covered by H. W. Gillett, *Proc. A.S.T.M.*, **41**, 1941, 5–112.

## INTERNAL STRESSES AND THEIR DETECTION IN RAILS

Rails should be straight after cooling. In order to attain this they must be rolled with a curvature, called a *camber*, because of their irregular section. Consequently, there is a comparatively large amount of internal stress left in them unless the steel is able to yield to it and thus relieve the stress during the cooling cycle. When appreciable residual stresses are present at the same time as dissolved hydrogen, which markedly increases the shatter sensitivity of the steel, minute internal cracks, termed *shatter cracks*, are apt to result. These cannot be detected in their original form, but will in time initiate *transverse fissures*<sup>15</sup> extending through the head of the rail. The rail almost could be severed internally and yet give no visible evidence of an external nature. The development of these fissures, under the action of repeated stresses in service, is a form of fatigue failure.

If these cracks are larger than about  $\frac{3}{8}$ – $\frac{1}{2}$  in. they can be detected by the *Sperry electrical test* which is given by a detector car which passes over the rails periodically.<sup>16</sup> By continuously passing a heavy electric current through the rail in the track, the test magnetically locates and records any impediment to the current flow which exists at the location of a transverse fissure.

The best method for preventing shatter cracks, which usually occur only in about 2% of the rails in regular “as-rolled” material, seems to be the use of a controlled and slow rate of cooling through the range 1200–400 F (650–200 C).<sup>17</sup> This not only permits the rails to deform slowly as the cooling stresses are applied, and thus to relieve or equalize them instead of retaining them as unbalanced internal stresses, but also permits the shatter sensitivity to decrease by the diffusion out of the solid metal of the hydrogen causing it. This shatter sensitivity resulting from the action of hydrogen is not peculiar to rails but occurs in many other types of steels.<sup>18</sup>

## WEAR AND BATTER ON RAILS AND ITS CORRECTION

“Wear” on rails consists not only of the regular wear from wheels passing over them, but also of batter at the rail end when the wheel drops on it as it passes the rail joint. Three methods of minimizing the effects of this batter have been used:

<sup>15</sup> This subject has been thoroughly treated by H. F. Moore in various publications of the University of Illinois Engineering Experiment Station.

<sup>16</sup> See C. W. Gennet, Jr., *Journ. West. Soc. of Eng.*, **45**, 1940, 292–300.

<sup>17</sup> See H. B. Wishart, E. P. Epler, and R. E. Cramer, *Trans. A.S.M.*, **30**, 1942, 592–601.

<sup>18</sup> See, for example, C. A. Zapfe and C. E. Sims, *Trans. A.I.M.E.*, **145**, 1941, 225–261.

1. Elimination of the joints in so far as possible by use of a very long "continuous" rail.
2. Heat-treatment of the rail or the rail ends.
3. Alloying, so the rail will heat-treat itself during normal air cooling.

#### CONTINUOUS RAILS

The standard rail length in this country is 33 ft. Although some users have increased this to 39 ft with an 18% decrease in the number of joints, the real progress in joint elimination seems to lie in the use of continuous welded rails in lengths up to 7000 ft.<sup>19</sup> In these long tracks, not only are rail joints completely eliminated, but creepage is reduced to a minimum. This *creepage* is caused by the wave motion set up along the rail by a moving train and consists of each rail moving ahead slightly, often without closing the rail joint itself. With jointless rails, the rail is elastically compressed ahead of the load and elastically stretched behind it, and the resulting motion is merely an undulation of the rail without lengthwise movement. The fact that there are no joints prevents the joints from yielding, and thus prevents creepage. Likewise, in the continuous rails, thermal expansion forces are held in check by more rigid anchoring of the rails to the ties. The elimination of creepage keeps these joints much tighter than in the usual system. The thermal expansion forces cannot become cumulative because of the rigid holding, and the buckling stresses are absorbed elastically.

Thermit welding has been used most frequently for the welding of continuous rails, although some work with resistance butt welding has been done. The use of electrical methods, of course, would necessitate either preassembly, with special methods of handling the continuous rail, or else a rather cumbersome and expensive means of doing the welding on the job. Up to the present time continuous rails have not been economical to use, largely because of the problems of assembly and installation.

#### HEAT-TREATMENT

Actual quenching and tempering of the rail is usually out of the question because of its length and resulting warpage. However, in short lengths and for some crossover and similar constructions, heat-treatment has been used successfully to secure tensile strengths of 165,000 psi, with yield points

<sup>19</sup> See, for further developments, H. F. Moore, University of Illinois Engineering Experiment Station Reports of the Joint Investigation of Continuous Welded Rail.



of 125,000 psi, 14% elongation, 49% reduction in area, and a Brinell hardness of 300.

However, even on longer lengths various methods, such as continuous cooling furnaces, have been used to normalize and give retarded cooling. Water quenching or spray quenching the rail ends alone, using a water jet, also has been tried, giving Brinells of 400; hardnesses as high as 360 have been secured by use of an air blast. As long as these increases in hardness are not accompanied by too much brittleness, the wear resistance of the rail at these points will be increased.

#### USE OF ALLOYING ELEMENTS

Alloying elements sometimes are added to the steel in order to accomplish the hardening and heat-treatment by means of a simple air-cool following rolling. Thus, by increasing the manganese to 1.20–1.70% the carbon may be decreased to 0.55–0.70%, the lower carbon accompanying the higher manganese within the limits given and vice versa. The high carbon-high manganese combination will not work satisfactorily because it is too brittle. With a properly balanced composition these rails have superior wear resistance and an impact value which, although low, is still about double that of plain carbon rails.

Likewise, suitable properties have been secured by decreasing the carbon content to about 0.25% and adding about 3% chromium. However, this steel is not as yet in wide use commercially, even though it develops excellent properties by a simple normalizing treatment.

#### HIGH-MANGANESE STEEL

*Austenitic manganese steel*, sometimes called *Hadfield's manganese steel* after Sir Robert A. Hadfield who discovered it in 1882, contains 0.95–1.40% carbon, 10–14% manganese, 0.3–1.0% silicon, with phosphorus less than 0.10% and sulfur under 0.06%. Within this range the steel is essentially austenitic with considerable free carbides both in patches and in a network at the grain boundaries. During slow cooling the austenite transforms to martensite as shown in Fig. 496a. However, if the steel is heated to between 1830 and 1920 F (1000–1050 C) the carbides go into solid solution in the alloyed austenite and are retained there on subsequent water quenching. The structure is then completely austenitic similar to that shown in Fig. 496b, and the steel retains a high degree of strength and toughness.

Reheating above 750 F (400 C) increases the brittleness markedly, because of the liberation of some carbides and the partial transformation

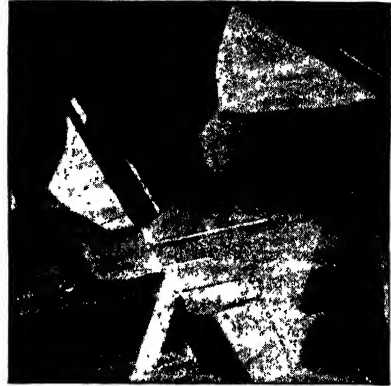


FIGURE 496. Metallographic structures typical of a Hadfield steel (13% Mn – 1.3% C – rem. Fe).

*a. (Upper left)* Cooled slowly from 1850 F (1010 C). Etched with saturated picral.  $\times 500$ . Structure predominantly martensitic with some carbides occurring both at the grain boundaries and as needles within grains.

*b. (Upper right)* Water quenched from 1850 F (1010 C). Etched with picral.  $\times 500$ . Structure completely austenitic.

*c. (Lower)* Water quenched from 1850 F (1010 C), and cold reduced 25%. Etched with picral.  $\times 1000$ . Strain or deformation lines in work-hardened austenite.



(Photomicrographs courtesy U. S. Steel Corporation Research Laboratory, Kearny, N. J.) Original magnifications are given, photomicrographs reduced about one half in reproduction.

of the austenite to a martensitic constituent. This means that reheating after quenching is not satisfactory even though high stresses are produced by quenching. These thermal stresses definitely limit, also, the size of the piece that can be heat-treated successfully, because in sections greater than about 5 in. they begin to produce cracking.

After heat-treatment, the steels can be rolled or forged giving microstructures similar to that shown in Fig. 496c. The resulting strength properties depend largely on the treatment, as indicated by the data on p. 748. In the form of castings the alloy is covered by A.S.T.M. Standard A128.

The good wear resistance of this steel results from its remarkable work-hardening characteristics, especially under conditions in which it is subjected both to heavy pressure and severe abrasion.<sup>20</sup> For applications in

<sup>20</sup> This has been studied recently by D. Niconoff, *Trans. A.S.M.*, 29, 1941, 519–537; *ibid.*, 31, 1943, 716–734.

	TENSILE STRENGTH, PSI	YIELD POINT, PSI	ELONGATION, %
Cast	82,000	45,000	30
Rolled	135,000–140,000	50,000–70,000	40–30
Forged	142,000	55,000	38

which the applied pressures are light or static, the wear resistance is relatively poor because the surface is not work-hardened sufficiently by the low pressure. This work-hardening probably is accompanied by a transformation of some austenite to martensite, with a resultant rapid increase in hardness.

Because of the work-hardening, machining is difficult and can only be carried out with heavy rigid tools, preferably of steel rather than of sintered carbides because of the heavy pressures involved. Drilling may be done best after the alloy has been annealed for several hours at 930–1110 F (500–600 C). Grinding is possible and is the operation used most frequently. The high-manganese steels themselves are not suitable for cutting-tool alloys because of their relatively low yield points.

#### ALLOYED AUSTENITIC-MANGANESE STEELS

Up to 4% nickel is added to the basic Hadfield steel composition either to give increased toughness at elevated temperatures or else, with a lower carbon content of 0.6–0.8%, to serve as a welding rod for the basic alloy. *Nickel-manganese steels* also are used for rolling into rod and drawing into wire, one of their interesting characteristics in this form being that they are rendered ductile by air cooling. Water quenching is not necessary because of the small section.

The addition of 1–1.5% chromium to the high-manganese steels will impart some wear resistance for nonimpact types of loading. This composition is somewhat difficult to manufacture, however, since less cold-work is required to develop the hardened skin than with the chromium-free alloy. The addition of 1–1.5% copper to this alloy tends to increase its ductility, which otherwise is relatively low.

#### APPLICATIONS FOR HIGH-MANGANESE STEELS

The 13% manganese steels containing about 1% carbon, both plain and alloyed, are used extensively for applications requiring a high wear resist-

ance such as railway and trolley frogs, crossings and switches, rock-crusher parts, steam-shovel dippers and teeth, dredge buckets and lips, conveyor chains, sprocket gears and pinions, tractor shoes, and rails for special services, largely in the rolled condition. With the lower carbon content of 0.69–0.82% the alloy also is used for hand tools, forging dies, cutting dies, drills, railroad car wheels, set screws, saws, and structural wire.

Manganese is one of the most useful alloying elements for increasing wear resistance, and by varying the manganese and chromium contents properly, a wide range of properties can be secured. Items such as buckets, bucket parts, dipper teeth, traction links, tread links, and similar parts which are subjected to heavy wear and abrasion usually are made of less expensive materials than the austenite manganese steels, however. Such materials as cast steel, both plain carbon and alloyed, and gray, chilled, and white cast iron are typical of these lower cost materials, the selection of which depends, to a large extent, upon the particular application and the allowable cost.

#### WEAR-RESISTANT CAST IRONS

For wear-resisting purposes, the plain or low-alloy cast irons, either gray, chilled, or white, are used most commonly, the higher alloy cast irons being chiefly used for their heat and corrosion resistance.

The cast irons are a series of alloys usually containing 2.50–3.75% carbon, 0.25–3.00% silicon, and appreciable amounts of manganese, sulfur, and phosphorus. Their structure and properties largely are dependent upon the chemical composition, the rate of cooling, and the foundry practice used. Because different foundries can produce similar properties with greatly different chemical analyses, chemical composition usually is not specified.

#### GRAY IRON

Wide variations in wear resistance may be found in gray cast irons, although, in general, their wear resistance is good and they are used widely for this purpose. The graphite flakes tend to prevent galling, but generally a low-carbon iron with less graphite will give a better combination of resistance to wear and resistance to galling than a high-carbon iron with more graphite. However, the exact significance of this statement depends as much on the application as upon any other factor.<sup>21</sup>

<sup>21</sup> Some phases of this broad field are well covered by O. Smalley, *Metals and Alloys*, **15**, 1942, 256–262, 405–411, 595–598.

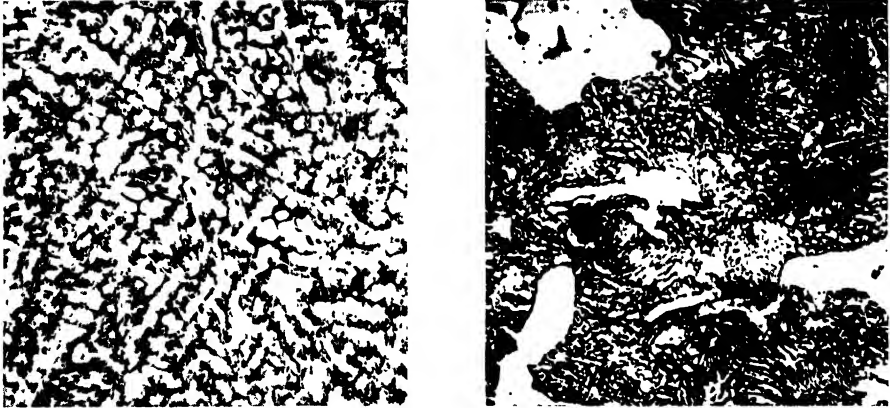


FIGURE 497. Metallographic structure of white cast iron. Etched with nital.  
*a.* (Left)  $\times 50$ , showing dendritic structure. (For  $\times 250$ , showing general structural features see Fig. 238.)  
*b.* (Right)  $\times 500$ , showing details of pearlitic background. (Photomicrographs by L. Litchfield.)

The machinability of these materials also may vary considerably depending upon the composition, structure, and properties. This is illustrated diagrammatically in Fig. 498*a*. With gray cast iron, as a rule, the harder and stronger the casting is, the more difficult it is to machine and vice versa. Graphite assists the machinability materially but also tends to give an open or pitted surface if the flakes are too large.

Gray cast iron is used widely for such purposes as passenger automobile, bus, and truck cylinder blocks, locomotive cylinders, hydraulic press cylinders, pistons, brake drums, gears, flywheels, piston rings, cast-iron pipe and fittings, engine and machinery beds and bases, radiators, grate bars, manhole covers, fireplugs, lamp posts, and many similar applications where excellent combinations of properties and ease of casting are important. The higher strength types, which may be classed more correctly as structural materials, have been discussed previously in Chap. XVI.

Gray iron castings for automotive use, including several applications involving wear, are covered by A.S.T.M. Standard A159. Tentative Standard A190-T (Light Weight and Thin Sections) covers other applications of this type.

#### WHITE AND CHILLED IRON

In white cast iron there is no free graphite and the principal constituents are cementite and pearlite. The metallographic structure will be similar to those shown in Fig. 497. The dark-etching constituent is pearlite into which

the austenite has transformed as it cooled through the lower critical and the light-etching constituent is probably the ledeburite eutectic. Because of the comparatively rapid rate of cooling, the eutectic structure is so fine that it often may etch completely white and thus resemble pure cementite in appearance. If the rate of cooling is more gradual, the fine structure of the eutectic will be resolved.

*Chilled iron* is a gray iron composition which can be controlled to give either a white or gray structure merely by controlling the rate of cooling. By casting it against a metal plate or other *chill*, the surface will have the structure of a white casting, whereas the slower cooling portion in the center will have a gray structure, and the region in between will be mottled. The appearance of these zones in a fracture has already been seen in Fig. 116. Since the rate of cooling will decrease as the distance from the chill increases, the depth of the chill layer can be controlled to some extent by varying the composition of the alloy.

White and chilled cast iron, because of their structure, are very hard and brittle materials, and find few applications except where the hardness is desirable and the brittleness not too important, as for wire-drawing dies, chilled iron rolls for rolling metals, chilled car wheels, cams and cam followers, plow points, abrasive blast nozzles and pump castings, and toys. Most white cast iron is used for malleabilizing.

The white cast irons are superior to the gray irons for conditions requiring the application of high unit loads following which there is relative motion between two members. Such conditions are found for tools used for shaping and forming soft ductile metals, for ball and similar grinding mills, and in applications involving scrubbing or impingement by abrasive materials.

#### WEAR-RESISTING ALLOY CAST IRONS

The hardness and wear resistance of cast iron may be increased appreciably by proper alloying without interfering greatly with its machinability, as illustrated diagrammatically in Fig. 498.<sup>22</sup> This is especially important because, if the hardness is increased in the more obvious manner by increasing the amount of combined carbon, the wear resistance may actually decrease instead of increasing, particularly if the carbide particles tend to fall out. By proper use of the alloying elements: nickel, chromium, molybdenum, manganese, copper, vanadium, and titanium, iron can be hardened more efficiently and more uniformly than is possible by the use of chills alone. The influence of various alloying elements on the depth of

<sup>22</sup> P. D. Merica, *Trans. A.I.M.E.*, **125**, 1937, 13-46, discusses this subject well.

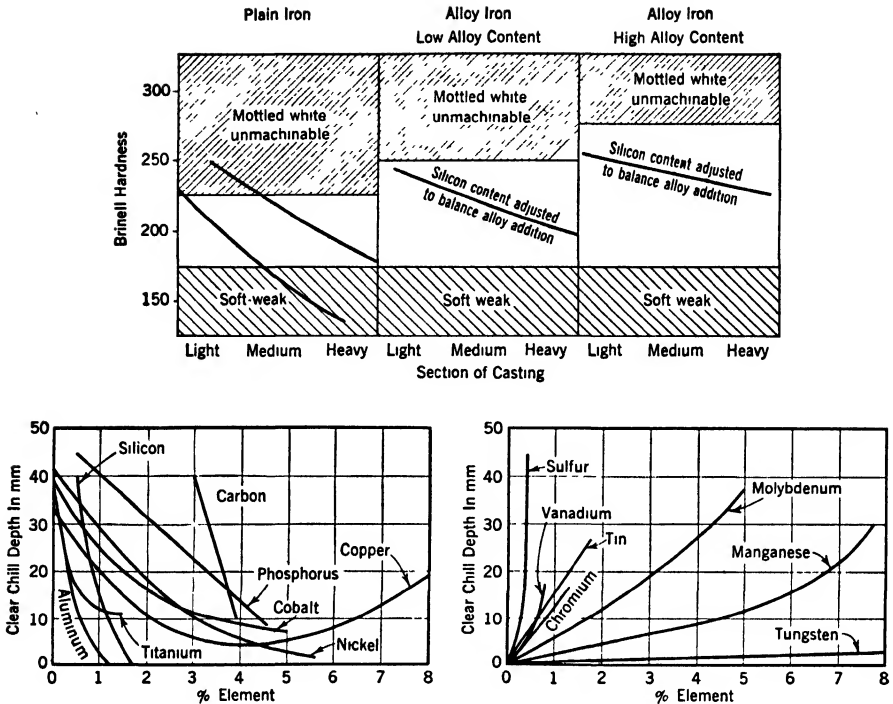


FIGURE 498a. (Upper) Diagrammatic presentation of general effects of alloys in widening range of mechanical properties in cast irons which are pearlitic and at the same time machinable. (From P. D. Merica, *Trans. A.I.M.E.*, **125**, 1937, 2.)  
 b. (Lower) The comparative influence of various elements on the chill depth of a chilled iron roll. *Left*, elements which decrease the depth of chill. *Right*, elements which increase the depth of chill.  
 (From *Cast Metals Handbook*, 1940 ed., courtesy American Foundrymen's Association.)

chill (Fig. 498b) is significant in controlling this process which requires much closer control than generally is realized. The effects of both silicon and nickel already have been shown in Fig. 117.

It has been found by experience that the factor which determines machinability with cast iron is the microstructure rather than the Brinell hardness.<sup>23</sup> Consequently, it is becoming more and more customary to make alloy castings as hard as the application, structure, and shape will permit.

The amount of the various alloying elements that must be used depends to a large extent upon the wear resistance required and the nature of the application. This can be illustrated best by some specific examples.

<sup>23</sup> This is discussed further by J. W. Bolton in *Machining of Metals*, A.S.M., Cleveland, Ohio, 1938.

## CASTINGS WITH LIGHT SECTIONS

Castings which have a light section or an irregular shape can be hardened adequately by the use of small amounts of nickel, chromium, or molybdenum, the total of which seldom exceeds 2%. These additions frequently serve principally to adjust the microstructure, so as to make it fully pearlitic, for example, instead of predominantly ferritic.

Some applications of this type casting include brake drums, camshafts, clutch plates, crankshafts, cylinder blocks, cylinder heads, cylinder liners and sleeves, idler gears, pistons for automotive, Diesel, and gas engines, piston rings, valve stem guides, compressor and pump bodies, frames and cylinders, metal-working dies, railroad castings, and rolls for rolling mills. These low-alloy cast irons comprise the greatest tonnage of castings made predominantly to resist wear.

Although the exact analysis used for a casting intended for any specific purpose will depend as much on the buyer's desires and the foundry's preference as upon any basic specification, castings of this sort generally will have compositions within the limits:

% SI	% T. C.	% G. C.	% C. C.	% MN	% NI	% CR	% MO	% CU
1.5-3.0	2.5-3.5	2.0-3.0	0.3-0.9	0.5-0.9	0-2.0	0.1-1.0	0.2-1.0	0-1.0

As a general rule the alloys will contain less than 0.12% sulfur and 0.20% phosphorus.

Depending upon the microstructure, the tensile strengths of castings of this type may range from 30,000-75,000 psi. They are made to a wide range of specifications for transverse test results.

## CASTINGS WITH HEAVY SECTIONS

Somewhat larger amounts of alloying elements, generally totaling 2-4%, are required when heavy sections must be modified as would be anticipated because of the slower rates of cooling. Increasing the nickel content for a given section will make the matrix pearlite successively finer until it becomes nearly unresolvable at a hardness of about Brinell 250-275. This structure, illustrated in Fig. 499a, is desirable. Increasing the amount of nickel above this, however, will cause martensite to form as the hardness



exceeds 325 Brinell, and the casting may be too brittle unless it is heat-treated properly. Chromium is used largely to decrease the cost by decreasing the amount of nickel required to produce a given result.

Heavier sections would be used for such applications as ore chutes, machine tool beds, automobile body and fender dies, hot-forming dies, and gears. In the heavier sections also, the silicon and carbon would be kept toward the low side of the limits given above.

#### HEAVY-DUTY CASTINGS

Heavy-duty castings, such as used for roll segments, chute plates, jaw crusher plates, roll crusher shells, sandblast nozzles, cams, die casting pots, roller bearing races, and metal finishing rolls, for example, must be made of a fully-hardened chilled or white cast iron with a martensitic matrix. To accomplish this, nickel-chromium additions in the range 4–6% are used, preferably with low-silicon and moderate-carbon contents to decrease the graphitic carbon. One of the better known materials of this type is the alloy *Ni-hard* which will analyze, on the average:

% SI	% T. C.	% C. C.	% MN	% NI	% CR
0.4–1.2	3.2–3.6	3.2–3.6	0.4–1.5	4.0–6.0	1.0–2.5

The composition of these castings will vary depending upon the section dimensions and properties desired.<sup>24</sup>

Specimens of this alloy, with a fully white structure, will have a tensile strength of 35,000–50,000 psi, and with a gray core this may reach 60,000–80,000 psi. In the transverse test, specimens will deflect 0.06–0.08 in. for loads of 4500–6000 lb.

Typical microstructures, shown in Fig. 499*b*, consist of massive carbides in a martensitic matrix as would be anticipated from the above discussion.

The Brinell hardness will range from 600–650, for sand-cast, to 700–750, for chill-cast specimens. By controlling the composition for a given section, castings can be produced which will be hard when sand cast, as well as those that will require chills to produce a given hardness.

For applications requiring a high impact strength, or when some bending may be expected in use, castings usually are heat-treated by soaking at 1650–1700 F (900–930 C) followed by an oil quench and a draw at 400 F

<sup>24</sup> See J. S. Vanick, *Trans. A.I.M.E.*, **105**, 1933, 53–65, for a complete discussion.

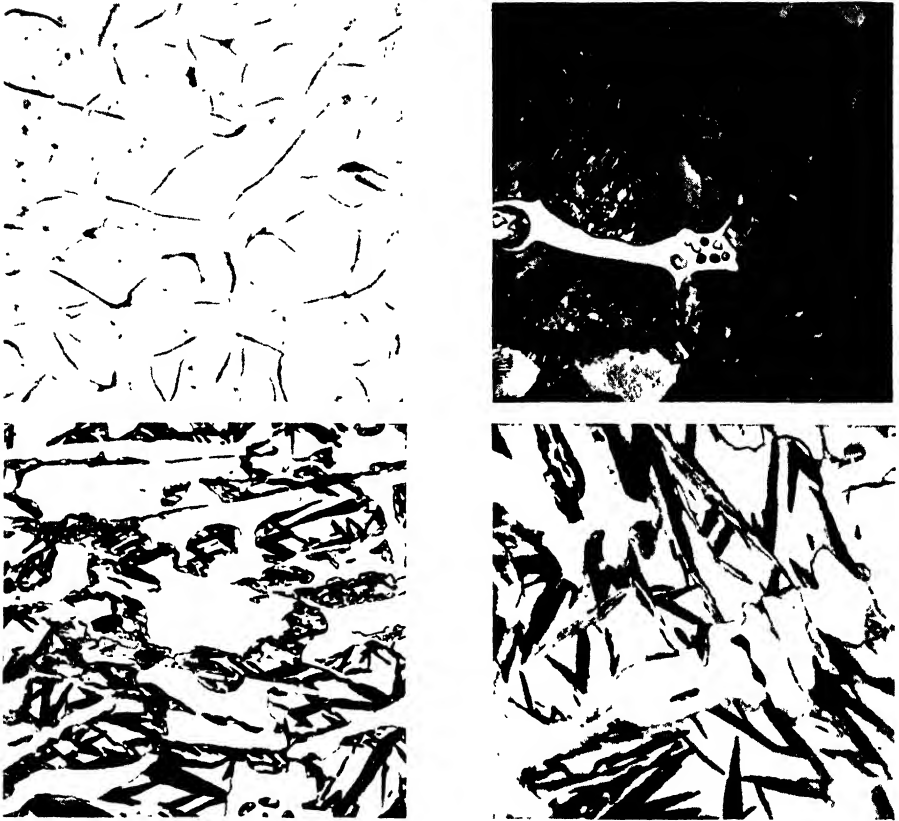


FIGURE 499. Metallographic structures of chill cast irons.

*a. (Upper)* Moderately hardened (2.30% Ni — 0.96% Cr — 1.75% Si — 3.09% T. C. — rem. Fe). Unetched. *Left*,  $\times 100$ , showing appearance of graphite flakes. Etched with 2% nital. *Right*,  $\times 500$ , showing detail of pearlitic matrix.

*b. (Lower)* Fully hardened, Ni-hard types. Etched with nital. *Left*,  $\times 100$ . (4.60% Ni — 1.64% Cr — 1.28% Si — 3.41% T. C. — rem. Fe). *Right*,  $\times 500$ . (4.55% Ni — 1.55% Cr — 0.45% Mn — 0.47% Si — 3.48% T. C. — rem. Fe).

(Photomicrographs courtesy the International Nickel Company, Inc.)

(200 C). After the draw a slow cool should be used. This toughening treatment first partially dissolves and breaks up some of the massive carbides, and then, in the draw, reprecipitates them in a finely spheroidized state.

The cast irons containing 2.0–3.5% nickel and 0.7–1.0% chromium, somewhat below the Ni-hard range, but above the range of compositions used with heavy sections, also give good wear resistance. These castings will have a Brinell hardness about 100–150 points lower than the higher alloy variety because the structure of the chilled face will be essentially fine or nodular pearlite and cementite instead of martensite and cementite. However, these compositions are machined more readily than the higher

alloys since the core is gray and high-speed cutting tools may be used on the chilled face. These compositions find extensive use for car wheels, plow points and shares, and similar applications.

#### BALL AND ROLLER BEARINGS

Alloys for ball and roller bearings require a high degree of hardness and uniformity coupled with *tough-hardness*, some plasticity, and a moderately good machinability.

The most inexpensive material for this application is an S.A.E. 1090 plain carbon steel, which should be in a spheroidized condition for optimum machinability, and then hardened by oil quenching from above the critical range followed by tempering to the desired hardness.

Steels of the S.A.E. 52100 group containing 0.95–1.10% carbon, 1.20–1.50% chromium, and usually with 0.30–0.50% manganese also are among the commoner alloys used. Small amounts of molybdenum or vanadium sometimes are added to increase the hardness. The machinability of this type material can be improved by heating in the range 1400–1425 F (760–775 C) for several hours, depending upon the shape and size, followed by very slow cooling. In the soft condition the Brinell hardness will be below 170. Since these steels are of the pearlitic variety, they may be hardened by quenching in water (1425–1475 F) or oil (1500–1600 F) from above the critical range.

The S.A.E. 6195 steels are of a chromium-vanadium rather than straight chromium type. By the addition of 0.15–0.18% vanadium it has been possible to drop the chromium to 0.80–1.10%. The carbon is also slightly lower, but the general heat-treatment and properties are quite similar to those of the 52100 type. The structure is to all intents and purposes identical.

An alloy of iron with 17% chromium and 1% carbon is used for balls and roller bearings for many applications where corrosive conditions are severe. This is a steel commonly used for forgings requiring high strength and stability, toughness, and high resistance to corrosion, and is discussed more thoroughly in Chap. XV and XVIII. It is much more difficult to handle than the other steels but can be treated easily if the proper temperature ranges are used. In particular it must be remembered that chromium carbides are dissolved less readily than cementite and, therefore, longer soaking times are required than with the carbon steels. Strains induced in quenching or tempering also must be removed carefully or cracking in service may ensue.

For roller bearings in which ductility is required in combination with high hardness and fatigue resistance, steels of the S.A.E. 4340 type, con-

taining about 0.40% carbon, 0.65% manganese, 2.0% nickel, 0.9% chromium, and 0.2% molybdenum have been found to be very satisfactory. This is an excellent example of the use of several alloying elements in small amounts to increase hardenability, even though the brittleness of the alloy is considerably decreased by the low percentage of carbon.

For heavy-duty roller bearings in railroad use, the S.A.E. 4650 steels, containing 1.75% nickel, 0.25% molybdenum, and 0.50% carbon, develop high hardness and strength combined with good ductility and high resistance to notched bar impact when tempered at low temperatures. For this application, the S.A.E. 3312 steels, containing 3.50% nickel and 1.50% chromium, as well as the *modified Krupp analysis*, containing 4.50% nickel and 1.50% chromium, also have been used after casehardening and suitable heat-treatments. They have a high wear resistance and fatigue resistance and give high core strengths because of their air-hardening characteristics. These steels, however, are not machined so easily as many of the others, and require care in heat-treatment, even though they give the ultimate in performance and properties.

The S.A.E. 3415 steels, containing 3% nickel and 1% chromium, will give file-hard cases and high core strengths after carburizing and oil quenching. They have good machining properties for automatic-machine production. The cores also will be very tough, because it is a fine-grain steel used with a single oil quench. Cups, cones, and rollers in casehardened roller bearings, except those of large size, frequently are made of this analysis.

Certain nonferrous alloys, such as 89% Cu—10% Al—1% Fe, a typical *aluminum bronze*, and *Monel metal* sometimes are used for ball bearings in applications requiring corrosion resistance. However, these are not common.

#### ALUMINUM BRONZES

Most of the aluminum bronzes used for applications involving wear resistance are cast copper-base alloys containing 8–9% aluminum and 2.5–3.5% iron, for the softer alloys, or 13.5–14.5% aluminum and 4–5% iron, for the harder alloys. Several intermediate grades also are made.

Centrifugal casting is preferred to sand casting whenever the size and shape of the part make the centrifugal method feasible. Tensile strengths of 60,000–70,000 psi, combined with yield strengths (0.5% elongation) of 22,000–27,000 psi, and elongations and reductions in area of 22–27% can be secured with the softer alloys. These will usually have a hardness of 109–124 Brinell or B61–71 Rockwell. The harder alloys will have tensile strengths of 75,000–85,000 psi, with a minimum yield strength of 45,000

psi and the relatively low elongations and reductions in area of 0–2%. The hardnesses of this modification will be about 321–352 Brinell or C34–38 Rockwell.

As indicated previously in Figure 415, some grades are subject to heat treatment giving tensile strengths as high as 95,000–105,000 psi, with yield strengths of 43,000–50,000 psi, and the comparatively good elongations and reductions in area of 10–15%. Hardnesses in this condition will run 183–207 Brinell or B89–94 Rockwell.

The wear-resisting properties of the aluminum bronzes are probably the result of a combination of metallographic structure and a film of aluminum oxide which tends to form on their surface. Microstructures are, in general, similar to those shown in Figure 415 although high magnification will disclose numerous finely-dispersed particles of a copper-aluminum-iron secondary solid solution phase which is very hard and is an important factor in the alloy's wear resistance.

Most of the cast aluminum bronzes are difficult to machine, although by using suitable feeds and speeds and cobalt high-speed or carbide tools satisfactory results can be secured. Free machining modifications of some of the softer grades also are available.

Some typical applications include cam rollers, leveling rollers, wear strips, plastic extrusion cylinders and plungers, pump parts such as impellers and impeller wearing rings particularly when corrosive liquids or solid particles are likely to be present, forming dies, and deep-drawing dies, especially for use with stainless steel.

Several of the grades are covered by A.S.T.M. Tentative Standard B148-T. The best known of the commercial materials is the *Ampco Metal* series of alloys.

### *For Further Study Refer to*

1. *Metals Handbook*: American Society for Metals, Cleveland, Ohio, 1939 (usually published triennially). A new edition will appear in 1948.
2. *The Making, Shaping, and Treating of Steel*, 5th ed., by J. M. Camp and C. B. Francis: Carnegie-Illinois Steel Corp., Pittsburgh, Pa., 1940.
3. *Steel and Its Heat Treatment*, 4th ed., by D. K. Bullens: John Wiley & Sons, Inc., New York, 1938.
4. *Alloy Cast Irons*: American Foundrymen's Association, Chicago, Ill., 1939.
5. *Cast Metals Handbook*, 2d ed.: American Foundrymen's Association, Chicago, Ill., 1939.

6. *Carburizing Symposium*: Transactions American Society for Metals, Cleveland, Ohio, 1938.
7. *Nitriding Symposium*: American Society for Steel Treating (now American Society for Metals), Cleveland, Ohio, 1929.
8. *Symposium on Furnace Atmospheres for Metallurgical Purposes*: American Chemical Society, Easton, Pa., 1940.
9. *Vanadium Steels and Irons*: Vanadium Corporation of America, New York, 1935.
10. *The Book of Stainless Steels*, 2d ed., edited by E. E. Thum: American Society for Metals, Cleveland, Ohio, 1935.
11. *Copper and Copper Base Alloys*, by R. A. Wilkins and E. S. Bunn: McGraw-Hill Book Company, Inc., New York, 1943.
12. *Metal Progress*: American Society for Metals, Cleveland, Ohio (published monthly).
13. *Materials and Methods* (formerly *Metals and Alloys*): Reinhold Publishing Corporation, New York (published monthly).
14. Publications of:
  - Bethlehem Steel Co., Bethlehem, Pa.
  - Climax Molybdenum Co., New York, N. Y.
  - International Nickel Co., Inc., New York, N. Y.
  - Timken Roller Bearing Co., Canton, Ohio.

## XVIII Tool Materials

### CHARACTERISTICS REQUIRED

**T**OOLS MUST WITHSTAND CONDITIONS WHICH ARE, ON THE whole, more severe than those required of any other type of application. Consequently, they must be made of high-quality materials possessing rather unusual characteristics, some of which are:

1. *Wearing Ability*. High-quality tool alloys are expensive to produce, and must be put through expensive working and treating operations before they can be used. Their high cost can be justified only by a resultant long life and this implies wearing ability or abrasion resistance.

2. *Mechanical Strength and Shock Resistance*. If a tool is to withstand the shocks inherent in all cutting and forming operations, it must be able to absorb both static and impact energy without failure and have a high elastic limit.

3. *Formability*. Since tools have definite shapes and forms, depending upon their intended use, the material from which they are made must be adaptable to changes in shape, usually by machining, by forming, or by grinding. However, once a given form or shape has been secured, it is desirable that this be retained throughout subsequent heat-treating operations.

4. *Hardness*. The tool must be harder than the material it is cutting or shaping, if it is to have a long life. Thus it either must have a high inherent hardness or else must be susceptible to hardening by heat-treatment.

5. *Hardenability*. Since tools are expensive to make, it is essential that waste and spoilage be kept to a minimum. This requires that dimensional changes during hardening either be negligible or else uniform, reproducible, and controllable, and that the hardenability characteristics such as hardness, depth of hardness penetration, and susceptibility to cracking be controllable in a known manner and without the use of complicated techniques.

6. *Heat Resistance*. Since, in shaping operations, energy is released in the form of heat and since many shaping operations are performed at ele-

vated temperatures, it is essential that the tool retain its shape and hardness at the intended temperature of operation.

#### ECONOMIC CONSIDERATIONS

Although tools are expensive, the major portion of their cost arises from the machining operations, the heat-treatments, and the final grindings or lappings which the tool material must be given before it can be used. Consequently, it is desirable to select the best alloy possible without increasing costs excessively and then to use as rigid quality specifications as are required to minimize spoilage and wastage from this source.<sup>1</sup>

Tool life is important; and expensive alloys may be justified entirely, and be cheaper in the long run, if they are worked and heat-treated more easily, and produce tools that give longer service than those made from lower cost materials. However, this does not imply in any sense that expensive alloys of complex composition are necessary for tools. In the majority of cases, in fact, the well-made inexpensive alloys will be entirely satisfactory.

#### TOOL MATERIALS

Because of the characteristics required, almost all tools are made of steel or cast iron, either plain carbon or alloy. Certain types of tools are made from cast cobalt-base alloys containing tungsten; and, for the most drastic cutting, diamonds and sintered carbides, the hardest materials known today, are used extensively. However, except for a few nonsparking tools made from special copper alloys, and certain forming dies for aluminum for which special zinc alloys have been developed, these are the only materials used today for this purpose.

#### *Tool Steel*

Tool steels are of such high quality and are used in such comparatively small quantities that they generally are made only in electric-arc or induction furnaces.

#### EFFECTS OF ALLOYING ELEMENTS

Tool steels are, essentially, combinations with iron of one or more of the elements: carbon (2.45%), silicon (2.25%), manganese (1.75%), chromium (18%), vanadium (2.50%), tungsten (21%), molybdenum (9%), cobalt

<sup>1</sup> This general question is well treated in Ref. 3 at the end of this chapter.



(12%). In each case the number in parentheses indicates the maximum amount of this element that ordinarily is used.

*Carbon*, of course, is the essential element in tool steels since its presence permits them to be hardened sufficiently to function properly. Tool steels are generally either eutectoid or hypereutectoid in nature although carbon contents may be as low as 0.6% for certain purposes.

*Silicon* is found dissolved in the ferrite or the austenite depending upon the temperature. This element will be found in all tool steels since it functions primarily as a deoxidizer. As an alloying element, its effect is to increase the depth of hardening. However, it almost never is used alone because of certain deleterious effects it has on the hardenability characteristics, especially the uniformity of hardness penetration. In high-carbon steels subject to cold-work, such as drill rod, the presence of 0.50% silicon alone will cause the formation of graphite during process annealing. To prevent this, small amounts of chromium generally are added in the melting process to stabilize the carbides. The addition of silicon also increases the wear resistance of the alloy, but only with a concomitant increase in brittleness; and, in combination with manganese, improves the fatigue resistance appreciably, a characteristic which is especially valuable in tools subject to batter.

*Manganese* will be found in all tool steels because of its deoxidizing properties. Although it dissolves chiefly in the iron, hardening and strengthening it at all temperatures, it has some tendency to combine with carbon and be found in the carbides in the treated steel. It is used in tool steels because of its effects on the constitution of iron-carbon alloys, and upon hardenability. It tends to decrease both the carbon content and the temperature of the eutectoid as discussed in Chap. VIII, thereby decreasing the brittleness for an equivalent hardness; and it increases the hardenability appreciably thereby permitting larger sections to be hardened without excessive deformation.

*Chromium* dissolves in both the ferrite and the carbides. It refines the grain and strengthens the ferrite, and it increases the hardness and stability of the carbides. Thus the hardness of the steel is increased without an accompanying increase in brittleness. Its effects in increasing the sluggishness of the austenite transformation and upon the iron-carbon constitutional diagram have already been mentioned in Chaps. VIII and IX.

The principal effects of *vanadium* are somewhat similar to those of chromium. In addition, it serves as a strong scavenger (deoxidizer), and inhibits austenitic grain growth. This latter effect permits a broader safe hardening range but increases the possibility of soft spots. The steels containing 0.25% vanadium are the shallowest hardening of all the water-hardening carbon

tool steels. Consequently, in order to take advantage of this property, it is essential that drastic quenching methods be employed. In the oil- and air-hardening alloys both vanadium and chromium generally are added.

*Tungsten* is essentially a carbide former, increasing the hardness of the steel as well as inhibiting its grain size. It imparts also great stability under heat, giving what is termed *red hardness*, a particular form of heat resistance found in tools. Tungsten almost always is used in conjunction with other alloying elements.

*Molybdenum* dissolves in the ferrite as well as combining with carbon to form a carbide, and with iron to form an intermetallic compound. It is not so strong a carbide former as either chromium or tungsten, however. In solid solution in the ferrite it increases the hardness and affects the critical temperatures. Its use is limited, as a rule, to amounts below 2% because in much greater percentages it tends to volatilize from the steel as the oxide at rolling, forging, and heat-treating temperatures unless salt baths, controlled-atmosphere furnaces, or some protective coating such as borax is used. Molybdenum can be used as at least a partial substitute for tungsten in case of a shortage of that element, but only about half as much molybdenum as tungsten is required in a tool steel to produce comparable properties. However, the resulting steels tend to be susceptible to decarburization and sensitive to grain growth in both manufacture and heat-treatment so the temperature control must be precise. The most marked characteristic imparted by this element is reaction to heat-treatment as it probably produces a greater tendency to air-harden than any other alloying element. Its full benefits are not evident unless it is used in combination with other elements.

*Cobalt* is found dissolved in the ferrite or the austenite, depending on the temperature. This is an unique alloying element in steel in that it apparently increases the rate of austenite transformation and thereby decreases hardenability, i.e., makes a faster cooling rate necessary to secure a fully martensitic structure, instead of decreasing the rate of austenite transformation and increasing hardenability, as most of the other alloying elements do. It is used in tool steels, principally of the *red-hard* type, because of its beneficial effects on the cutting ability at elevated temperatures; and is used, generally, only in combination with other alloying elements which compensate for its peculiar hardenability effects.

#### HEAT-TREATMENT OF LOW-ALLOY TOOL STEELS

The general heat-treatment for most low-alloy tool steels consists of three stages:

1. Heat above the  $A_1$  critical,<sup>2</sup> usually slowly to avoid cracking.
2. Soak, to facilitate the solution of eutectoid carbides and to secure greater austenite uniformity, but only to an extent dependent upon the grain growth characteristics of the steel.
3. Quench either into water, or oil, or else air-cool, depending upon the type of steel and the use for which it is intended.

In the majority of tools, tempering follows the quench to relieve quenching stresses and to give the desired hardness and mechanical properties.<sup>3</sup>

Details of selection and heat-treatment for given applications should be taken up with the tool-steel manufacturers.

#### COLD-TREATMENT OF TOOL STEELS

Refrigeration has been used since about 1930 as a stabilizing treatment for carbon and low-alloy tool steel gauges. Treatment at  $-50$  F ( $-45$  C) for a short time generally will be sufficient to "force" the transformation to martensite of any austenite retained in the original quenching.

The fact that certain more highly alloyed tool steels, notably the high-speed and the air-hardening types, were likely to contain appreciable amounts of retained austenite after the usual heat-treatments indicated that these steels also would respond to this type of treatment. It was found, however, that temperatures of  $-100$  F ( $-75$  C) or lower had to be used with these highly alloyed steels if the transformation was to be forced to completion.

Evidence available indicates that the martensite produced during the cold-treatment is considerably finer than that produced by transformation near room temperature. However, whether this is the factor responsible for the improved productivity of many tools of these types after cold-treatment or whether it is a question of strain relief or some other phenomenon has, as yet, not been established definitely.

#### METALLOGRAPHIC STRUCTURE

Despite the fact that many tool steels contain sizable amounts of alloying elements, the same general metallographic constituents are found in them that are found in plain carbon steels even though the heat-treating temperatures in the two cases might be very different. As would be anticipated from the heat-treatment, both carbon and alloy tool steels generally are

<sup>2</sup> It will be recalled that, for hypereutectoid steels,  $A_2$  and  $A_1$  are identical.

<sup>3</sup> The hardening of tool steels has been well explained by P. Payson and J. L. Klein, *Trans. A.S.M.*, **31**, 1943, 218-245.

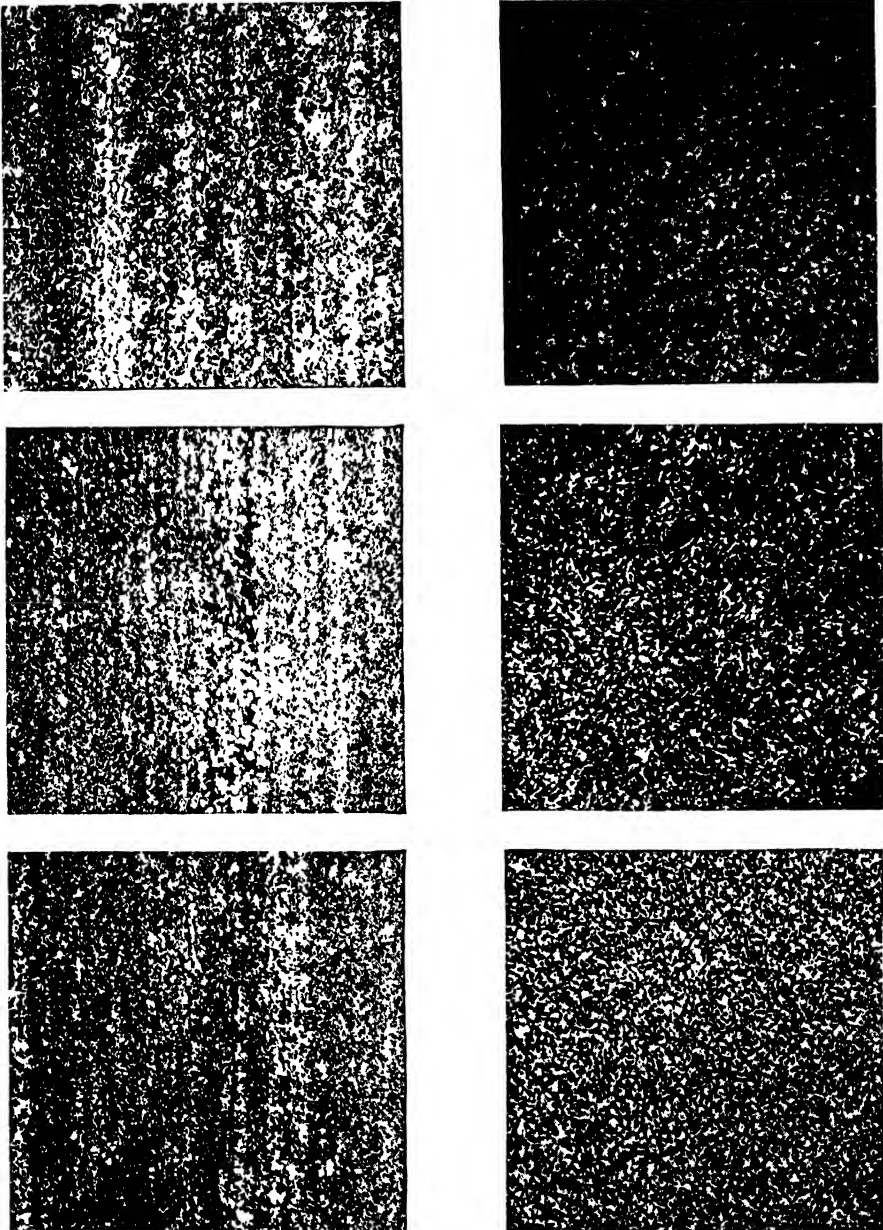


FIGURE 500. Comparison of metallographic structures of a 1% carbon tool steel (*left*) and an 18:4:1 high-speed steel (*right*) after typical heat treatments. Etched with nital.  $\times 100$ . (*Top*) Quenched. (*Middle*) Quenched and tempered. (*Bottom*) Annealed. Note particularly how little of the actual structure can be seen at this magnification.

composed of very hard carbides in a background of tempered martensite. Usually, the former will appear white and the latter dark. Typical structures are illustrated in Fig. 500, where both a 1% plain carbon steel and an 18:4:1 high-speed steel are shown in the quenched, quenched and tempered, and annealed (spheroidized) conditions. In the quenched condition the carbides are found in a light background which is largely unetched martensite with some retained austenite. In the annealed condition, on the other hand, the background in the plain carbon steel structures is mostly ferrite whereas that in the high-speed steel is complex and not thoroughly understood.

### HISTORICAL

*Tools* comprise one of the first uses of steel. Only since about 1860 has steel been used for other purposes. Indeed the origin of the word “steel” itself appears to be lost, and we must infer its beginning by imperfect implications. There is some reason to believe that it was employed first by the ancient blacksmith to describe a form of iron as he witnessed the sparks flying from it on his anvil. The first tool steel probably was not melted as such but may have been carburized during repeated heatings while forging a piece of impure wrought iron. As the tedious process continued, the smith noted the “starry” or “steely” appearance of the hot sparks and then knew, from prior experience, that he finally had produced a “steely” iron which would probably make a good sword. At least, it was true in England that the so-called tools were made of carburized Swedish “muck” bar, and it well can be imagined that tools made of such products were anything but uniform.

Benjamin Huntsman, a watchmaker, despairing in 1742 of such disparities, melted a lot of such carburized bars in a crucible furnace and cast the product into an ingot which then was processed to make uniform tools. Thus was brought into the terminology the term *cast steel* to distinguish it from the carburized bars. This term implied uniformity for decades and, even though all steel used today is cast initially, the term has come down through the years to signify uniform tool steel.

The forerunner of what is today called *high-speed steel* was an alloy developed by Robert Mushet in 1868. This steel averaged 2% carbon, 2.5% manganese, 7% tungsten, 1% silicon, and perhaps up to 0.5% chromium. It was an air-hardening steel although it was termed a *self-hardening* steel in Mushet's time since it would harden fully if laid down in still air after a heating at 1400–1800 F (760–980 C). Its simplicity of heat-treatment was a unique property of this alloy, and, as a matter of fact, the forging and heat-treatment were carried out in one operation. Tools were forged to shape in

the range 1400–1800 F (760–980 C), laid down in still air to cool, and then put directly to work. Tacks still are being made in this country from dies so treated which still perform with remarkable results. A typical tack die steel composition is 2.25% C–2.50% Mn–10.50% W–1.50% Mo–1.00% Si–rem. Fe.

American competitors of the early English Mushet steel, notably Sanderson Brothers and the Midvale Steel Company, developed a steel containing substantial amounts of chromium with low manganese. These two general types formed the basis upon which F. W. Taylor and M. White, in 1890, developed the heat-treatment that finally produced the “red hardness” properties in what is now termed *high-speed steel*.

The mere fact that a high subsequent heat-treatment was employed on a steel normally used, in these early years, in the natural or “as-forged” condition is a remarkable tribute to these investigators. Taylor and White demonstrated clearly that steels of the Sanderson and Midvale types could be heated to temperatures in excess of 2200 F (1200 C) with substantially increased cutting performance whereas steels of the high-manganese Mushet types would perform very poorly when heated to such high temperatures. It is reasonable to suppose that, in the absence of the Sanderson and Midvale chromium steels, the work of Taylor and White might have been a complete failure.<sup>4</sup>

In 1910 the electric-arc furnace began to displace the crucible process for tool steelmaking, and in 1926 the first high-frequency furnaces were placed in operation. Today there are more than a thousand different trade names for tool steels made in this country even though the actual number of basic types is fairly small.<sup>5</sup>

#### TESTING OF TOOL STEELS

It long has been realized that the only reliable test for tool steels is their use in the intended application. However, certain mechanical tests are made, largely to check requirements and uniformity of heat-treatment:

1. *Soundness* is determined as a manufacturing control on the billets by means of the *hot-acid* or *deep-etch test*. For this test smooth disks, usually  $\frac{1}{4}$  in. thick, are immersed in a hot solution of HCl (sp gr approximately 1.08). The time in the solution depends upon several factors,

<sup>4</sup> A. S. Townsend, *Trans. A.S.M.*, **21**, 1933, 769–795, has written an excellent article on this general subject.

<sup>5</sup> *Engineering Alloys*, 1st ed., by N. E. Woldman and A. J. Dornblatt: A.S.M., Cleveland, Ohio, 1936; 2nd ed., by N. E. Woldman and R. J. Metzler: A.S.M., Cleveland, Ohio, 1945, is an excellent reference listing of alloy trade names as is also “*A Directory to Tool, Metal Cutting, and Die Steels, and Sintered Carbides*” by T. W. Lippert: The Iron Age, New York. Tool steels also are listed in Ref. 1 at the end of this chapter.

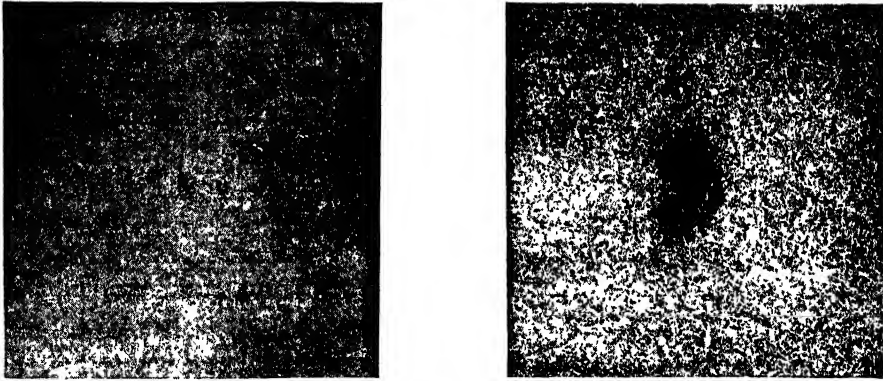


FIGURE 501. Deep etch tests. (*Left*) Uniform macrostructure. (*Right*) Macrostructure showing segregation and pipe. (From *Bethlehem Alloy Steels*, courtesy Bethlehem Steel Company.)

but generally runs between 30 and 45 min. Typical structures are shown in Fig. 501 for a deoxidized steel that is satisfactory, and for a piece showing segregation and pipe. For high-speed steel, the acid test is misleading and it is customary to prepare suitable disks that then are hardened and tempered. In this condition they can be fractured by impact and examined for possible sources of weakness.

2. The quench-hardening characteristics, i.e., *hardenability*, of the steel are tested in a variety of ways, depending upon the manufacturer and customer. Some of these already have been described in Chap. IX. The depth of penetration under certain fixed conditions of treatment is the important factor.
3. *Hardness* is tested by any of the usual methods, or more simply by a sharp flat file. This latter test still is considered to be a very useful one despite its purely qualitative nature. Unfortunately the file test will not detect readily a partially decarburized surface since, as shown in Fig. 263, essentially the same hardness will be developed by quenching in any steel containing more than about 0.60% carbon.
4. The Luerrszen-Greene *torsion impact test* is used to secure specific information about tendency toward brittleness after the various tempering treatments.
5. The *Charpy* or *Izod impact tests* are used as an indication of strength and freedom from brittleness in certain types of tool steels which are subject to shock.

#### CLASSIFICATION OF TOOL STEELS

For simplicity, the general types of tool steels may be considered under three headings, dependent upon the applications for which they are pri-

marily intended: (a) cold cutting and forming; (b) die work; or (c) hot-work.

### *Tools for Cold Cutting and Forming*

#### PLAIN CARBON TOOL STEELS

The plain carbon steels are the best general-purpose tool steels. They may be used for any type of cutting tool or any die for which the size, or the necessity for securing nondeforming, heat-resisting, or other special characteristics, does not require the use of alloying elements. The carbon content is very important in determining the properties of these steels. In general, by decreasing the carbon content shock resistance is increased, and by increasing the carbon content hardness and wearing ability are increased. If the carbon content is increased above the eutectoid range (about 0.80–0.90%) only the wearing ability is increased appreciably and the hardness remains essentially unchanged.

In the annealed condition, both the hypo- and hypereutectoid compositions will have proeutectoid constituents, e.g., free ferrite or cementite depending on the carbon content, but since these are all water-hardening steels, used in the quenched and tempered conditions, this will mean only that steels of either of these carbon ranges will tend to distort more in hardening than those of the eutectoid composition.

Most plain carbon tool steels are manufactured in the range 0.80–1.10% carbon. If the tool does not harden clear through, and this is frequently the case except in small sections, these steels generally will consist of a comparatively hard and brittle case with a core that is fairly soft and shock-resistant. The major constituent of the case will be martensite and of the core a very fine or nodular pearlite. Some control of the hardenability or depth of hardness penetration for a given quenching rate is necessary if reproducible results are to be secured.

The change in mechanical properties of a medium hardening 1.10% carbon tool steel with increasing tempering temperature (frequently termed *drawing temperature*) is indicated in Fig. 502.

Steels of this type have a satisfactory wear resistance, if properly heat-treated and used, a relatively high tendency to warp in heat-treatment, and no red hardness. Some of the better known American brand names for them include: *Bethlehem X, XX, and XXX, Channeller, Comet, Colonial No. 14, Red Star Tool, Electrex, Silver Star, Sterling XX and V, Washington, Lion, Chippaway, Dacar, Centaur, Miner's Drill, Heller's Purple, White, Green and Blue Label, No. 11 Special, Green Label Drill Rod, and the Extra,*



*Special*, and *Standard* types of several brands among which are *Columbia*, *Sanderson*, *Crescent*, *Pompton*, and *Cyclops*.

The addition of about 0.25% vanadium decreases the tendency to grain growth, giving a fine-grained steel that will harden with a shallow case and be apt to have soft spots. Otherwise the carbon-vanadium steels are subject to the same variables as the plain carbon steels although they are also somewhat harder for a given carbon content. Among the commercial tool steels of this modified type are: *Bethlehem Best* and *Superior*, *Colonial No. 7*, *Columbia Standard Vanadium* and *Extra Vanadium*, *Alva Special* and *Extra*, *Heller Yellow Label*, *E. 25*, *Vulcan Crucible*, and *Draco V*.

As might be anticipated, the field of usefulness of the plain carbon tool steels depends on the carbon content. This can be shown best by specific examples.

*Carbon: 0.65–0.80%* Tools requiring a comparatively high shock or batter resistance, such as: shear blades, hammers, stamping and pressing dies, mining drill steel, battering tools, cold chisels, blacksmith tools, solid and hollow rock drills, rivet busters, screw-driver blades.

*Carbon: 0.80–0.95%* Tools requiring shock resistance combined with some wear resistance and cutting ability, such as: auger drills, engraver's chisels, asphalt cutters, nail sets, cold punches, scrapers, cold-swaging dies, knives, reamers, sheet-forming tools, swages, tongs, pneumatic stone chisels, nut and bolt heading dies, cold-heading dies, deep-drawing dies, rivet dies, lathe centers, and wood augers.

*Carbon: 0.95–1.10%* Tools requiring wear resistance and cutting ability combined with some ability to resist shock, such as: cold-forming dies, finishing cutters, pipe cutters, cold-trimming dies, embossing dies, stamping dies, forming tools, cold-shear knives, ring gauges, roll-threading dies, and rock cutters.

*Carbon: 1.10–1.30%* Tools requiring a comparatively high wear resistance and cutting ability, such as: boring tools, woodworking tools, coining dies, adjustable threading dies, pipe-threading dies, center drills, twist drills, milling cutters, planer tools, rifling tools, taps, turning tools, hand stone chisels, automatic-machine tools for nonferrous metals, drawing dies, finishing cutters, rotary slitters, roll-turning tools, scale pivots, and razors.

#### TEMPER COLORS

The carbon tool steels frequently are tempered by heating them until their surface assumes a certain color rather than by heating to a definite temperature. *Tempering by color* generally is not recommended but, when done, it is advisable first to remove all the prior scale from some convenient

area on the tool. The resultant tempering temperature then can be judged closely from the color formed on the cleaned metallic surface.

Sometimes tools even are *self-tempered*, by quenching the cutting portion and then letting the heat from the hot unquenched portion flow back into the quenched portion until the desired surface color is attained. This is not a method of high reproducibility although in many cases it may be entirely suitable.

The temper colors depend not only on the temperature but also on the time of heating, and result from the different thicknesses of oxide films produced at the different temperatures. The approximate relationship between the color and temperature is indicated in Table XLIV.

TABLE XLIV APPROXIMATE RELATIONSHIP BETWEEN TEMPER COLOR AND TEMPERATURE FOR STEEL

TEMPER COLOR	CORRESPONDING APPROXIMATE TEMPERATURE	
	F	C
Faint yellow	430	220
Straw yellow	460	240
Dark yellow	480	250
Brown	500	260
Red-brown	510	265
Light purple	530	275
Dark purple	550	290
Blue	560	295
Dark blue	570	300
Pale blue-gray	600	315

It should be emphasized that, although this relationship is by no means exact, under reproducible conditions it will give fairly consistent results with plain carbon steels. The presence of alloying elements tends to decrease its reliability appreciably.

#### HIGH-CARBON, LOW-TUNGSTEN TOOL STEELS

Steels in the high-carbon, low-tungsten group tend to have a wear resistance somewhat greater than that of the plain carbon steels. They contain about 0.90–1.30% carbon, 0.20–0.40% silicon, 0.15–0.30% manganese, along with about 1.25–2.50% tungsten, and sometimes 0.10–0.25% vanadium. Certain of them are apt to be somewhat erratic in heat-treatment.

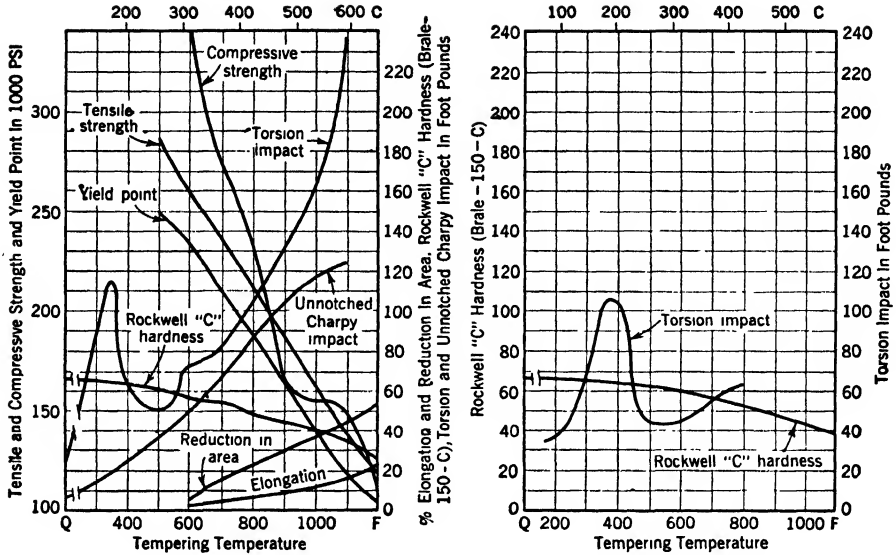


FIGURE 502. (Left) Effect of tempering temperature on some mechanical properties of a medium-hardening carbon tool steel, containing approximately 1.10% C - 0.25% Mn - 0.25% Si - rem. Fe, after water quenching from 1425 F (775 C).

FIGURE 503. (Right) Effect of tempering temperature on some mechanical properties of a high-carbon, low-tungsten type tool steel, containing approximately 1.25% C - 1.50% W - 0.25% Si - 0.25% Mn - 0.70% Cr - 0.25% Mo - 0.20% V - rem. Fe, after water quenching from 1475 F (800 C).

However, any tendency toward soft spots largely can be corrected by the addition of 0.35-0.75% chromium to retard the austenite transformation, and thus permit greater leeway in heat-treatment.

The higher carbon (above 1.15%) steels containing chromium are oil-hardening, although all steels of this type generally can be water-hardened without difficulty or danger of cracking. They have a medium wear- and shock resistance, with low warpage and are medium deep-hardening. They have no red hardness.

As illustrated in Fig. 503, these steels will have higher hardnesses for a given drawing temperature than those of the plain carbon classifications, and are essentially cutting tools. Hence they find their widest use for taps, reamers, and similar tools. Because of their high hardness they usually cut very smoothly, and are suitable for finishing even hard materials provided slow speeds and feeds are used. They often are used also for finishing tools for nonferrous materials, and for drawing dies, blanking dies, and cold-striking dies when wear—rather than shock—resistance is required. Some of the commercial brand names are: *No. 67 Tap*, *Red Star Tungsten*, *Tap*

*Die, Champion Extra, Liberty, Special Alloy 51V, Utica, Para, and Vulcan Hardrite.*

If the carbon content is increased to 1.2–1.4% and the tungsten content to 4–6%, better wearing properties will result but with a lower shock resistance and a higher warpage. Keeping the tungsten around 4%, however, gives a somewhat greater shock resistance. These compositions also tend to show soft spots and are apt to graphitize on prolonged heating. The addition of chromium in the range of 0.40–1.50% helps to eliminate both of these defects, as well as to decrease the warpage somewhat. *K-W, Colonial No. 4, Columbia, Crescent and Sanderson Double Special, R. T. Steel, Fast Finishing Steel, Finishing (Cr, W), and Saturn*, are some of the commercial brand names under which tool steels of this modification are sold.

#### SILICON-MANGANESE PUNCH AND CHISEL TOOLS

The silicon-manganese steels which have been so successful as springs have been used also as an inexpensive steel for cold-cutting, especially when shock or batter resistance is desired. These steels contain about 1.75–2.25% silicon, 0.60–0.90% manganese, and 0.50–0.70% carbon, the higher carbon contents giving the greater hardness. All of these high-silicon steels are liable to soft spots and grain growth in heat-treatment although this can be prevented by adding 0.20–0.35% chromium to slow down the transformation rate, and 0.15–0.30% vanadium to inhibit grain growth. They also tend to decarburize on the surface, a serious fault if they are not to be reground afterward. The addition of small amounts of chromium and vanadium increases the hardness, and, therefore, enables the carbon to be kept on the low side of the range given. If still greater hardenability is desired, it can be secured by adding 0.40–0.60% molybdenum instead of the chromium and vanadium. However, in these harder compositions the high silicon tends to produce brittleness even though it also confers wear resistance. *Omega, No. 71, Silman, Duredge Chisel, Multole Punch, and 67* are some of the commercial brands of this type. Figure 504 indicates the change in mechanical properties with tempering temperature.

The objectionable brittleness caused by high silicon can be overcome by decreasing this element to 0.75–1.25%. The manganese should be decreased simultaneously to 0.35–0.60%, and 0.20–0.40% chromium and 0.40–0.60% molybdenum should be added. This gives the steel a greater shock resistance with nearly the same hardness. The decrease is in the wearing characteristics. *Solar, D-29, and Venango* are among the tool steels of this type.

The basic types of these steels generally are classed as water-hardening

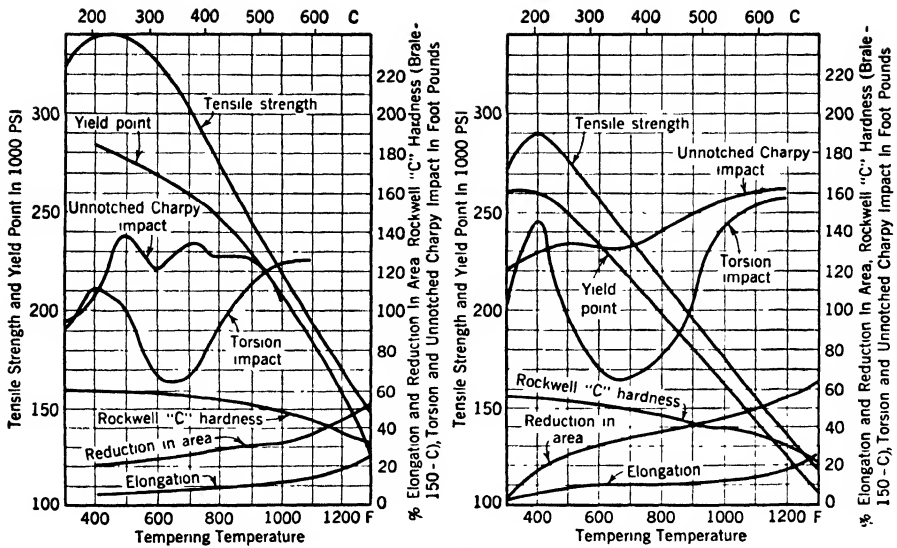


FIGURE 504. (Left) Effect of tempering temperature on some mechanical properties of a silicon-manganese type tool steel, containing approximately 0.60% C - 2.25% Si - 0.50% Mo - 0.80% Mn - 0.25% V - rem. Fe, after oil quenching from 1600 F (870 C).

FIGURE 505. (Right) Effect of tempering temperature on some mechanical properties of a low-chromium-vanadium type tool steel, containing approximately 0.50% C - 1.40% Cr - 0.20% V - 0.25% Mn - 0.25% Si - rem. Fe, after water quenching from 1575 F (860 C).

although many of the modifications with greater hardenabilities can be oil-hardened from somewhat higher temperatures. They are considered to have medium wear resistance, strength properties, warpage, and hot-hardness, and are medium deep-hardening. They tend to have low impact resistance, and low elongation and reduction in area. However, they will give about three times the life of a 1% carbon tool steel when used for chisels, punches, and shear blades, or similar applications for which a comparatively low-cost steel with a shock or batter resistance somewhat greater than that of the plain carbon steels is desired.

#### LOW-CHROMIUM AND CHROMIUM-VANADIUM TOOL STEELS

The addition of 0.10–0.50% chromium, in combination with the usual 0.15–0.50% silicon and 0.10–0.35% manganese, to a steel containing 0.50–1.40% carbon is valuable in correcting the tendency toward soft spots by delaying the transformation of austenite. The higher amounts of chromium also give a more intense hardness. These steels are all water-hardening, but have a relatively low wear resistance, a high warpage, and no red hardness.

Among the commercial tool steels of this type are: *Water Die*, *Art Die*, *Crescent* and *Atha Rim Roll*, *C.F.S. (Die Steel)*, and *Crow*. In addition *Nivan*, *96KC*, and *139B* are similar steels but with somewhat different characteristics because of the presence of about 1.5% nickel.

If the chromium is raised to 0.60–1.40% and 0.10–0.20% vanadium is added, a steel is secured which will oil-harden in thin sections. If, in this higher chromium steel, the manganese is increased to 0.40–0.60%, an oil-hardening steel will be secured thin sections of which are liable to crack if hardened in water. *Tough "H," "M," and "S" Temper*, *ZN*, *R.D.S.*, *Krovan*, *Pyro (Hot Die)*, *89MC*, *Arrow*, *Crown*, *Albany*, *Caroga*, *Titus*, and *Orion* are commercial tool steel brand names for alloys of this type.

Although these steels have somewhat better mechanical properties than plain carbon steels of similar carbon contents, as indicated in Fig. 505, their main advantage lies in a freedom from soft spots and a deeper case, combined with a somewhat greater shock resistance and a lower warpage for the higher alloy members.

## *Die Steels*

### MANGANESE NONDEFORMING DIE STEELS

The manganese nondeforming die steels are one of the three most widely used types of tool steels. They contain about 0.85–1.00% carbon, with 0.20–0.40% silicon, and generally about 0.10–0.25% vanadium. To this base is added 1.50–1.75% manganese. The manganese not only lowers the critical range, thereby permitting a lower hardening temperature for small sections, but also allows comparatively large sections to be given quite a high hardness. This is a definite advantage for large dies. The steels are, however, susceptible to grain growth and are apt to crack in hardening. Vanadium is added to overcome the tendency to grain growth. The addition of 0.20–0.35% molybdenum tends to increase the hardenability, but the breakage tendency will still be present because of the high hardness. *Stentor*, *Paragon Oil Hardening*, *Jessop Special Oil Hardening*, and *Deward* are steels of this type.

If the manganese content is lowered about 30 points to the range 1.10–1.45%, and chromium and tungsten are added in amounts of 0.30–0.60%, the tendency to brittleness and breakage is largely overcome, but at some sacrifice of hardness. If the manganese is lowered still more to the range 0.90–1.15% and the chromium is increased to 0.50–0.90%, the steel will have little tendency to crack in hardening, but cannot be hardened quite so much. Many common American brands of tool steels such as: *Tool Room*

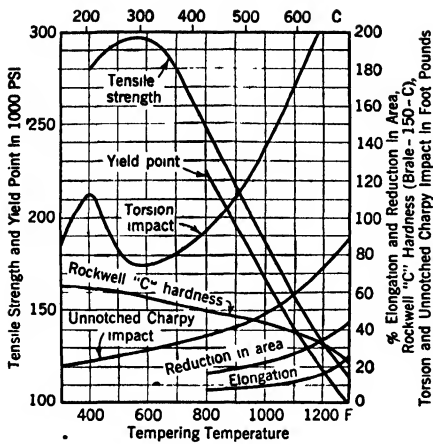


FIGURE 506. Effect of tempering temperature on some mechanical properties of a manganese nondeforming type of tool steel, containing approximately 0.90% C - 1.10% Mn - 0.45% Cr - 0.45% W - 0.20% V - 0.30% Si - rem. Fe, after oil quenching from 1475 F (800 C).

changes during hardening. However, they have no red hardness.

Steels of this type are used widely for general-purpose tools, such as stamping and trimming dies, punches, thread-rolling dies, special taps. They also are adapted well for tools, such as Bakelite-molding dies, master tools, gauges, and blanking dies, which cannot be ground after hardening and for which, consequently, nondeforming characteristics are important.

#### HIGH-CARBON, HIGH-CHROMIUM DIE STEELS

Steels of this type, containing 12-17% chromium, are characterized by a very high wear resistance, appreciably greater than that of the manganese nondeforming steels.

The straight 1.90-2.35% carbon, 12-17% chromium types are oil-hardening and have remarkable wear-resisting properties. However, they are somewhat difficult to machine in the annealed condition. The addition of about 1.0% molybdenum gives these steels air-hardening properties. Sometimes 0.50-0.75% nickel also is added to increase shock resistance somewhat but the machinability tends to be adversely affected because the hardness after annealing is increased also. A similar effect, but without the decreased machinability, may be secured by adding 0.75-1.0% vanadium and sometimes 0.60-1.0% cobalt as well. Machinability can also be improved to some extent by annealing thoroughly and giving a slightly coarsened grain size.

*Oil Hardening, Kiski, Colonial No. 6, Exl-Die, Champion Non-Changeable, Mansil Oil Hardening, Invaro Oil Hardening, Ketos, Truform, Mangano Special, Saratoga, Constant, and Wando* are of these general types.

Mechanical properties typical of these steels are shown in Fig. 506, although these will be affected somewhat by the size of the piece hardened. All of these steels are oil-hardening and usually will tend to crack if water-hardened. They have a low wear resistance, a medium shock resistance, and are medium deep-hardening. Warpage is low and they are classed as *nondeforming*, because of their low dimensional

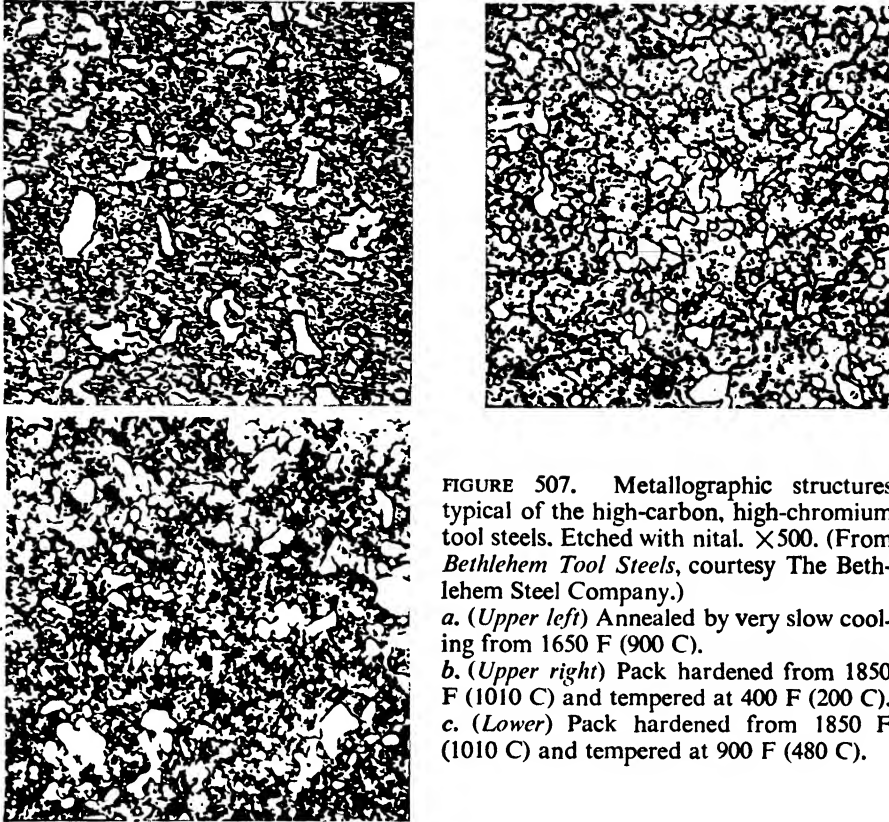


FIGURE 507. Metallographic structures typical of the high-carbon, high-chromium tool steels. Etched with nital.  $\times 500$ . (From *Bethlehem Tool Steels*, courtesy The Bethlehem Steel Company.)

a. (Upper left) Annealed by very slow cooling from 1650 F (900 C).

b. (Upper right) Pack hardened from 1850 F (1010 C) and tempered at 400 F (200 C).

c. (Lower) Pack hardened from 1850 F (1010 C) and tempered at 900 F (480 C).

Lowering the carbon to 1.10–1.75% decreases the wear resistance somewhat but substantially improves the machinability in the annealed condition. Molybdenum, in amounts of 0.50–0.60%, sometimes is added to these alloys along with 3–4% cobalt. This appears to add some “red-hardness” properties and is used when an improved cutting ability is desired. Vanadium also seems to harden the steel and usually is added in conjunction either with molybdenum alone or with molybdenum and about 0.50% cobalt.

The common commercial brands of the air-hardening tool steels of this type include: *Lehigh Die and Tool “H” Temper, Superior No. 3, 610 Air Hardening, Ohio Die, Haldi, Marathon, Croloy, Cromovan, C.N.S., G.S.N. Special, Ontario, CCA, Chromoco, Ultradie No. 2, and Alidie*. Among the oil-hardening types are: *Lehigh Die and Tool “S” Temper, Superior No. 1, Triple Die Steel, 812 Die Steel, 3C, G.S.N., Huron, Ultradie No. 1, Crocar and Hi-Pro*.

Because of their high chromium content these steels differ from the usual structural pattern of tool steels. They are composed of a heavy segregate,



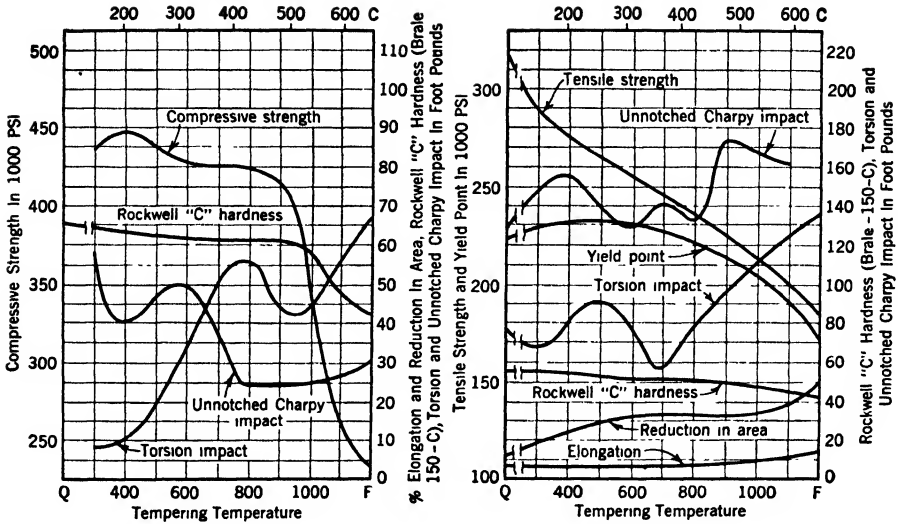


FIGURE 508. (Left) Effect of tempering temperature on some mechanical properties of a high-carbon, high-chromium type of tool steel, containing approximately 1.60% C - 12.90% Cr - 0.75% Mo - 0.25% V - 0.35% Mn - 0.45% Si - rem. Fe, after cooling in still air from a 3-hr pack-hardening treatment at 1850 F (1010 C).

FIGURE 509. (Right) Effect of tempering temperature on some mechanical properties of a tungsten-alloy type of tool steel, containing approximately 0.50% C - 2.40% W - 1.50% Cr - 0.15% Si - 0.25% V - 0.25% Mn - rem. Fe, after oil quenching from 1700 F (930 C).

probably iron-chromium carbides, surrounded by, or imbedded in, a ferrous matrix containing dissolved chromium and carbon. The segregate can be broken up only by mechanical work, and in amount is dependent on both the chromium and carbon contents. Typical structures are shown in Fig. 507.

The impact values of all high-chromium steels are low, as indicated in Fig. 508, although the air-hardening types are somewhat better than the oil-hardening types. The wear resistance is high and the warpage low. They are deep-hardening and will harden throughout in almost any section likely to be used for a die. Care must be taken, however, to avoid a soft skin as they have a very high carbon content and are apt to decarburize.

Their high resistance to wear, nondeforming nature, and air- or oil-hardening characteristics adapt them for use for a wide variety of tools for which wear resistance is desirable, such as dies for blanking, drawing, coining, forming, thread-rolling, or trimming, and for shear blades, punches, lathe centers, guides, and mandrels. As a rule they are not used for cutting tools for ferrous metals although their high abrasive resistance makes them very satisfactory for cutting nonferrous metals. In such cases the frictional heat generated is dissipated by the nonferrous material being cut

and does not build up in the cutting edge of the tool. Because of the high wear resistance of the tool and the relatively high thermal conductivity of the metal being cut, red hardness, which these steels lack, is not needed.

#### TUNGSTEN-ALLOY CHISEL AND PUNCH STEELS

The original steel of this type was known as 1:1:1 because it contained 1% each of tungsten, chromium, and silicon, as well as about 0.50% carbon.

By increasing the amount of tungsten and raising the chromium to the range 1–2% it was possible to eliminate the silicon and still retain the wearing properties. The addition of 0.10–0.30% vanadium increases the fatigue resistance, and helps to retain a fine-grained structure.

This steel can be bent without breaking even when hardened to Rockwell C55–57. Typical mechanical properties for various drawing temperatures are shown in Fig. 509. Steels of this type are oil-hardening, with a medium wear resistance and a high strength and shock resistance. Although they have low warpage they are not nondeforming, and hence seldom are used for dies where this characteristic is of importance. They are medium deep-hardening, and have medium machinability. Among the commercial brand names for them are: *Vibro, Tungo, Buster, Atha Pneu, Crescent Special Alloy Chisel, Keystone Alloy Chisel, J. S. Punch & Chisel, Halcut, Excelo, Heller Orange Label Chisel, No. 67 Chisel, Top Notch, X.L. Chisel, Seminole, Alco, and Par Exc.*

These steels are used most frequently for punches, chisels, shear blades, and battering tools. When abuse is severe they often will last three times as long as plain carbon tools. They have a limited use for dies for hot-work, where they are not heated to any extent or where the dies can be water cooled, such as for heading dies for square-headed bolts or for various types of forging dies.

#### *Tools for Hot-Work*

##### CHROMIUM DIE STEELS FOR HOT-WORK

Steels of this type contain 0.85–1.00% carbon and 3.25–4.25% chromium. This gives an air-hardening steel which is apt to crack in oil quenching if the chromium is near the high side. Dropping the carbon to 0.65–0.75% gives a steel which is adapted better for oil-hardening with the higher chromium content, but which is not so rigid nor so resistant to deformation at temperatures of about 500 F (260 C) as those with the higher carbon. The addition of about 0.40–0.60% molybdenum increases the air-hardening characteristics appreciably. This composition can be hardened so greatly

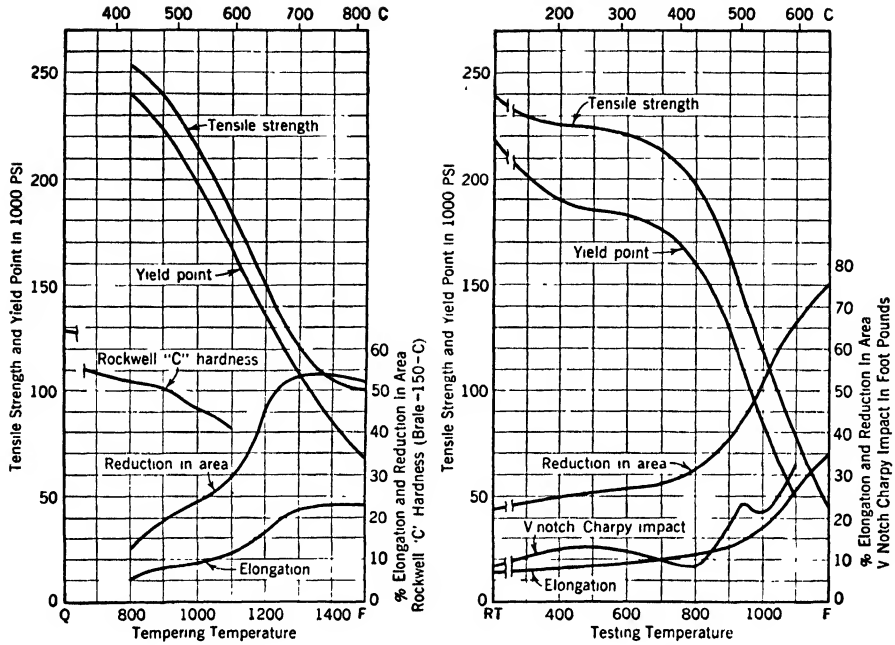


FIGURE 510a. (Left) Effect of tempering temperature on some room-temperature mechanical properties of a chromium die steel, containing approximately 0.90% C - 3.60% Cr - 0.25% Si - 0.25% Mn - rem. Fe, after oil quenching from 1650 F (900 C). b. (Right) Elevated temperature properties after oil quenching from 1650 F (900 C) and tempering at 900 F (480 C) to a Rockwell hardness (measured at room temperature) of C50.

by cooling in air that in many cases a much higher drawing temperature must be used than for the other compositions discussed. *Colonial No. 35, Hot Die No. 2, No. 445 Hot Work, Phoenix, Crescent Hot Work No. 2, Labelle No. 89, H.R.W., C.Y.W., Heller Brown Label, J (and JJ) Hot Working Die, EB Alloy, Bolt Die Regular, Ajax, Choice, and Extra Chrome* are among the American steels of this type available commercially.

Mechanical properties typical of the steels without molybdenum are shown in Fig. 510. The facts that they can be air-cooled, are deep-hardening, and show a considerable rigidity to deformation at moderate temperatures adapt them for dies which do not become heated to more than about 500-600 F (260-315 C) in use. They have medium wear resistance and strength, and low warpage both on oil-quenching and on air-cooling. In the range in which they often are used, viz., hardnesses in the vicinity of 400 Brinell (Rockwell C41), they can be machined but with some difficulty.

Steels of this type are quite brittle in the fully hard condition, and hence, even though they usually are not used in this condition, are not particularly adapted for dies which involve more than a relatively small amount of

shock or which may become heated to a visible red heat in operation. Their largest use is for gripper dies for hot-heading round-headed rivets or bolts, for compression and hydraulic riveters, or for many types of bending dies for hot-work up to 600 F (315 C).

#### TUNGSTEN DIE STEELS FOR HOT-WORK

Several steels that are satisfactory for hot-working operations up to 1100 F (595 C) contain 0.25–0.60% carbon, 8–19% tungsten, 2.5–4% chromium, and 0.30–0.60% vanadium. The hardenability of these steels tends to be high, but this is dependent to some extent upon the carbon content, and to a lesser extent upon the chromium and the tungsten. Also, the higher the carbon the greater the brittleness, as a rule. The red hardness depends largely upon the tungsten content so the steels are not recommended for use above 1000 F (540 C) if the tungsten is less than 12%. Chromium on the high side tends to give good hardenability and high hardness but also tends to increase the brittleness. The vanadium apparently adds some fatigue resistance and some ability to withstand elevated temperatures without softening. Some of the common commercial steels of this type are: *Formite, No. 57 Hot Work, T-Alloy, T-K, Colonial No. 3, Peerless A, B, C and D, Halcomb Hot Work, D.Y.O., 2B Hot Working Die, E.H.W. Nos. 1, 2 and 3, Atlas A and B, Nut Piercer, B-4, Marvel, and Calo Ferro*. Typical mechanical properties at elevated temperatures are shown in Fig. 511.

These steels are in many respects similar to the high-speed steels. They are of a highly segregated nature and generally have a fine fracture; but with the carbon near the low side of the range and the tungsten near the high side, the ingot tends to have an extremely coarse columnar structure which may not be broken up entirely by forging or rolling operations. Because of the deep-hardening characteristics, any heat checking on the surface is likely to lead to deeper cracking or even fracture of the die. The steel also is prone to crack if water-cooled in operation so this should be avoided.

The steels are air- or oil-hardening, with medium wear resistance; and show much less tendency toward erosion at temperatures in the vicinity of 1000 F (540 C) than the other types of hot-working die steels. They have low warpage and high red hardness. Since they carburize readily they should not be packed in a carbonaceous material during heat-treatment, as their mechanical properties depend upon a low carbon content. Air cooling gives a good shock resistance but is objectionable because of a heavy scale formation.

Steels of this type are used widely for dies for the hot-forming of metal, such as forging dies for brass, and for many types of punches and shears for hot-work. They also are used to some extent as dies for the die casting

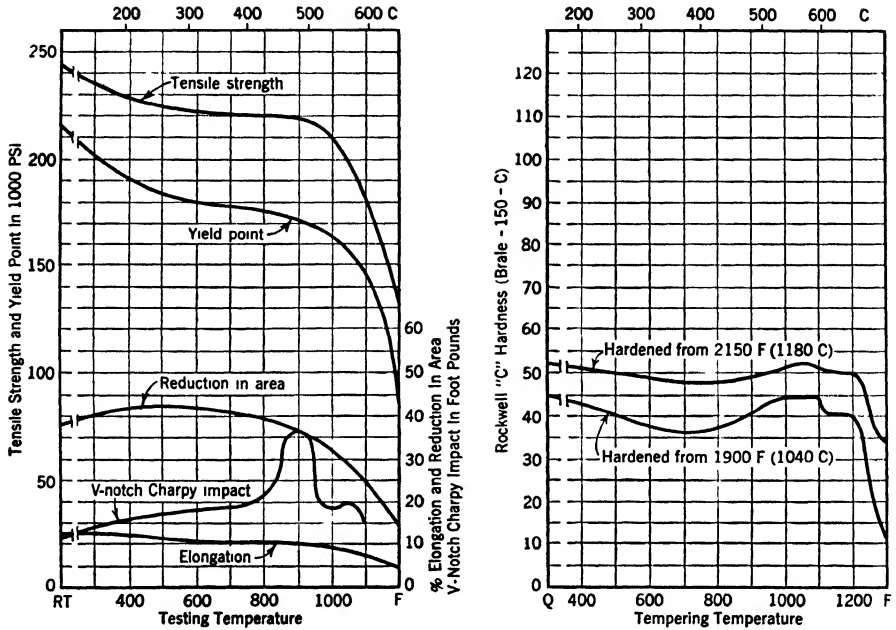


FIGURE 511a. (Left) Effect of temperature of testing on some mechanical properties of a tungsten die steel, containing approximately 0.30% C - 9.75% W - 3.00% Cr - 0.50% V - 0.30% Mn - 0.30% Si - rem. Fe, after oil quenching from 2150 F (1175 C) and tempering to a Rockwell hardness of about C50.

b. (Right) Effect of tempering temperature on the surface hardness after oil quenching from 1900 F (1040 C) and 2150 F (1175 C).

of aluminum, and for permanent-mold castings of brass and bronze. When the tungsten, chromium, and vanadium are kept near the high side they are used for dies for extrusion of brass, and for many types of forming and blanking dies which are apt to become fairly hot in operation.

#### TUNGSTEN-CHROMIUM DIE STEELS FOR HOT-WORK

The use of tungsten-chromium steels for hot-working tools is a relatively new development. Their hardness also depends on the combination of carbon, tungsten, and chromium, although all of them contain 0.30–0.50% carbon. The hardest alloy, and the one which is best adapted for dies which become rather hot, carries about 6.5–7.5% of both tungsten and chromium and usually 0.20–0.60% vanadium to improve the fatigue resistance. All of them also contain 0.80–1.00% silicon to improve wear- and erosion resistance and to decrease scaling on air cooling. By decreasing the tungsten and chromium to 5.5–6.0%, steels with much better strength and shock resistance are secured. These generally are used for applications in which the operating temperatures will not exceed 700 F (370 C).

A similar steel can be secured by decreasing the tungsten to the still lower range of 0.75–1.25%, the chromium to 4.5–5.0%, and adding 1.0–1.5% molybdenum to increase the hardness to the former value. This gives not only a less expensive substitute but also some wartime strategic value as it contains less tungsten.

These are all deep-hardening steels which harden either in air or in oil. They have a medium wear resistance, good strength and shock resistance, low warpage, and high red hardness. Although they do not exhibit such good heat-resisting properties as the tungsten die steels, they are definitely stronger and can withstand considerably more shock in use. They also may be water-cooled in operation and do not show the same tendency to deep cracking as the tungsten die steels.

These tungsten-chromium die steels also tend to carburize readily and care must be taken to avoid this as their value lies partially in their low carbon contents. They can be nitrided very successfully and have been found in some cases to give two to three times as long life in the nitrided condition as in their ordinary form. Of the commercial tool steels *Pressurdie*, *Lumdie*, *K-L*, *K-M*, *K-R*, *K-S*, *Hot Form*, and *Thermold* are some of the more common examples of this group. The effect of tempering temperature on the surface hardness after oil-hardening is indicated in Fig. 512.

Their most general use is for dies, for die casting aluminum and aluminum-base alloys, and for forging dies subjected to considerable shock.

#### HIGH-SPEED STEELS

Over 85% of the high-speed steels in use before World War II were of the general type designated as 18:4:1. These contain about 0.55–0.75% carbon, 17–19% tungsten, 3.5–4.5% chromium, and 0.75–1.25% vanadium. The 18:4:2 and the 14:4:2 types are also popular, the sequence of numbers indicating the same elements.

The carbon content is important and, with constant tungsten and chromium, the hardness varies directly with the carbon content. The range 0.67–0.73% carbon seems to give the best combination of hardness, cutting ability, strength and shock resistance, and is used with the 18:4:1 composi-

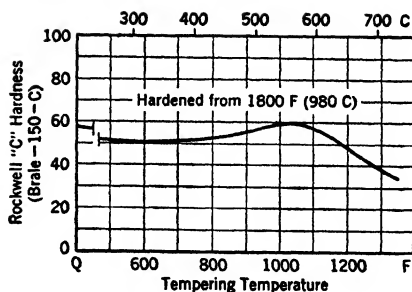


FIGURE 512. Effect of tempering temperature on the surface hardness of a tungsten-chromium die steel, containing approximately 0.60% C - 7.5% W - 7.5% Cr - 0.20% V - 0.60% Mn - 0.90% Si - rem. Fe, after oil quenching from 1800 F (980 C).

tion for tools like milling cutters, hobs, taps, broaches, drills, and reamers. A lower carbon content increases the shock resistance and makes the steel applicable for certain types of punches, such as cold nut punches, as well as for blanking dies, pipe-threading tools, and hot-working dies. A higher carbon content gives better cutting and wearing properties for many types of lathe, shaper, and planer tools, but also imparts some brittleness. Some of the better known 18:4:1 type high-speed steels are: *Special High Speed*, *Vinco*, *Star Zenith*, *Red Cut Superior*, *Clarite High Speed*, *Rex AA*, *Kutkwik*, *Blue Chip*, *Dreadnought High Speed*, *Supremus*, *Electrite No. 1*, *LXX*, *Two Star High Speed*, *Red Streak*, *B-6*, and *Wolfram*.

Fig. 513 illustrates the effect of tempering temperature on the hardness and shock resistance of a typical steel of this group.

The precise effects of *manganese* and *silicon* are not known completely but long experience has indicated that manganese should be held below 0.40% to avoid forging difficulties and to minimize breakage in heat-treatment. Silicon usually is held to the same figure although its detrimental effect is much milder than manganese and many high-speed steels have been processed successfully with silicon contents of the order of 1.0%. When present in substantial amounts it lowers the cutting life without a simultaneous drop in the hardness. For special applications, such as punches or gauges for which a smooth surface finish is desired, silicon contents of the order of 1.0–2.0% serve to eliminate the presence of tiny subsurface seams or laminations. Excessive amounts of this element may cause the alloy to graphitize, and thus, for the bulk of general-purpose requirements, silicon should be held within the stated limits.

If the *tungsten* is increased much over 18%, cutting ability and wear resistance are increased but with an accompanying increase in brittleness. Decreasing the tungsten decreases the brittleness but at the sacrifice of wear resistance. The 14% tungsten steels are of this type. It has been claimed by some that these lower tungsten steels are subject to grain growth but this is not true if proper heat-treatment is used. The tungsten content determines the optimum austenitizing temperature, and the 14% alloys should be superheated at temperatures 50° F (30° C) lower than the 18% types. Both types have the same latitude in optimum hardening range but the actual temperatures are different. Consequently, treating the 14% alloys in the higher 18% range naturally would be expected to result in grain growth but this is not the fault of the steel.

Decreasing the *chromium* under 4% decreases hardenability and cutting ability as well as the brittleness. Increasing the chromium increases the hardenability, wear resistance, and cutting ability, but also noticeably increases the brittleness.

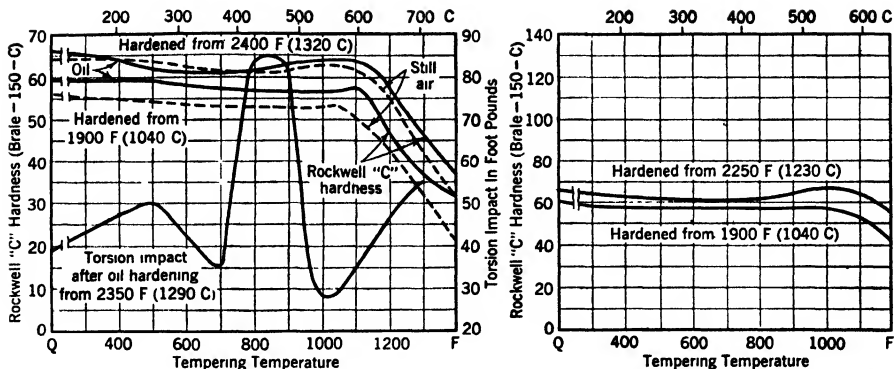


FIGURE 513. (Left) Effect of tempering temperature on some mechanical properties of an 18:4:1 high-speed steel, containing approximately 0.70% C - 15.50% W - 4.0% Cr - 1% V - 0.25% Mn - 0.25% Si - rem. Fe, after quenching in oil or in still air from 1900 F (1040 C), 2350 F (1290 C), or 2400 F (1320 C) as indicated.

FIGURE 514. (Right) Effect of tempering temperature on the surface hardness of a 5:4 type molybdenum high-speed steel, containing approximately 0.80% C - 5.5% W - 4.0% Cr - 1.65% V - 4.50% Mo - 0.25% Mn - 0.30% Si - rem. Fe, after oil quenching from 1900 F (1040 C) or 2250 F (1230 C) as indicated.

*Vanadium* materially improves the abrasion resistance and red hardness and serves to fix the safe hardening range. The addition of this element by J. A. Mathews in 1904 was probably the most notable improvement in these steels since the development work of Taylor and White. Vanadium, when first added to high-speed steels, was expensive and its increase to the present range of 1.0-1.25% was gradual. Simultaneously the carbon content was increased in the same proportion. This increase has had a beneficial effect on hardenability and has fitted the steel for use in the myriad forms of industrial multiple-point cutting tools.

The advantages of increased vanadium are secured in the 18:4:2 type for general-purpose cutting, particularly for operations in which a fine finish is desired, and the 18:4:1 steels have been displaced by it in a widely diversified field. The addition of 0.40-0.90% molybdenum also is made frequently. *H.V. High Speed, Twinvan, Vanite High Speed, Rex Supervan, H.V. Blue Chip, Supervan Dreadnought High Speed, Supremus Extra, Electrite No. 19, Super Panther, Red Tiger, ML, B-9, E.V.M., and Super Steel* are common brands of 18:4:2 high-speed steel.

If it is heat-treated properly the 14:4:2 composition compares favorably with the 18:4:1 type. The success of the 18:4:2 type probably has restricted its possible development because poor results will be secured with it, for the reasons mentioned above, if it is treated the same as 18:4:1. *Extra Special High Speed, Maxite Super High Speed, Rex Champion, Super*



*Dreadnought High Speed, Electrite Uranium, and One Star High Speed* are of the 14:4:2 type.

#### MOLYBDENUM HIGH-SPEED STEELS

*Molybdenum* is the only other “red-hardness” element that can be substituted for tungsten in substantial amounts without altering materially the general properties of high-speed steel. Since tungsten is a strategic metal, largely imported from China and Burma, it was recognized early that the development of a molybdenum high-speed steel was of considerable importance. An intensive investigation at the Watertown Arsenal about 1928<sup>6</sup> proved that satisfactory lathe tools could be processed if proper precautions were observed in the fabrication of the steel and in the heat-treatment of the tools. The principal difficulties were the tendency for the molybdenum high-speed steels to decarburize readily and for the surface oxide to volatilize.

The pioneer work of J. V. Emmons<sup>7</sup> marked the beginning of the general commercial use of molybdenum high-speed steels, particularly those having the typical composition 0.80% C – 1.50% W – 4.0% Cr – 1.0% V – 8.5% Mo – rem. Fe. These steels give satisfactory service provided they are heat-treated properly both as regards temperature and surface protection. Some of the commercial tool steels of the Emmons type are: *Carpenter Moly, Mo-Cut, Rex-T-Mo, Mogul, Tatmo, LMW, Mo-Tung, Mo-Max, HM High Speed, Vul-Mo, Mohican, S.T.M., Di-Mol, Molite 8, Star Max.*

A somewhat similar steel, with increased vanadium but without any tungsten, was developed by A. H. Kingsbury. Among the commercial alloys of this type, which have a nominal composition of 0.85% C – 4.0% Cr – 2.0% V – 8.0% Mo – rem. Fe, are: *Rex VM, MoVan No. 2, VLM, and V.M. Dreadnought High Speed.* Both of these grades have been used successfully throughout the metal-cutting industry for more than a decade. Modifications containing cobalt are made also.

A third general-purpose grade, containing less molybdenum and more tungsten, was introduced by W. R. Breeler<sup>8</sup> in 1939. A typical composition was 0.80% C – 5.5% W – 4.0% Cr – 1.5% V – 4.0% Mo and the name *5:4 type* soon was adopted for it. *Rex MM, Molite 5, D-B-L Regular, Speed Star Molybdenum, and Vulcan TM-5* are some of the names under which steels of this type are sold commercially. Even though these steels contain more tungsten than molybdenum they usually are considered as molybdenum high-speed steels. During the early days of World War II un-

<sup>6</sup> See S. B. Ritchie, *Army Ordnance*, 11, July 1930.

<sup>7</sup> J. V. Emmons, *Trans. A.S.S.T.*, 21, 1933, 193.

<sup>8</sup> See W. R. Breeler, *Trans. A.S.M.*, 27, 1939, 289–309. This also gives a good discussion of molybdenum high-speed tool steels.

forseen shortages of molybdenum made it necessary to curtail production of the high-molybdenum types and the 5:4 type became of strategic importance since it conserved both tungsten and molybdenum. It is substantially superior to the high-molybdenum types with respect to surface decarburization<sup>9</sup> but it is not quite so impervious as the 18:4:1 type unless it is heat-treated under conditions which normally would not be required for 18:4:1. Its future development is awaited with interest as increasing the tungsten content with a simultaneous slight reduction of the molybdenum may place it on a par with 18:4:1. It is entirely possible that the heat-treating procedures which were devised in times of war to use this steel properly may be adopted permanently later as routine practice. However, since approximately a third of every ton of high-speed steel melted is returned to the mill ultimately as usable scrap, it is evident that general adoption of this type of steel might lead to a critical scrap-separation problem.

Remarks similar to those made on the 5:4 type also apply in general to the other emergency steel of the war period, the so-called 6:6 type. This usually analyzes 1.15% C – 6.0% W – 4.0% Cr – 3.0% V – 5.5% Mo – rem. Fe. Because of the increased amounts of carbon and vanadium this steel is somewhat more abrasion-resistant than the 5:4 type, but it is also more susceptible to decarburization unless proper precautions are taken during heat-treatment. *Twin-Mo*, *Latrobe Double Six*, *66 High Speed*, *Star Mo*, and *6-6-2* are some of the commercial brand names of this type.

The effect of drawing temperature on the surface hardness of a steel of the 5:4 type is shown in Fig. 514. Values for the 6:6 type would be similar. It should be noticed that the hardening temperatures used are about 100–150° F (55–85° C) lower than for the 18:4:1 analyses. As mentioned previously, accurate control and adherence to this practice is necessary if excessive grain growth is to be eliminated.

#### HEAT-TREATMENT OF HIGH-SPEED STEELS

The usual heat-treatment of high-speed steels consists of a presoak at 1550–1650 F (840–900 C) followed by a rapid heat to a hardening temperature which varies with the type steel but is generally above 2000 F (1100 C). The steel is held at the hardening heat for as short a time as possible, in order to restrict grain growth, and then quenched in oil, in salt baths, or in air depending upon the particular type steel. Tempering usually is carried out, in the range 1000–1100 F (540–590 C), in two stages with a quench to room temperature in between. However, many high-speed steel tools are being quenched from the hardening heat directly into a salt bath at about

<sup>9</sup> See also J. P. Gill and R. S. Rose, *Metal Progress*, 40, 1941, 283–288; and L. C. Grimshaw and R. P. Kells, *ibid.*, 41, 1942, 76.

1100 F (590 C) and, subsequently, quenched to room temperature and given either a single or a double temper at 1000–1100 F (540–590 C). Experience has shown that the danger of cracking complex tools is much less by this method than by the conventional method.

Supposedly, the initial quench to room temperature results in an appreciable amount of retained austenite. During the first tempering treatment some of this is transformed, along with some or all the martensite present, to a very fine spheroidal structure. The cooling to room temperature following the temper transforms a large portion of any remaining austenite to martensite which, in turn, is tempered by the second reheat.

#### COLD-TREATMENT OF HIGH-SPEED STEELS

Whether or not cold-treatment of high-speed steels actually leads to increased productivity still seems to be a somewhat controversial point. Likewise, a complete understanding of the effect of the treatment seems to be somewhat obscure.

Cold treatment at about  $-100$  F ( $-75$  C) or lower, if used at all, generally is given to high-speed steel parts between the two tempering treatments. It seems hardly likely that much austenite still could be retained at this point and hence the function of the treatment is not entirely clear unless it is connected with strain relief in some manner. Regardless of this, many examples of improved life by this method have been reported and, although not everyone seems to have had equal success, the process would appear to merit trial particularly since better combinations of strength, hardness, and ductility reportedly have been secured by this method than by any other.

#### METALLOGRAPHIC STRUCTURES OF HIGH-SPEED STEELS

The metallographic structures of all high-speed steels in the “as-cast” condition show considerable segregation, as illustrated in Fig. 515*a*, although higher carbons tend to accentuate this difficulty. Their properties are dependent to a large extent on the effect of the added elements and heat-treatments in breaking up the segregate to give a matrix of the more homogenous type shown in the quenched structure in Fig. 515*b*. The steels are air- or oil-hardening and have a high wear resistance combined with deep-hardening characteristics, low shock resistance, low warpage, and a high red hardness. These characteristics make them useful for cutting tools of all types, and especially those intended for severe hot-work such as blanking dies and similar dies for hot-work.

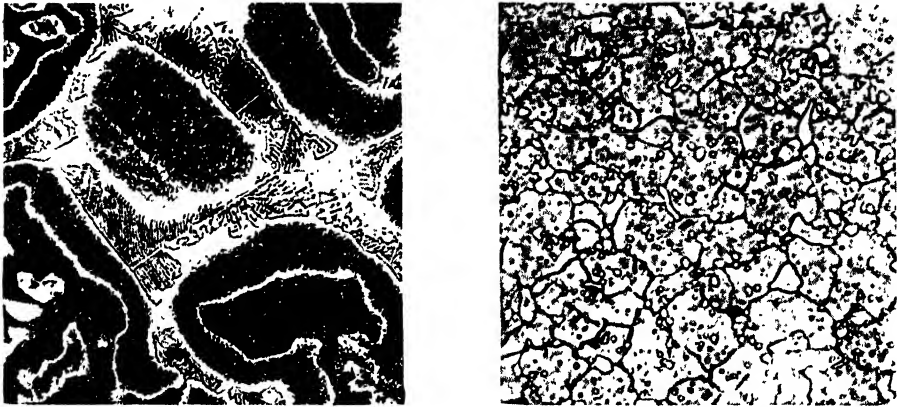


FIGURE 515. Metallographic structures of an 18:4:1 type high-speed steel. Etched with nital.

a. (Left) As cast, showing eutectic segregate high in tungsten and carbon.  $\times 300$ . (Photomicrograph by C. L. McVicker.)

b. (Right) After quenching, showing free complex-carbides in a martensitic background.  $\times 500$ . (Photomicrograph by R. P. Stemmler.)

#### COBALT HIGH-SPEED STEELS

Cobalt sometimes is added to the 18:4:1, 18:4:2, 14:4:2 and the various molybdenum high-speed steel base analyses, the cutting properties increasing up to about 12% cobalt. Generally in these alloys the carbon also must be increased somewhat to retain the hardenability, 0.65–0.80% carbon being a common range. Molybdenum in amounts of 0.50–1.0% also may be added to increase the cutting ability, corresponding to an increase of twice that amount of tungsten. These steels are more brittle than the same steels without cobalt; they harden with a finer grain and are much more subject to cracking in larger sections. They also are susceptible to a soft skin, resulting from decarburization during hardening. This makes the use of controlled atmosphere furnaces advisable. However, they usually are less susceptible to grain growth than the cobalt-free alloys and thus can be hardened from a higher temperature. The cobalt steels are adapted particularly to cutting hard, gritty, or scaly materials, such as cast irons, heat-treated steels, or sand castings, and are not so good for soft materials as for hard. Because of their soft skin, they should be used primarily for tools that will be ground after hardening. Some of the commoner brands include: *Maxite Super High Speed*, *Comokut High Speed*, *Cobalt*, *Co Co Turning*, *Rex AAA*, *King Cobalt*, *Jessop Purple Label*, *Electrite Cobalt*, *Super Cobalt*, *Ultra Cobalt*, *Three and Five Star High Speed*, *B-7*, *Red Cut Cobalt*, *Bonded Car-*

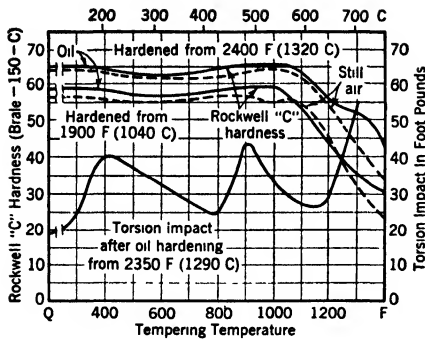


FIGURE 516. Effect of tempering temperature on some mechanical properties of a cobalt-type high-speed steel, containing approximately 0.75% C - 18.80% W - 4.50% Cr - 1.50% V - 5.20% Co - 0.60% Mo - 0.35% Mn - 0.35% Si - rem. Fe, after quenching in oil or in still air from 1900 F (1040 C), 2350 F (1290 C), or 2400 F (1320 C) as indicated.

type, of the elements manganese, silicon, molybdenum, tungsten, aluminum, nickel, and chromium. The specific composition determines the heat-treatment that must be used, some types hardening in air and some in oil or water. As a general rule, these steels are used more for shock- and wear-resistant tools than for cutting tools. Their characteristics correspond to the classifications of tool steels which already have been discussed.

All of these alloys can be hot-forged in the range 1750–1950 F (950–1050 C); and they can be annealed, for reworking after hardening, by heating to 1350 F (730 C) and slow cooling. Normalizing, by air-cooling from 1600–1700 F (870–930 C), gives the customary structures and properties, the best temperature depending upon the particular alloy. However, if the correct heat-treatment is given, depending on the particular composition, the cementite partially decomposes to ferrite and graphite giving an alloy which may contain from 0.30–0.70% graphite and which will have a Brinell hardness of 190–240. This heat-treatment consists essentially of heating thoroughly at 1380–1450 F (750–790 C) followed by slow cooling at a rate of 10–40° F per hour, to a temperature in the range 900–1250 F (480–680 C) depending upon the particular alloy.

In the graphitic condition the machinability is excellent and tools can be made readily. Subsequent hardening then can be carried out just as in the regular tool steels of similar type, since heating above the critical range causes both the graphite and the cementite to redissolve as austenite in so

vide, *D-6-Co*, *Circle C*, *Rex 95*, *Halcomb*, *999 High Speed*, and *B-8*. Fig. 516 illustrates their variation of hardness and shock resistance with tempering temperature.

### GRAPHITIC STEELS

Certain tool steels manufactured by the Timken Roller Bearing Company can be so heat-treated that their metallographic structure contains a considerable amount of free graphite, a constituent which increases machinability appreciably. These steels, known as *Graph-Sil*, *Graph-Mo*, *Graph-Tung*, *Graph-Al*, and *Graph-M.N.S.*, contain 1.5% carbon and varying amounts, depending on the

far as this is possible. Any undissolved graphite remaining after hardening tends to improve the nonseizing characteristics of the alloy without interfering in any way with its hardness.

### *Alloys, Other Than Steels, Used for Tools*

#### SINTERED CARBIDES

Tools for the most severe usage are made from compressed mixtures of diamonds or various metal carbides, sintered in nonoxidizing atmospheres with some binding material having a lower melting point. If the tool first is sintered partially, a certain amount of forming and shaping can be done before the final sinter at a higher temperature to obtain the maximum hardness. The range 2550–2900 F (1400–1600 C) is customary for the final treatment. The powders in general use are carbides of tungsten, tantalum, and titanium, either alone or in combination depending upon the application. Cobalt is the most common binding agent although tungsten powder and various combinations of metals also have been used, sometimes with good results.

The predominant material at the present time is a tungsten carbide with cobalt binder (3–13% cobalt).<sup>10</sup> The others are relatively recent developments which have indicated some exceptional characteristics. During the sintering operation appreciable shrinkage, sometimes as much as 10%, may occur. This is affected by both the pressure and the sintering temperature. Although the tungsten carbide mixtures are not suited particularly well to cutting steel, because of the tendency of the chips to weld to the tool, they can be improved by the addition of some of the other carbides, especially the titanium carbide. Some of the common commercial names for these sintered carbide alloys are *Vascoloy-Ramet*, *Firthaloy*, *Firhite*, *Carmet*, *Carboloy*, *Widia*, and *Kennametal*. Some types of these contain titanium carbide, tantalum carbide, and columbium carbide in addition to tungsten carbide.

The mechanical and physical properties of the tool depend on the composition and the proportions of the mix used, as well as the conditions of sintering. The modulus of elasticity of the sintered material may run as high as 69,000,000 psi, considerably higher than that of any other known material, and the hardness measured on the Vickers Brinell scale frequently will run between 1300 and 1400. Compressive strengths are apt to be higher than 700,000 psi, with thermal conductivities about 50% greater than those of tool steel.

<sup>10</sup> See W. P. Sykes, *Trans. A.I.M.E.*, **128**, 1938, 76–86.

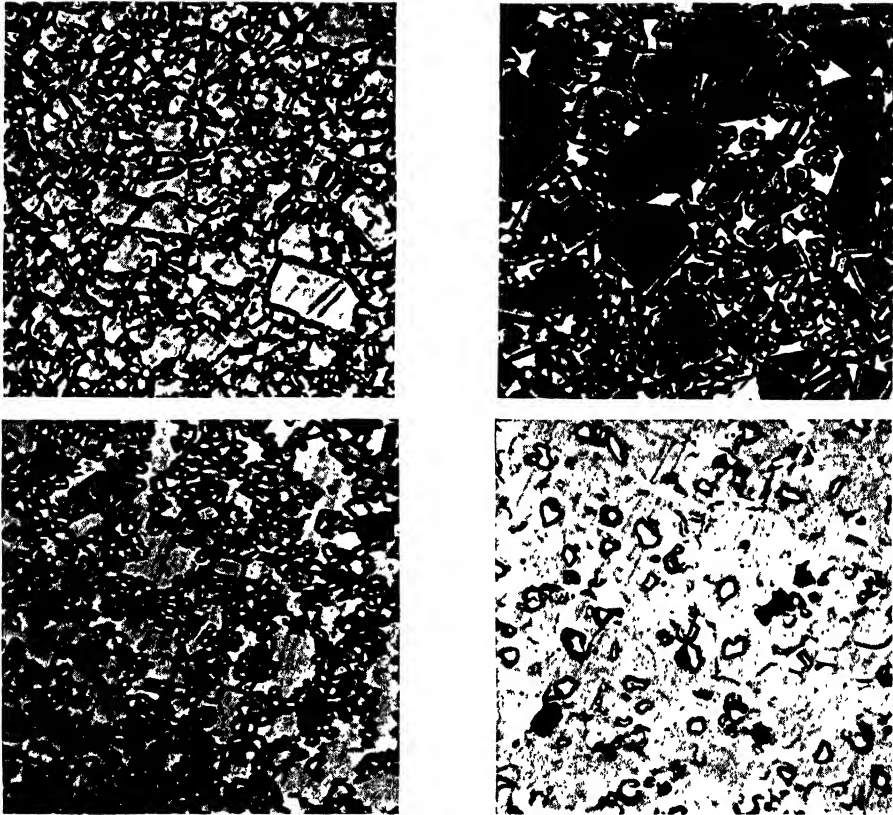


FIGURE 517. Metallographic structures typical of sintered carbide tool materials.  $\times 1500$ .

a. (Upper left) 97% WC - 3% Co (transverse strength 137,000 lb, density 15.05).

b. (Upper right) 87% WC - 13% Co (transverse strength 318,000 lb, density 14.20).

c. (Lower left) 60% WC - 27% TaC - 13% Co, sintered at 2640 F (1450 C).

d. (Lower right) 61% WC - 32% TiC - 7% Co, sintered 2640 F (1450 C).

(From *Cemented Tungsten Carbide Alloys* by W. P. Sykes, *Trans. A.I.M.E.*, 128, 1938, 76; photomicrographs courtesy Dr. Sykes.)

The carbides of tantalum and titanium generally are used in mixtures with tungsten carbides. The tantalum carbides seem to have a greater resistance to certain types of corrosion and a lower coefficient of friction than tungsten carbide with respect to steel.<sup>11</sup> The addition of titanium carbide seems to impart remarkable properties and to increase appreciably the ability to cut steel.

Metallographic structures typical of the sintered carbide tools are shown in Fig. 517. In *a*, *b*, and *c* the crystals are probably tungsten carbide (WC) and the lighter background is either cobalt or, more probably, an eutectic

<sup>11</sup> See also P. M. McKenna, *Trans. A.I.M.E.*, 128, 1938, 90-101.

alloy of cobalt and the carbides. The white particles in *c* are probably tantalum carbide. In *d* the crystals are probably residual tungsten carbide and the background is a reaction product between the two carbides and cobalt, possibly a quasi-binary or ternary eutectic.

Cemented carbide tools also find extensive use in drawing dies for bars, rods, wire and tubing as well as for dies for extrusion, deep drawing and forming, both cold and hot. They are used for these purposes in the working of such materials as high- and low-carbon steels, alloy- and stainless steels, tungsten, molybdenum, nickel and nickel alloys, aluminum alloys, copper, brass, zinc, and precious metals. They also are used for cutting tools for machining cast iron, aluminum, brass, bronze, copper, babbitt, zinc, and for many nonmetallic materials. The proper use of cemented carbide tools frequently leads to average increases in production of about 60% with cast iron, 35% with steel, and sometimes as high as 500%, or as low as 15%, with nonferrous materials. Savings in production costs may run from 10 to 75%, averaging around 25%.

These tools are fairly brittle and this must be considered in their use. Generally, speeds about twice as fast as those suitable for high-speed tools, with feeds about a third less, are used to start, and conditions varied from there until satisfactory results are secured. However, if optimum results and greatest efficiency are desired, no tungsten carbide tool should be employed unless the job first is studied by a qualified tool engineer. For example, cutting applications involving intermittent loading generally are avoided with these sintered carbide tools as their impact strength is not great. However, experience has shown that, with proper tooling, even many intermittent cutting operations can be carried out successfully.

Cemented carbide tools generally are made up for use as a tip or insert and brazed or silver soldered into place on shanks which frequently are made of silicon-manganese steels of the chisel type, although other types are used. High-strength cast-iron shanks also are becoming very popular because they have about the same coefficient of expansion as the carbides. This sets up less stress in cooling the assembly after brazing and therefore assures a good strong bond. After the tip is fastened to the shank, grinding to shape must be done with diamond dust or other special abrasives because of the general characteristics of the cemented carbide alloys.

#### CAST COBALT-CHROMIUM-TUNGSTEN ALLOYS

The alloys of the types sold commercially under the names *Stellite* and *Rexalloy*, among others, were discovered by Elwood Haynes while searching for durable spark-plug electrodes. They contain ordinarily about 1.25%



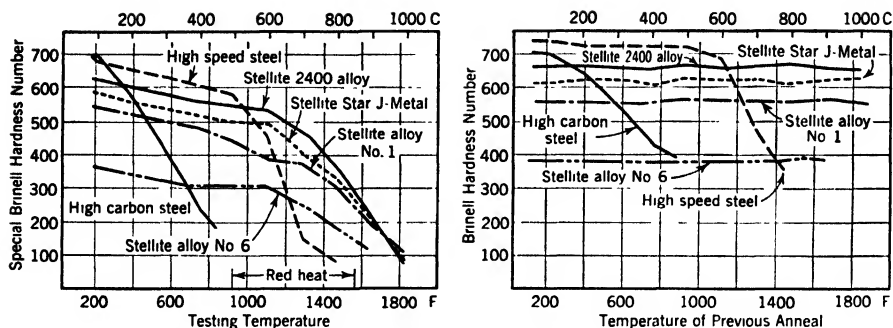


FIGURE 518a. (Left) Hardness, at elevated temperatures, of Stellite alloys used for cutting tools and for wear resistance. Sample was surrounded by furnace, heated 30 min at temperature, trap opened, and Brinell indentation quickly made with a carbide ball.

b. (Right) Hardness of alloys at room temperature after 30 min at heat and slow cooling. (Courtesy Haynes Stellite Company.)

carbon, 65% cobalt, 28% chromium, and 4% tungsten with sometimes small additions of other elements.<sup>12</sup> Three outstanding properties in addition to wear resistance make them desirable for cutting tools:

1. Their hardness and strength when hot are reduced to a much less extent than is true of other alloys of equivalent hardness. This is shown in Fig. 518a.
2. They are highly resistant to corrosion and oxidation.
3. They have a low coefficient of friction with respect to steel and many other materials.

Heat-treatment has little effect on the strength, hardness, or ductility of the commercial grades, as illustrated in Fig. 518b, and varying the composition is the method of controlling these characteristics used most frequently. In the cast varieties the strengths of these materials may vary between 45,000 and 80,000 psi, and the forging or rolling types may range as high as 130,000 psi. The softer alloys are stronger and more ductile. At 1800 F (980 C) the strengths are of the order of 20,000 psi for both types. Hardnesses will vary between 400 and 600 Brinell. The alloys are expensive and generally are used as inserts or as thin facing layers welded onto the cutting edge by standard welding processes. This is known as *stelliteing*.

These alloys are used to protect the cutting edges and wearing surfaces of hot shears, trimming dies, agricultural instruments, cams, gauges, punches, valve seats for high-pressure steam lines, and exhaust-valve seats in internal combustion engines, cf. Fig. 427. They also have a very high reflecting power and where this, in combination with scratch hardness and tarnish resistance, is desired they often are used. Mirrors made of them re-

<sup>12</sup> This field has been well reviewed by W. A. Wissler, *Metal Progress*, 36, 1939, 131.

tain their reflecting power up to about 500 F (260 C). Their chief disadvantages are their low strength, compared to steel of equal hardness, and their high cost.

By adding 4–5% molybdenum to the alloys the cobalt content can be made as low as 20% without decreasing the hot hardness markedly. A recent development, which enhances performance materially, has been the addition of about 0.20% boron.

Most stellite cutting tools are now made of *Star J-Metal* (45–55% cobalt, 30–35% chromium, 12–17% tungsten) or the *98M2* or *2400* grades, both fairly recently developed compositions; hard-facing rod from *Haynes Stellite No. 1* (43%<sup>13</sup> cobalt, 34%<sup>14</sup> chromium, 14%<sup>14</sup> tungsten), *No. 12* (47%<sup>13</sup> cobalt, 34%<sup>14</sup> chromium, 10%<sup>14</sup> tungsten), or *No. 6* (55%<sup>14</sup> cobalt, 33%<sup>13</sup> chromium, 6%<sup>14</sup> tungsten); and forged products from *Stellite No. 6*. The metallographic structures of some of these are shown in Fig. 519. They are essentially, composed of two solid solution phases, one chromium-rich, and containing both tungsten and carbon, and the other cobalt-rich but also containing carbon. Most of the alloys have secondary constituents with a structure like an eutectic. The dendritic primary structure typical of all such complex alloys in the cast condition can be seen readily.

#### CAST-IRON METAL-WORKING DIES

In the automotive and other industries in which metal must be formed, bent, drawn, or forged either hot or cold, alloy cast irons have been used very successfully for dies, especially for working sheet metal.<sup>15</sup> In general these are gray irons containing 2.5–3.0% carbon, 1.25–2.5% silicon, 0.60–0.90% manganese, 1.0–2.0% nickel, 0.50–1.0% molybdenum, and 0.1–0.5% chromium. Metal sections are usually greater than 2 in. and less than 15 in., and die weights may run as high as 30,000 lb. These analyses can be heat-treated to increase wear resistance, strength, and shock resistance. They are appreciably lower in cost than die steels and in addition have the advantage of being cast to approximately the final shape thereby decreasing the machining costs appreciably.

#### ZINC-ALLOY STAMPING DIES

In the aircraft industry in particular the number of metal stampings made on a set of tools from aluminum or magnesium sheet has seldom been large enough to justify the use of conventional forms of presses or of steel

<sup>13</sup> Min

<sup>14</sup> Max

<sup>15</sup> See, for example, A. B. Everest, *Sheet Metal Industries*, 8, 1934, 281–283.

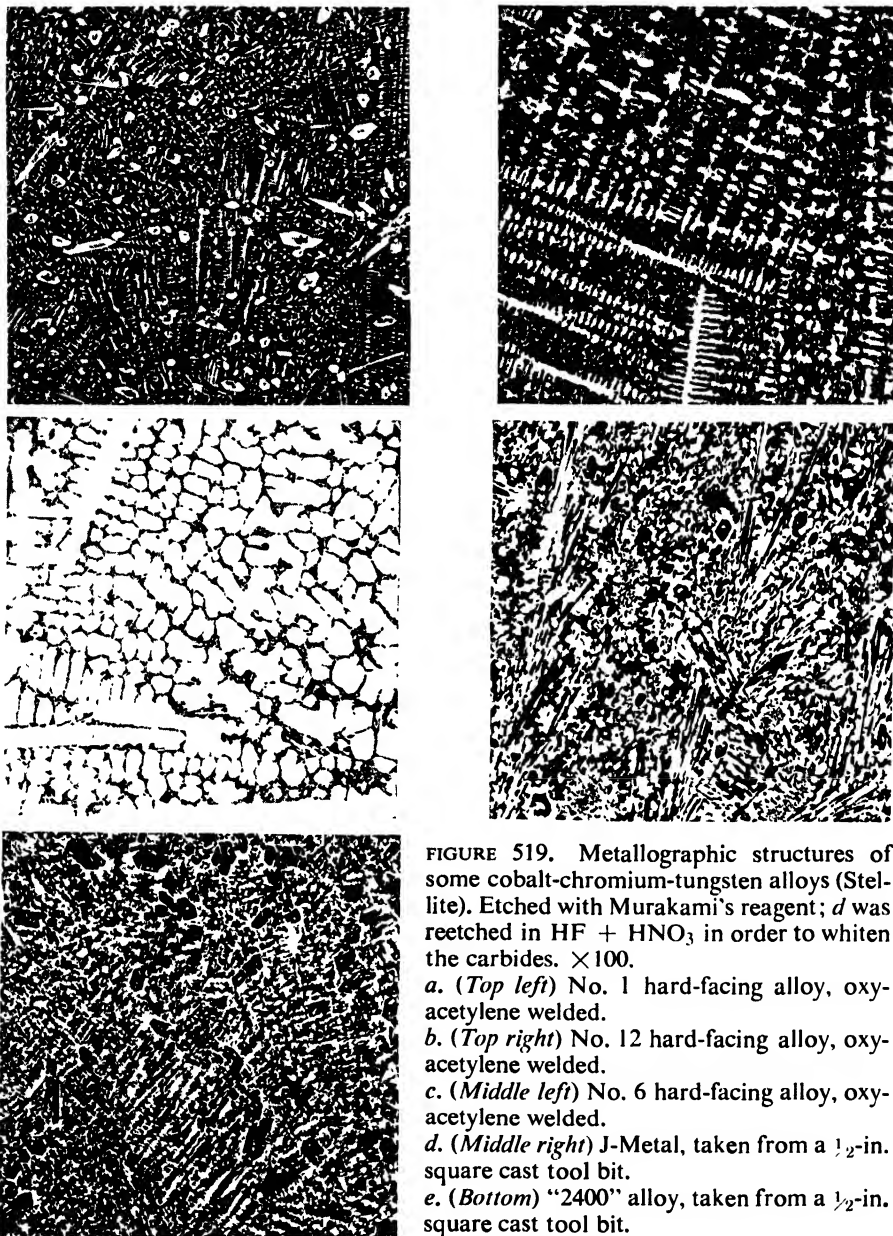


FIGURE 519. Metallographic structures of some cobalt-chromium-tungsten alloys (Stellite). Etched with Murakami's reagent; *d* was reetched in  $\text{HF} + \text{HNO}_3$  in order to whiten the carbides.  $\times 100$ .

*a.* (Top left) No. 1 hard-facing alloy, oxy-acetylene welded.

*b.* (Top right) No. 12 hard-facing alloy, oxy-acetylene welded.

*c.* (Middle left) No. 6 hard-facing alloy, oxy-acetylene welded.

*d.* (Middle right) J-Metal, taken from a  $\frac{1}{2}$ -in. square cast tool bit.

*e.* (Bottom) "2400" alloy, taken from a  $\frac{1}{2}$ -in. square cast tool bit.

(Photomicrographs courtesy W. A. Wissler, Union Carbide and Carbon Research Laboratories, Inc.)

or cast-iron dies. To take care of this intermediate range between mass production and hand tooling, in which the tooling required with ferrous materials is too expensive unless large quantities can be run, a zinc alloy, sold

under the names *KirkSITE* and *Zamac*, has been developed, especially for use in the critical parts of the die and for dies subject to wear or extreme pressures. These dies usually are used in conjunction with a rubber punch<sup>16</sup> in hydraulic presses according to what is known as the Guerin process. However, because of the low melting point of the alloy, 715 F (380 C), punches of lead alloys can be cast directly from the zinc die if they must be used instead. For some operations the punch also is made from the zinc alloy.

Essentially these are alloys of zinc with about 4% aluminum and are very comparable in many respects to some of the zinc-base die-casting alloys which have been discussed in Chap. XIII. In sand castings, tensile strengths of 35,000–38,000 psi can be developed, with Charpy impact strengths ( $\frac{1}{4}$  in.  $\times$   $\frac{1}{4}$  in. specimen and 40 mm span) of 2–4, compressive strengths of 60,000–75,000 psi, elongations of 3% in 2 in. and hardnesses of 80–107 Brinell.

#### NONSPARKING TOOLS

As discussed in Chap. XVI, the precipitation-hardening alloys of copper with about 2% beryllium can be heat-treated to strengths as high as 175,000–200,000 psi and hardnesses of 350 Brinell, without losing all their ductility. Because of the predominance of copper in them, they will have non-sparking characteristics which make them suitable for hand tools in applications where sparking would be serious, such as around explosives, gas plants, or petroleum refineries. Although they are much better for this purpose than steel tools of similar types, they are fairly expensive, and since tools are not the only possible sources of sparking, they find a somewhat limited application.

The aluminum bronzes also have found some usage for nonsparking tools largely because of their wear resistance and great hardness. Tools made of these alloys have a reasonable life which is, however, somewhat inferior to that of the best steel tools.

#### FUTURE TRENDS IN TOOLS

There is a possibility that almost carbon-free alloys of iron with cobalt and tungsten or molybdenum may be developed into excellent tool materials.<sup>17</sup> These alloys can be heat-treated to high hardnesses because of

<sup>16</sup> This process is discussed briefly by H. Chase, *Metals and Alloys*, 12, 1940, 436–441.

<sup>17</sup> See, for example, W. P. Sykes, *Trans. A.S.M.*, 25, 1937, 953–1012; *ibid.*, 30, 1942, 147–164.

their precipitation-hardening characteristics. Intermetallic compounds of iron-tungsten-cobalt, or iron-molybdenum-cobalt precipitate from solid solution after aging at about 1150–1350 F (620–730 C) for several hours. Once secured, these hardnesses will persist for long periods, even at temperatures as high as 1200 F (650 C).

#### SELECTION OF TOOL MATERIALS

For very many applications a plain carbon tool steel, containing, possibly, small amounts of vanadium or chromium, will be found to be entirely suitable for tool purposes. Steels of this type are comparatively inexpensive, and are both machined easily and hardened easily. Consequently, it seldom is advisable or necessary to use a more highly alloyed steel if it can be avoided. The plain carbon steels, when they are found to be unsuitable, usually lack one of the following basic requirements:

1. *Wear resistance*.
2. *Shock resistance and strength*, such as are required for tools like shear blades, chisels, and boiler punches.
3. *Hardening accuracy and safety, or nondeforming characteristics*, as are required both for tools that cannot be ground after hardening and, therefore, must hold their shapes accurately, and for tools that are so intricate that they might crack when quenched in water.
4. *Red hardness*, as would be required for high-speed cutting tools and tools for hot-forging, hot-extruding, and hot-molding.

When these properties are lacking in the plain carbon steel, steels of one of the other types must be used. In general, steels of greater wear resistance will be found in the other members of the first group; steels of greater shock resistance and strength and of lower warpage will be found in the second group of the classification used; and steels of greater red hardness will be found in the third group.

It cannot be emphasized too strongly that all tool problems are, to a large extent, dependent upon experience. Although the plain carbon steels are entirely suitable for starting points, if not for the final choice, the toolmaker must find out by experience what properties a given tool lacks and then select a new composition or treatment to make up for these missing properties, if it is possible to find one. For this reason, it frequently is found to be desirable to standardize on tool steels of one manufacturer, if this is at all possible, because each manufacturer generally maintains a technical staff and endeavors, to some extent at least, to correlate his series of tool steels so that a fairly definite relationship between the properties of the various types is known. Under these conditions, if a given composition is de-

ficient in some characteristic, the best steel for supplying the deficiency is usually much easier to find than if it is necessary to proceed blindly. Where this procedure is not followed, a cut-and-try method, which entails a great deal more work and is unlikely to result in as efficient a use of cutting materials, must be used not only because of the impossibility of evaluating all of the intangibles found in the steels of various manufacturers, but also because of the usual desire of the user merely to find a steel good enough to fill the need rather than to secure the best steel for that purpose.

*For Further Study Refer to*

1. *Metals Handbook*: American Society for Metals, Cleveland, Ohio, 1939 (usually published triennially). A new edition will appear in 1948.
2. *Tool Steels*, by J. P. Gill, R. S. Rose, G. A. Roberts, H. G. Johnstin and R. B. George: American Society for Metals, Cleveland, Ohio, 1944.
3. *Tool Steel Simplified*, by F. R. Palmer: The Carpenter Steel Co., Reading, Pa., 1937.
4. *High Speed Steel*, by M. A. Grossman and E. C. Bain: John Wiley & Sons, Inc., New York, 1931.
5. *Steel and Its Heat Treatment*, 4th ed., by D. K. Bullens: John Wiley & Sons, Inc., New York, 1938.
6. *The Alloying Elements in Steel*, by E. C. Bain: American Society for Metals, Cleveland, Ohio, 1939.
7. *The Making, Shaping, and Treating of Steel*, 5th ed., by J. M. Camp and C. B. Francis: Carnegie-Illinois Steel Corp., Pittsburgh, Pa., 1940.
8. *The Metallography and Heat Treatment of Iron and Steel*, 4th ed., by A. Sauveur: University Press, Cambridge, Mass., 1935.
9. *Transactions American Society for Metals*: A.S.M., Cleveland, Ohio (published annually).
10. *Transactions American Institute of Mining and Metallurgical Engineers*: A.I.M.E., New York (published annually).
11. *Metal Progress*: American Society for Metals, Cleveland, Ohio (published monthly).
12. *Materials and Methods* (formerly *Metals and Alloys*): Reinhold Publishing Corporation, New York (published monthly).
13. Publications of:  
Allegheny-Ludlum Steel Corp., Brackenridge, Pa.  
Ampco Metal, Inc., Milwaukee, Wis.  
Anaconda Copper Co., New York, N. Y.

Beryllium Corp. of America, Reading, Pa.  
Bethlehem Steel Co., Bethlehem, Pa.  
Braeburn Alloy Steel Co., Braeburn, Pa.  
Carboloy Co., Inc., Detroit, Mich.  
Carpenter Steel Co., Reading, Pa.  
Columbia Tool Steel Co., Chicago Heights, Ill.  
Crucible Steel Co. of America, New York, N. Y.  
Firth-Sterling Steel Co., McKeesport, Pa.  
Haynes Stellite Co., Kokomo, Ind.  
Jessop Steel Co., Washington, Pa.  
Latrobe Electric Steel Co., Latrobe, Pa.  
The Midvale Co., Philadelphia, Pa.  
Universal-Cyclops Steel Corp., Bridgeville, Pa.  
Vanadium Alloys Steel Co., Latrobe, Pa.  
Vulcan Crucible Steel Co., Aliquippa, Pa.

## FUNCTION OF A BEARING METAL

THE PRINCIPAL FUNCTION OF A BEARING METAL IS TO PROVIDE a rolling or a sliding contact with another surface, usually of steel, with a minimum amount of friction. However, despite the fact that modern bearings date back about 100 years to the original patents of Isaac Babbitt (1839) on the soft tin-base alloy which now bears his name, and despite the fact that metallic bearings in some form have been used for more than 2000 years, very little actually is known about the specific requirements of a bearing metal. Each application has its own problems which can be solved only by consideration of all the factors involved. Even then, considerable experience under actual operating conditions usually is required to ensure that unexpected variables will not arise. Modern high-speed engines, requiring heavy-duty bearings, have introduced many problems that were not present before.

## GENERAL REQUIREMENTS OF A BEARING METAL

Fundamentally, a bearing is a surface which must support a load at a temperature which is dependent upon its method of operation. Furthermore, since it is almost impossible, practically, to obtain perfect alignment in moving parts, the bearing must have sufficient plasticity to adjust its shape to compensate for any deviations. As a rule, the bearing will be completely separated from the shaft by an oil film, and it must be, therefore, of such a nature that the film can form readily and remain continuous. However, the bearing also should have inherent properties to enable it to run dry for limited periods when lubrication may be inadequate or restricted. Since the oil film is so important, the bearing must resist any corroding effects of the oil although the present practice of adding inhibitors to oils tends to minimize this difficulty. Furthermore, the oil, especially after use, frequently will contain an accumulation of hard particles and grit. Under such conditions the bearing should be able to embed these particles in a relatively soft matrix, where they will be harmless, rather than let them be ground between the bearing and the shaft, scoring both.



## CHARACTERISTICS OF BEARING METALS

Because of the great variety of applications for bearings, each of which will have its own peculiar requirements, it is extremely difficult to specify characteristics or requirements which are applicable to all of them. In general, it may be said that the following characteristics are desirable, but other than the last three, their relative importance depends almost entirely on the type of application and the operating conditions which must be met.

1. Compressive strength
2. Resistance to wear and scoring
3. Plasticity and conformability
4. Toughness and shock resistance
5. Embedability
6. Thermal conductivity
7. Chemical stability and resistance to corrosion
8. Low coefficient of friction with respect to the shaft material
9. Bearing fatigue resistance
10. "Oiliness," or the ability to produce and maintain a continuous oil film on its surface
11. Freedom from brittleness and spalling
12. Low cost

In general, these characteristics must be retained not only at atmospheric temperatures, but also to as great an extent as possible at the operating temperatures, which are usually somewhat higher. Probably no other class of service requires a greater use of the fundamental characteristics of metals.

## CLASSIFICATION OF BEARING APPLICATIONS

In classifying bearing applications, three main factors must be considered:

1. Load Type: reciprocating or steady
2. Load Magnitude: heavy, medium or light
3. Operating Speed: high, medium or low

It is these which largely control the selection of a suitable bearing alloy.

The majority of bearings, and particularly journal bearings, are subjected to reciprocating loads and hence are more likely to fail by fatigue than any other cause, provided they are run long enough and the load exceeds the endurance limit. Under such conditions, the speed and time of operation must influence the maximum permissible loading. For example, although a maximum unit pressure of 1500 psi might be quite safe for con-

ventional steel-backed tin-base babbitt bearings in a pleasure car, the same type of bearing in a rail car engine, which is expected to operate 24 hr per day for 2–3 yr, should not be expected to bear more than 800–1000 psi.

On the other hand, loading of electric-motor bearings is comparatively steady, assuming proper alignment, of course, and light, so fatigue is seldom an important factor in failure. However, the high speed at which these bearings customarily operate make the other characteristics more important.

Applications in which the load is heavy and the speed low, as in transmissions, axles, piston pins, etc., generally are filled by *bushings* of the self- or partially lubricated type. Materials for such applications are discussed in Chap. XVI. These are usually copper-tin or copper-tin-lead alloys having considerable mechanical strength, but when the load is light and the speed low, an ordinary 90:10 brass (commercial bronze) bushing may be entirely adequate.

#### CLASSIFICATION OF BEARING METALS

The commercially important bearing metals<sup>1</sup> are largely of the *white metal* group, which includes the alloys of tin, lead, zinc, aluminum, or cadmium base. The *bearing bronzes*, which include all the alloys of copper used for this purpose, are important for both heavy- and light-duty bearings, for bushings, and for certain oilless bearings, most of which are made by powder metallurgical methods. Recently, certain silver and silver alloy bearings, such as S.A.E. No. 17, also have become important, especially for aircraft applications.

In the friction bearings it generally is found that, in so far as actual operating results are concerned, the exact chemical analysis of a group of bearings is of much less importance than the manner in which they are made, always provided, of course, that reasonable limits are maintained and that impurities are controlled properly.

#### TESTING OF BEARINGS

Although bearing specifications usually cover chemical composition, tensile strength, elongation, and hardness, these characteristics serve more as a check on uniformity and adherence to required standards than as a real test of bearing efficiency or of probable life. As a result, bearing service or life has been determined largely by trial in actual service or in test in-

<sup>1</sup> See H. W. Gillett, H. W. Russell, and R. W. Dayton, *Metals and Alloys*, **12**, 1940, 274–283, 455–463, 629–638, 749–758, 768, for an excellent review of this subject.

stallations. Many attempts have been made and are being made to test bearings in various wear and seizure tests,<sup>2</sup> but no wholly satisfactory accelerated test is available. Some testing machines, which closely imitate service conditions, give fairly quantitative results.

Pounding tests<sup>3</sup> are of some value as they definitely differentiate certain types of alloys with reference to their ability to take abuse. Here again, however, manufacturers and users do not always agree entirely as to the relative importance of pounding, bearing pressure, sliding friction, and lubricants in causing failure, so the type of application must continue to be the real determining factor in setting up acceptance tests.

#### STRUCTURE OF BEARING METALS

There is a considerable difference of opinion regarding optimum requirements for the structure of bearing metals. For a long time, because of the experience with babbitt metals, it was thought that the most desirable structure was a relatively soft matrix in which were embedded hard particles which would carry the load. For some classes of service there is no doubt that this is true, but for other classes nothing could be farther from the structures that have given best results. The characteristics that cause two metals to "run together" or to form readily a continuous oil film between them are as yet poorly understood.

#### BACKING FOR BEARINGS

Most bearing metals have too little strength of their own to be able to carry the required loads unaided. Consequently they generally are used in connection with a backing material which may be either steel or a copper-tin bronze, usually containing varying amounts of lead, although, in modern automotive and Diesel practice, the bronze backing is usually only an intermediate layer between the steel and the white metal surface.

The bond between the bearing and the backing is particularly important. Generally the alloy bonds are of one of two types. Most of them depend on effects similar to those found in galvanized coatings on steel, the bearing metal forming intermetallic compounds with the backing metals thus producing a comparatively brittle bond. However, there are also cases in which one of the elements in the bearing appears first to dissolve in the backing and the bonding alloy then is formed with this dissolved element,

<sup>2</sup> See, for example, E. A. Ryder, *Metals and Alloys*, 11, 1940, 69-74; A. F. Underwood, *A.S.T.M. Symposium on Lubricants*, 1937, 29-52; J. R. Connelly, *Trans. A.S.M.E.*, 57, 1935, 1S-35-39.

<sup>3</sup> See H. Greenwood, *Journ. Inst. Met.*, London, 55, 1934, 77-87; O. E. Harder and C. S. Cole, *Trans. Amer. Found. Assoc.*, 41, 1933, 314-329.

giving a bond which is more ductile than the compound type and appears to be stronger in most tests. In general, the copper-lead alloys give the strongest bond with a steel backing, followed by the cadmium-base and the tin- and lead-base alloys.

The bronze bearing shells tend to give a better bond than the steel. They machine better, as a rule, than steel; and in case of failure of the bearing, the lining itself has some bearing characteristics and would thus tend to keep damage to the shaft to a minimum. However, bronze backings are also more expensive than steel, and hence are used much less frequently than it except in some types of railroad service for which they are standard.

#### THICKNESS OF BEARING LININGS

The fact that the bearing capacity of white metal layers is increased as the thickness of the lining is decreased has brought about some very radical changes in bearing design and use in the automotive field during the past few years,<sup>4</sup> and has been more effective in increasing bearing life than any of the changes in composition that have been tried. The conventional babbitt-on-steel bearing has a white metal thickness of 0.010–0.0625 in. and should not have to bear a maximum unit pressure of more than 1200 psi if a reasonable life is desired. As the lining thickness decreases below 0.010 in. the life of the bearing increases very rapidly. Linings of the order of 0.0015 in. thick are coming into use because of this although the commercial *microbearing*, with a range of 0.002–0.005 in. and carrying a mean unit pressure of no more than 1800 psi, is most common.

The combination of this decreased lining thickness with a tendency to reduce automotive operating temperatures also has resulted in an increased use of certain lead-base alloys in place of tin-base babbitts for the bearing layer, until today the largest number of automotive bearings are normally of this type. When babbitt linings were of the order of  $\frac{1}{8}$  in. thick, lead-base babbitt was not so satisfactory as tin-base, but, with thin linings and the proper alloy, it is in most cases entirely suitable especially when the bearing is designed properly for it.

With such thin layers there is always some possibility that, because of warpage of the steel backing during coating by fusion methods or of misalignment in installation, the lining may be too thin in places to give adequate properties. Exposure of bare steel because of wear or corrosion would tend to result in seizure against the shaft. To overcome this the *triplex*, *tri-metal*, or *sandwich bearings* were developed. In these a thin layer of a material of intermediate properties is interposed between the steel backing and

<sup>4</sup> See, for example, A. F. Underwood, *S.A.E. Journal*, 43, 1938, 385–392.

the white metal bearing surface. Such intermediate layers as cast leaded tin-bronze, copper-lead alloys applied by casting, by copper brazing methods or by powder metallurgy, or a 60% Cu-40% Ni powder metallurgy alloy which is sintered on to a steel strip to form a porous matrix which the lead-base babbitt penetrates producing a strong mechanical bond,<sup>5</sup> are typical of some that have been used successfully. This process is apt to be complicated somewhat by the difficulty of securing good bonds and may be somewhat more expensive than the others. However, these factors probably will not be too important if markedly increased bearing performance results. With this construction a load of, roughly, 1800-2000 psi is permissible depending, of course, on the thickness of the surface layer, and the wear is relatively low.

The use of electrodeposition as a means of applying thin bearing linings also shows definite possibilities. By this means the danger of warping the backing is minimized because of the low temperatures, so coverage will probably be fairly uniform. In addition, it appears that electrodeposited metals have bearing characteristics which are in many cases superior to those of metal applied by fusion methods. The reason for this is not clear as yet. In some instances electrodeposited pure metals can be used for bearings, and in others a suitable alloy can be deposited directly. The method of depositing successive pure metal coatings and then alloying them by diffusion during a heat-treatment also has been used successfully.

#### FABRICATION OF BEARING METALS

Bearings of all types generally are made by some form of casting process, depending on the properties of the materials and the type of installation. The higher melting copper-alloy bearings, unless they are of the type known as *bushings*, i.e., nonferrous shells placed around a steel member so it will not rub directly against another steel member, generally are made by casting followed by subsequent machining. Consequently, these alloys must possess usually some free-machining as well as some bearing characteristics. This is one reason for the lead content of most bearing bronzes, although lead also seems to serve as a true lubricant in these alloys as, without it, seizure takes place when the oil film is broken.

The white metals are formed by gravity casting, die casting, or centrifugal casting as well as by strip casting, i.e., dipping or casting on a continuous strip of metal followed by continuous controlled solidification, de-

<sup>5</sup> This method is described more fully by A. L. Boegehold in Chap. 47 of Ref. 8 at the end of this chapter.

pending upon the form of bearing. Any of these methods can be used readily because of the relatively low melting points of these alloys.

A more or less recent development is the use of powder metallurgy in the production of bearings and bushings. Carefully prepared metallic powders are mixed together in the correct proportions, compressed into the shape desired, and then sintered together at an elevated temperature which may be either above the melting point of one or more of the components, or well below the melting points of any of them. The powders will compact and alloy together, giving a solid piece which can be made to have almost any density by varying the forming pressure and the sintering conditions. This process is discussed further in Chaps. VIII and X.

Bearings can be made by this method which contain almost any amount of voids. These can be saturated with oil by soaking, thus giving a bearing which may run for long times without the use of any added oil. *Oilless bearings* also can be made by adding to the mix a relatively large percentage of graphite, lead, or some other material which has good bearing properties under most conditions of operation. Both the oil-saturated and the oilless bearings are used quite widely for applications in which they must be placed in positions difficult to lubricate properly.

#### TIN-BASE ALLOYS

The tin-base *babbitts* were probably the most widely used bearing metals before World War II, although this condition might change in the future if world economic realignments bring about a permanent shortage or a marked increase in the price of tin. The babbitts are essentially alloys of tin, antimony, and copper, although lead is added in some of the cheaper and poorer alloys. The structures of the alloys are dependent upon the constitutional diagram, which is probably ternary or even more complex and thus difficult to interpret readily, and upon the conditions of cooling. In general, there are three common constituents:

1. A *secondary solid solution* based on the intermetallic compound,  $SbSn$ , which appears in the form of white cubes, and has the general characteristics typical of such compounds, even though it is softer than most of them. This constituent rarely is found in tin babbitts containing less than about 8% antimony.
2. A needlelike constituent which is much harder than  $SbSn$  and is probably the *intermetallic compound*  $CuSn$  or a secondary solid solution based upon it.
3. A *primary solid solution* of copper and antimony in tin which always ex-

hibits a fine precipitate of SbSn and probably also CuSn, and, hence, may appear light or dark depending upon the exact structure and the etching technique used.

A dark appearing constituent which is claimed by some to be either a true eutectic or a constituent having a similar appearance, viz., a *pseudo-eutectic*, has been reported in these alloys,<sup>6</sup> but generally it is believed to be merely an etching effect, possibly resulting from coring or precipitation of certain impurities. It does not appear in pure ternary alloys.

These alloys conform to the general concepts of ideal bearing structures with hard compounds in a relatively soft solid solution matrix. The presence of the needlelike CuSn phase tends to inoculate the SbSn, and thus gives many more and smaller particles of this constituent than would be found in the lower copper alloys. It is claimed by some that the copper also prevents the gravity separation of the SbSn. Needles of CuSn frequently are found within the SbSn cubes as illustrated in Fig. 520a. Rapid cooling, such as in chill casting, tends to suppress the separation of SbSn and thus gives alloys whose structures may show either no SbSn cubes or else relatively small ones, depending on the composition. The shape and general distribution of both the CuSn and the SbSn particles can be influenced by controlling the cooling rate and the pouring temperature. This is illustrated by a comparison of the three photomicrographs shown in Fig. 520.

Long-time service at elevated temperatures will give effects similar to annealing, but these seem to result more from the action of diffusion than from recrystallization or from any change in grain size. They lead to a coalescence of the compounds and the production of a more homogeneous matrix. The cubes of excess SbSn frequently will be partially spheroidized, and various constituents, which are dissolved partially in the matrix in the initial condition, will tend to precipitate from the solid solution as equilibrium is approached. The significance of all these changes with reference to bearing characteristics is very little understood, especially since there is a marked difference between the shape and size of the specimens usually studied metallographically and those of commercial bearing linings.

#### EFFECTS OF IMPURITIES

Arsenic and zinc are limited in tin-base babbitt metals because of their tendency to increase the resistance to deformation, especially at tempera-

<sup>6</sup> See, for example, O. W. Ellis, *Metals Handbook*, A.S.M., 1939, 1709.

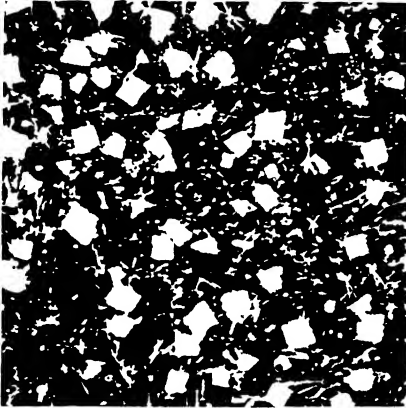
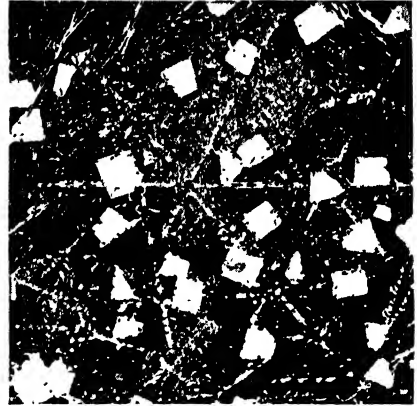


FIGURE 520. Metallographic structure of a tin-base babbitt containing approximately 86% Sn - 10% Sb - 4% Cu. Etched with nital.  $\times 100$ .

*a.* (Upper left) Cast from 1200 F (650 C) into a heated mold. (Photomicrograph by R. P. Stemmler.)

*b.* (Upper right) Cast from 840 F (450 C) into a heated mold. (Photomicrograph by R. C. Altman.)

*c.* (Lower) Cast from 840 F (450 C) into a chill mold. (Photomicrograph by J. Caum.)

tures above 100 F (38 C). Zinc tends also to cause a color change from reddish to white even when present in amounts as small as 0.03%, and to cause a coalescence of the SbSn cubes. Hence, it is kept as low as possible.

Even 1% aluminum will tend to modify the structure and make the cubes disappear. It also tends to cause segregation of copper and antimony on slow cooling so it should be eliminated if possible.

Bismuth is limited because it forms a tin-bismuth eutectic which melts at 280 F (137 C), and thus would lower the strength of the bearing appreciably at temperatures above this.

Lead is kept low in the high tin alloys because it would tend to form a lead-tin eutectic which melts at 360 F (183 C), and thus would decrease the strength above this temperature seriously. In the higher lead alloys, in fact, the formation of this eutectic is the main factor which limits their use, and for this reason the *highly leaded tin-base babbitts* definitely are not to be recommended as a means of conserving tin.



*White Metal Bearings for Heavy Duty*

## SOFT BABBITT

Typical soft babbitts are similar to alloy No. 1 in A.S.T.M. Tentative Standard B23-T, and S.A.E. No. 10. They have a nominal composition of 91% Sn – 4.5% Sb – 4.5% Cu, although some variation is permitted. Impurities are limited to maximum values of 0.35% lead, 0.08% iron, 0.10% arsenic, 0.08% bismuth, and no zinc or aluminum. Structures are roughly similar to that shown in Fig. 521a even though this alloy is a different type. The alloy is used for both bronze-backed and die-cast bearings. It melts at 435 F (225 C), and will have the following approximate mechanical properties:

TENSILE STRENGTH, PSI		YIELD STRENGTH (0.125% RED. OF GAUGE LENGTH), PSI		JOHNSON'S APPARENT ELASTIC LIMIT,* PSI		BRINELL HARDNESS (10 MM-500 KG)	
70 F	210 F	70 F	210 F	70 F	210 F	70 F	210 F
12,850	6,950	4,400	2,650	2,450	1,050	17	8

\* The unit stress at the point where the tangent to the stress-strain curve is 1.5 times its slope at the origin.

The soft babbitts have the lowest hardness and strength of any of the tin-base babbitts.

Among the commercial alloys of this general type are *Genuine Sovereign Babbitt*, *Johnson Bronze Babbitt No. 10*, *Hoyt's Genuine A*, *More Jones Hoo Hoo*, *Phoenix*, and *Navy Antifriction Metal Grade 1*.

## HARD BABBITT

The hard babbitts contain more copper and antimony than the soft babbitts, and are typified by alloys Nos. 3 and 2 in A.S.T.M. Tentative Standard B23-T, and by S.A.E. Nos. 11 and 110. The latter alloy calls for a nominal composition of 89% Sn – 7.5% Sb – 3.5% Cu with impurities as specified for the soft babbitt. This corresponds closely to the patented analysis of the original alloy. Alloys of this type are used, in particular, for certain connecting rod- and shaft bearings in applications requiring somewhat higher pressures than those for which the alloys lower in copper and

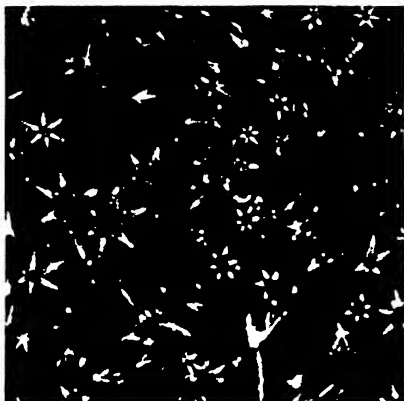


FIGURE 521. Metallographic structures of tin-base babbitts.

a. (Left) 89% Sn – 3.5% Cu – 7.5% Sb. S.A.E. No. 110, from an automotive bearing. Etched with  $\text{FeCl}_3$  in alcohol.  $\times 500$ . (Photomicrograph courtesy The Cleveland Graphite Bronze Company.)

b. (Right) 87% Sn – 6.5% Cu – 6.5% Sb, S.A.E. No. 11. Etched with nital.  $\times 500$ . (Photomicrograph by L. Litchfield.)

antimony would be used. They are also suitable for die casting. Typical mechanical properties are:

TENSILE STRENGTH, PSI			ELONGATION, %			BRINELL HARDNESS (10 MM–500 KG)		
80 F	210 F	300 F	80 F	210 F	300 F	80 F	210 F	300 F
10,900	5,700	3,100	11.5	31.2	53.0	25.5	14.0	9.2

Figure 521 shows metallographic structures of two of these compositions. The starlike CuSn constituent is readily recognizable in a tin-rich solid solution background. Any SbSn present is in the form of fine particles precipitated from solid solution.

Among the commercial brand names for alloys of this type are: *Genuine Babbitt*, *Acorn Brand*, *Johnson Bronze Babbitt No. 11*, *British Navy Antifriction Metal*, *Genarco Connecting Rod*, *D-2*, *Interurban No. 27*, *Stannum*, *Hewitts Fine*, *More Jones Nickel*, and *Navy Antifriction Metal Grade 2*.

#### HEAVY-DUTY LEAD-BASE BABBITT

The alloy most widely used for steel-backed automotive bearings is a heavy-duty lead-base babbitt containing, nominally, 82.5% Pb – 15% Sb –

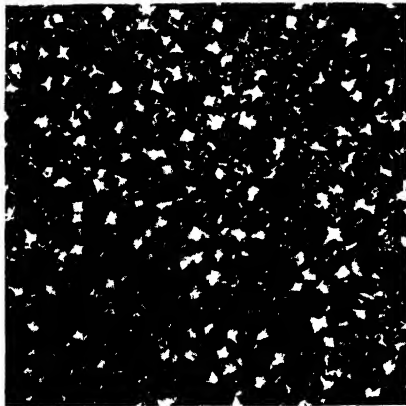


FIGURE 522. Metallographic structure of a heavy-duty lead-base babbitt, S.A.E. No. 15, containing 82.5% Pb - 15% Sb - 1% Sn - 1% As - 0.5% Cu, as strip cast for automotive service. Etched with dilute HCl.  $\times 500$ . (Photomicrograph courtesy The Cleveland Graphite Bronze Company.)

1% Sn - 1% As - 0.5% Cu and covered by A.S.T.M. Tentative Standard B23-T (alloy No. 15) and S.A.E. No. 15.<sup>7</sup>

The main advantage of this alloy, other than its low cost and availability, is its fatigue resistance which is at least equal to that of the tin-base babbitts. Impurities of aluminum and zinc, in particular, must be controlled carefully and a maximum of 0.005% is set for them. Other impurities are less important and are held within 0.35%.

In addition to its fatigue resistance this alloy shows a better retention of mechanical properties at elevated temperatures than the tin babbitts.

For use, this lead-base alloy is bonded to steel strip, by one of the methods mentioned earlier, either in a thickness

of 0.010-0.0625 in., for conventional bearings capable of withstanding

TENSILE STRENGTH, PSI			ELONGATION, %			BRINELL HARDNESS (10 MM-500 KG)		
80 F	210 F	300 F	80 F	210 F	300 F	80 F	210 F	300 F
9,600	6,500	4,100	1.2	4.8	15.5	20.8	14.2	9.8

maximum mean unit pressures of about 1200 psi, or in a thickness of 0.002-0.005 in., for microbearings which will give satisfactory service under maximum mean unit pressures of about 1800 psi.

The metallographic structure of the alloy, shown in Fig. 522, consists of primary particles rich in antimony in a background composed of lead-antimony pseudo-binary eutectic and a complex eutectic. The minor constituents occur in solid solution in one or the other of these constituents.

Commercially this alloy is known as *Boveall Babbitt*, *S-Metal*, *F-23*, or by its A.S.T.M. or S.A.E. designation.

#### CADMIUM-BASE ALLOYS

The cadmium-base bearings are relatively recent developments and in-

<sup>7</sup> See also, R. G. Thompson, *Metal Progress*, 46, 1944, 739-742.

clude the cadmium-nickel alloys and the cadmium-silver and cadmium-silver-copper alloys.

#### CADMIUM-NICKEL BEARING ALLOYS

The cadmium-nickel bearings,<sup>8</sup> containing anywhere from 0.5–3% nickel, are the only white metal bearings used at the present time for linings in heavy-duty sliding-type bearings. The S.A.E. No. 18 alloy contains 1–1.5% nickel and a minimum of 98.5% cadmium, and consists of a matrix of an eutectic, containing about 0.25% nickel and composed of cadmium and the compound NiCd<sub>7</sub>, and about 16% excess NiCd<sub>7</sub> in the form of cubes, skeleton cubes, or dendrites. These constituents are easily identified in the typical micrographs shown in Fig. 523a and b. *Asarco-Loy* and *F-3* are commercial alloys of this type.

Bearings of this composition are bonded directly to an iron or steel backing. They are believed to form the second type of bond mentioned previously, some nickel first dissolving in the steel backing and then alloying with the cadmium to make the bond.

The physical and mechanical properties of these alloys are good and include a high melting temperature and a high fatigue resistance, both advantageous for heavy-duty sliding-type bearings.<sup>9</sup>

	TENSILE STRENGTH, PSI			YIELD STRENGTH, PSI		
	80 F	210 F	575 F	80 F	210 F	575 F
1.3% Ni	16,400	10,500	600	11,700	—	—
3% Ni	22,900	14,300	700	16,800	—	—

	ELONGATION, % IN 2 IN.			HARDNESS					
	80 F	210 F	575 F	BRINELL (10 MM–500 KG)			ROCKWELL ( $\frac{1}{4}$ –100–B)		
	80 F	210 F	575 F	80 F	210 F	575 F	80 F	210 F	575 F
1.3% Ni	19	36	162	33	22	1.8	65	—	—
3% Ni	6	13	213	48	28	1.9	84	—	—

<sup>8</sup> These are discussed further by A. J. Phillips, *Product Eng.*, 6, 1935, 365.

<sup>9</sup> For a comparison with other white metal bearing alloys see C. E. Swartz and A. J. Phillips, *Proc. A.S.T.M.*, 33, 1933, 416.

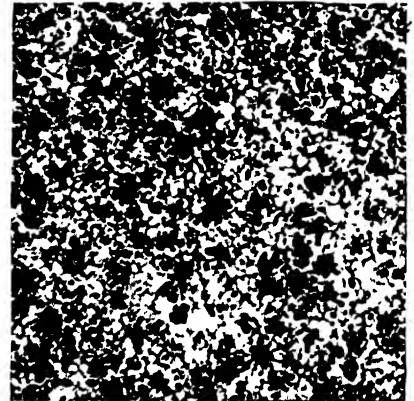
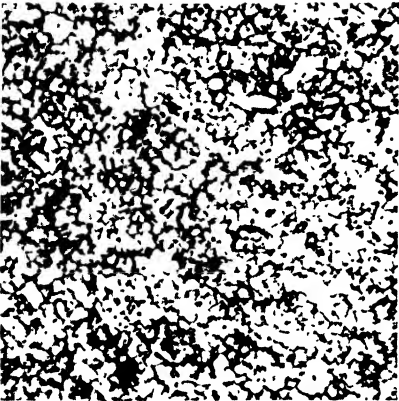
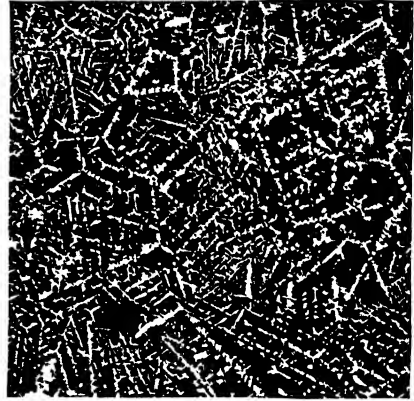
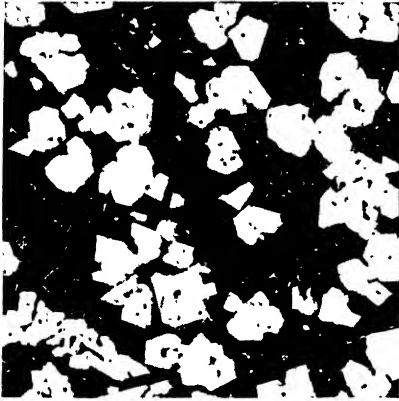


FIGURE 523. Metallographic structures of cadmium-base bearing alloys.

*a.* (Top left) Asarco-Loy, cadmium-nickel bearing alloy (97% Cd - 3% Ni), taken from a rolling-mill bearing. Etched with HAc + H<sub>2</sub>O<sub>2</sub>.  $\times 100$ . (Photomicrograph courtesy Research Department, American Smelting and Refining Company.)

*b.* (Top right) Cadmium-nickel automotive bearing (98.75% Cd - 1.25% Ni).  $\times 100$ . (Photomicrograph courtesy The Cleveland Graphite Bronze Company.)

*c.* (Middle left) Cadmium-silver bearing alloy containing approximately 98.75% Cd - 0.75% Ag - 0.50% Cu. Etched with nital.  $\times 100$ .

*d.* (Middle right) Cadmium-silver bearing alloy containing approximately 96.25% Cd - 3% Ag - 0.75% Cu. Etched with nital.  $\times 100$ . (Photomicrographs *c* and *d* by L. Litchfield.)

*e.* (Bottom) An automotive bearing similar to *c*.  $\times 500$  originally; reduced about one third in reproduction. (Photomicrograph courtesy The Cleveland Graphite Bronze Company.)

The solidification range lies between about 605 F (320 C), the eutectic temperature, and 740 F (395 C) for the 1.3% nickel alloy or 860 F (460 C) for the 3% nickel alloy.

#### CADMIUM-SILVER AND CADMIUM-SILVER-COPPER BEARING ALLOYS

The cadmium-silver alloys were one of the first results of intensive efforts to develop bearings which had superior qualities. Previous efforts had been directed largely toward cheaper substitute alloys, but trends toward higher speeds and temperatures in internal combustion engines focused attention on the need for a more modern viewpoint. The relatively high melting points and the compound formation in these alloys prompted their selection for study.

Silver dissolves in cadmium in amounts up to about 2.5% and above this forms the compound  $\text{AgCd}_3$ . Copper is only slightly soluble and forms an eutectic, at about 98.9% cadmium, between the cadmium-rich  $\eta$  solid solution and an  $\epsilon$  solid solution which probably is based upon the compound  $\text{CuCd}_3$ . Thus the hard particles of a compound can be secured much more cheaply by using copper than silver.<sup>10</sup> Copper alone will harden and strengthen cadmium but only at the expense of ductility and toughness. The addition of silver, however, gives cored grains of the cadmium-silver solid solution which results in a much better combination of strength, hardness, and ductility. As a result, most of the commercial *cadmium-silver bearings* are really cadmium-silver-copper alloys, containing 0.50–2.25% silver and 0.25–0.50% copper.

A common example, S.A.E. No. 180, contains 0.5–1% silver, 0.4–0.75% copper, and a minimum of 98.25% cadmium. The structure of a commercial alloy of this type *CS-50* (98.75% Cd–0.75% Ag–0.50% Cu), Figs. 523*c* and *e*, consists largely of cored grains of the cadmium-rich solid solution surrounded by the cadmium-copper-silver eutectic which is darker in color. The small particles of the intermetallic compounds can be seen as white crystals in the complex matrix. Another commercial alloy *CS-53*, containing 96.25% Cd–3% Ag–0.75% Cu (Fig. 523*d*), has a structure similar to that of *CS-50*, and is somewhat harder and stronger.

The high melting range of these alloys, about 600–620 F (315–325 C), enables them to be used at much higher operating temperatures than are possible with the other white metal alloys. From the mechanical properties listed on p. 816, it can be seen that they hold up very well even at 400 F (200 C). For best results, however, the impurities must be kept to a minimum, especially tin, antimony, lead, zinc, and any metals that tend to give lower

<sup>10</sup> See C. F. Smart, *Trans. A.S.M.*, **25**, 1937, 571–602.

melting eutectics. In particular, solders containing these elements must not be used:

TENSILE STRENGTH, PSI			ELONGATION, % IN 2 IN.			BRINELL HARDNESS (10 MM-500 KG)		
70 F	210 F	400 F	70 F	210 F	400 F	70 F	210 F	400 F
18,000	11,800	4,350	50	44	68	40	19	8.1*

\*10 mm-125 kg

Although these alloys tend to be corroded somewhat by lubricating oils, particularly when operating at relatively high temperatures, this can be prevented or minimized by several different methods, and is not a serious problem. The alloys also can be deposited electrolytically if desired, giving the same constituents. They are used only in steel-backed bearings, their bond strength being appreciably better than that of the tin- or lead-base alloys.

#### ZINC-BASE BEARING ALLOYS

Only a few zinc-base bearing metals have been used at all and these only to a limited extent in applications where speeds are high and loads are steady and free from shock, such as in spindle bearings for high-speed lathes and other machine tools, and electric motors. The alloys fall within the composition range 85–88% zinc, 4–10% copper, and 2–8% aluminum, and are fairly hard, Brinell 120–132, and brittle. The ultimate tensile strength, yield point, and elastic limit are all about 31,000–36,000 psi with no measurable elongation or reduction in area so the alloys should not be used where shock or impact is involved.

The metallographic structure of a chill-cast specimen consists primarily of hard starlike particles of a secondary solid solution, probably containing zinc, copper, and some aluminum, embedded in a finely dispersed eutectic mixture of a zinc-rich  $\alpha$  primary solid solution and an aluminum-rich  $\beta$  primary solid solution. A slowly cooled specimen consists of relatively large white particles of the  $\alpha$  primary solid solution of copper and aluminum in zinc in a coarsely lamellar matrix consisting of the zinc-rich  $\alpha$  and the aluminum-rich  $\beta$  primary solid solution phases. These constituents can be recognized readily in Fig. 524. *Lumen Bronze* and *Sampson Metal* are commercial alloys of this type.

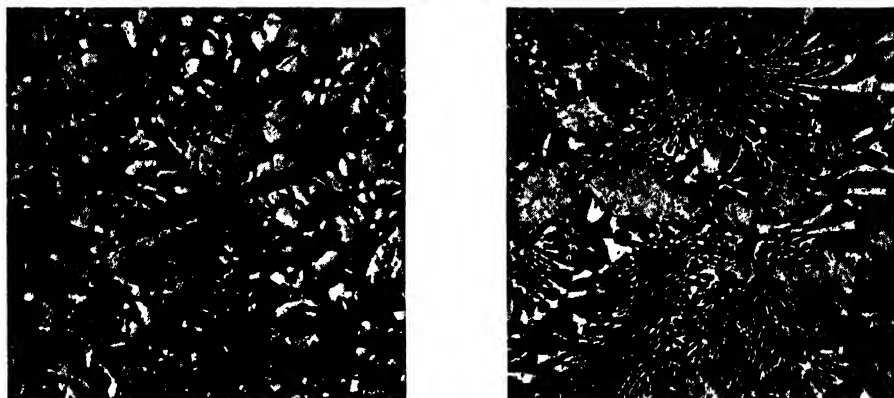


FIGURE 524. Metallographic structures of a commercial zinc-base bearing alloy, Lumen bronze, containing approximately 86% Zn - 10% Cu - 4% Al. Etched with 10% HNO<sub>3</sub>.  $\times 200$ . (Photomicrographs courtesy Lumen Bearing Company, Buffalo, N. Y.)

*a. (Left)* Poured into a chill mold.

*b. (Right)* Slowly cooled in a sand mold. The massive particles of aluminum-rich solid solution have decomposed somewhat because of an eutectoid reaction.

In general, zinc-base alloys are not favored for bearings because of their tendency to seize when lubrication is inadequate or when they are not properly designed and fitted.

#### ALUMINUM-BASE BEARING ALLOYS

Development of aluminum-base alloys for bearings has been underway in Germany and England for many years. Until about 1937, however, most of the development was directed along conventional lines, viz., hard particles embedded in a soft matrix, and usage generally was limited to applications involving light loads, service against hardened steel shafts, and good lubrication. In this country work has been directed toward a solid aluminum-alloy bearing, a steel-backed aluminum bearing, and a powdered aluminum-alloy bearing.

Although data on these materials still is limited, the most promising of the solid aluminum bearing alloys seem to be 6.5% Sn-2.5% Si-1% Cu-0.5% Ni-rem. Al and 6.5% Sn-1% Ni-1% Cu-rem. Al (*Alcoa No. 750*). These are used chiefly as permanent mold castings and as sand castings although work on die castings has been progressing also. Typical properties for the permanent mold cast form after heat treatment (-T533), viz., artificial aging without prior solution treatment would be



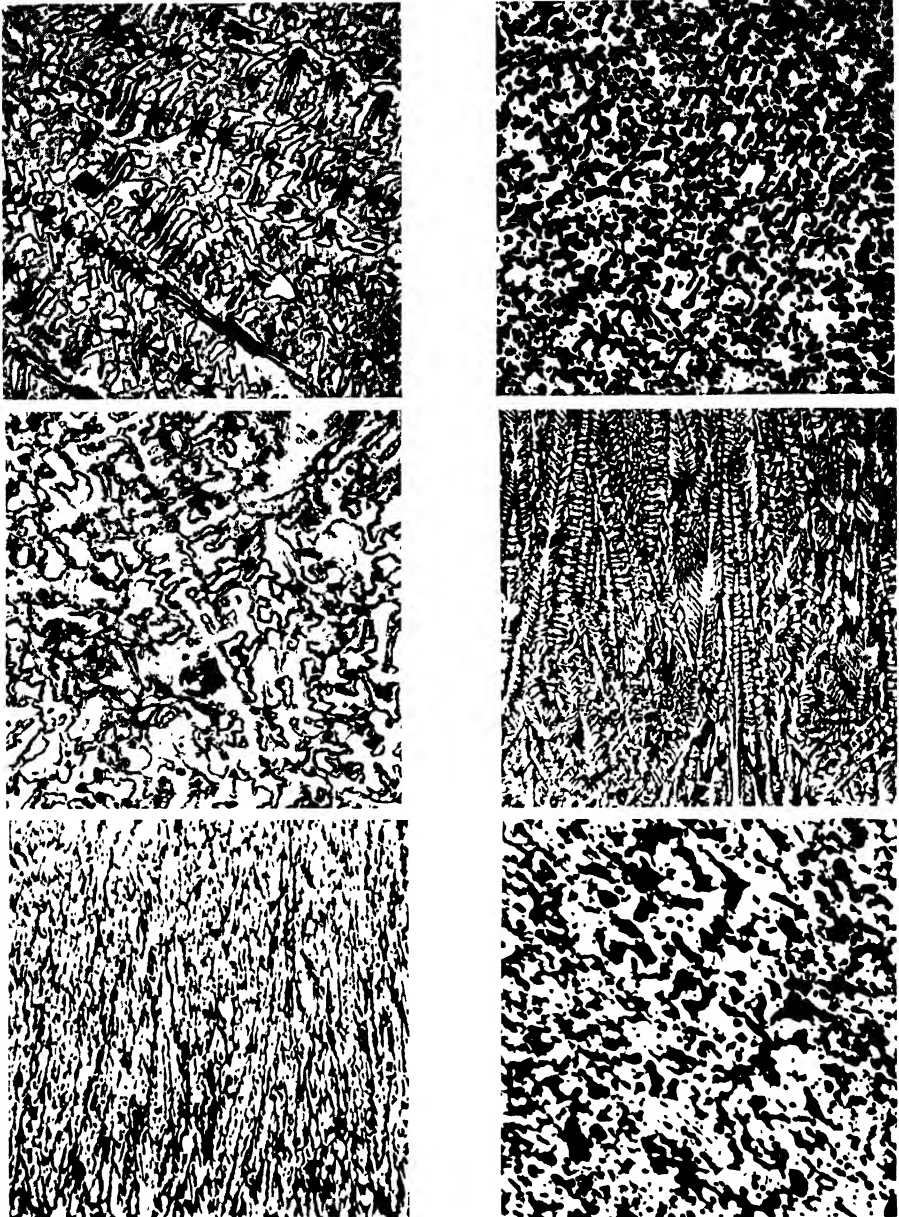


FIGURE 525. Metallographic structures of some cast copper-base bearing alloys.  
*a.* (Top left) Bell metal (80% Cu - 20% Sn), showing particles of secondary solid solution ( $\text{Cu}_4\text{Sn}$ ) in a matrix of cored copper-rich  $\alpha$  solid solution. Etched with  $\text{NH}_4\text{OH} + \text{H}_2\text{O}_2$  and Grard's No. 1.  $\times 200$ . (Photomicrograph by G. W. Brown.)  
*b.* (Top right) Bearing bronze (80% Cu - 10% Sn - 10% Pb). Etched with  $\text{NH}_4\text{OH} + \text{H}_2\text{O}_2$ .  $\times 50$ . (Photomicrograph by L. C. Cavalier.)  
*c.* (Middle left) Gun metal (88% Cu - 10% Sn - 2% Zn). Etched with  $\text{NH}_4\text{OH} + \text{H}_2\text{O}_2$ .  $\times 100$ . (Photomicrograph by J. H. Dedrick.)

Tensile strength, psi	20,000
Yield strength (0.2% offset), psi	8,500
Elongation, % in 2 in.	10
Brinell hardness (10 mm–500 kg)	45
Fatigue endurance limit, psi	9,000

The ability of the alloys to resist scoring and seizing under emergency conditions is at least as good as any of the conventional bearing materials. However, these alloys will not, in general, embed foreign particles as well as the babbitts.

Binary aluminum-tin alloys containing 6–10% tin have worked well for steel-backed bearings. When they are used in thicknesses comparable to the babbitt bearings of this type, they have operated at higher temperatures and have shown more than twice the load carrying capacity of the babbitt-type bearings. Two varieties of steel-backed bearings have been developed. In the *Al-Fin* type the aluminum alloy is cast against the prepared surfaces of desired lengths of steel tubes. These lined shells are then machined and either used as rounds or split to make bearing halves. Bushings and flanged bearings are made in a similar manner. In the *P. R. Mallory & Co.* type the steel backing is in sheet or strip form and the bearing is formed, after the alloy is bonded to the strip, by any of the usual methods and machined to size.

Little is known as yet about the powdered aluminum bearings. Self-lubricating bearings of this type developed during World War II gave performances at least equal to self-lubricating bronze bearings. However, their comparatively high cost and certain production difficulties which were encountered have prevented their use for heavy-duty service thus far.

### *The Bearing Bronzes*

The bearing bronzes are alloys of copper with varying amounts of tin, lead, and sometimes a small amount of zinc.<sup>11</sup> The original alloys of this

<sup>11</sup> This general subject is discussed thoroughly by D. P. C. Neave and W. B. Sallitt, *Inst. Mech. Eng.*, General Discussion on Lubricants, 1937, (Group I) 190–197; also *Met. Ind.*, London, 51, 1937, 377–380.

*d. (Middle right)* Cross section of gravity-cast copper-lead bearing alloy, S.A.E. No. 48 (70.5% Cu – 28.5% Pb – 1.25% Ag), used for aircraft bearings. Unetched.  $\times 100$ . Note the tendency for branches to develop in the wide dendrites. (Photomicrograph courtesy The Cleveland Graphite Bronze Company.)

*e. (Bottom left)* Cross section of strip-cast copper-lead bearing alloy, S.A.E. No. 480 (65% Cu – 35% Pb), used for automotive bearings. Unetched.  $\times 100$ . Note the very thin and needlelike dendrites, and the absence of branches. (Photomicrograph courtesy The Cleveland Graphite Bronze Company.)

*f. (Bottom right)* Graphite bronze bearing (89% Cu – 10% Sn – 1% C) made by powder metallurgy. Etched with  $\text{NH}_4\text{OH} + \text{H}_2\text{O}_2$ .  $\times 200$ . Cf. Fig 172.

type were the 80% Cu-10% Sn-10% Pb alloy, introduced in England about 1880, and the alloy introduced in this country about 1892 by Dr. Dudley, of the Pennsylvania Railroad, which analyzed 77% Cu-8% Sn-15% Pb (*Ex-B metal* or *Engine brass*). Both of these alloys still are used extensively.

The bearing bronzes may contain 5-20% tin although the range 10-12% is most common. Under these conditions the alloys will be composed of a matrix of  $\alpha$  copper-tin solid solution in which are embedded hard particles of the  $\delta$  ( $\text{Cu}_4\text{Sn}$ ) secondary solid solution (Fig. 525a). All copper-tin alloys containing more than about 5% tin will show these constituents, especially in the as-cast condition. Increasing the tin content is accompanied by an improvement of structural strength and resistance to deformation by pounding, but with more than 12% tin the alloys tend to become hard and brittle and are rather difficult to machine. It must be remembered, in this respect, that although any added lead is essentially insoluble in the copper-rich phase, a considerable portion of the tin will go with the lead and this may be significant if the lead is high. The real criterion of tin content is, therefore, not necessarily either the tin:copper ratio or the actual percentages of these elements.

Phosphorus, if present, is added to deoxidize and improve the casting qualities. This decreases the amount of tin oxide, a constituent which is very hard and liable to cause scoring. Phosphorus in the range 0.1-0.5% tends to form the very hard compound,  $\text{Cu}_3\text{P}$ , which hardens the bearing but may render it brittle.

Lead should be kept in as fine a state of dispersion as possible by agitation before casting or by the use of suitable addition agents, and by careful control of the casting procedure and the cooling rate. The smaller the particles the better the effect. Lead imparts to the bearings a much greater plasticity than the lead-free alloys possess, and also permits them to function for limited periods if the lubrication should be inadequate, thus giving a certain factor of safety. Amounts of 1-2% frequently are added to cast tin bronzes to increase machinability, and amounts greater than 5% to reduce the dry coefficient of friction. Although lead up to 12% improves plasticity, it also reduces the shock resistance as well as the resistance to deformation by pounding.

Zinc, when present, acts as a deoxidizer and permits the omission of phosphorus. However, some authorities claim it also gives a tendency toward seizing and tearing of the bearing surface. Consequently, it is probably of little advantage except for its effect on the casting qualities. In particular, it does not seem to affect the wearing qualities, at least in amounts up to 4%.

Nickel sometimes is added in amounts of less than 2% to give some increase in the wearing qualities. It also tends to refine the structure of the casting somewhat and to reduce the segregation of lead.

The total impurities other than alloying elements should be kept below 0.5%, largely because of the deleterious effects of some of them on the mechanical properties and casting characteristics and in order to have a better control over the amounts of scrap used in the melt.

#### COPPER-TIN-LEAD BRONZES

The original bearing bronze containing 80% Cu-10% Sn-10% Pb is typical of a series of alloys now in use. Castings of this composition are covered by A.S.T.M. Tentative Standard B144-T (alloy No. 3A) and S.A.E. Nos. 64 and 792.

There are normally about 230 commercial bearing bronzes being manufactured, comprising about 80 different alloys. Nearly 57 different specifications are used to cover them even when all duplicates are eliminated. The bronzes of this group include alloys containing 70-85% copper, 5-10% tin, and 5-25% lead. A few also contain some zinc. Their metallographic structure, shown in Fig. 525*b*, is similar to that of a cast copper-tin alloy except for the globules of insoluble lead. These comprise the most important bearing bronzes which are not lined with white metal, and also the important bronze bearing backs. Because of their very high melting points these alloys can be and are used at much higher temperatures, determined largely by the melting of the included lead, than most of the other bearing alloys. Some of the properties of the 80:10:10 alloy are:

TENSILE STRENGTH, PSI	ELASTIC LIMIT, PSI	ELON- GATION, % IN 2 IN.	REDUC- TION IN AREA, %	BRINELL HARDNESS (10 MM-500 KG)				
				75 F	150 F	250 F	350 F	450 F
36,500-44,000	10,000-13,000	23-41	21-34	64	61	59	58	56

Among the commercial names under which this composition is sold are: *Magnolia Bearing Bronze*, *Lumen Alloy No. 4*, *F-17*, and *F2 Bearing Bronze*.

#### NICKEL-ANTIMONY-LEAD BRONZES

Two alloys, containing respectively 8% Ni-1% Sb-10% Pb-1% Zn-80% Cu and 8% Ni-1% Sb-10% Pb-1% Zn-2% Sn-78% Cu, have re-

cently been developed as substitutes<sup>12</sup> for the usual 80:10:10 bearing bronzes. Their chief advantages over the standard alloy appear to be a lower metal cost and a better wear resistance as judged by laboratory tests. In addition, they contain little or no tin, a factor which would make them very important in times when this strategic element is too expensive or difficult to secure.

These nickel-antimony-lead bronzes have a good castability but their strength properties, tensile strength 20,000–25,000 psi, yield strength 13,000–18,000 psi, elongation 4–6%, are somewhat poorer than those of the 80:10:10 composition given previously.

The materials are as yet too new to determine fully how well they will compete with the older alloys, but preliminary tests with them seem very promising.

#### COPPER-TIN-ZINC BRONZES

The bronzes of a 90% Cu–10% Sn base are used themselves to some extent for bearings, sometimes with up to 4% zinc added to improve their casting qualities and up to 2% lead to improve their machinability. These alloys are used primarily for applications requiring heavy loads, when lubrication is good. They also were discussed briefly in Chap. XIV.

The structure of the 88:10:2 alloy (Fig. 525c), except that it contains no lead, is quite similar to that of the cast tin bronzes since the zinc is soluble in the  $\alpha$  copper-tin solid solution. The mechanical properties, however, will average appreciably higher than those of the bearing bronzes, ultimate tensile strengths of 45,000 psi, and elastic limits of 12,000 psi being readily obtainable combined with good elongations and reductions in area.

Commercially these alloys are known as *Government Bronze*, *Composition G* (lead-free), *Commercial G* or *Composition M* (leaded), *Gun Metal*, and *Admiralty Gun Metal*. Photomicrographs also are shown in Fig. 416 for some of them.

#### COPPER-LEAD BRONZES

The copper-lead alloys, sometimes known as the *lead bronzes*, generally contain, nominally, either about 70% Cu–30% Pb (S.A.E. No. 48), or 65% Cu–35% Pb (S.A.E. No. 480), although other analyses are used. It is difficult with these alloys to secure a uniform distribution of the lead throughout the copper unless the casting and cooling are controlled very carefully. This can be done readily by continuous casting, particularly in the A.S.&R.

<sup>12</sup> For a complete description of these alloys, see J. T. Eash, *A.I.M.E. T.P. 1937, Metals Technology*, 12, No. 8, 1945.

Process discussed in Chap. X. Many other methods have been tried to accomplish this, and many patented, but most of them have advocated the use of various addition agents in the liquid bath. Three additions which have given good results are illustrated by S.A.E. No. 481 (72% Cu-25% Pb-3% Sn), S.A.E. No. 482 (71% Cu-25% Pb-3% Sn-1% Ni), and a modification of the S.A.E. No. 48 alloy (71% Cu-28% Pb-1% Ag) which is finding considerable use in the airplane industry because of its increased mechanical strength over the 35% lead alloy. Fig. 525*d* shows the dendrites perpendicular to the bond surface in a typical gravity-cast aircraft bearing structure of this latter type. In addition, an entire series of alloys containing, nominally, 70% copper, 5-10% tin, 20-25% lead is sold commercially under a variety of names.<sup>13</sup>

A process which has been used extensively for many types of automotive bearings consists of casting molten copper-lead alloy on a mild steel strip about 1/16 in. thick, and subsequently cooling under conditions which will give the structure desired (Fig. 525*d*). The coated strip is then subjected to various finishing operations and formed into semicylindrical half bearings.<sup>14</sup>

The copper base in this bearing alloy permits heavy service and the lead lubricates and offers pockets for holding the oil. However, the melting point of the lead, 625 F (330 C), restricts the operating range, and the alloy is susceptible to corrosion over a wide range of temperatures. With respect to conformability and embeddability these alloys are inferior to the white metal bearings.

When properly made, they have a relatively high load-carrying capacity, maximum mean unit pressures of 1800-2000 psi are consistent with long life, even though their Brinell hardness is only about 30. Their thermal conductivity is relatively high, as would be anticipated. However, because of their softness, only a thin layer, averaging 0.02-0.06 in., chill cast on a thin backing generally is used<sup>15</sup> in order to minimize the possibility of spreading under load.

Mild steel is the usual shell material since tempered steel would tend to soften at the temperatures needed. The welded bond is very good, and they have an excellent fatigue resistance.

Among the commercial names under which these alloys are sold are: *Bearium*, *Cu-Lead-Ite*, *Lumen Alloy No. 33*, and *Sumet Bronze*, whereas *Steel Back Clevite* is one of the better known bearings of the backed type.

<sup>13</sup> The properties of these alloys as compared with copper-lead alloys has been discussed by F. R. Hensel and L. M. Tichvinsky, *Trans. A.S.M.E. (Iron and Steel)*, 54, 1932, 11-24.

<sup>14</sup> See, for example, *Iron Age*, 136, 1935, 24, 47.

<sup>15</sup> See F. G. Jenkins, *Metal Progress*, 32, 1937, 145-149, for a further discussion of these alloys under severe service.

When the 70% Cu–5.5% Sn–24.5% Pb alloy is used by railroads it is known as a *journal brass* because of its use on freight and passenger cars as a backing for a lead-base babbitt journal bearing.

#### GRAPHITE BRONZE

Certain bearings, that would not be possible by ordinary methods, have been produced by the use of metal powders. Such alloys as the true graphite bronzes, a common example of which analyzes: 89% Cu—10% Sn—1% C (graphite), are of this type. These bearings are formed under pressures of 40,000–60,000 psi, and then sintered. They are porous and generally are saturated with oil before using. Consequently, the combination of the oil and the graphite makes them very satisfactory for many applications in which lubrication is apt to be uncertain or absent. However, they must be supported properly. The alloys *Compo*, *Oilite*, *Johnson Bronze Graphited Bearings*, *Durex*, and *Gramix* are of this general type although other additions than graphite are sometimes used. The metallographic structure of typical alloys is shown in Fig. 525f and in Fig. 172. A.S.T.M. Tentative Standard B202-T covers this type of alloy.

Also known as graphite bronzes are certain bearing alloys which are used in the form of split bushings. Indentations are rolled into the inner surface and filled under pressure with graphite paste. The six alloys used most commonly for this purpose are listed in Table XLV.

TABLE XLV CHEMICAL COMPOSITIONS OF ALLOYS COMMONLY USED FOR GRAPHITE BRONZES OF THE SPLIT BUSHING TYPE

	% CU	% SN	% ZN	% PB
A	90	0.5	9.5	—
B	88	4	4	4
C	85	4	3	8
D	67	3.5	2.5	27
E	80	10	—	10
F	94	5	0.35*	1

\* Max

Bearings of this type are used in automotive applications, such as rocker arms, axles, steering knuckles and arms, and piston pins, where the motion is oscillatory.

Alloy B is very similar to the wrought alloy, S.A.E. No. 791, and to the cast red brass alloy 85:5:5:5 (S.A.E. No. 40) both of which are used for split bushings and have been discussed already in Chap. XIV.

#### SILVER-BASE BEARING ALLOYS

Pure silver bearings were developed which had greater strengths than the copper-lead alloys and were unusually seizure resistant in the heaviest duty aircraft service especially when run against polished shafts.<sup>16</sup> However, because of insufficient "oiliness" such bearings were not entirely reliable as they showed some tendency to seize when lightly loaded. By adding 3–5% lead, bearings were produced with sufficient oiliness to overcome this objectionable feature. These have been used successfully in aircraft service, particularly in engine crankshaft bearings. In these applications the alloy customarily is bonded to a steel backing.

Bearings also have been developed in which a thin layer (about 0.002–0.006 in.) of lead or of a 3–4% lead-silver alloy is electrodeposited either directly on the steel backing itself or on a silver base, which may itself be cast or electrodeposited on a steel backing. This direct electrodeposition on steel makes possible a much greater range of hardnesses in the backing than can be secured when silver or the alloy is cast on. After plating, electrodeposited bearings are annealed below 575 F (305 C), the melting point of the lead-silver eutectic, to improve the bond with the backing. Heating for 5 hr at 500 F (260 C) followed by 4 days at 350 F (175 C) is a heat-treatment that has been used satisfactorily. The problem of adequately bonding the alloy to the steel base has been the most troublesome one encountered, but by proper use of "strike" plates before the alloy is deposited and of heat-treatment afterward it has been solved successfully.

To improve the corrosion resistance of the bearing thin layers of indium have been electrodeposited on the surfaces, and then diffused into the alloy by a low-temperature heat-treatment.

#### *White Metal Bearings for Light Duty*

##### LEADED BABBITTS

The leaded babbitt alloys containing 65 or 75% tin, 12 or 15% antimony, 10 or 18% lead, and 2 or 3% copper, A.S.T.M. Tentative Standard B23-T (alloys Nos. 4 and 5), are relatively cheap substitutes, and are intended largely for bearings subjected to moderate pressures and somewhat lower

<sup>16</sup> See R. W. Dayton and C. L. Faust in Chap. 8 of *Silver in Industry*, edited by L. Addicks: Reinhold Publishing Corporation, New York, 1940.



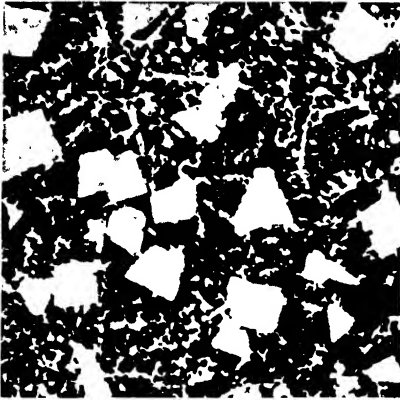


FIGURE 526. Metallographic structure of a highly leaded tin-base babbitt containing approximately 70% Sn - 14% Pb - 14% Sb - 2% Cu. Etched with nital.  $\times 100$ . (Photomicrograph by L. Litchfield.)

them from this viewpoint and the heavy-duty type is preferable and better for almost any application.

Among the commercial brand names for these highly leaded tin-base babbitts are *Marine*, *Hard Genuine*, *Service D*, and *Majestic*. A microstructure typical of them is shown in Fig. 526.

#### LEAD-BASE BEARING METALS

Lead-base bearings of this class are generally of two types. The first contains more than 65% lead and various amounts of antimony and tin, with additions of copper and arsenic in some cases. The second, and more recent type, contains better than 98% lead with the remainder consisting largely of calcium and small amounts of other metals.

#### EFFECTS OF ALLOYING ELEMENTS AND IMPURITIES

Of the elements added to lead, the purpose of the antimony and tin should be reasonably clear by now. The antimony generally is kept between 10% and 15%, and, although some of this will dissolve in the lead matrix along with some of the tin, the majority combines with the tin to form the characteristic  $SbSn$  ( $\beta$  solid solution) cubes. With more than 15% antimony these cubes become quite numerous and almost continuous throughout the structure so the alloy becomes too brittle for use. The lead-rich solid solution furnishes a large part of the strength of the matrix.

operating temperatures than the tin babbitts will withstand. The melting temperatures are lower than those of the regular babbitts because of the presence of a lead-tin eutectic, and the mechanical properties are about midway between those of the hard and soft babbitts. These alloys have been used extensively, but not in the form of thin lined bearings as in this condition they will not meet service requirements. Their lower cost offers a distinct appeal for some applications, but because of the inefficient utilization of tin their use should not be recommended as a means of saving this element. The lead-base bearing metals are superior to

Tin is generally present in amounts greater than 5% but seldom greater than 20% because of its cost and the small advantage it gives above this amount. It is distributed between the lead-rich solid solution and the SbSn compound.

Copper in the range 1–2% tends to prevent tin and antimony segregation resulting from the fact that SbSn cubes are lighter than the matrix and tend to float to the top. The reason for this effect of copper is not entirely understood. In low-tin alloys where this effect is not so important, the copper is limited to 0.5%.

Arsenic also tends to prevent segregation, and refines the structure in general. The cubes appear less readily in the presence of arsenic, probably because of the formation of a ternary constituent which does not crystallize in this form. Arsenic in amounts up to 2.5%, or silver in amounts of 2.6–5.1%, assists in increasing the hardness at both normal and elevated temperatures. Silver additions also appear to assist the bond with the steel backing materially.

#### HIGH-TIN LEAD-BASE BEARING ALLOYS

The A.S.T.M. alloys 6, 7 and 16, S.A.E. No. 14, with 10 or 20% tin, 12.5 or 15% antimony, 63.5 or 75% lead, and 0.2 or 1.5% copper, are typical of the lead-base alloys containing comparatively high amounts of tin.<sup>17</sup>

Their ultimate strength generally is close to 15,000 psi at room temperature and about half that at 212 F (100 C). Brinell hardnesses will be about 21–22 at room temperature and about 10–11 at the higher temperature. With these alloys, the ultimate strength is taken as the stress necessary to produce a deformation of 25% the length of the specimen.

A typical structure in which the constituents are readily recognized is shown in Fig. 527a. The commercial alloys *Lotus*, *Blue Grass High Speed*, *Cutlasta*, *Hoyts Reliance*, *More Jones Crescent*, *Rogers Special Engine*, and *Navy Antifriction Metal Grade 7* are of this general type, and, in steel-backed bearings, *LB-142*, *F-11*, or the S.A.E. designation are commonly used.

#### LOW-TIN LEAD-BASE BEARING ALLOYS

The alloys low in tin, and consequently limited in their copper content, are represented by the A.S.T.M. alloys 8 and 19, S.A.E. No. 13, and the A.A.R. Specification for Journal Bearing Linings, M-501-34. These contain 5% tin, 9 or 15% antimony, 80–86% lead, and a maximum of 0.5%

<sup>17</sup> See also A. J. Phillips, A. A. Smith, Jr., and P. A. Beck, *Proc. A.S.T.M.*, **41**, 1941, 886–893.

copper. The properties of these alloys at room temperature are much the same as those of the higher tin group but at 212 F (100 C) they are somewhat softer and weaker. The commercial alloys *Bermax*, *Aurora Babbitt*, *Mohawk Babbitt*, *Genarco Tractor*, *Special I*, *Anti-Friction*, *More Jones Improved*, *M & E Imperial*, *Magnolia Defender*, *Power*, *Premium High Speed*, *Wings Coin Babbitt*, *L100*, and *Navy Antifriction Metal Grade 6* are of this general type.

A typical microstructure will consist of varying amounts of ternary eutectic (84% Pb-4% Sn-12% Sb) and either excess lead-rich primary solid solution (Fig. 527*b*), or cubes of SbSn depending upon the exact composition.

#### LEAD-ANTIMONY BEARINGS

The lead-antimony bearings are an old series of alloys which are still entirely satisfactory for many uses. The eutectic in this binary system occurs at about 11.5% antimony for very slow cooling. Consequently, the alloys in the usual bearing range of 10-15% antimony, A.S.T.M. alloys 11 and 12, either will be predominantly eutectic or else contain a small amount of excess antimony-rich primary solid solution, as illustrated in Fig. 527*c*. The structure of an entire binary series of this type, in which partial solid solubility exists, already has been discussed previously in Chap. VIII and need not be repeated here. *Street's No. 4* is a commercial alloy of this type.

If as little as 2% tin is added, A.S.T.M. alloy 10, the properties will be equivalent to the low-tin group of lead-base bearings, but without this their ultimate strengths generally will run between about 13,000 psi at room temperature and 5000 psi at 212 F (100 C) with accompanying Brinell hardnesses (10 mm-500 kg) of 14-17 or 6-9, respectively.

The commercial alloys *Glacier Anti-Friction*, *Hoyts CB* and *Eagle B*, *Hewitts Bearing*, *Grant*, and *Bearite* are of the general type containing 2% tin or less and sometimes some arsenic in addition.

#### LEAD-ALKALI AND LEAD-ALKALINE EARTH ALLOYS

The earliest alloy of this group was the patented *Frery metal* which contained 0.10-1.0% calcium, 0.20-2.0% barium, with about 0.25% of mercury and tin, and smaller amounts of copper. Two alloys of this class are in fairly common use although the original alloy has been discontinued almost entirely.

*Bahnmetall*, a German alloy containing 98.63% lead, 0.03-0.05% lithium, 0.68-0.76% calcium, 0.62-0.72% sodium, 0.02-0.04% potassium, and less

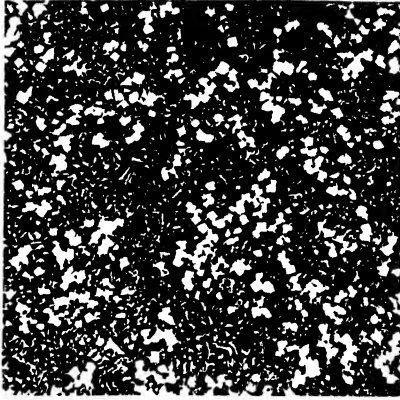
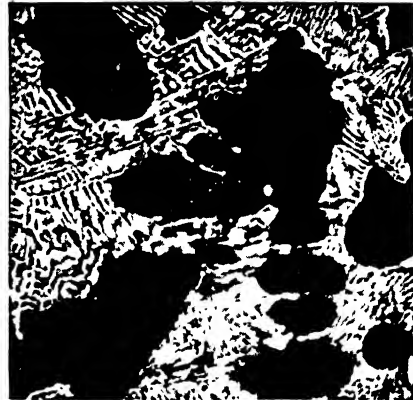
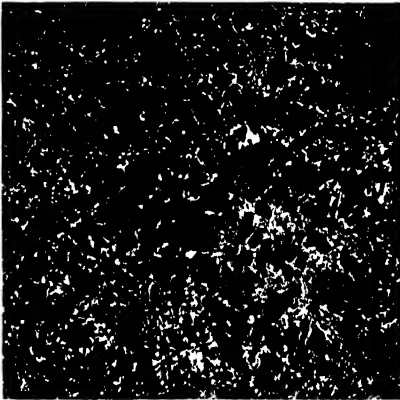
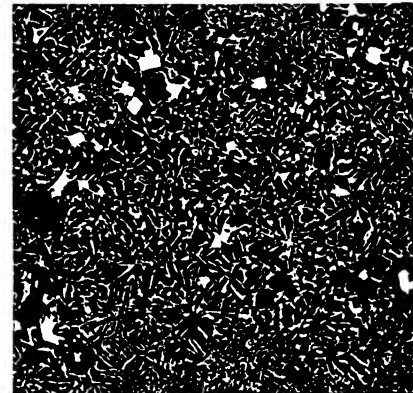
*a**b**b**c*

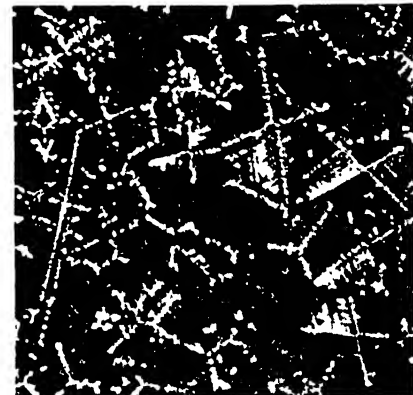
FIGURE 527. Metallographic structures of lead-base babbitts.

*a.* (Top left) High-tin type, S.A.E. No. 14, containing approximately 74% Pb - 10% Sn - 15% Sb - 0.5% As - 0.25% Cu. Etched with nital.  $\times 100$ . (Photomicrograph courtesy The Cleveland Graphite Bronze Company.)

*b.* (Top right and middle left) Low-tin type, S.A.E. No. 13, containing approximately 85% Pb - 5% Sn - 10% Sb. Etched with nital. Chill cast.  $\times 100$ , left;  $\times 500$ , right. (Photomicrograph by L. Litchfield.)

*c.* (Middle right) Lead-antimony type, containing approximately 87% Pb - 13% Sb. Etched with nital.  $\times 100$ .

*d.* (Lower right) Lead-alkali or -alkaline earth type, containing small amounts of calcium, tin, and magnesium. Etched with nital.  $\times 100$ . (Photomicrograph courtesy National Lead Company, Research Laboratory.)

*d*

than 0.20% aluminum, is a typical example. *Satco*, the American alloy, contains 97.5% lead, with the balance calcium, tin, and magnesium. A third alloy that is used to some extent in Europe and more closely resembles the original analysis is *Lurgimetall*, which contains 96.5% Pb–2.8% Ba–0.40% Ca–0.30% Na. The English *Calloys* are also of this general type.

*Satco* is apt to be somewhat weaker and softer than the foreign alloys which will have a compressive strength of 25,000–30,000 psi, with a Brinell hardness (10 mm–500 kg) of 30 at room temperature and 20–25 at 212 F (100 C). These alloys, as a class, generally retain their properties better at elevated temperatures than the competitive light-duty bearing metals.

The important structural constituents are the intermetallic compounds, such as  $Pb_3Ca$ , and  $PbMg_2$ , which are present in the alloy because of the extremely small solid solubility of both calcium and magnesium in lead. This same low solubility accounts, to a great extent, for the retention of properties at elevated temperatures because of the precipitation-hardening characteristics which accompany it. Some of these precipitated compounds can be seen in the typical microsection shown in Fig. 527*d*.

#### IRON POWDER BEARINGS

Much attention is being devoted to the development of iron-base bearings by means of powder metallurgical methods. An 88:10:2 iron-copper-graphite alloy has been used, the graphite combining with the iron to some extent during sintering to give a porous steel. Improvements in the production of a lower cost powdered iron undoubtedly will accelerate the use of this type of product. Several methods of achieving this result are now in process of development although, basically, it is largely a question of creating a large enough demand. In the early work, Swedish sponge iron was used in most cases.

#### *For Further Study Refer to*

1. *Bearing Metals and Bearings*, by W. M. Corse: Reinhold Publishing Corporation, New York, 1930.
2. *Bearing Metal Data*: Federal-Mogul Corp., Detroit, Mich.
3. *Metals Handbook*: American Society for Metals, Cleveland, Ohio, 1939 (usually published triennially). A new edition will appear in 1948.
4. *Bearing Metals and Alloys*, by H. N. Bassett: Longman's, Green and Company, New York, 1937.
5. *The Bearing Bronzes*: Copper Development Assoc., London.

6. *Lead Bronze Bearings*: Copper Development Assoc., London, 1939.
7. *Handbook for Engineers and Machine Designers*, 3d ed.: Lumen Bearing Company, Buffalo, N. Y., 1942.
8. *Powder Metallurgy*, edited by John Wulff: American Society for Metals, Cleveland, Ohio, 1942.
9. *Materials and Methods* (formerly *Metals and Alloys*): Reinhold Publishing Corporation, New York (published monthly).
10. *Metal Progress*: American Society for Metals, Cleveland, Ohio (published monthly).
11. *S.A.E. Journal*: Society of Automotive Engineers, Inc., New York.

## Alloys Used Because of Their Special Physical Properties

**T**HERE ARE MANY OUTSTANDING DEVELOPMENTS IN ENGINEERING which have been made possible only by the use of metals and alloys having very specialized properties. However, since these properties are more often physical than mechanical and since the amounts of metal involved are generally small, the materials themselves frequently are overlooked. This has resulted often in limited fields of application for materials which might be used much more widely were their characteristics more generally known.

The real significance of these materials becomes clearer when it is realized that they have made possible the perfection of modern radio, television, telegraph and telephone equipment, as well as many electrical and magnetic devices and gadgets that make everyday life more pleasant. Furthermore, it is these materials which have enabled the development of the standard instruments and gauges which have been themselves the basic factor in the growth of American mass-production methods.

Some of the more important of these materials which will be discussed briefly include:

1. *Electrical conductivity* alloys
2. *Electrical resistance* alloys
3. *Thermoelectric* materials
4. Alloys with *controllable thermal expansion* characteristics
5. Alloys with *specific melting* ranges
6. *Magnetic* alloys

Applications of the nature of those mentioned here seldom can be filled satisfactorily by other than metals or alloys, although, in the relatively few instances where this has been possible, mention will be made of some of the competitive materials. Many of the alloys and materials either are proprietary or their production is limited to a comparatively few concerns. The advice of the manufacturer should be sought when new applications are being considered.

## *Electrical Conductivity Alloys*

### ALLOYS WITH HIGH ELECTRICAL CONDUCTIVITY

The pure metals have higher electrical conductivities than any alloys, and *copper* and *aluminum* in particular are used extensively because of this fact. *Silver*, which has the highest conductivity of any of the metals, on a volume basis, has found little commercial application because of its comparatively high cost. However, in case of an industrial shortage of copper, as recently occurred under emergency conditions, the substitution of silver for copper bus bars in large power substations on a loan basis from the government, in high-potential transmission lines, and in similar concentrated installations released appreciable quantities of copper for industrial use.

#### HIGH-CONDUCTIVITY COPPER

There are three principal types of high-conductivity *copper* made commercially today: (a) *tough-pitch* copper; (b) *deoxidized* copper; and (c) *oxygen-free* copper.

A fourth alloy, *arsenical* copper, is not used widely in this country for conductivity purposes, and, therefore, has been included in Chap. XIV among the corrosion-resisting rather than the conductivity coppers.

All factors which affect the regularity of the space lattice tend to decrease the electrical conductivity. Thus, the purity of conductivity copper must be controlled carefully, because even small amounts of most of the common impurities, with the exception of lead, oxygen, and silver, affect the conductivity adversely as illustrated in Fig. 528.<sup>1</sup> Cold-work has a similar effect, however somewhat less marked, usually resulting in a maximum decrease in the conductivity of about 3%.<sup>2</sup>

#### TOUGH-PITCH COPPER

Tough-pitch copper usually averages about 0.04% oxygen (as  $\text{Cu}_2\text{O}$ ) and may contain, if it is also a "lake" copper, as much as 0.1% silver (10 oz silver per ton is equivalent to 0.034%). In these amounts, neither of these elements will reduce the electrical conductivity appreciably, and values of 101% of the International Annealed Copper Standard (I.A.C.S.) usually are secured. The presence of silver, as shown in Fig. 68, will increase the

<sup>1</sup> See also S. L. Archbutt and W. E. Prytherch, *British Non-Ferrous Metals Research Assoc. Monograph No. 4*, London, 1937.

<sup>2</sup> See D. K. Crampton, H. L. Burghoff, and J. T. Stacy, *Trans. A.I.M.E.*, **143**, 1941, 228-245.



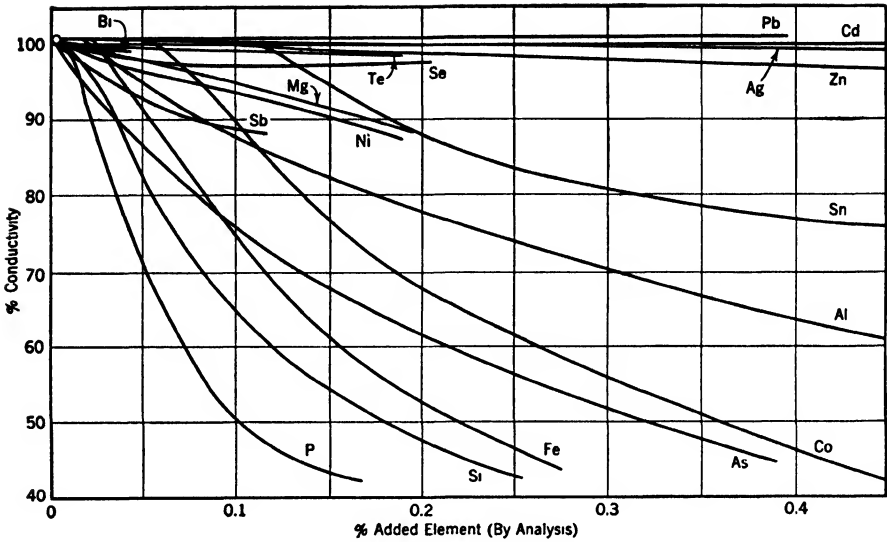


FIGURE 528. Effects of small amounts of various elements, when present alone, on the electrical conductivity of copper. (From unpublished data of S. Skowronski, International Smelting and Refining Company.)

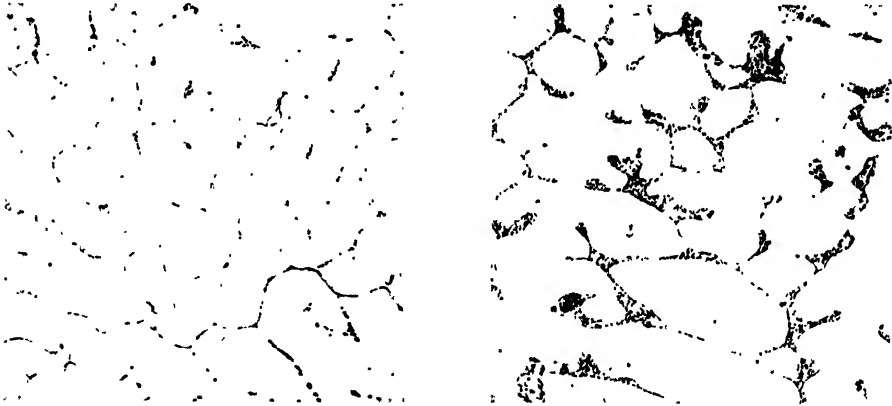


FIGURE 529. Metallographic structures of two tough-pitch coppers containing 0.025% (*left*) and 0.075% (*right*) oxygen (as  $Cu_2O$ ), as cast. Etched with  $NH_4OH+H_2O_2$ .  $\times 100$ . (Photomicrographs by M. Brezin.)

recrystallization temperature from about 400 F (200 C) for pure copper to as high as 750 F (400 C), and thus is beneficial for other reasons.

Any silver will be in solid solution, but oxygen will be found in the microstructure either as small globules of cuprous oxide or as the copper-cuprous oxide eutectic. This is illustrated in Figs. 529 and 530 in typical photomicrographs. The mechanical properties of tough pitch copper (Fig. 531), tend to fall somewhat below those of the oxygen-free types. Although



FIGURE 530. Metallographic structures of hot-rolled (left),  $\times 500$ , and cold-worked and annealed (right),  $\times 200$ , tough-pitch copper showing distribution of oxide. Etched with  $\text{NH}_4\text{OH} + \text{H}_2\text{O}_2$ . (Photomicrographs courtesy (left) Research Laboratory, General Electric Company, and (right) Research Laboratory, Westinghouse Electric Corp.)

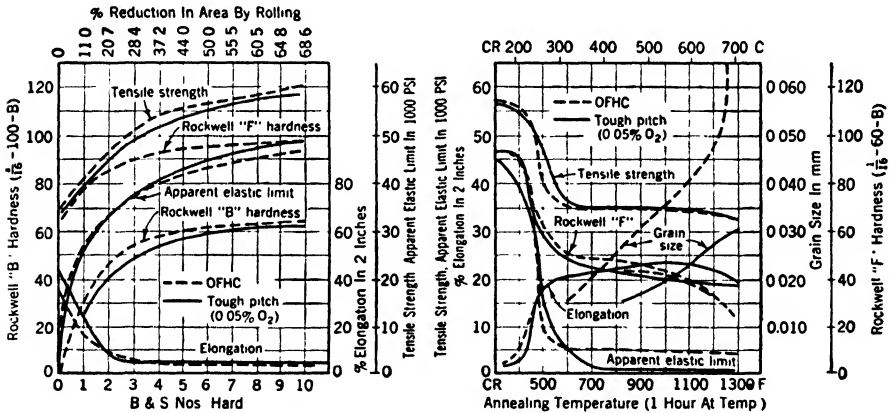


FIGURE 531. Comparison between the mechanical properties of tough-pitch and O.F.H.C. coppers. Left, during cold-rolling to various reductions. Right, during annealing. (From *Copper and Copper Base Alloys* by R. A. Wilkins and E. S. Bunn: McGraw-Hill Book Company, Inc., New York.)

data are not shown, the reduction in area, in particular, is decreased by the presence of copper oxide in the cross section.

In addition to its uses for bus bars, conductivity wire, and electrical conductors in general, tough-pitch copper also has been used for ball floats, down spouts and gutters, flashings, gaskets, projectile rotating bands, radiators, rivets, roofing, screen cloth and wire, applications discussed further in Chaps. XIII and XIV.

Bare copper electrical conductors are covered by A.S.T.M. Standards B1 (Hard-Drawn Wire), B2 (Medium Hard-Drawn Wire), B3 (Soft Wire), B8

(Cable, Concentric-Lay-Stranded), B47 (Trolley Wire), B49 (Hot Rolled Rod), B33 (Tinned Soft Wire), and B48 (Soft Rectangular or Square Wire), and Tentative Standards B152-T (Sheet, Strip, and Plate) and B172-T, B173-T, and B174-T (Cable, Rope-Lay- and Bunch-Stranded). Standards D353, and D469, and Tentative Standards D27-T, and D574-T apply to insulated conductors.

The most serious difficulty encountered with any of the oxygen-bearing coppers is their tendency to embrittle at temperatures above about 750 F (400 C) when exposed to reducing gases, especially those containing hydrogen,<sup>3</sup> or to conditions involving moisture or oil plus heat plus iron. For any application in which such conditions exist, they definitely are not recommended. The nature of and explanation for this have already been discussed in Chap. XIII and illustrated in Fig. 391.

#### HIGH-CONDUCTIVITY DEOXIDIZED COPPER

By using various deoxidizing agents, such as phosphorus, calcium, or lithium, in a very carefully controlled manner, the oxygen content of copper can be reduced to a very low value without any appreciable amount of residual deoxidizer remaining in the metal. For example, phosphorus can be kept well below 0.01% without difficulty, thus enabling high-conductivity specifications to be met. The microstructure of these alloys will be identical with those of pure copper, as shown previously in Fig. 163, although sometimes they are not so free of inclusions as some of the other grades. However, 101% conductivities still can be secured with very little change in the mechanical properties.

In addition to their electrical applications these coppers also are used for condenser, dairy and distiller tubes, gas and gasoline lines, heater units, oil-burner tubes, and for refrigerator, oil, steam, and water tubing as mentioned previously. For seamless tubing of various sorts, A.S.T.M. Standards B68 and B88 and Tentative Standard B75-T apply, and the electrical applications largely will fall under the Standards given above.

#### LOW-CONDUCTIVITY DEOXIDIZED COPPER

If a larger amount of phosphorus is used as a deoxidizer, so that the residual is about 0.02%, the conductivity will be lowered somewhat to about 80–90% I.A.C.S., but with no commensurate increase in strength and no noticeable change in microstructure. This material still falls within the

<sup>3</sup> See, for example, L. L. Wyman, *Trans. A.I.M.E.*, **104**, 1933, 141; *ibid.*, **111**, 1934, 205.

limits of A.S.T.M. Standards B68, B88, and B75-T for use as tubing, but its electrical applications are limited because of its lower conductivity. This is the metal which makes up a large proportion of the copper water tubing used industrially to resist mild corrosion, as discussed in Chap. XIV.

#### OXYGEN-FREE HIGH-CONDUCTIVITY COPPER

By melting and casting very pure copper under conditions which prevent absorption of oxygen, by continuous casting in rod form by any of several similar processes, or by hot-extruding compressed copper cathodes into rod

without melting,<sup>4</sup> a very pure form of copper having an extremely clean structure and a high conductivity can be produced. The conductivity of the trade-marked brand, *O.F.H.C.*, may be as high as 102% I.A.C.S., and there is no tendency toward hydrogen embrittlement at elevated temperatures because of the absence of oxides in the microstructure as illustrated in Fig. 532. This material, too, is used for both electrical purposes and tubing under the various A.S.T.M. Standards given above. However, because of its high purity it has been a premium grade metal, and many consumers have been unwilling to pay the slightly higher price since the development of the less expensive high-conductivity deoxidized coppers.

The general class of oxygen-free high-conductivity coppers probably includes the purest of the engineering metals in direct commercial use today.

#### ALUMINUM CONDUCTORS

When measured by the customary method of equal cross-sectional areas, pure aluminum has 64% the (volume) conductivity of copper. However, since it has a density only one-third that of copper, an aluminum conductor would have about one-third the weight of a copper conductor of equal volume. For conductors of equal length and weight, therefore, aluminum would have more than 212% the (mass) conductivity of copper, and a con-

<sup>4</sup> This process is described by John Tyssowski in Chap. 30 of Ref. 8 at the end of this chapter.



FIGURE 532. Metallographic structure of O.F.H.C. copper. Etched with  $\text{NH}_4\text{OH} + \text{H}_2\text{O}_2$ .  $\times 200$ . (Photomicrograph by L. Litchfield.) The dark spots are etching pits resulting from the long time required to etch this relatively pure material.

siderably greater strength, even though the mechanical properties of annealed aluminum are appreciably lower than those of annealed copper. In this size, however, they might be somewhat more expensive so their utility at any particular time will depend upon an economic balance between the cost of the two metals and the conductivity and strength properties required. At the present time indications are that any advantage in the immediate future will favor aluminum.

Some comparison between the mechanical properties can be made from the data in Table XLVI.

TABLE XLVI COMPARATIVE STRENGTH PROPERTIES OF ALUMINUM AND COPPER

	TENSILE STRENGTH, PSI	ELON- GATION, % IN 2 IN.	REDUC- TION IN AREA, %	BRINELL HARDNESS	PERCENTAGE LOAD- BEARING CAPACITY FOR EQUAL AREA	FOR EQUAL LENGTH AND WEIGHT
99.4% Aluminum	13,000	45	80	22*	40	120
99.97% Aluminum	8,500	60	95	16*	26	78
Copper	30,000– 35,000	40–45		40†	100	100

\*  $\frac{1}{8}$  in.—59 kg      † 10 mm—500 kg

Commercial aluminum conductors generally are made from aluminum of about 99.5% purity, hard drawn, a treatment which nearly doubles the tensile strength over the values given above, and with a conductivity of not less than 61% I.A.C.S. The manufacture of cable and bus bar for the transmission of electrical power is one of the large uses of this composition.

The addition of any elements in solid solution to harden and strengthen the metal will result in a marked decrease in conductivity. For this reason the various aluminum alloys generally are unsuitable for electrical purposes although in Europe an alloy of 98.8% Al–0.4% Mg–0.5% Si–0.3% Fe, known as *Aldrey*, has been used successfully for overhead transmission lines.

To overcome the difficulties arising from the comparatively low strength of aluminum cables having the same conductivity as copper, the commonest method has been to use a steel wire in the center of a stranded conductor. The steel materially increases the load-carrying capacity of the aluminum

without affecting its conductivity. Other methods, taking advantage of the principles of engineering design, such as built-up sections and special shapes, also have been used to some extent to increase the effective stiffness.<sup>5</sup>

#### FREE-MACHINING HIGH-CONDUCTIVITY COPPER

Pure copper is so tough that it is extremely difficult to machine even in the hard-drawn form. However, for many applications in electrical machinery, forgings and screw-machine parts are required which will have a high conductivity and at least fair machinability.

The addition of lead, the element usually added to improve the machinability of copper-base alloys, is undesirable because it tends to make the metal hot-short. However, in spite of this difficulty, free-machining high-conductivity coppers containing 1% lead, such as *946 alloy*, for example, are made commercially. They have a conductivity of 99% and a machinability about 80% that of free-machining brass, with about the same tensile strength and somewhat lower ductility than the nonleaded varieties. Their microstructure, as illustrated in Fig. 533*a*, will be similar to those of the nonleaded varieties except for the appearance of small areas of insoluble lead scattered throughout the cross section.

A marked improvement in machinability can be secured, in a manner similar to that produced by lead, by the addition of up to 1% sulfur, 1.5% selenium, or 2.5% tellurium.<sup>6</sup> All of these elements are practically insoluble in copper, and appear as small *chip breakers*, in a manner similar to lead, in the microstructures shown in Figs. 403 and 533. However, these alloys are not hot-short, and may be worked equally well either hot or cold. A 0.5% tellurium alloy, for example, will have a machinability rating of about 90%, with a conductivity of 85% when deoxidized normally with phosphorus or as high as 98% when high conductivity is specified. These materials also have been discussed in Chap. XIII.

#### CONDUCTIVITY BRONZES

For many electrical applications, such as line wire, messenger wire, and trolley wire in railroad electrification, comparatively heavy wind, snow, and ice loads must be borne without stretching. In these applications the strength requirements are so important that a compromise must be made,

<sup>5</sup> This subject is discussed in *Overhead Transmission Lines*, British Aluminium Company, Ltd., London, 1934.

<sup>6</sup> See C. S. Smith, *Trans. A.I.M.E.*, **128**, 1938, 325-334; and H. L. Burghoff and D. L. Lawson, *Trans. A.I.M.E.*, **128**, 1938, 315-324.

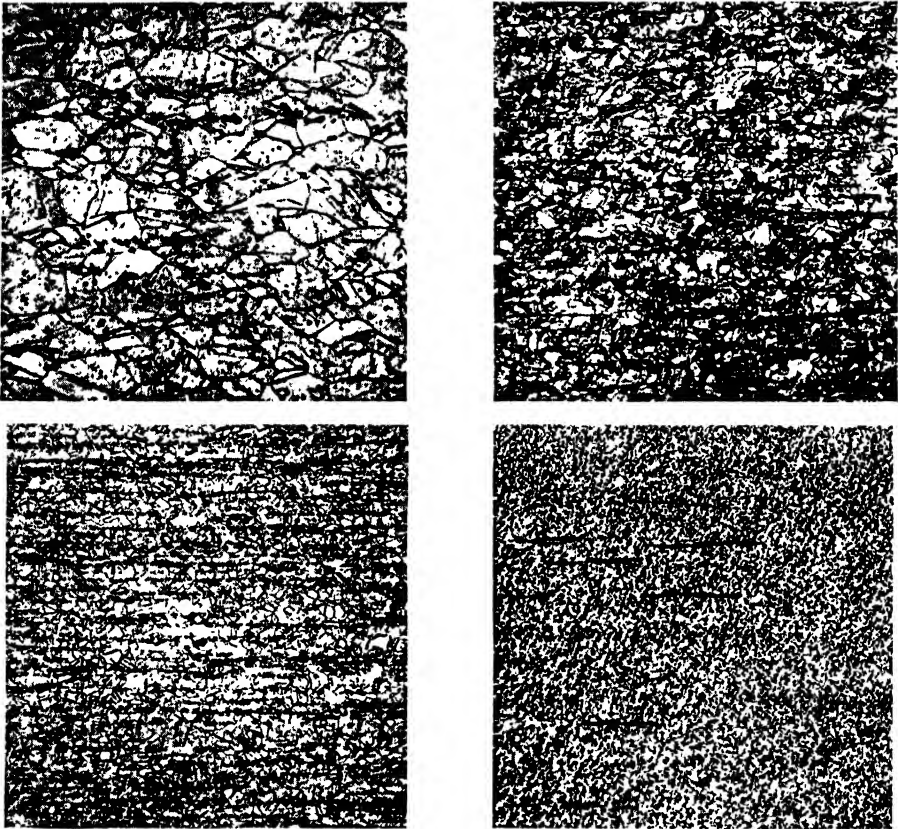


FIGURE 533. Metallographic structures of longitudinal sections of some commercial free-machining high-conductivity copper-base rod alloys in the annealed condition. Etched with  $\text{NH}_4\text{OH} + \text{H}_2\text{O}_2$ .  $\times 75$ .

a. (Upper left) Leaded copper (0.94% Pb–0.03% P – rem. Cu).

b. (Upper right) Tellurium copper (1.05% Te – rem. Cu).

c. (Lower left) Selenium copper (0.90% Se – rem. Cu).

d. (Lower right) Sulfur copper (0.78% S – rem. Cu).

(Photomicrographs courtesy Technical Department, The American Brass Company.) Structure of the *b* alloy in the hard-drawn condition is illustrated in Fig. 403.

and either a steel or hollow-cored conductor or an alloy with higher strength and a lower conductivity used in order to satisfy them. Many of these stronger alloys, known generally as conductivity bronzes, are covered by A.S.T.M. Standard B105, the grade of the alloy corresponding to its minimum conductivity, but Standards B9, B47, and B116 also are relevant. Commercially they are sold under the trade names *Hitenso* and *Phonoelectric Bronze* as well as *Conductivity Bronze*.

For these purposes cadmium and tin are the principal alloying elements

used because they produce the maximum increase in strength with the minimum decrease in conductivity. In all cases the alloying elements will be in solid solution so the microstructures will be nearly identical with those of pure copper. However, the properties will vary markedly, as indicated in Table XLVII for the common grades in A.S.T.M. Standard B105.

TABLE XLVII PROPERTIES TYPICAL OF THE CONDUCTIVITY BRONZES

MINIMUM CONDUCTIVITY GRADE % I.A.C.S.	USUAL COMPOSITION			TENSILE STRENGTH, PSI	
	% CU	% CD	% SN	DRAWN 10 B. & S. NO.	DRAWN 4 B. & S. NO.
85	99.2	0.8	—	79,000	61,000
80	90.0	1.0	—	83,000	65,000
65	99.5	—	0.5	75,000	61,000
55	96.7	0.8	0.5	90,000	72,000
40	98.5	—	1.5	86,000	69,000
30	98.2	—	1.8	100,000	71,000

For applications involving combinations of high strength and intermediate conductivity, an age-hardening alloy, known both as *No. 58 Alloy* and as *Phosnic Bronze*, has been developed containing, nominally, 1.10% Ni–0.22% P–rem. Cu.<sup>7</sup> A free-machining grade containing about 0.5% tellurium also is made. When this alloy is quenched from about 1475 F (800 C), and then aged properly at temperatures in the range 600–750 F (320–400 C), tensile strengths of 70,000 psi can be developed, with a yield strength (0.5% elongation) of 47,000 psi, an elongation of 18% in 2 in., and a Rockwell hardness of B76. In this condition, the alloy will have a conductivity of about 65%, and a machinability rating of about 60% that of free-turning brass. The free-machining grade is even better in this latter respect.

### *Electrical Resistance Alloys*

The perfection of electrical resistance alloys which could be used at temperatures up to about 1800 F (1000 C) for long periods of time was of great industrial importance, because it made possible the electrification of many phases of heat-treatment. These materials also have enabled the development of many electrical devices such as flatirons, toasters, electric stoves,

<sup>7</sup> See D. K. Crampton, H. L. Burghoff, and J. T. Stacy, *Trans. A.I.M.E.*, 137, 1940, 354–370.



heating pads, and similar articles which are of convenience around the home. Nearly all the resistance alloys of industrial importance today contain iron, nickel, or chromium as major elements and copper, aluminum, cobalt, or manganese as minor elements. They cover a wide range of specific resistances, from 60–1000 ohms per cir mil-ft (10–170 microhm-cm). However, only two types of alloys are used in the majority of the commercial applications, those of nickel and chromium and those of iron, nickel, and chromium.

#### LIFE TEST

Resistance alloys, usually in the form of wire or ribbon, customarily are tested by the standard accelerated test described in A.S.T.M. Standard B76 in order to determine their probable life in service. This involves mounting the specimen vertically on a shielded panel and heating it intermittently by an electric current under constant voltage conditions with a cycle 2 min on and 2 min off. The total elapsed time from the end of the first 10 min aging period to the burnout is considered to be the *total life* of the specimen. The elapsed time to increase the resistance 10% is considered as its *average useful life*.

The development and use of this standard test has resulted, over a relatively short span of years, in an improvement of several hundred per cent in the life of these alloys.

#### COPPER-NICKEL RESISTANCE ALLOYS

As with most solid solutions, the alloys of copper and nickel (cf. Fig. 188c) have much higher electrical resistivities than either of their components. Several copper-nickel resistance alloys are made industrially for applications at moderate temperatures, or for “cold resistance” purposes, such as certain electrical resistances and rheostats, speed regulators, and d-c starters, where their particular range of resistances and other properties are valuable. Some of the more common alloys are shown in Table XLVIII.

About 1% manganese usually will be added to these compositions to facilitate casting and working, and, in addition, small amounts of iron or carbon will be present as impurities. All of these elements usually will be found in solid solution, so the microstructures will resemble those of nickel or copper.

Tensile strengths of the order of 50,000 psi, annealed, or 100,000 psi, cold-worked, can be secured readily, accompanied by fair workabilities.

TABLE XLVIII COMMERCIALY IMPORTANT COPPER-NICKEL RESISTANCE ALLOYS

	% NI	% CU	RESISTIVITY AT 68 F (20 C)	
			OHMS PER CIR MIL-FT	MICROHM-CM
<i>Lohm</i>	7-7.5	Rem.	60	10
<i>Midohm</i>	22-23	Rem.	180	30
<i>Constantan*</i>	44-46	Rem.	294	49

\* This composition also is sold under the names *Advance*, *Copel*, and *Cupron*. The alloy *Constantan*, which also is used in thermocouples and for heating elements that do not operate over 800 F (425 C), has practically a constant resistance in the range 68-900 F (20-480 C).

## MANGANIN

The alloy *Manganin* with a nominal composition of 4% Ni-12% Mn-84% Cu, has a specific resistance of 290 ohms per cir mil-ft (49 microhm-cm) in the form of wire. In addition, its thermal electromotive force against copper<sup>8</sup> is so small that any parasitic electromotive forces would be negligible, and its highest resistance is at 77 F (25 C), decreasing at higher or lower temperatures in the usual room-temperature range. Because of these characteristics and the alloy's stability, it is used widely in all sorts of precision apparatus for electrical measurements, such as bridges, potentiometers, and resistance boxes. In some cases, the strains produced by winding resistances may be harmful but they can be removed by heating the completed coils at 250 F (120 C) for 24 hr.

By decreasing the manganese content somewhat without changing the nickel content, the maximum resistance can be secured at 112 F (45 C) instead of 77 F (25 C) although the resistivity is lowered thereby to 180 ohms per cir mil-ft (30 microhm-cm). This modification is used chiefly as a shunt material for d-c meters. In such applications, it will be heated somewhat because of the passage of some current through the shunt. Hence, the higher temperature for maximum resistance is desirable, especially since it is stable over a fairly wide temperature range.

## NICKEL-CHROMIUM RESISTANCE ALLOYS

The simplest and best combination of metals for applications requiring electrical resistance is the alloy containing, nominally, 80% Ni-20% Cr

<sup>8</sup> See A.S.T.M. Standard B77.

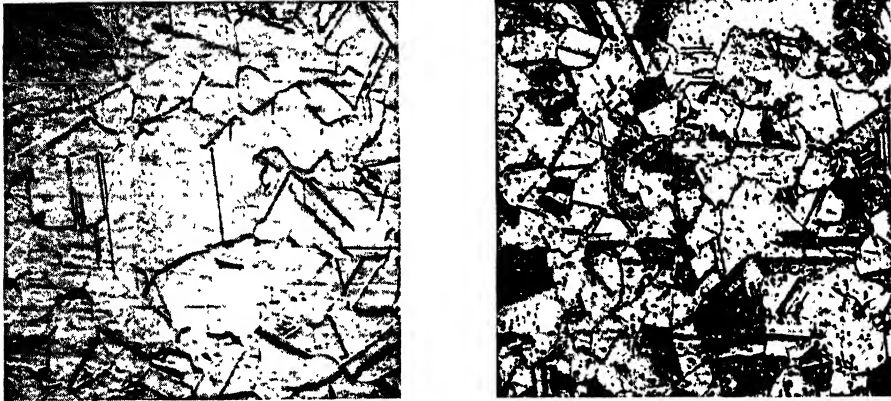


FIGURE 534. Photomicrographs illustrating the effect of small amount of carbon on the metallographic structures of an electrical resistance alloy of the 80% Ni - 20% Cr type. Etched with nitric and acetic acids.  $\times 200$ . (Courtesy Driver-Harris Company.)  
*a.* (Left) 0.02% carbon, showing essentially no carbides.  
*b.* (Right) 0.06% carbon, carbides precipitated showing that the solubility limit has been exceeded.

which is sold commercially under the names *Chromel A*, *Tophet A*, and *Nichrome V*, and is covered by A.S.T.M. Standard B82. This alloy is a nickel-rich solid solution at all temperatures and has a microstructure characterized by the annealing twins typical of nickel-base solid solution alloys (Fig. 534*a*).

Carbon is sometimes present in the alloy or is absorbed when it is used in carbon-bearing atmospheres. In amounts less than 0.04–0.05% it is soluble, but in greater amounts it will appear in the microstructure as spheroidized chromium carbides (Fig. 534*b*). Manganese in amounts up to 2% frequently is added to assist workability and deoxidation, and silicon in amounts of 0.1% sometimes is used for the same reason.

The electrical resistivity of this alloy is about 650 ohms per cir mil-ft (108 microhm-cm). However, the change in resistance with temperature (Fig. 535) is not linear, and hence a temperature coefficient cannot be applied. The reason for the dip at about 1000–1250 F (540–680 C) is not entirely clear, but it probably results from an atomic rearrangement in the alloy. For determining the hot-resistance for design purposes, it is recommended by the manufacturers that actual tests be run. The electrical resistance of these alloys at 68 F (20 C) is dependent on the heat-treatment. Annealing increases the resistance, exactly the opposite of the usual behavior of metals and alloys. This increase may vary from 2–7% depending on the amount of previous cold-work and the time and temperature of the anneal. The resistance also is increased if the annealed and quenched material has been reheated to 1830 F (1000 C) and cooled slowly.

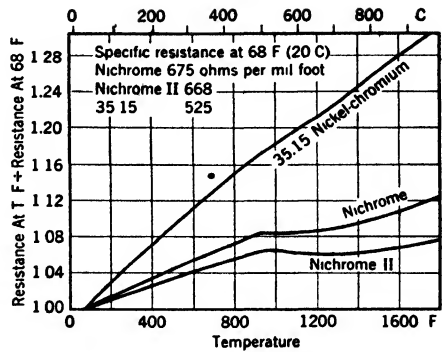
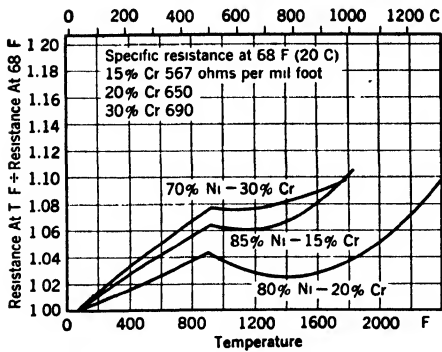


FIGURE 535. (Left) Ratio of electrical resistance at various temperatures to resistance at 68 F (20 C) for three nickel-chromium alloys. (After M. A. Hunter in Ref. 1 at the end of this chapter.)

FIGURE 536. (Right) Ratio of electrical resistance at various temperatures to resistance at 68 F (20 C) for three nickel-iron-chromium alloys.

ALLOY	% NI	% FE	% CR	% MN
Nichrome	61.20	24.88	12.05	1.44
Nichrome II	69.35	10.53	17.95	1.58
35:15	35	Rem.	15	2

(After M. A. Hunter in Ref. 1 at the end of this chapter.)

The mechanical properties of the alloy at room temperature are good, averaging 95,000 psi tensile strength, with a yield point of 50,000 psi, an elongation of 25–35% in 10 in., a reduction in area of 55%, and a Rockwell hardness of B85–90 in the annealed condition, and B100–105 in the hard-drawn condition. By cold-working, the strength can be increased to 175,000 psi although this, of course, will be lost when the alloy is heated. At elevated temperatures, these values decrease appreciably once 800 F (425 C) is exceeded. With materials such as this, tensile test data have little real significance, and the recommended safe loading, which depends on the creep strength, is more important.

The alloy resists most furnace gases satisfactorily with the exception of those of a reducing sulfur-bearing nature. Nickel-chromium alloys, containing up to 30% chromium, can be made with increased oxidation resistance, but many manufacturing difficulties are encountered so the 20% alloy is used more commonly.

IRON-NICKEL-CHROMIUM RESISTANCE ALLOYS

The alloys containing 60–62% nickel, 12–15% chromium, 0–2% manganese, with the remainder essentially iron, are covered by A.S.T.M. Stand-

ard B83. They have a higher specific resistance, 675 ohms per cir mil-ft (112 microhm-cm) than the nickel-chromium alloys, and the highest electrical resistivity of any of the nickel-chromium-iron alloys. They also show the same anomalies in temperature coefficient as the nickel-chromium alloys but to a lesser extent (Fig. 536), and their resistance at 68 F (20 C) is similarly affected by heat-treatment after quenching. Materials of this type are sold under the trade names *Chromel C*, *Tophet C* and *Nichrome*.

The mechanical properties:

---

Tensile strength, psi (depending upon the treatment)	95,000-175,000
Elongation, % in 2 in.	35-0.5
Rockwell hardness	B83-C24

---

are somewhat better than those of the nickel-chromium alloys. The oxidation resistance is satisfactory up to 1650 F (900 C), because of the tightly adherent coating of oxide formed on the surface. However, it is not recommended for use above 1700 F (930 C), or where silicates could attack the oxide coating at elevated temperatures. In these respects, therefore, it has somewhat less utility than the straight nickel-chromium alloys.

In addition to elements in heating devices, the iron-nickel-chromium alloy also is used for sheet carburizing-, annealing- and molten salt containers, high-resistance rheostats, potentiometers, and dipping baskets and racks for acid pickling, cyanide hardening, and enameling where resistance to corrosion is valuable. This was discussed in Chap. XV.

The metallographic structure of this alloy (Fig. 437) is also that of a typical nickel-base solid solution, similar to the nickel-chromium alloys. As before, any carbon in excess of that soluble in the alloy will appear as spheroidized chromium or iron-chromium carbides.

#### MOLYBDENUM AND TUNGSTEN HEATING UNITS

For maintaining temperatures up to 2550 F (1400 C) molybdenum or tungsten resistors can be used.<sup>9</sup> However, these metals tend to sublime as oxides in atmospheres containing oxygen or water vapor and become embrittled if they are carburized. Hence they must be used in a protective atmosphere such as hydrogen although special cracked gases may be used for some applications. This complicates their commercial use considerably.

For operation in air a molybdenum heating element recently has been

<sup>9</sup> See, P. Schwarzkopf, *Metals and Alloys*, 13, 1941, 45-49; W. Kroll, *Trans. Electrochem. Soc.*, 79, 1941, 199-212.

developed that is protected by a special refractory coating in which beryllium oxide is used as the layer next to the pure molybdenum.

#### IRON-CHROMIUM-ALUMINUM RESISTANCE ALLOYS

Several alloys have been developed comparatively recently which have such excellent electrical and oxidation-resistant characteristics that they can be used at temperatures appreciably higher than those safe for nickel-chromium alloys. However, because of excessive grain growth in use, they tend to become brittle in time. In addition, their strength is very low at elevated temperatures. Because of these two features their greatest usefulness has been for applications in the intermediate range between the higher temperatures better suited to silicon carbide and the lower temperatures where the nickel-chromium-iron alloys are more useful. Some of the more important of these alloys are given in Table XLIX.

TABLE XLIX COMMERCIALY IMPORTANT IRON-CHROMIUM-ALUMINUM RESISTANCE ALLOYS

	% FE	% CR	% AL	% CO	SPECIFIC RESISTANCE OHMS PER CIR MIL-FT	MICROHM- CM
<i>Ohmax</i>	Rem.	20	5-8.8	0-5	800	137
<i>Radiohm*</i>	Rem.	12-13	4-5	—	—	—
<i>Kanthal</i>	67	25	5	3	812-872	138-148
<i>Smith No. 10</i>	55	37.5	7.5	—	1,000	.170

\* This composition also is sold under the names *Fecraloy* and *Alcres*.

All of the alloys containing aluminum have an excellent resistance to oxidation at elevated temperatures because of the aluminum oxide film which forms on the surface, but they are somewhat difficult to fabricate under most conditions.

The electrical resistance of *Ohmax* is utilized in radio resistors requiring a high resistance in a minimum of space. This alloy also will have a comparatively high strength, 125,000-200,000 psi, depending upon the treatment it has been given.

The *Kanthal* alloys<sup>10</sup> are used chiefly in furnaces and electrical heating units, domestic and industrial. By varying the chromium, aluminum, and

<sup>10</sup> See also G. Nordstrom, *Metal Progress*, October 1935, p. 68.

cobalt contents, three grades are produced which have safe operating temperatures of 2100, 2375, and 2450 F (1150, 1300, and 1340 C) respectively. Even at the maximum operating temperature, their resistance is only 6% greater than at room temperature. When properly heat-treated the alloys will have tensile strengths at 70 F (20 C) of about 110,000 psi, with elongations of 14% in 10 in., and reductions in area of 64%. However, they lose this strength rapidly at elevated temperatures and must be supported properly in use. Above 2000 F (1100 C) they will elongate and fail under their own weight. Refractories used with them must be free from silica and iron oxide, or severe corrosion of the metal will result. The alloys are very brittle when improperly heat-treated and once a furnace wound with them has been heated and cooled, the wire cannot be cold-deformed further without breaking. However, when properly used, they will retain essentially a constant resistance throughout their life and give good service in a temperature range in which the nickel-chromium-iron alloys are rather undependable.

*Smith No. 10*<sup>11</sup> alloy is workable hot, but is comparatively brittle when cold. This increases fabrication difficulties considerably. It has a higher resistance than any of the other alloys, but is subject to the same problems of lack of strength at elevated temperatures, grain growth, and attack by refractories. The range of temperatures in which it is useful parallels those of the Kanthal alloys which have been on the market for a somewhat longer period of time.

#### SILICON CARBIDE HEATING ELEMENTS

Although not an alloy, silicon carbide (*carborundum*) resistance heating units, which are extremely important in the high-temperature field, have been developed in the form of rods. Using air-cooled contacts outside the heating zone, as illustrated in Fig. 537, it is possible to maintain temperatures in excess of 2700 F (1500 C) without difficulty by means of these units, provided the proper atmosphere is used. Commercially, they are sold under the name *Globar*.

Because the method of using them (Fig. 538) is different from that commonly employed with the resistance alloys as a group, it is recommended that specific information for any particular application be secured directly from the manufacturer. The rods are very brittle and have little strength, but will show practically no tendency to sag even at their maximum operating temperature.

<sup>11</sup> See also S. L. Hoyt, *Metal Progress*, July 1935, p. 38.

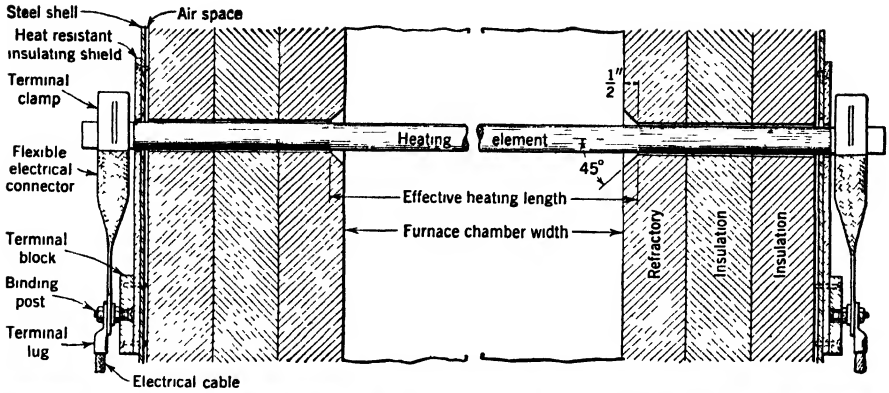


FIGURE 537a. (Upper) Section through furnace using silicon carbide (Globar) units as resistance heating elements.  
 b. (Lower) Photograph illustrating the appearance of a silicon carbide resistance heating unit in operation. (Courtesy Globar Division, The Carborundum Company.)



FIGURE 538. Commercial heat-treating furnace using Globar units. (Courtesy Globar Division, The Carborundum Company.)



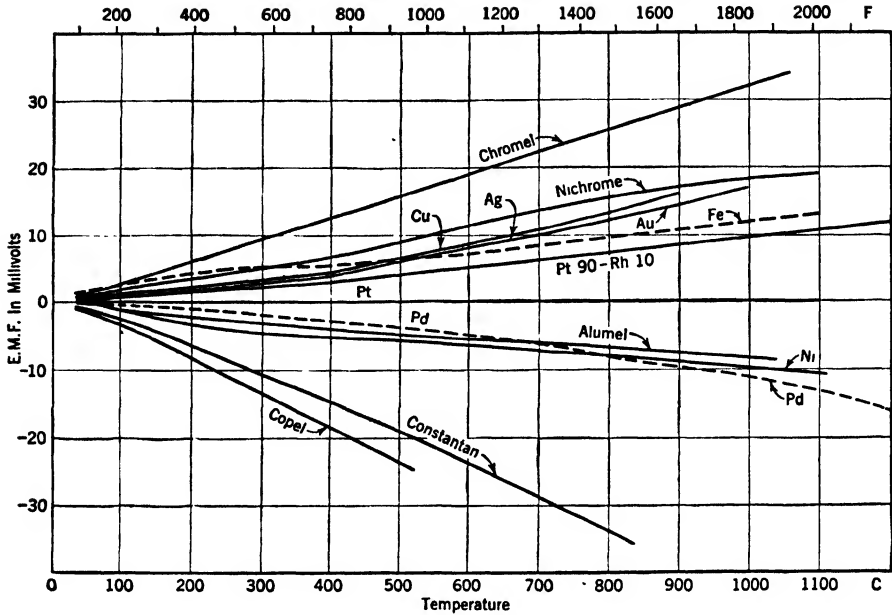


FIGURE 539. Thermoelectric potentials of different metals and alloys versus platinum. Cold Junction temperature 0 C (32 F). (From National Bureau of Standards Tech. Paper 170, 1921.)

### *Thermoelectric Materials*

#### ALLOYS FOR THERMOCOUPLES

If two dissimilar wires are joined electrically at the ends, as by welding for example, and the junction or weld is heated, a difference in potential will be produced between the two free ends. If these free ends are kept at a constant temperature, it will be found that this difference in potential is reproducible and depends upon the temperature of the hot junction. This is the simplest type of *thermocouple*.

The importance alloys used for thermocouples are selected on the basis of their change in electromotive force with temperature in comparison with some standard material such as pure platinum.<sup>12</sup> Typical examples of these data are illustrated in Fig. 539. Suitable alloys should have approximately a straightline relationship, ready reproducibility, constant calibration, reasonably large electromotive forces per degree temperature difference, and a reasonable cost.

The commonest thermocouple alloy combinations in use today with the maximum temperature limits recommended for continuous service are:

<sup>12</sup> See, for example, M. A. Hunter and A. Jones, *Temperature Measurement and Control in Science and Industry* (Amer. Inst. Phys.), 1941, 1227-1231.

1. *Chromel* (+) vs. *Alumel* (-) to 2200 F (1200 C)
2. *Iron* (+) vs. *Constantan* (-) to 1600 F (870 C)
3. *Copper* (+) vs. *Constantan* (-) to 1000 F (540 C)
4. *Platinum* alloyed with 10% *Rhodium* (+) vs. *Platinum* (-) to 2800 F (1540 C)
5. *Platinum* alloyed with 13% *Rhodium* (+) vs. *Platinum* (-) to 2800 F (1540 C)

The *Constantan* used for this purpose is the same 44–46% nickel, 56–54% copper composition that has been mentioned as a resistance alloy earlier in this chapter.

The first three of these combinations are known as *base metal* and the last two as *noble metal* thermocouples. The noble metal 'couples give much smaller electromotive forces than the base metal 'couples for a given temperature and hence require more accurate instruments for measuring their millivoltage. It is customary to assume a cold junction temperature of either 0 F or 32 F (0 C) and to compensate for variations. Practically, this latter temperature base can be secured quite readily by the use of properly prepared and agitated ice-water mixtures, whereas the advantage of the former base in working with degrees F is that a direct addition of the value for room temperature to the thermocouple reading gives the correct temperature.

The alloy *Chromel-P* has the composition 90% Ni–10% Cr and a resistivity of 425 ohms per cir mil-ft (72 microhm-cm). It was selected because it had the highest positive electromotive force against platinum of any nickel-chromium alloy, and an alloy of this general analysis was desired because of its oxidation resistance. This material also is sold, for use in thermocouples, under the trade name *Nichrome*.

The alloy *Alumel* has a nominal composition of 94% Ni–2% Al–3% Mn–1% Si, and a resistivity of 177 ohms per cir mil-ft (30 microhm-cm). It was developed to overcome difficulties encountered with pure nickel because of the Curie transformation at 680 F (360 C) and a tendency to embrittle when exposed to furnace gases. The *Chromel-Alumel* 'couple gives best results in an oxidizing atmosphere, and is not recommended for use under reducing conditions.

Recent developments in this field are a nickel vs. nickel-molybdenum 'couple, which appears to be very stable up to about 2200 F (1200 C) in reducing atmospheres of the cracked hydrocarbon variety; and the carbon-silicon carbide 'couple which appears to be useful up to at least 3270 F (1800 C).<sup>13</sup>

<sup>13</sup> See G. R. Fitterer, *Trans. A.I.M.E.*, **105**, 1933, 290–297; *ibid.*, **120**, 1936, 189–202.

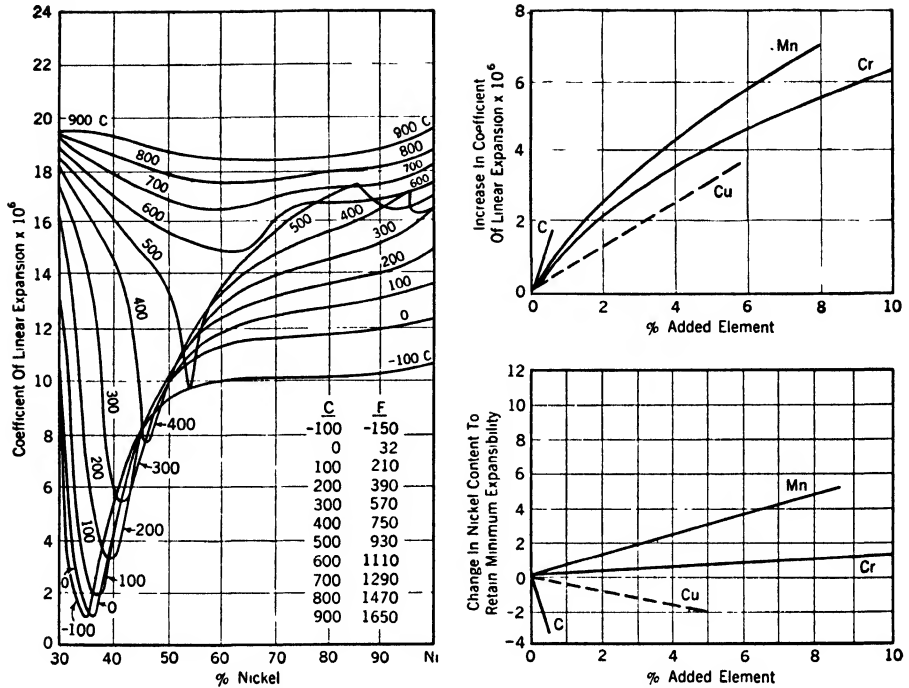


FIGURE 540a. (Left) Effect of composition on the coefficient of linear expansion of nickel-iron alloys (0.4% manganese and 0.1% carbon) at various temperatures in the range  $-100^{\circ}\text{C}$  ( $-150^{\circ}\text{F}$ ) to  $900^{\circ}\text{C}$  ( $1650^{\circ}\text{F}$ ).

b. (Upper right) Increase in coefficient of linear expansion by the addition of other metals.

c. (Lower right) Change in nickel content required to retain minimum coefficient of expansion as other metals are added. (After C. E. Guillaume.)

### *Alloys Used Because of Their Thermal Expansion Characteristics*

The peculiar thermal expansion properties of the iron-nickel alloys,<sup>14</sup> shown in Fig. 540, have resulted in many interesting applications. Most of these applications will fall in one of two classifications:

1. *Alloys having almost zero expansion at atmospheric temperatures*, which find use for absolute standards of length, rods and tapes for geodetic work, compensating pendulums and balance wheels in watches and clocks, controlling the expansion of moving parts such as some little-used types of aluminum-alloy automotive pistons, and for thermostatic bimetal strip.

<sup>14</sup> See also *The Alloys of Iron and Nickel*, Vol. I, by J. S. Marsh: McGraw-Hill Book Company, Inc., New York, 1938, Chap. VI.

2. *Alloys having an expansion within relatively narrow limits in certain ranges of temperature*, for use in glass-to-metal seals, for lead-in wires in electric-light bulbs and radio tubes, or to replace more costly metals.

#### ALLOYS HAVING VERY LOW EXPANSION COEFFICIENTS

Probably the best known member of this group is the alloy *Invar*,<sup>15</sup> first developed by C. E. Guillaume, in France. The same alloy also is used under the name of *Nilvar*, *Nilex*, and *Indilitans*. Essentially, it is an iron alloy containing 36% nickel, although the original composition also contained 0.4% manganese and 0.1% carbon. In addition to its low expansion in the atmospheric temperature range, the alloy has a high corrosion resistance, high strength, and good shock resistance, all valuable characteristics. The microstructure is austenitic and shows the twinned crystals typical of such structures.

In commercial alloys the effect of impurities must be considered as they exert a marked influence on the expansivity. The presence of manganese, chromium, silicon, tungsten, or molybdenum causes the minimum expansion to shift toward higher nickel contents than the normal 36%, whereas copper, carbon, or cobalt cause the minimum to shift toward lower nickel contents. Consequently, the impurities must either be kept to a minimum or else be balanced properly. These effects also are illustrated in Fig. 540*b* and *c*.

Heat-treatment and cold-work also affect the expansivity (inches per inch per degree) appreciably, as indicated by the following data of the Bureau of Standards.

	HOT ROLLED, $\times 10^6$		COLD DRAWN, $\times 10^6$	
	PER °C AT 20 C	PER °F AT 68 F	PER °C AT 20 C	PER °F AT 68 F
As worked	1.2	0.7	0.3	0.2
Annealed	1.7	0.9	1.2	0.7
Quenched	0.7	0.4	0.7	0.4

After cold-working, the expansion will increase with the temperature of subsequent annealing up to about 1100 F (600 C), the temperature at which the maximum value is attained. As indicated above, this nullifies the im-

<sup>15</sup> See also H. Scott, *Trans. Amer. Soc. Steel Treat.*, 13, 1928, 829-847.

provement in the expansion produced by cold-work. The best heat-treatment to remove strains completely is a quench from 1400–1500 F (760–820 C).

Invar retains its low-expansion characteristics within relatively narrow temperature limits. In addition it is also extremely susceptible to fluctuations or variations in treatment. These will result in irregular or transitory changes in dimensions over long periods of time. For greatest stability, the forged bars must be cooled slowly through the range 200–70 F (100–20 C) over a period of several months and then aged for a long time at room temperature. This treatment is not required, however, except for the most accurate instruments.

In the hot-rolled or forged condition, the alloy will have a tensile strength of 65,000–85,000 psi, with a yield point of 40,000–60,000 psi, an elongation of 30–45%, and a reduction in area of 55–70%. The Brinell hardness will be about 160.

The use of 4–6% cobalt, with 31% nickel and the remainder iron, gives the alloy *Super Nilvar*, or *Super Invar*, which has a zero coefficient of expansion in the hot-rolled condition.<sup>16</sup>

A cast iron having these general characteristics has been developed recently and is sold as *Invar Cast Iron* or *Minovar*.<sup>17</sup> Basically it is a close grained gray cast iron containing 34–36% nickel which combines the many excellent characteristics of gray iron with a very low coefficient of thermal expansion.

To meet a need for a combination of low-expansion and precipitation-hardening characteristics the *Ni-Span-Lo*<sup>18</sup> alloys recently have been made available commercially. These are low-carbon (0.06%) iron-base alloys containing 41–52% of nickel, 2.3% of titanium, and 0.3–0.4% of manganese, silicon and aluminum. Solution treatments of 1–1½ hr in the range 1700–1850 F (925–1000 C) are required with rapid cooling in oil or water. This must be followed by an aging treatment for 8–24 hr in the range 1225–1300 F (660–700 C), the optimum temperature being determined largely by the nickel content. By properly combining cold-work and heat-treatment, a tensile strength as high as 195,000 psi can be secured, combined with a yield strength (0.2% offset) of 165,000 psi, and a modulus of elasticity of  $22.5 \times 10^6$  psi.

<sup>16</sup> See also H. Scott, *Trans. A.I.M.E.*, **89**, 1930, 506–537.

<sup>17</sup> International Nickel Company tradename. See also F. G. Seifing and D. A. Nemser, *Product Engineering*, November 1945.

<sup>18</sup> Covered by U. S. Patents assigned to the International Nickel Company, Inc. Additional data are given by N. B. Pilling and A. M. Talbot, *Symposium on Age Hardening of Metals*, A.S.M., Cleveland, Ohio, 1939.

## ALLOYS HAVING CONTROLLED EXPANSION COEFFICIENTS

For such purposes as glass-to-metal seals, alloys are required having expansion coefficients identical with those of the glass used in certain ranges of temperature. Otherwise, the joint will crack or open on cooling because of the strains produced in the glass. Several alloys have been developed for this purpose, among them *Kovar* and *Fernico* containing, nominally, 54% iron, 23–30% nickel, 17–30% cobalt, and 0.6–0.8% manganese. For sealing wires in glass, several alloys also have been developed, such as *Platinite*, a 46% Ni–54% Fe alloy, which has almost the same expansion as platinum and hence can be used to replace it for lead-in wires in electric-light bulbs and radio tubes; *Dumet*, a comparatively expensive composite material consisting of a 40% Ni–60% Fe alloy, around which an oxidized copper sleeve is drawn; *Fernichrome*, an expensive alloy, difficult to make and control, containing 37% Fe–30% Ni–25% Co–8% Cr; and *446* or *55* alloy, containing 27–30% chromium and 73–70% iron. Frequently, however, it is found that these materials will give strain-free seals only with certain specific glass compositions. Some of these difficulties have been overcome commercially by the use of an alloy containing 42% nickel, 4% molybdenum and the remainder iron with the usual impurities,<sup>19</sup> or of the alloy consisting of 42% nickel, 6% chromium, 0.52% carbon, in addition to iron and the usual impurities.<sup>20</sup> Other iron alloys also have proved to be satisfactory for particular types of glasses. For example, radio power tubes frequently are made of a low-expansion glass which is matched almost exactly by the 39% Ni–61% Fe alloy in the temperature range 30–840 F (0–450 C).

In industrial measuring machines, used for testing the dimensions of steel gauges and machine parts, an alloy is desired which is stable, highly resistant to corrosion, and which has the same coefficient of expansion as ordinary steel in order that temperature corrections will be unnecessary. The 56% Ni–44% Fe alloy satisfies the requirements for this purpose.

The range of expansions possible in the iron-nickel alloys or relatively simple modifications of them is so varied that almost any requirements can be met by a proper study of these materials.

For applications such as thermostatic bimetals it is usually desirable to combine a high-expansion and a low-expansion alloy. As a high-expansion mate to low-expansion precipitation-hardening alloys of the Ni-Span-Lo type, a low-carbon alloy containing 29% Ni–8.5% Cr–2.4% Ti–0.4% Mn–0.4% Si–0.4% Al–rem. Fe, recently has been developed. This is

<sup>19</sup> Carpenter Steel Co.

<sup>20</sup> See W. E. Kingston, *Trans. A.S.M.*, **30**, 1942, 47–67, for a very complete discussion.

*Ni-Span-Hi*,<sup>21</sup> which has a coefficient of expansion that is near the maximum possible with a ferrous alloy, viz., mean  $10.5 \times 10^{-6}$  per °F from room temperature to 1000 F (540 C) and varying from about  $10 \times 10^{-6}$  at the lower temperatures to about  $11 \times 10^{-6}$  at the higher. It will precipitation-harden after treatments similar to those used for the Ni-Span-Lo alloy.

#### ALLOYS WITH LOW THERMAL COEFFICIENTS OF ELASTICITY

For springs in fine watches and in precision testing and weighing equipment, and for tuning forks used for frequency standards in radio engineering, an alloy is needed that will have a zero coefficient of elasticity within the range of atmospheric temperatures. In a watch spring, for example, the changes in this coefficient in the temperature interval between 32 and 86 F (0–30 C) may result in an error of the order of 1 sec per hr.

Invar possesses the *highest* thermal coefficient of elasticity of any of the iron-nickel alloys, about  $278 \times 10^{-6}$  per °F ( $500 \times 10^{-6}$  per °C). Two iron-nickel alloys, containing exactly 29% and 45% nickel, have zero thermo-elastic coefficients at 68 F (20 C), but both compositions are so sensitive to slight variations in nickel content that, practically, the fact has little value. However, by replacing 12% of the iron with chromium in the 36% nickel Invar alloy, an alloy, called *Elinvar*<sup>22</sup> or *Iso-elastic Alloy*, is produced which is much less sensitive to variations in nickel content than the straight iron-nickel alloys. Analyses of commercial alloys of this type generally fall within the limits:

% NI	% FE	% CR	% W	% MN	% SI	% C
33–35	61–53	4–5	1–3	0.5–2	0.5–2	0.5–2

An approximation of the percentage change in stiffness for a 200° F change in temperature is given in Table L for some of the commonly used spring materials.

By using a properly designed bimetallic spring,<sup>23</sup> one section of which is 36% Ni–64% Fe and the other any desirable spring material depending on the properties needed, it is possible to produce any temperature modulus coefficient desired between +6.4 and –5%.

<sup>21</sup> Covered by U. S. patent No. 2,048,167 assigned to the International Nickel Company, Inc.

<sup>22</sup> See also G. E. Shubrooks, *Metal Progress*, February 1932, p. 58.

<sup>23</sup> See U. S. Patent No. 2,236,158.

TABLE L APPROXIMATE PERCENTAGE CHANGE IN STIFFNESS OF SOME OF THE COMMONLY USED SPRING MATERIALS FOR A 200° F CHANGE IN TEMPERATURE

High-carbon steel	2.8%
Piano wire	3.0
5% nickel steel	3.2
Chromium-vanadium steel	3.0
18:8 stainless steel	5.0
Monel metal	3.2
Nickel silver	3.8
Beryllium copper	3.8
Phosphor bronze	4.2
Brass	4.4
Elinvar	0.8

The recently developed *Ni-Span-C* alloys<sup>24</sup> are also of this constant modulus type but have been made age hardenable by the addition of titanium. In the usual range of compositions 4.6–6.3% chromium may be added to the base 42% Ni–2.4% Ti–0.4% Mn–0.5% Si–0.4% Al–0.06% C–rem. Fe depending on whether a zero thermoelastic coefficient or a controlled positive or negative coefficient is desired. With these materials a relatively high solution treatment is required, viz., 1–1½ hr at 1750–1825 F (950–1000 C), followed by rapid cooling in oil or water. Aging for the proper time in the range 1100–1350 F (600–725 C) then will give a combination of properties in the range:

Modulus of elasticity, psi	26.5 – 27 × 10 <sup>6</sup>
Modulus of rigidity, psi	10 × 10 <sup>6</sup>
Tensile strength, psi	150,000–180,000
Yield strength (0.2% offset), psi	95,000–115,000
Elongation, %	30–17
Brinell hardness (10 mm–3000 kg)	300–345

These properties all are subject to considerable modification by both cold-work and heat-treatment.<sup>25</sup> Under the name *Elinvar Extra*, this alloy, with 5.1–5.7% chromium, also is being used for hairsprings by the Hamilton Watch Company.

Another recently developed alloy, *Elgiloy*, was intended primarily for use as watch mainsprings by the Elgin National Watch Co., and hence is probably of this general type. Although very little information has been

<sup>24</sup> Covered by U. S. patents No. 2,048,167 and 2,266,482, assigned to the International Nickel Company, Inc.

<sup>25</sup> N. B. Pilling and A. M. Talbot discuss these well in *Symposium on Age Hardening of Metals*, A.S.M., Cleveland, Ohio, 1939.



released on it, it is reported to contain 20% Cr-40% Co-15.5% Ni-15% Fe-7% Mo-2% Mn-0.15% C-0.03% Be; and to have an ultimate tensile strength of 368,000 psi, with a yield strength (0.02%) of 280,000 psi, a proportional limit of 233,000, and Vickers hardness of 702 in the form of springs. The alloy is very workable, both hot and cold, nonmagnetic, and very corrosion resistant. It also is reported that one of its chief virtues is that a main spring made from it will deliver the same torque whether the watch is wound up or run down.

### *Alloys Used Because of Their Low Melting Range*

Alloys of this type are extremely varied, both as to composition and melting range because of the wide range of applications they fill. Three different groups will be considered:

1. *Fusible alloys*, including the soft solders
2. *Silver solders*, sometimes called *hard solders* or *silver brazing alloys*
3. *Brazing alloys*, including both the brazing solders and the so-called bronze welding rods

#### FUSIBLE ALLOYS

By alloying bismuth, cadmium, lead, tin, and mercury in varying amounts, it is possible to produce alloys which will melt, or begin to melt, at almost any desired temperature between 140 and 360 F (60-180 C).<sup>26</sup> Many of these alloys owe their low melting points to the formation of binary, ternary, or polynary eutectics, and, consequently, melt at a nearly constant temperature. The addition of mercury, in particular, tends to lower the melting points appreciably. Alloys containing over 50% bismuth have the added advantage of expanding slightly during solidification. This property is very valuable when detail is to be reproduced. The addition of indium also lowers the melting points markedly but makes the alloys considerably more expensive. The commercial *Cerrolow* indium alloys melt in the range 105-175 F (40-80 C); and the *Cerroseal* alloys melt at 245 and 295 F (120 and 145 C).

#### SOFT SOLDERS

The principal use of the low melting alloys is for soft solders,<sup>27</sup> the stand-

<sup>26</sup> Considerable specific data are given by K. R. Van Horn, *Metal Progress*, May 1932, p. 65; and E. J. Daniels, Tech. Pub., Series B, No. 5, Int. Tin Research and Development Council, London, 1937.

<sup>27</sup> See also J. L. Miller, *Met Ind.*, 57, 1940, 82-86.

ard compositions of which are covered by A.S.T.M. Tentative Standard B32-T and S.A.E. Nos. 1, 2, 3, 4, 5, and 6. There are ten A.S.T.M. tin-lead and tin-lead-antimony alloys with two grades differing in allowable impurity content, Grade A being the purer. An appendix to this standard gives an excellent table of solidus and liquidus temperatures for tin-lead and tin-lead-antimony alloys. The term *soft solders* usually is restricted to alloys flowing, i.e., liquidus temperature, below 700 F (370 C).

The conventional nomenclature usually adhered to in the industry refers to the weight per cent tin first, the weight per cent lead second, and the weight per cent antimony, if present, third. Thus a 40:60 solder means 40% Sn-60% Pb, and 38:60:2 means 38% Sn-60% Pb-2% Sb.

#### TIN-LEAD SOLDERS

The tin-lead alloys which have been the standard soft solders for many years are characterized by an eutectic at 62% Sn-38% Pb melting at 361 F (183 C) and a solid solubility at the eutectic temperature of about 19.5% tin in lead and 2.5% lead in tin. Solid solubility at room temperature is very low in both instances. The constitutional diagram is shown in Fig. 541.

Before World War II the compositions most commonly used for solders applied with an iron or torch, for dip soldering in a bath of molten solder, or for "sweating" were 50:50 and 40:60, melting (solidus temperature) at 361 F (183 C) and flowing (liquidus temperature) at about 420 F (215 C) and 460 F (240 C), respectively. These compositions were applied more easily and had a greater fluidity than the lower tin alloys. The 30:70 and 20:80 compositions, flowing at 495 F (255 C) and 545 F (285 C), respectively, although they could be used entirely satisfactorily for most applications, required much more care in preparing the surfaces to be soldered and an entirely different soldering technique because of their higher flow temperatures and lower fluidity.<sup>28</sup> In addition, the high-lead solders are difficult to use for joining large assemblies because of the long freezing range during which dimensional changes tend to destroy the joint. The high-lead alloys are essentially wiping solders.

In Fig. 542 are shown photomicrographs illustrating the metallographic structures of the tin-lead alloys, and in Fig. 543 photomicrographic cross sections through lap joints soldered with the 30:70, 40:60, and 50:50 alloys.

Wiping solders,<sup>29</sup> used for joining sections of lead pipe or lead cable sheathing in preference to lead burning, or for connecting lead pipe to cop-

<sup>28</sup> These are discussed thoroughly in *Tin Solders*, 2d ed., by S. J. Nightingale (revised by O. F. Hudson): British Non-Ferrous Research Assoc., London, 1942.

<sup>29</sup> The properties of these are discussed by D. A. McLean, R. L. Peek, Jr., and E. E. Schumacher, *Journ. Rheology*, 3, 1932, 53.

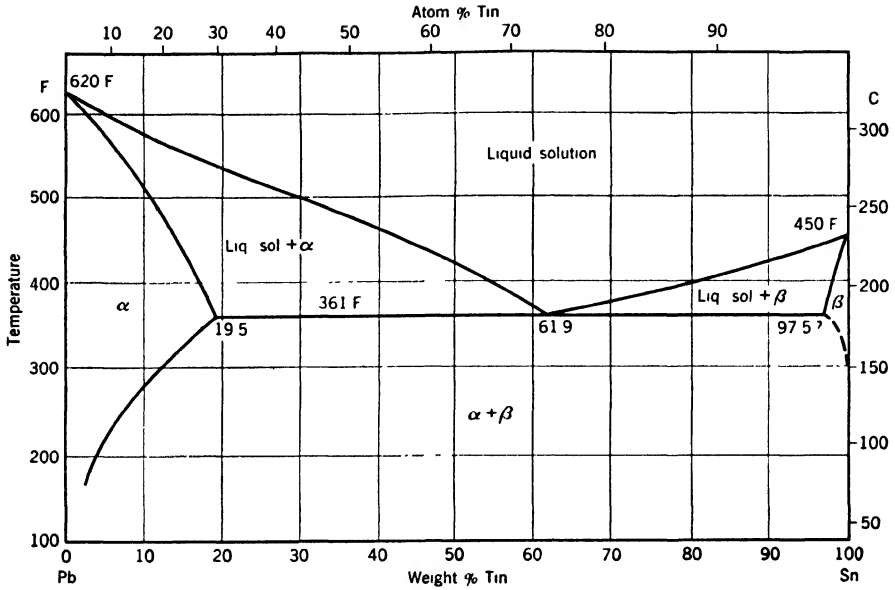


FIGURE 541. Constitutional diagram for the alloys of lead and tin: the soft solders. (After M. Hansen.)

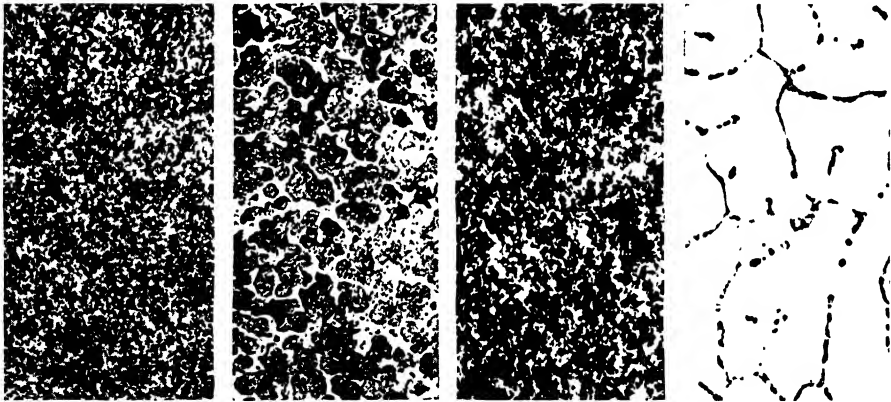


FIGURE 542. Metallographic structures of tin-lead solders.  $\times 100$ . (Photomicrographs by L. Litchfield.)

- (Left) 10:90 solder. Etched with glacial acetic acid. Tin-rich solid solution precipitated in finely divided form in lead-rich solid solution matrix. Note that no eutectic forms during the solidification of this alloy.
- (Left center) 30:70 solder. Etched with 5% nital. Eutectic (light) at boundaries of lead-rich solid solution within which tin-rich solid solution has precipitated as the alloy cooled.
- (Right center) 50:50 solder. Etched with 5% nital. Eutectic (light) at boundaries of lead-rich solid solution.
- (Right) 90:10 alloy. Etched with 5% nital. Eutectic (dark) at boundaries of tin-rich solid solution.

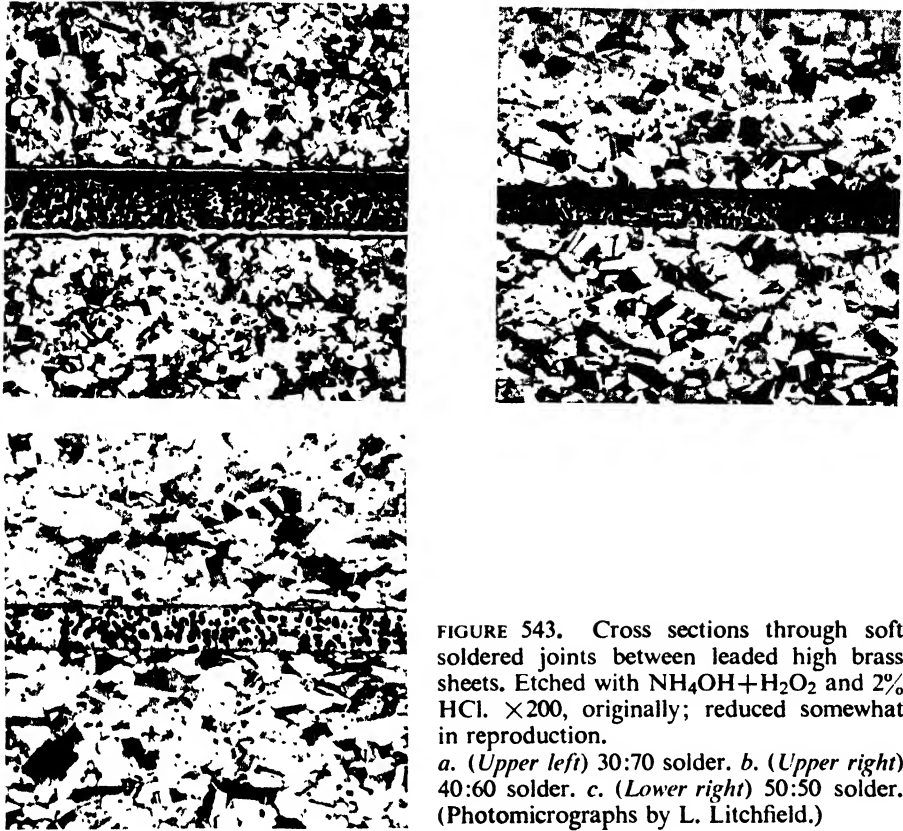


FIGURE 543. Cross sections through soft soldered joints between leaded high brass sheets. Etched with  $\text{NH}_4\text{OH} + \text{H}_2\text{O}_2$  and 2%  $\text{HCl}$ .  $\times 200$ , originally; reduced somewhat in reproduction.

*a.* (Upper left) 30:70 solder. *b.* (Upper right) 40:60 solder. *c.* (Lower right) 50:50 solder. (Photomicrographs by L. Litchfield.)

per-alloy fittings, generally contained 42–37% tin and 58–63% lead although up to 2% antimony sometimes was added. If the solder was used to fill joints in automobile bodies, 30:70 usually was preferred. For this type of application the solder is manipulated or wiped over the joint by hand while it is in a pasty condition, viz., between the liquidus and solidus temperatures, so a fairly extended range of partial liquefaction without too high a flow temperature is desirable.

#### SUBSTITUTE SOLDERS

When the supply of tin was cut off in the early days of World War II, and it became imperative to reduce its consumption, considerable study was given both to increasing the utility of the lower tin solders by decreasing their flow temperatures and increasing their fluidity and to developing solders containing no tin at all.

By adding about 1.5% silver, 3% bismuth, and 0.5% antimony in place

of lead the flow temperature of the 20:80 composition is reduced to about 495 F (260 C) or about equal to that of the regular 30:70 alloy.<sup>30</sup> Likewise, the addition of 1% silver to the 30:70 composition reduced its flow temperature to about 480 F (250 C) making it somewhat easier to apply. By using proper care in surface preparation, alloys of this type could be used entirely satisfactorily. However, unless the additional elements were added, little tin was saved in this manner by reducing the composition below 30:70 and there is some question if even this ratio is not too low. These less fluid solders, and the more troublesome techniques required to apply them, tend to give thicker and, consequently, weaker joints which have, as a rule, much rougher surfaces than the usual joints. When the greater amount of solder used and the poorer quality of the work are balanced, no real saving of tin results.

Many alloys containing cadmium can serve as adequate substitutes without appreciable increase in cost<sup>31</sup> but their over-all properties are not good enough to make them serious competitors when tin is available and the supply of cadmium is not great enough to use it for this purpose in times of extended emergency.

Probably the most important substitute solder if tin is to be eliminated entirely is the eutectic alloy of lead with 2.5% silver, to which about 0.25% copper has been added. This alloy, as well as the 97.5% Pb-1.5% Ag-1% Sn composition, is included in A.S.T.M. Tentative Standard B32-T. A photomicrograph of this alloy is shown in Fig. 544 along with a cross section through a lap joint soldered with it. The more expensive 95% Pb-5% Ag alloy is almost as good although it flows at a higher temperature than the alloy containing less silver.

The biggest disadvantages of the lead-silver solders are their low fluidity and their high melting range. Their melting temperature is about 570 F (300 C) and their flow temperature about 660 F (350 C), both appreciably higher than those of the tin-lead solders. When cold-worked copper is soldered with these lead-silver alloys it will be annealed because of the relatively high temperatures required. This is often undesirable although even the 50:50 tin-lead solders will anneal copper too, but to a much less degree.

In addition, joints made with the lead-silver alloys have neither the room-temperature strength nor the bright appearance of those made with the tin solders. They do have one advantage, however, which is not generally realized. When a 50:50 solder joint starts to fail, it fails suddenly and with a brittle fracture, as in opening a sardine can, for example. Joints made with a lead-silver solder, however, are just about as resistant to tearing after

<sup>30</sup> See S. Turkus and A. A. Smith, Jr., *Metals and Alloys*, **15**, 1942, 412-413.

<sup>31</sup> This is discussed thoroughly by F. N. Rhines and W. A. Anderson, *Metals and Alloys*, **14**, 1941, 704-711.

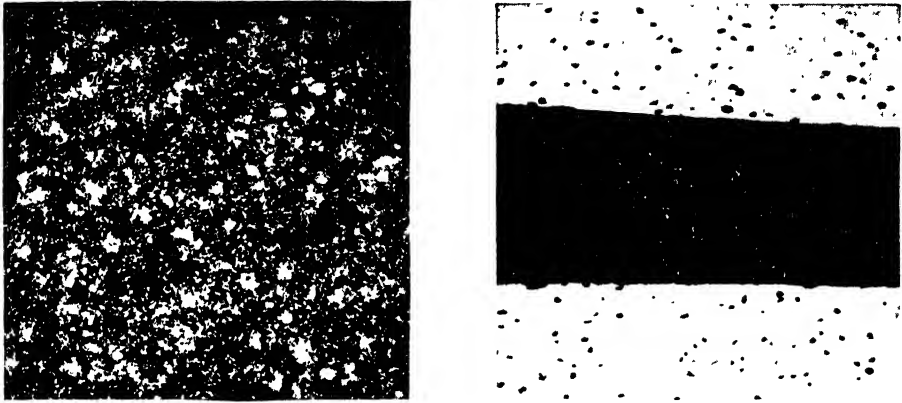


FIGURE 544a. (Left) Metallographic structures of 97.25% Pb - 2.5% Ag - 0.25% Cu solder. Etched with 2% nital.  $\times 300$ .  
 b. (Right) Cross section through soldered joint between leaded high brass sheets made with 97.25% Pb - 2.5% Ag - 0.25% Cu solder. Etched with 2% nital.  $\times 200$ , originally; reduced about one half in reproduction.  
 (Photomicrographs by L. Litchfield.)

failure starts as they are initially. This is largely the result of the failure of the lead-silver alloys to form intermetallic compounds with either copper or iron, the usual materials soldered.

The creep strength of the lead-silver solders in shear is much higher than that of the 50:50 solder, and it is retained well up to at least 325 F (160 C). Furthermore, because of the low alloying tendency between lead and copper there is practically no deterioration of the bond with time. When solders having constituents which tend to diffuse readily into copper alloys are used in this temperature range deterioration of the bond with time often has been a serious matter.

These alloys have been very successful for many applications, but, except under compulsion, most former users of tin solders will probably be unwilling to go to the trouble of learning the more difficult techniques required to use the lead-silver alloys successfully.

#### SOFT SOLDERS WITH LOWER MELTING POINTS

When assemblies must be soldered in which there are materials that might be damaged by heat, such as wax-filled condensers, for example, one of the lower melting point alloys must be used.

Some good solders for pewter and other low-melting alloys are listed in Table LI on p. 864.

TABLE LI COMPOSITIONS OF SOME LOW-MELTING ALLOYS

	% BI	% SN	% PB	% CD	MELTING POINT	
					F	C
<i>D'Arcet's alloy</i>	50	25	25	—	199.4	93
<i>Newton's alloy</i>	50	18.75	31.25	—	201.2	94
<i>Rose's metal</i>	50	22	28	—	212	100
—	12.5	37.5	50	—	352.4	178
<i>Bismuth solder</i>	25	50	25	—	—	—
<i>Wood's metal</i>	50	12.5	25	12.5	154.4	68

D'Arcet's alloy possesses the peculiar property of expanding regularly from 90–200 F (30–95 C) when heated, and then contracting gradually with increasing temperature up to 270 F (130 C) where its volume is less than it was at 90 F. Above 270 F (130 C) expansion continues regularly. The other alloys also expand on cooling, a property that makes them useful for taking impressions from dies.

Several of the fusible alloys, such as Wood's metal, wet glass, and melt at such low temperatures that they can be used safely to make seals and gas-tight joints in glass apparatus.

#### ALLOYS FOR SAFETY SYSTEMS

In automatic sprinkler systems, fire doors and alarms, and similar installations, the melting of a fusible alloy operates the equipment. By proper selection, an alloy can be found to melt at almost any desired temperature up to 360 F (180 C). In addition to their melting points, however, these alloys must be stable and homogeneous in order to give constant and reproducible results, and must have sufficient mechanical strength to hold the components together until fire occurs and their melting temperature is reached.

A somewhat similar application is the plug in chlorine containers where corrosion resistance and structure determine the reliability. For this purpose a chill cast *Lipowitz alloy*, a modified Wood's metal containing 50% Bi–13.3% Sn–26.7% Pb–10% Cd, and melting at 155 F (68 C) seems to give satisfactory results.

The boiler safety plugs, which are screwed into a boiler at the lowest safe water level to prevent steam pressure from building up, have been made of pure tin, melting at 450 F (232 C). These are entirely satisfactory and re-

liable, except when other factors, such as the formation of scale inside the boiler, prevents them from operating properly by insulating them.

#### ALLOYS FOR MISCELLANEOUS APPLICATIONS

In the machine shop, *Matrix alloy*, containing 14.5% Sn–48% Bi–28.5% Pb–9% Sb and melting at 220 F (105 C), is used for mounting and holding the various parts of compound dies, punches, jigs, and fixtures. This metal also expands slightly on solidifying and has a tensile strength of about 13,000 psi. For these reasons, it is an excellent alloy for the construction of parts for experimental machinery, and also is used extensively in the production of molds and dies for pressing wood composition and fiber in order to imitate wood carvings. Because of its low melting temperature it can be poured directly against the master wood carving without injuring it. Commercially it also is available under the name *Cerromatrix*.

The eutectic alloy containing 44.5% Pb–55.5% Bi, melting at 255 F (125 C), is very fluid when molten and may be cast into sand, plaster, wood, or paper molds. When castings of intricate shape or thin sections are desired, sharp reproduction is possible because the alloy has almost zero shrinkage. Among the commercial brand names for this composition are *Basaloy* and *Cerrobase*.

The *modified Wood's metal* composition mentioned above, containing 50% Bi–13.3% Sn–26.7% Pb–10% Cd and melting at 155 F (68 C), is sold commercially under the name *Cerrobend* for use in bending thin-walled tubes without crimping and buckling. For best results the alloy should be solidified by chilling in order to produce a fine-grained structure. This alloy also is used in the manufacture of hollow sterling silver ware. An oversize silver tube is filled with the alloy and then swaged between dies to the desired shape and size after which the filling can be melted out in boiling water and reused. Without this form of backing it would be very difficult to form the thin metal without breakage.

*Dental amalgams* usually range 66.6–68.7% silver, 26.1–28.2% tin, 4.6–5.1% copper, 0.2–1.7% zinc, although the alloy specified by the American Dental Association contains a minimum of 65% silver and 25% tin, and a maximum of 8% copper and 2% zinc. To this base mixture, the dentist adds the correct quantity of mercury and mixes the two carefully. The amalgam alloy consists largely of the compounds  $\text{Ag}_3\text{Sn}$  and  $\text{Cu}_3\text{Sn}$ , which are changed by the mercury to  $\text{Ag}_3\text{Hg}_4$ ,  $\text{SnHg}_3$ , and  $\text{Cu}_3\text{Hg}_2$ . The excess mercury is squeezed out, leaving the intermetallic compounds. If the original mixing is not efficient enough, the reactions may continue in the tooth, thus resulting in appreciable, harmful, and often painful, dimensional changes.



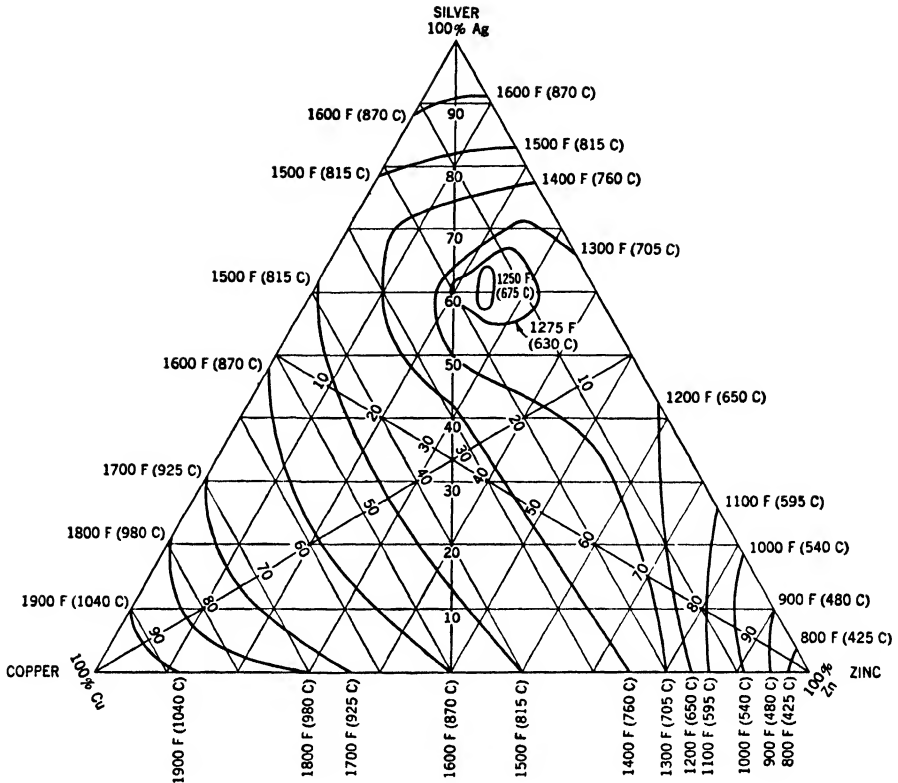


FIGURE 545. Liquidus isotherms for the system copper-silver-zinc, indicating the minimum flow temperatures of silver brazing alloys. (From Appendix to A.S.T.M. Standard B73, courtesy American Society for Testing Materials.)

#### SILVER BRAZING ALLOYS

The important commercial silver solders or silver brazing alloys are covered by A.S.T.M. Standard B73 in eight grades varying in composition from 10–80% silver, 52–16% copper, 38–4% zinc and 0–5% cadmium but many other variations are used. The addition of silver to binary copper-zinc alloys lowers their melting range, giving a series of ternary alloys that will flow freely between 1250 and 1600 F (680–870 C), as shown in Fig. 545. The low-silver alloys, in general, have high melting ranges and the high-silver alloys good workability.<sup>32</sup> The alloys vary from yellow to white in color. Cadmium, tin, nickel, manganese, and chromium sometimes are added in small amounts for special purposes.

*Gold solders*, usually alloys of gold, silver, copper, and zinc or cadmium,

<sup>32</sup> See also J. L. Miller, *Met. Ind.*, 57, 1940, 109–110.

are very similar to silver solders in both microstructure and properties. Usually they contain 25–50% gold (6–12 karat).

Special silver brazing alloys have been developed for applications in which a melting point lower than those of the standard compositions is desired. Two of the most common of these, both proprietary alloys, are:

	% AG	% CU	% ZN	% CD	% P	MELTING RANGE F	RANGE C
<i>Sil-Fos</i>	15	80	—	—	5	1190–1300	645–705
<i>Easy-Flo</i>	50	15.5	16.5	18	—	1160–1175	630–635

The cadmium in *Easy-Flo* may be reduced as low as 10% if necessary without disturbing the melting range greatly, provided the remainder of the composition is balanced properly. The other characteristics of this low-cadmium alloy are somewhat inferior to those of the standard alloy, however. Two other alloys of this type, *Easy-Flo 45*, with a flow point of 1145 F (620 C), and *Easy-Flo 35*, with a flow point of 1295 F (700 C) are recent developments. The number indicates the silver content.

The silver brazing alloys are used for joining all types of ferrous and non-ferrous alloys because of their strength, melting point, free-flowing characteristics, and corrosion resistance. The strongest joints are made with small clearances, as illustrated previously in Fig. 343, a statement which also applies equally well to the soft solders.

The metallographic structures of these alloys may be of either of two types depending on the composition. The high-silver alloys, which usually contain only moderate amounts of zinc, are modifications of the silver-copper eutectic structure (Figs. 546*a* and *b*) with a silver-rich phase and a copper-rich phase. The low-silver alloys, in which the zinc content has to be considerably greater in order to increase the fluidity and lower the melting range sufficiently, are modifications of the 60% Cu–40% Zn, Muntz metal, structure (Fig. 546*c*) with both an  $\alpha$  and a  $\beta$  phase.

The appearance of a cross section of a typical silver brazed joint is shown in Fig. 547*a*. The solder structure seen, however, is more nearly that of a gold solder than of a silver solder. The molten solder tends to dissolve the metals with which it is in contact until it attains a composition which is in essential equilibrium with them at the soldering temperature. In some instances, as in the example shown, this may change its composition appreciably from that which was melted initially (cf. Fig. 547*a*). The rate of diffusion of solder into the metals joined (Fig. 547*a* and *b*) is appreciable

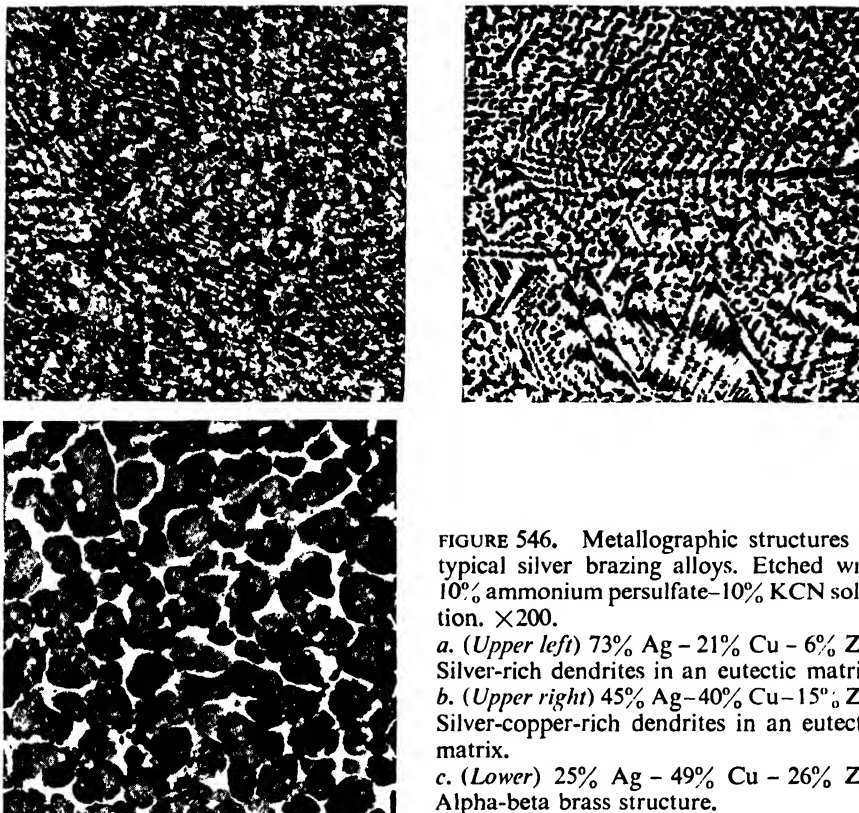


FIGURE 546. Metallographic structures of typical silver brazing alloys. Etched with 10% ammonium persulfate-10% KCN solution.  $\times 200$ .

- a. (Upper left) 73% Ag - 21% Cu - 6% Zn. Silver-rich dendrites in an eutectic matrix.  
 b. (Upper right) 45% Ag - 40% Cu - 15% Zn. Silver-copper-rich dendrites in an eutectic matrix.  
 c. (Lower) 25% Ag - 49% Cu - 26% Zn. Alpha-beta brass structure.

only at temperatures approaching and exceeding the melting range of the solder. Thus, if the molten solder is kept in contact with the metals too long appreciable diffusion may result.

If the metal being brazed is under stress while it is in contact with the molten alloy, stress-corrosion cracking may even result as illustrated for copper wire in Fig. 547c. This attack is analogous to the penetration of liquid mercury into hard-worked brass in the test for susceptibility to season cracking described in Chap. XI.

#### BRAZING ALLOYS

The commonest general purpose *brazing* or "*spelter*" *solders* are usually beta brasses, which melt within the range 1440-1620 F (780-880 C). Frequently, small amounts of deoxidizers, such as silicon or manganese, may be present and tin or iron sometimes may be added as a hardener or grain-growth inhibitor. The alloy is supplied in both the lump and the granular form, of a coarseness depending upon the application. Several compositions are covered by A.S.T.M. Standard B64. They may be yellow, gray, or black.

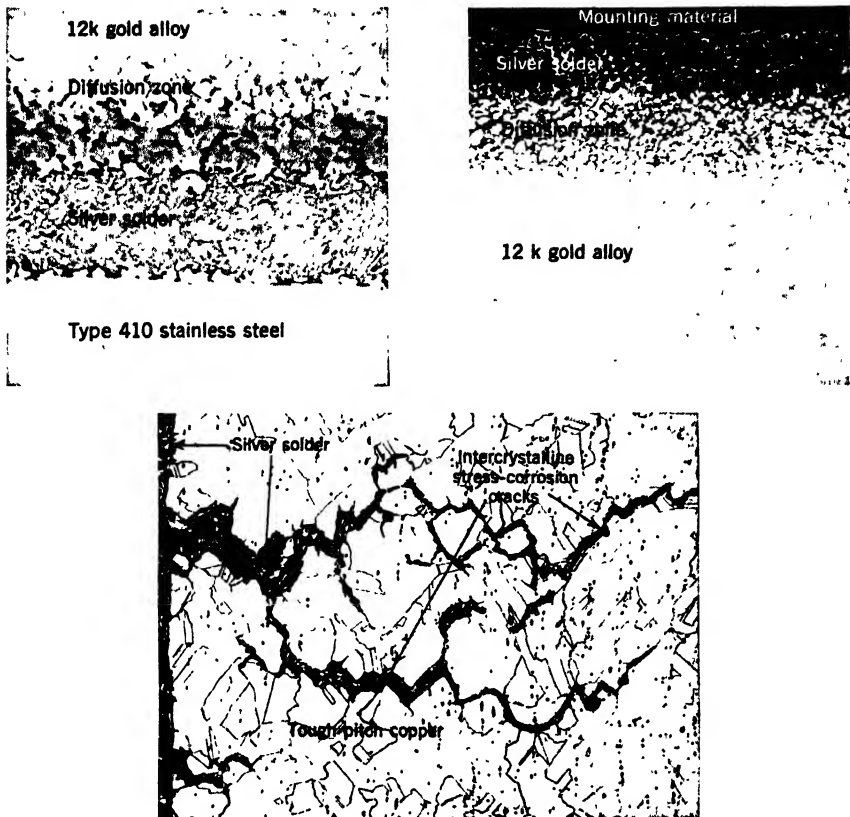


FIGURE 547. Silver brazed joints.

a. Relatively little diffusion in a normal joint. Etched with acetic-nitric etchant.  $\times 500$ .  
 b. Appreciable diffusion resulting from too long a time at soldering heat. Etched with 10% ammonium persulfate-10% KCN solution.  $\times 50$ . (Photomicrographs *a* and *b* by L. Litchfield.)

c. Stress-corrosion cracking resulting from the action of the liquid silver alloy on stressed tough-pitch copper wire. Etched with  $\text{NH}_4\text{OH} + \text{H}_2\text{O}_2$ .  $\times 200$ . (Photomicrograph courtesy Pittsfield Works' Laboratory, General Electric Company.)

*Bronze welding rods* are used widely for brass welding or brazing when strengths of about 50,000 psi are required, combined with satisfactory wear resistance, corrosion resistance, and a yellowish to reddish color. Most of these alloys are modifications of the 60% Cu-40% Zn, Muntz metal, alloy although in many instances welding rods are used which have compositions very similar to those of the metals which they join. Typical cross sections through some bronze-welded joints are shown in Fig. 548.

The term *copper brazing*<sup>33</sup> is used when steel is brazed by either pure- or phosphor copper in a reducing atmosphere at a temperature above the melting point of copper, 1980 F (1083 C). The metallographic structure of

<sup>33</sup> See, for example, H. M. Webber, *Trans. A.S.M.*, 18, 1930, 1144.

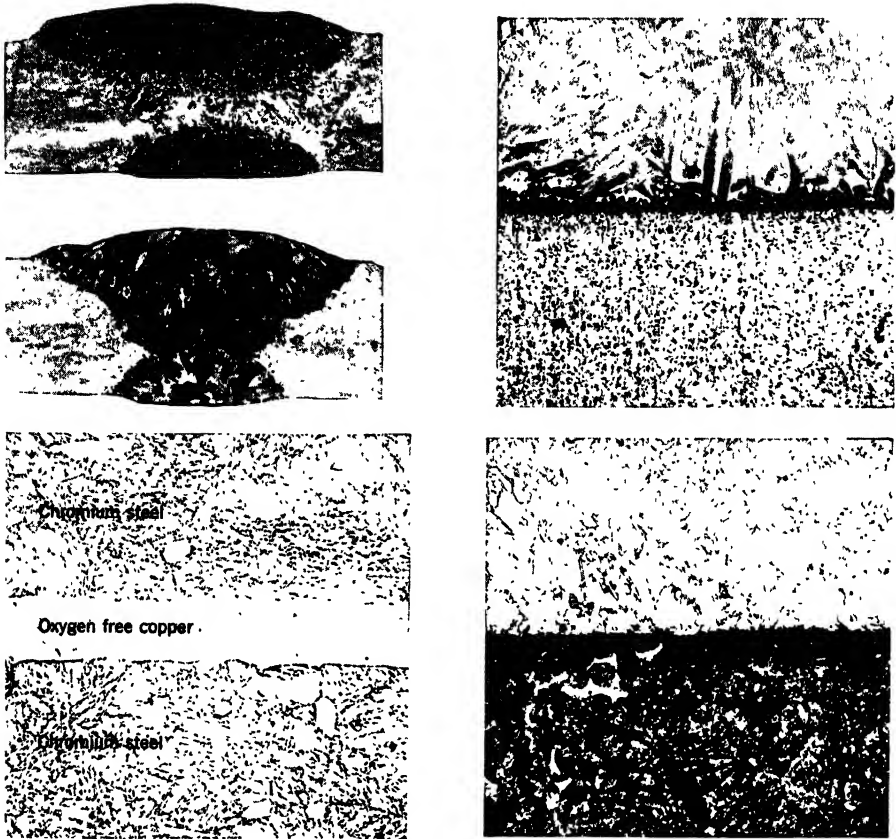


FIGURE 548a. (Upper left) Carbon-arc welds on 3/8-in. Muntz metal using low-fuming bronze (upper) and silicon bronze (lower) welding rod. Etched with  $\text{NH}_4\text{OH} + \text{H}_2\text{O}_2$ .  $\times 2.5$ . (Macrographs courtesy Chase Brass & Copper Co.)

b. Metallographic appearance of joint in bronze-welded steel (upper right) and in bronze-welded cast iron (lower right). Alpha-beta brass structures, such as these, are typical of most "bronze welds." Etched with  $\text{NH}_4\text{OH} + \text{H}_2\text{O}_2$ .  $\times 50$ .

c. (Lower left) Cross section through a chromium-steel joint that was brazed with oxygen-free copper in a reducing atmosphere. (Photomicrograph courtesy Westinghouse Electric Corp., Research Laboratories.)

a section through a chromium-steel joint made in this manner is shown in Fig. 548 also.

### *Magnetic Materials*

Two types of magnetic alloys are of particular commercial importance:

1. The *magnetically hard* alloys which are used in large quantities for permanent magnets in such applications as radio loud speakers and electrical measuring instruments.

2. The *magnetically soft* alloys which are used for core materials in a wide variety of electrical applications.

## STEELS FOR PERMANENT MAGNETS

Steels used for permanent magnets generally are made in the electric furnace, either arc or induction, followed by hot-rolling, although some of the intricately shaped magnets of the cobalt-steel types are cast in their final shape.<sup>34</sup> As a rule, the commonest types contain, in addition to iron, the elements shown in Table LII.

TABLE LII ANALYSES\* OF COMMON MAGNET STEELS

TYPE	% C	% MN	% CR	% W	% CO	% MO
Carbon	0.60	0.80	—	—	—	—
Chromium	0.60–1.00	0.35–0.60	1–6	—	—	0–0.35
Tungsten	0.70	0.30–0.50	0.20–0.50	5.5–6.0	—	—
Cobalt I	0.90	0.35	4.75	1.25	8.50	—
Cobalt II	0.90	0.30–0.85	3.5–5.75	3.75–7.0	35–41	—
Cobalt-chromium	0.95	0.30	9.00	—	16	1.30
Cobalt-tungsten	0.85	0.60	2.0–5.0	8.75	17	—

\*Maximum limits of 0.30% silicon, 0.03% phosphorus, 0.03% sulfur, and 0.50% nickel are maintained.

In these alloys, the iron and cobalt are apparently the elements which impart the magnetic characteristics. The carbon gives them hardness, both physical and magnetic; and the manganese, chromium, tungsten, and molybdenum serve mainly to increase the hardenability, thereby giving oil- or air-hardening rather than water-hardening characteristics to the alloys.

The correlation between microstructure and magnetic properties is not reliable, although decarburization is known to be undesirable. Good material generally will have a fine silky fracture.

The best magnetic results are secured if the number of times the alloy is reheated in passing from the ingot to the final magnet is kept to a minimum, although the reason for this is not known. Hardening is carried out at the temperature which gives the maximum value for the product of the residual magnetism,  $\beta_r$ , and the coercive force,  $H_c$ .<sup>35</sup> Permanent magnets with a high value of  $H_c$ , are very resistant to demagnetizing fields, an important item

<sup>34</sup> See also, K. L. Scott, *Metal Progress*, September, 1936, p. 64.

<sup>35</sup> See, for example, R. L. Dowdell, *Trans. A.S.M.*, **22**, 1934, 19.

in many applications. Depending upon the specific compositions, the hardening temperatures may range 1450–1750 F (790–950 C) as shown in Table LIII. However, this is influenced to some extent both by the design and by the quenching medium used.

As a rough approximation for a given application, the required length of a magnet is inversely proportional to  $H_c$ , and the required cross section inversely proportional to  $\beta_r$ . Oil quenching will give higher values of  $H_c$ , and lower values of  $\beta_r$ , than water quenching. It also will give much less warping, cracking, and breakage, and hence the oil-quenching steels are largely replacing the water-quenching ones.

TABLE LIII HEAT TREATMENTS USED FOR COMMON MAGNET STEELS

TYPE	HARDENING TEMPERATURE (F)	QUENCHING MEDIUM	$\beta_r$ (GAUSS)	$H_c$ (OERSTEDS)
Carbon	1450	Water	10,000	43
Chromium	1450–1550	Oil	9,000–10,000	50–72
Tungsten	1525–1550	Oil	9,000–10,000	65–70
Cobalt I	1650	Oil	9,000	70
Cobalt II	1700	Oil	7,500	120
Cobalt-chromium	Special heat-treatment	Air	8,000	180
Cobalt-tungsten	1750	Oil	9,000	165

#### PRECIPITATION-HARDENING MAGNET ALLOYS

The substantially carbon-free precipitation-hardening alloys can duplicate the properties of the permanent-magnet steels, and under some conditions will have coercive forces much higher than any of the commercial magnet steels. The alloys are still in process of development and the most promising, in the cast condition, appear to be those listed in Table LIV, the remainder of the composition being iron in each case.

The Alnico magnets containing no cobalt sometimes are referred to under the name *Alnic*. Both have approximately the same characteristics in small sections but the Alnico type has better properties in all sizes and sections and lends itself better to heat-treatment for uniformity.

The first three of these have a lower density and cost than the 36% cobalt magnet steel, but they can be neither forged nor machined. As a result, fabrication is limited to shapes that can be cast or produced by powder metallurgy, i.e., compressing and sintering a properly sized mixture of powder

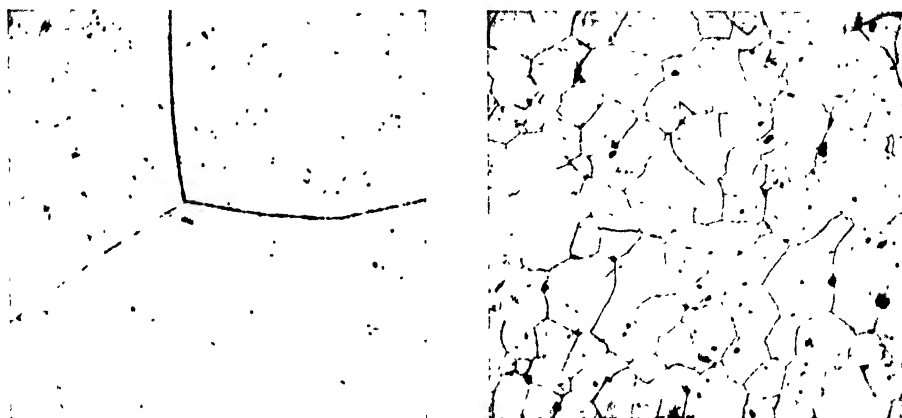


FIGURE 549. Metallographic structures typical of Alnico magnet alloys. Etched with HCl saturated with  $\text{CuCl}_2$  and diluted with an equal part of alcohol.  $\times 250$ .  
*a. (Left)* As cast, made by melting. Note the coarse grain size.  
*b. (Right)* Sintered, made by powder metallurgy. Note the fine grain size.  
 (Courtesy Research Laboratory, General Electric Company.)

TABLE LIV COMMON PRECIPITATION-HARDENING FERROUS MAGNET ALLOYS\*

TYPE	% NI	% AL	% CO	% CU	% MO	% TI	$\beta_r$ (GAUSS)	$\beta_{\max}$	$H_c$ (OERSTEDS)	$H_{\max}$
<i>Alnico 3</i>	25	12	—	—	—	—	7,100	12,000	475	2,000
<i>Alnico 4</i>	28	12	5	—	—	—	5,200	11,850	730	3,000
<i>Alnico 1</i>	20	12	5	—	—	—	7,100	12,350	440	2,000
<i>Alnico 2</i>	17	10	12.5	6	—	—	7,200	12,300	560	2,000
<i>Alnico 5</i>	14	8	24	3	—	—	12,000	17,200	550	3,000
<i>Alnico 12</i>	18	6	35	—	8	—	5,800	12,800	950	3,000
<i>Comol 41</i>	—	—	12	—	17	—	10,000	15,200	225	1,000
<i>Vectolite 61</i> (30% $\text{Fe}_2\text{O}_3$ -44% $\text{Fe}_3\text{O}_4$ -26% $\text{Co}_2\text{O}_3$ )	—	—	—	—	—	—	1,600	4,800	900	3,000

\*Complete information on these alloys can be secured from General Electric Company, Schenectady, N. Y.

metals.<sup>36</sup> Metallographic structures typical of the Alnico magnets in both the "as-cast" and the sintered conditions are shown in Fig. 549.

Although under some conditions satisfactory "as-cast" magnets can be produced, in general a high-temperature solution treatment followed by an air or oil quench and a low-temperature precipitation treatment is required for best magnetic quality. Very high values of  $\beta_r$  can be secured by cooling

<sup>36</sup> See G. H. Howe, Chap. 48, and P. R. Kalischer, Chap. 49, in *Powder Metallurgy*: American Society for Metals, Cleveland, Ohio, 1942.



Equivalent Permanent Magnets Of Different Alloys In Comparison With Those Of Alnico

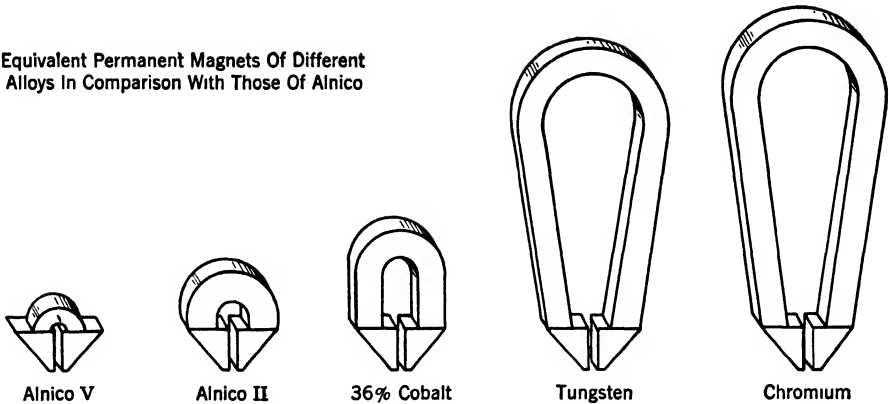


FIGURE 550. Equivalent magnets made of different kinds of magnet materials comparing Alnico magnets with those of three common magnet steels. (Courtesy General Electric Company.)

from a high temperature in a strong magnetic field. The Alnico-type magnets are less subject to demagnetization by high temperatures than other permanent-magnet alloys.

The molybdenum alloy, *Comol 41*, usually is cast to shape although it may be hot-rolled into thin sheets from which magnet shapes can be punched. After proper heat treatment it can be machined or drilled readily, and it has magnetic properties superior to those of the chromium-, tungsten-, or cobalt magnet steels. For use in high-sensitivity instruments it has an advantage over the chromium- or tungsten magnet steels because of its greater stability and, in times of emergency, requires fewer strategic metals than the 36% cobalt steels.

The *Vectolite 61* oxide magnets also are made by powder metallurgical methods and hence are limited somewhat in the sizes that can be made. These magnets are weak mechanically but have the advantages of low specific gravity, a high electrical resistivity, approximately  $225 \times 10^6$  microhm per cm cube, combined with a coercive force higher than most of the Alnico alloys. The Vectolite type of magnet has been used most, as diametrically magnetized cylinders, for rotor magnets for d-c selsyn motors, tachometer indicators, and other types of moving-magnet instruments. They frequently are magnetized at an elevated temperature, during cooling from about 930 F (500 C).

In Fig. 550 the comparative sizes of equivalent magnets made of some of the different kinds of the more common magnet materials are indicated. The superiority of the Alnico type, particularly *Alnico V*, is evident.

Still another new development is the group of alloys containing 36–62% cobalt, 6–16% vanadium, 30–52% iron which is available commercially

under the name *Vicalloy*. Maximum values of  $\beta \times H$  of  $2.8 \times 10^6$  can be secured, and values as high as  $1.0 \times 10^6$  are possible without cold-working. Coercive forces as high as 400 oersteds and values of remanence as high as 9600 gauss also can be produced. Optimum mechanical properties are produced with this alloy by casting, hot-swaging, cold-drawing with reductions in area as high as 95% and then heat-treating for 1 hr at 1110 F (600 C).

Two copper-base permanent-magnet alloys have been developed lately which contain copper, nickel, and either iron or cobalt. The first of these, nominally 60% Cu–20% Ni–20% Fe, is known commercially as *Cunife*,<sup>37</sup> and the second, nominally 50% Cu–21% Ni–29% Co, as *Cunico 21*.<sup>37</sup> Both of them are cold-workable, machinable, and susceptible to age-hardening after suitable treatment. Typical magnetic properties are:

	$\beta_r$ (GAUSS)	$\beta_{max}$	$H_c$ (OERSTEDS)	$H_{max}$
<i>Cunife</i>	5,400	8,400	550	2,400
<i>Cunico 21</i>	3,400	8,000	710	3,200

The *Cunife* magnets, which are made from wire stock, have directional properties and must be magnetized in the direction in which they were drawn. They have been used mainly in the smaller sizes, in which they are better magnetically. In small sizes the magnet wire has a strength of about 120,000 psi and an electrical conductivity of about 9.2% that of copper.

The *Cunico 21* magnets can be produced in a greater variety of forms than are at present possible with the copper-nickel-iron alloys. In the cast forms, however, full magnetic properties are not realized. This alloy also has the advantage that it can be magnetized in any direction and it is better suited for magnets in which a large cross section is needed to produce a large enough total flux. In general, it is to be preferred to *Cunife* for magnets larger in diameter than 0.250 in.

The older *Heusler alloys*, which contain about 30% manganese, varying amounts of aluminum, tin, arsenic, antimony or bismuth, small amounts of iron, silicon, and lead, and the remainder copper, are also strongly ferromagnetic but, as usually made, they are so brittle that they have not been used commercially. A somewhat similar alloy, in which silver has been substituted for copper, recently has been made available under the name *Simanal*.<sup>38</sup> Because of its composition, nominally 86.75% Ag–8.8% Mn–

<sup>37</sup> General Electric Company tradenames.

<sup>38</sup> General Electric Company tradename.

4.45% Al, and heat treatment it is, however, rather expensive. Its principal advantages are its workability and machinability although the extremely high coercive force permits it to withstand severe demagnetizing effects. This makes it particularly valuable for applications in which magnets are subject to the severe demagnetizing effects of heavy a-c fields, or used as the moving element in instruments for measuring the strengths of permanent magnets. Because of its low residual flux ( $\beta_r = 550$ ) Silmanal requires a much larger area than most other permanent magnet materials to produce the same flux. A typical shape is a thin disk magnetized across its thickness. These characteristics would enable the alloy to serve as a compass needle magnetized across the width instead of along the length as is customary. Such a magnet needle apparently would point east and west instead of the conventional north and south.

#### MAGNETICALLY-SOFT MATERIALS

The magnetically-soft alloys<sup>39</sup> must combine as many as possible of the following characteristics with a moderate cost and ease of processing:

1. A low hysteresis loss on passing through a magnetic cycle
2. A low eddy current loss
3. A high, and preferably a controllable, magnetic permeability, especially at low field strengths
4. A high saturation value
5. A definite change in permeability with temperature, especially for certain applications

Practically all the magnetically-soft alloys are ferrous. The impurities present must be kept as low as possible, especially elements like carbon, sulfur, and nitrogen which form interstitial solid solutions, and any elements which might precipitate from solid solution during aging at atmospheric temperatures. Any precipitation within the metal will result in an increase in the coercive force, sometimes amounting to as much as 100%. The magnetic properties depend on the perfection and regularity of the space lattice being maintained. For this reason also, the grain size should be kept as large as possible, in order to minimize grain boundary disturbances; and any work-hardening strains should be entirely absent.<sup>40</sup>

#### THE EPSTEIN TEST

Electrical sheet steel for magnetic core construction is sold on a basis of maximum core loss, usually guaranteed not to exceed a specified value at

<sup>39</sup> See T. D. Yensen, *Trans. A.S.M.*, 27, 1939, 797.

<sup>40</sup> See, for example, T. D. Yensen and N. A. Ziegler, *Trans. A.S.M.*, 23, 1938, 556.

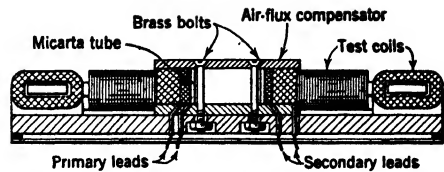
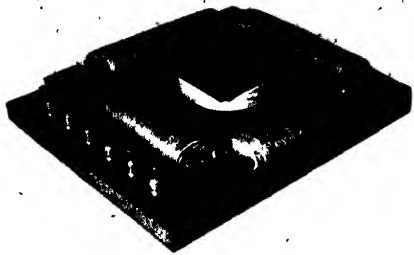


FIGURE 551a. (Left) A 25-cm Epstein frame used in Westinghouse Research Laboratories.

b. (Right) Cross-sectional view of test frame to show mounting of air-flux compensator.

10,000 gauss for a prescribed frequency. This is determined by the Epstein Test, which is described in A.S.T.M. Standard A34. The standard test measures, by means of a wattmeter, the core loss in a 10-kg (22-lb) sample made up of annealed strips 50 cm (19-11/16 in.) long by 3 cm (1-3/16 in.) wide. The strips are sheared from two or more sheets, in such a manner that one half are cut parallel and one half perpendicular to the direction of rolling.

The testing frame shown in Fig. 551 is used to test four bundles at a time, two containing parallel-cut and two containing perpendicular-cut specimens.

#### PURE IRON

Pure iron is, in many respects, the ideal ferromagnetic material except for its comparatively low electrical resistance. This makes it unsuitable for use with alternating currents, because of the necessity of restricting the eddy currents, even though the difficulty can be overcome partially by using very thin laminations for built-up cores. Very pure *carbonyl iron*, made by a process similar to the Mond process for nickel, is produced in small quantities, and electrolytic iron is commercially available in moderate amounts. The structure of the purest commercially available iron, *Puron* (formerly *Wemco*), (Fig. 552) is similar to that of the usual commercial ingot iron since oxygen is not considered as an impurity in these materials. The difference in the hysteresis loop and the  $\beta$  vs. H curves for electrolytic and for ingot iron is very marked, however (Fig. 553).

#### EFFECTS OF ALLOYING ELEMENTS

Silicon and aluminum in solid solution increase the electrical resistance of pure iron more than any other substitutional alloying elements. Both elements also tend to eliminate the allotropic modifications (the gamma

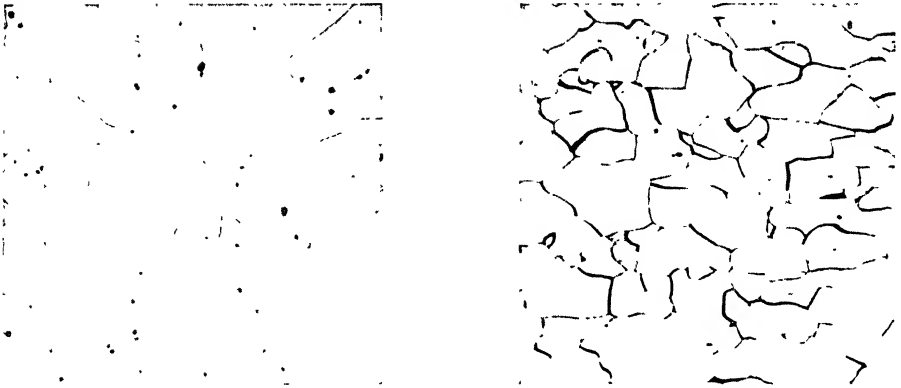


FIGURE 552a. (Left) Metallographic structure of high-purity iron (Puron). Etched with picral.  $\times 100$ . (Photomicrograph courtesy Research Laboratory, Westinghouse Electric Corp.) Oxygen is not considered as an impurity in this material.  
 b. (Right) Metallographic structure of sheet steel that has been decarburized drastically by annealing in moist hydrogen. Etched with nital.  $\times 250$ . (Photomicrograph courtesy Research Laboratory, General Electric Company.) Both photomicrographs reduced about one half in reproduction.

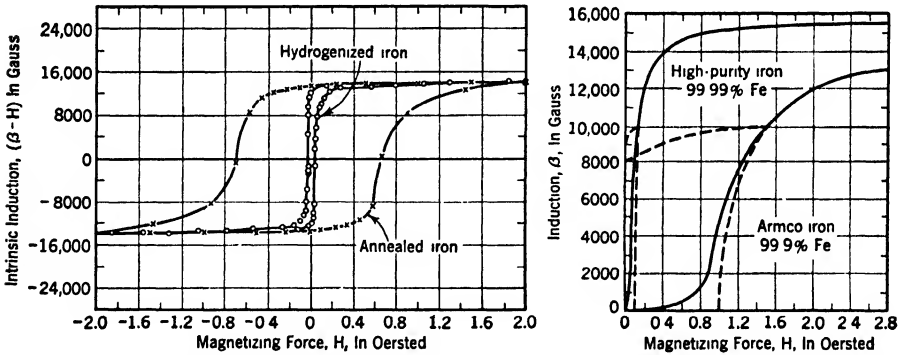


FIGURE 553a. (Left) Hysteresis loops for annealed ingot iron and for hydrogenized iron. (After P. P. Cioffi.)  
 b. (Right) Magnetization curves for ingot iron and for high-purity iron. (After T. D. Yensen.)

loop closes at about 2.2% silicon or about 1% aluminum), and thus permit higher annealing temperatures for the purpose of securing larger grains. Silicon, in particular, also markedly promotes grain growth in ferrite. However, 4.5% silicon or 8% aluminum is the maximum that can be added without the iron becoming too brittle for commercial use.

SILICON TRANSFORMER SHEETS

The silicon transformer alloys, sometimes called *Hadfield electrical steel* after Sir Robert Hadfield, their original discoverer,<sup>41</sup> usually are made in

<sup>41</sup> See also *The Alloys of Iron and Silicon*, by E. S. Greiner, J. S. Marsh, and B. Stoughton: McGraw-Hill Book Company, Inc., New York, 1933, Chaps. 14 and 15.

basic open-hearth or electric furnaces and hot-rolled to their final dimensions. A typical transformer steel will analyze:

% SI	% MN	% P	% S	% C
4.5-5.0	0.10 (max)	0.02 (max)	0.02 (max)	0.05 (max)

However, depending upon the application, the silicon content may vary appreciably. The usual grades with their uses are shown in Table LV.

TABLE LV GRADES OF SILICON TRANSFORMER STEEL

GRADE	% SI	USES
Armature	0.5	Generators and small motors
Electrical	1.0	Generators and small motors
Motor	2.5-3	Induction motors
Transformer I	3.25-4	Generators and low-frequency transformers
Transformer II	4-5	60-cycle transformers

The principal mechanical requirement is that the sheets shear or punch without formation of ragged edges. Heating to about 200 F (95 C) improves the ductility noticeably.

The sheets are annealed in the range 1475-1650 F (800-900 C) to secure the largest possible grain size. This should be done in a nonoxidizing atmosphere for best results, and sometimes box annealing is used.<sup>42</sup> The rate of cooling is not important so long as the sheets remain flat, and, in the lower silicon alloys, any carbon has an opportunity to precipitate as graphite. Metallographic structures of typical alloys after various treatments are shown in Fig. 554. Note the freedom from oxide inclusions indicative of the deoxidizing effect of the silicon.

By producing a particular type of crystal orientation in silicon transformer steel, the steel can be magnetized more easily in certain directions and its flux-carrying capacity increased by more than 30% with no increase in the magnetizing force or the core loss.<sup>43</sup> A commercial steel of this type,

<sup>42</sup> See, for example, T. D. Yensen and N. A. Ziegler, *Trans. A.S.M.*, **24**, 1936, 337.

<sup>43</sup> See, for further information, J. K. Hodnette and C. C. Horstman, *Westinghouse Engineer*, **1**, August 1941, 52-56.

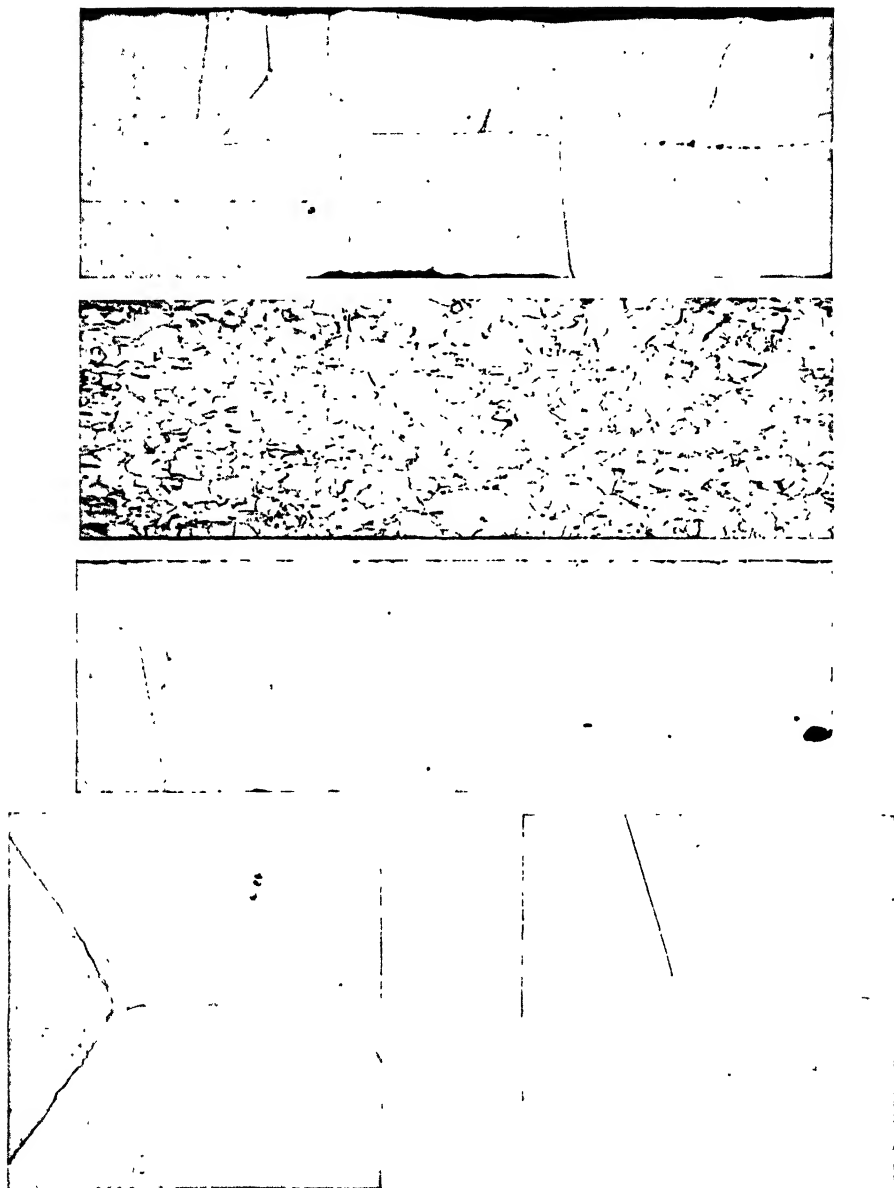


FIGURE 554. Metallographic structures of silicon-iron transformer sheet. Full cross sections.

*a.* (Top) Hot-rolled. Etched with picral.  $\times 100$ . Note that the grains, possibly because of the stress distribution, occupy only about one half of the cross section of the sheet.

*b.* (Second row) Cold-rolled. Etched with picral.  $\times 100$ . The grains either were comparatively small before rolling or else have been fragmented greatly during rolling.

*Hypersil*, is said to have reduced the size and weight of distribution transformers as much as 25%, thus enabling a 10% reduction in copper losses with increased short-time overload capacity.

#### ALUMINUM-IRON TRANSFORMER ALLOYS

The aluminum-iron and aluminum-silicon-iron alloys thus far have been so difficult to manufacture satisfactorily that they have had little commercial development even though they compare favorably with the straight silicon materials.

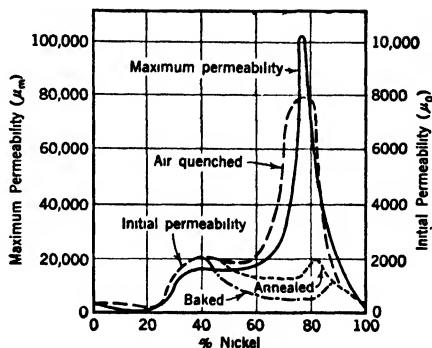


FIGURE 555. Maximum and initial permeabilities for the iron-nickel series, illustrating the influence of various heat-treatments. (After G. W. Elmen.)

#### IRON-NICKEL ALLOYS

The annealed iron-nickel alloys have *permeabilities* similar to those of the best grades of iron and the iron-silicon alloys. Alloys containing more than 50% nickel, however, are sensitive to heat-treatment, as illustrated in Fig. 555. In general, there are four different classes of these alloys, depending upon the relationship between the permeability and the other electrical and magnetic characteristics.

#### ALLOYS WITH HIGH PERMEABILITY AT LOW FIELD STRENGTHS

These alloys are used principally when very high impedance characteristics are required at flux densities ( $\beta_{\max}$ ) less than 1 gauss. In this group are:

*c. (Third row)* Annealed at elevated temperatures. Etched with picral.  $\times 100$ . Note that the individual grains now occupy the entire cross section of the sheet.

*d. (Bottom left)* Iron carbide at grain boundaries of annealed 3.5% silicon-steel transformer strip indicative of presence of carbon. Etched with nital.  $\times 500$ .

*e. (Bottom right)* Typical as-cast structure of vacuum melted ingot of high-purity iron containing 3.3% silicon. Etched with nital.  $\times 600$ . Note the clear grain boundaries.

(Photomicrographs *a, b, c* courtesy Research Laboratory, Westinghouse Electric Corp.; *d, e* courtesy Research Laboratory, General Electric Company; reduced about one half in reproduction.)



	% NI	% CR	% MO	% CU	% FE
<i>Permalloy</i>	30-90	0-4	0-4	—	Rem.
<i>Mumetal</i>	76	1.5	—	6	Rem.

In the alloyed Permalloys,<sup>44</sup> containing either chromium or molybdenum, air-quenching is not required to develop maximum permeabilities. Some of the magnetic properties of these alloys in comparison with the pure irons are given in Table LVI.

TABLE LVI MAGNETIC PROPERTIES OF SOME ALLOYED PERMALLOYS

	PERMEABILITY		SATURATION VALUE (GAUSS)	RESISTIVITY (MICROHM- CM)
	INITIAL	MAXIMUM		
99.95% ( <i>Puron</i> ) iron	—	100,000	21,600	10
<i>Armco</i> iron	250	7,000	22,000	11
4-4.5% Silicon iron	500	12,000	19,500	55
45% Ni-55% Fe <i>Permalloy</i>	2,700	23,000	16,000	45
78.5% Ni-21.5% Fe <i>Permalloy</i> , quenched	10,000	105,000	10,700	16
78.5% Ni-3.8% Cr-17.7% Fe <i>Permalloy</i>	12,000	62,000	8,000	65
78.5% Ni-3.8% Mo-17.7% Fe <i>Permalloy</i>	20,000	75,000	8,500	55
<i>Mumetal</i> *	30,000	100,000	6,500	

\* Annealed in a continuous stream of pure dry hydrogen at 2000 F (1100 C).

#### ALLOYS WITH HIGH PERMEABILITY FOR HIGHER FIELD STRENGTHS

These alloys almost all contain about equal parts of nickel and iron (50:50), and are marketed in this country under the names of *Hipernik*, *Nicaloi*, *Audiolloy*, and *Allegheny Electric Metal*. The alloy 50:50 *Permendur* (50% Fe-50% Co) is also available commercially. They are most useful for high-impedance designs carrying only alternating currents. For best results they should be annealed thoroughly for several hours at 1830-2200 F (1000-1200 C) in dry hydrogen, after all fabricating operations have

<sup>44</sup> See G. W. Elmen, 1936 Convention A.I.E.E.

been completed. The alloys of this class will have an initial permeability of 4500–5000, a maximum permeability which may vary between 3200 and 100,000 depending on the specific composition, purity, and treatment, a saturation value of 16,000 gauss, which is the highest of all iron-nickel alloys containing more than 30% nickel, and a resistivity of 45 microhm-cm.

Although alloys of this type could replace the 4% silicon iron for transformer cores very efficiently, their high cost limits them to special transformers, such as current transformers. For many applications the high saturation value is a distinct advantage, even though the initial permeability is quite low.

#### ALLOYS WITH A CONSTANT PERMEABILITY OVER A RANGE OF FLUX DENSITIES

The *Perminvar* alloys containing about 45% Ni–25% Co–30% Fe, and the alloy *Conpernik*, which contains 50% Ni–50% Fe and is so heat-treated below 1475 F (800 C) as to anneal it incompletely, have a constant permeability at low magnetizing forces. These materials are useful wherever a constant inductance or reactance is essential, as in filter coils for radio circuits or loading coils for telephone circuits.

#### ALLOYS WITH PERMEABILITIES VARYING WITH TEMPERATURE

Alloys for magnetic temperature compensation generally contain about 30% nickel, with the remainder iron, except possibly for small additions of manganese, chromium, and silicon. Two common ones are *Compensator Alloy* and *N30*. For all values of  $H$  up to 1000 a nearly linear relationship exists between  $\beta$  and the temperature, within the range of  $-4$  to  $+140$  F ( $-25$  to  $+60$  C).

Also used for this purpose are the alloys *Calmalloy* (69% Ni–29% Cu–2% Fe) and *Westinghouse Alloy* (70% Ni–29% Cu–1% Mn–5% Si (max)) for which the  $\beta$  vs. temperature relationship is not so linear as it is for the other two.

These alloys are used because the magnetic permeability of iron and its alloys generally decreases with temperature. This creates an error in the readings of electrical meters, such as watt-hour meters, which depend upon the flux produced by a constant voltage supply or a definite load current. To compensate for this error, a certain amount of the magnetic flux is shunted around the moving part of the meter by means of an alloy having a high magnetic temperature coefficient between 30 and 210 F (0 and 100

C). Thus, as the surrounding temperature increases, the amount of the shunted flux decreases, forcing more of the flux through the moving member than otherwise would be the case. By proper proportioning it is possible, therefore, to compensate nearly completely for the temperature changes. In the automotive speedometer, compensation of a permanent magnet also is used, just as in the watt-hour meter, to maintain accuracy regardless of temperature.

In electromagnets, too, the temperature of the magnet winding fluctuates with changes in the surrounding temperature. As the temperature increases, therefore, the copper resistance increases and the current through the winding decreases. Since the field strength depends upon this current, the field also must weaken as the temperature increases. This weakening of the field can be overcome by proper use of a compensating shunt which usually is attached to the core of the magnet. This type of compensation is important in voltage regulators.

#### *For Further Study Refer to*

1. *Book of Stainless Steels*, 2d ed., edited by E. E. Thum: American Society for Metals, Cleveland, Ohio, 1935.
2. *Metals Handbook*: American Society for Metals, Cleveland, Ohio, 1939 (usually published triennially). A new edition will appear in 1948.
3. *Magnetic Core Materials Practice*: Allegheny Steel Co., Brackenridge, Pa., 1937.
4. *Steel Cored Copper Conductors*: Copper Development Assoc., London.
5. *Cadmium Copper Conductors*: Copper Development Assoc., London.
6. *Copper for Bus Bars*: Copper Development Assoc., London.
7. *Tin Solders*, 2d ed., by S. J. Nightingale and O. F. Hudson: British Non-Ferrous Metals Research Assoc., London, 1942.
8. *Powder Metallurgy*, edited by John Wulff: American Society for Metals, Cleveland, Ohio, 1942.
9. *Metal Progress*: American Society for Metals, Cleveland, Ohio (published monthly).
10. *Materials and Methods* (formerly *Metals and Alloys*): Reinhold Publishing Corporation, New York (published monthly).
11. Publications of:
  - Allegheny-Ludlum Steel Corp., Brackenridge, Pa.
  - Aluminum Co. of America, Pittsburgh, Pa.
  - American Brass Co., Waterbury, Conn.
  - American Rolling Mill Co., Middletown, Ohio.

Anaconda Wire and Cable Co., New York, N. Y.  
Bell Telephone Laboratories, New York, N. Y.  
Bridgeport Brass Co., Bridgeport, Conn.  
Carpenter Steel Co., Reading, Pa.  
Cerro de Pasco Copper Corp., New York, N. Y.  
Chase Brass & Copper Co., Waterbury, Conn.  
Driver-Harris Co., Harrison, N. J.  
Wilbur B. Driver Co., Newark, N. J.  
General Alloys Co., Boston, Mass.  
General Electric Co., Schenectady, N. Y.  
Handy & Harman Co., New York, N. Y.  
Hevi-Duty Electric Co., Milwaukee, Wis.  
Hoskins Mfg. Co., Detroit, Mich.  
International Nickel Co., Inc., New York, N. Y.  
C. O. Jelliff Mfg. Co., Southport, Conn.  
Permanente Metals Co., Oakland, Cal.  
Reynolds Metals Co., Louisville, Ky.  
Simonds Saw & Steel Co., Lockport, N. Y.  
Titan Metal Co., Bellefonte, Pa.  
U.S. Steel Corporation, New York, N. Y.  
Western Electric Co., Chicago, Ill.  
Westinghouse Electric Corp., East Pittsburgh, Pa.



# Index

- Abnormal grain growth, 97
  - steels, 739
- Abrasion-resistant alloys, 731–759
- Acid, 9
  - Bessemer process, 191–197; tonnage produced since 1925, 182
  - corrosion, 485
  - electric process for steel, 212
  - open hearth process for steel, 205–207; tonnage produced since 1925, 182
  - oxides, 110
- Acorn Brand*, 811
- Admiralty gun metal, 588, 822
- Admiralty metal, 579
  - sulfur corrosion, 490
  - impingement attack, 491
  - plug-type dezincification, 492
- Adnic*, 583
- Advance*, 843
- Age-hardening (see precipitation-hardening)
- Aging
  - in mild steel sheet, 346, 532
  - Invar for stability, 854
- Agitation, effect on corrosion, 489
- Air furnace melting of cast iron, 176
- Ajax-Northrup furnace, 120
- Ajax* steel, 780
- Ajax-Tama-Wyatt furnace, 117–119
- Ajax-Wyatt furnace, 117–118
- Albany* steel, 775
- Alclad*, 704
- Alcoa direct casting process, 404
- Alco* steel, 779
- Alcres*, 847
- Alcrosil* steel, 603
- Aldrey*, 838
- Al-fin* bearing, 818
- Alidie* steel, 777
- Allegheny 12* steel, 605
  - 12 EZ*, 605
  - L-12*, 607
  - 17*, 608
  - H-17*, 608
  - M-17*, 608
  - Metal 18-8*, 616
  - 21*, 611
  - 28*, 612
  - 46*, 603
  - Electric Metal*, 882
- Allotriomorphic grains, 68
- Allotropic recrystallization, 101–102
- Allotropy, 99–100
- Alloy cast iron, 178
  - corrosion-resistant, 627
  - heat-resistant, 631
  - high-strength, 697
  - low expansion, 854
  - tools, 795
  - wear-resistant, 751
- Alloyed *Permalloys*, 882
- Alloying, 263
  - by powder metallurgy, 263–265
  - effect on tool steel, 761
  - elements, effects on hardenability, 387
- Alloys, 4
  - bearing, 801
  - carburizing, 682
  - chemical corrosion-resistant, 593
  - controlled expansion, 855
  - constructional, 664
  - electrical conducting, 833
  - electrical resistance, 841
  - for formability, 525

- Alloys (*cont'd*), fusible, 858  
 hardware, 556  
 heat-resistant, 593  
 high-strength, 664  
 magnetic, 870  
 tool, 760  
 water corrosion-resistant, 572  
 wear-resistant, 731
- Alnic*, 872  
*Alnico*, 873  
 Alpha brasses, 540  
*Alumel*, 851  
 Alumilite process, 521  
 Aluminum, 136–143  
 ores, 136, 139  
 Hall-Heroult process, 137  
 Ancor process, 139, 142  
 Bayer process, 136  
 commercial specifications for, 139, 140  
 electrical conductors, 833, 837  
 Hoopes refining process, 139  
 in steelmaking, 194, 213, 219  
 Kalunite process, 139–142  
 ores, 136, 139  
 protective coatings; Alclad, 517;  
 Alumilite, 521; Calorized, 514;  
 Eloxal, 521
- Aluminum alloys  
*Alcoa* 2S, 546  
 3S, 475, 546  
 11S, 475, 560  
 13, 564  
 14S, 708  
 17S, 560, 703  
 A17S, 703  
 18S, 660  
 24S, 560, 665, 703  
 25S, 708  
 32S, 660  
 43, 564, 589, 711  
 45, 711  
 47, 711  
 A51S, 708  
 52S, 546  
 53S, 549  
 61S, 549  
 75S, 665, 707  
 81, 564  
 85, 564  
 112, 709  
 122, 657  
 A132, 657
- Aluminum alloys (*cont'd*)  
*Alcoa* 142, 657  
 196, 709  
 212, 709  
 214, 589  
 218, 564  
 220, 589, 710  
 355, 661  
 A355, 661  
 356, 589, 711  
 360, 564  
 380, 564  
 750, 817  
 bearing, 817  
 casting, 589  
 -copper, 340, 342, 344, 347  
 die casting, 563  
 free-machining, 560  
*Hiduminium R.R.* 77, 665, 705  
 piston, 656  
 powdered metal bearing, 818  
 -silicon, 712  
 steel-backed bearing, 818  
 temper designations, 547, 550
- Aluminum brass, 580  
 corrosion by pitting, 489  
 bronze, 583  
 ball bearings, 757  
 wear resistance, 757  
 nonsparking tools, 797
- Alva Extra* steel, 770  
*Special* steel, 770
- Amalgams, dental, 865  
*Amaloy*, 503  
 Ambassador Bridge failure, 672  
*Ambrac*, 583  
 Amorphous metal hypothesis, 87  
*Ampco metal*, 758
- Analyses typical of acid open hearth steels,  
 207  
 basic open hearth steels, 207  
 Bessemer steel, 197  
 ingot iron, 209  
 pig irons, 158  
 wrought irons, 190
- Ancor process for metal grade alumina,  
 139, 142
- Anhydrous magnesium chloride, 126–127
- Annealing, 336–337, 371–375  
 twins, 83, 84, 86
- “A” Nickel, 633
- Anode slimes in copper refining, 239
- Anodic cleaning, 371

- Anti-Friction Alloy*, 828
- Antimonial lead, 655
- Arc-cutting, 472, 479
- Arco 13* steel, 605
- Arc welding, 465–469
  - furnace, 113–115
- Armco 17* steel, 608
  - 18–8, 616
  - 27, 612
  - High Tensile*, 670
  - iron, 526, 878, 882
- Arrow steel, 775
- Arsenical copper, 240, 577, 833
- Art Die* steel, 775
- A. S. & R. direct casting process, 406
- Asarco-Lov*, 813
- A.S.M.E. Boiler code, 471
- Atha Pneu* steel, 779
  - Rim Roll* steel, 775
- Atlas A* and *B* steels, 781
- Atomic-hydrogen welding, 465
  - number, 3
- Atomized powder, 448
- Audiolloy*, 882
- Aurora Babbitt*, 828
- Austempering, 350, 374
  - properties resulting from, vs. quench-and-temper method, 355
- Austenite, 306
  - effect of alloying elements on transformation, 366, 367
  - effect of cooling rate on transformation, 357–359
  - grain size, 73; delineated by nodular pearlite, 364; effect on machinability, 476; effect on transformation rate, 363
  - isothermal subcritical transformation, 349, 350
  - microstructure typical of, 307
- Austenitic cast iron, 628
  - manganese steel, 747; alloyed, 748; nickel, 748
  - steels, 325, 367, 613, 674–679, 746; microstructure showing precipitated carbides, 345
  - 18:8 stainless steels, 613
- Autofretage, 337
- Automatic arc welding, 468
- Automotive gray cast iron, 697
- Automotive steels, 679
  - alloy carburizing grades, 682
  - carburizing grades, 681
- Automotive steels, forging grades, 685
  - heat treating grades, 685
  - mechanical properties of heat-treated, 687
  - N.E. steels, 688
  - spring steels, 687
- Auxiliary metals, 5, 7
- Average useful life of resistance alloys, 842
- A. W. Dyn-El* steel, 670
- Babbitts, 808–811
- Bahnmetall*, 827
- Bainite, 350–355
  - decomposition during tempering, 361
  - properties, 357
- Ball bearings, 756
- B. & W. 400, 401*, and *402* steel, 603
  - #1100, 1101, and 1102, 625
  - #1300, 625
- Barrel plating, 508
- Base, 9
- Basaloy*, 865
- Base metal couples, 851
- Basic Bessemer process for steel, 198
  - electric process for steel, 210, 211
  - open hearth process for steel, 198–208; tonnage produced since 1925, 182
  - oxides, 110
  - pig iron, 158
- Bauxite, 136
- Bayer process for metal grade alumina, 136
- Bearing bronzes, 818–825
- Bearing metals, 801–831
- Bearite*, 827
- Bearium*, 823
- Belgian rolling mill, 423
- Bell welding, 429
- Belmalloy*, 702
- Benefication, 108
- Berylco 25S*, 726
  - 165S, 728
- Bermox*, 828
- Beryllium-aluminum alloys, 665
  - bronze, 726, 797
- Bessemer iron ores, 164
  - pig iron, 158
  - process for steelmaking, 198
- Bethadur 302* steel, 616
  - 310, 625
  - 403, 605
  - 410, 605
  - 420, 607



- Bethadur* 430, 608  
 440, 607  
 442, 611  
 446, 612  
 501, 603  
 502, 603  
*Bethalon* 416 steel, 605  
*Beth-Cu-Loy* steel, 528  
*Bethlehem Best* steel, 770  
     *Superior*, 770  
     *X, XX, XXX*, 769  
 Betts electrolytic process for lead, 255  
 Big-end-down ingots, 215–216  
     -up ingots, 215–216  
 Billet mills, 422  
 Bismuth solder, 864  
 Black copper, 231  
     martensite, 364  
     oxide coatings, 522  
     slag, 211  
 Blast furnace, 112  
     copper, 231  
     iron, 159–167  
     lead, 251  
     tin, 257  
     roasting, 231  
 Blister copper, 234  
 Blooming mill, 422  
 Blowholes, 217, 223, 224  
 Blue brittle range in steel, 420  
*Blue Chip* steel, 784  
*Blue Grass High Speed*, 827  
 Blue powder, 146  
 Body-centered cubic space lattice, 76  
 Boiler plate, 572  
 Boiler safety plugs, 864  
*Bolt Die Regular* steel, 780  
*Bonded Carbide* steel, 789  
 Bonderizing, 522  
 Bottle-top ingots, 215  
 Bottom-poured ingots, 215  
*Boveall Babbitt*, 812  
 Box carburizing, 735  
*Brastil*, 568  
 Brass pipe, 576  
 Brasses for free-machining, 558  
 Brazing, 452  
     alloys, 866–868  
 Bridge cable, 672  
 Bright annealing, 375  
 Brinell hardness test, 22  
 Brine quenching, 379  
*Britannia* metal, 570  
*British Navy Antifriction Metal*, 811  
 Bronze, 720  
     aluminum, 583  
     bearing backings, 804  
     beryllium, 726, 797  
     brazing, 452  
     copper-lead, 822  
     copper-tin-lead, 821  
     copper-tin-zinc, 822  
     graphite, 824  
     nickel-antimony-lead, 821  
     nickel, castings, 723  
     welding, 870  
 Bushings, 803, 806, 824  
     porous, powder metallurgical, 264  
*Buster* steel, 779  
 Butt welding, 459  
 Byers-Aston process for wrought iron,  
     182, 189  
*B-4* steel, 781  
*B-7* steel, 789  
*B-8* steel, 790  
*B-9* steel, 785  
 Cable sheathing, extrusion of, 416  
 Cable, bridge, 672  
 Cadmium alloys, 812  
     cadmium-nickel bearing, 813–814  
     cadmium-silver bearing, 814–815  
     cadmium-silver-copper bearing, 814–  
         815  
     solder, 862  
 Calcium lead, 655  
*Calite A*, 625  
     *N2*, 626  
*Calloys*, 828  
*Calmalloy*, 883  
*Calo Ferro* steel, 781  
 Calomel brass, 514  
 Calorized coatings, 514  
 Camber, in rolling steel rails, 744  
 Capped steel, 222  
*Carboloy*, 791  
 Carbon-arc welding, 466  
     -free nickel, 635  
     -molybdenum steel, 599  
     segregation in steel ingots, 217, 218,  
         223  
     -silicon carbide couple, 851  
     steel, blue brittle range, 420; castings,  
         691; constitution, 305–320; for  
         formability, 529–536; heat treat-  
         ment, 348–366; manufacture, 190–

- Carbon steel (*cont'd*)  
 225; pipe, 575, 598; rails, 743;  
 structural, 667; tool, 769
- Carborundum heating elements, 848
- Carbonyl iron, 877
- Carburizing steels, 681–683
- Carmet*, 791
- Caroga* steel, 775
- Carpenter Moly* steel, 786  
 #1 steel, 605  
 #2, 607  
 #2-B, 608  
 #3, 611  
 #4, 616  
 #5, 605  
 #6, 608  
 #6-20, 611  
 #7 and #7-Mo, 613
- Carpenter tapered hardenability test bar,  
 385, 386  
 impact test, 28, 29
- Cartridge brass, 71, 540  
 hot working, 419  
 operations in fabrication of 90-mm  
 shells, 443  
 structure after cold rolling, 541
- Case carburizing, 684, 734  
 heat-treatment following, 738
- Casting, 390–407; vs. ingot, 391  
 alloys, aluminum, 564, 656–661, 708–  
 714; copper, 223, 586–589; heat-  
 and corrosion-resisting, 623–632;  
 iron, 575, 696–703, 749–756;  
 high-strength, 717; magnesium,  
 nickel, 633, 638, 643; steel, 691–  
 696; water corrosion-resistant,  
 586–591; zinc, 560
- Cast Ilium G, 649  
*Inconel*, 644  
 iron, 169–178, 665, 696–702; alloy,  
 178, 751; austenitic, 628; automo-  
 tive gray, 697; chill, 171, 751; cor-  
 rosion-resistant, 627; dies, 795; ef-  
 fect of silicon, 173; effect of nickel,  
 173; gray, 169, 696, 749; growth,  
 631; hardening, 698; heat-resistant,  
 631; heat-treated, 698; high-  
 strength, 697; high-silicon, 627;  
 high-test, 697; inoculation, 172;  
*Invar*, 854; malleable, 177, 699;  
 martensitic malleable, 702; *Mee-*  
*hanite*, 699; melting of, 173–176;  
 mottled, 171; pearlitic malleable,
- Cast iron (*cont'd*)  
 701; soil and drain pipe, 576; step-  
 bar test, 172; superheating, 172;  
 transverse flexure test, 172; wear-  
 resistant, 749; white, 170, 701, 750  
 manganese bronze, 724  
 Monel, 643  
 piston alloys, aluminum, 657  
 red brass, 586  
 -shell process, 437  
 steels, 691; carbon-steel, 691; harden-  
 able-type stainless, 608; heat treat-  
 ment, 691; low-alloy, 693; medi-  
 um-manganese, 695; molybdenum,  
 696; molybdenum-vanadium, 696;  
 nickel, 694; 4–6% chromium, 601;  
 yellow brass, 588
- Causal metal*, 628
- Caustic embrittlement of boilers, 573
- CCA steel, 777
- Cementation, 180, 734
- Cemented coatings, 513–515  
 carbon, 734
- Cementite, 306  
 atom arrangement, 272; spheroidized  
 (see spheroidite); in cast iron, 169
- Centaur* steel, 769
- Central High Tensile* steel, 670
- Centrifugal casting, 402
- Cerrobase*, 865
- Cerrobend*, 865
- Cerrolow*, 858
- Cerromatrix*, 865
- Cerroseal*, 858
- C. F. S. (Die Steel)*, 775
- Chace* 720, 729
- Chamet Bronze*, 581
- Champion Extra* steel, 773  
*Non-Changeable* steel, 776
- Channeller* steel, 769
- Chapmanizing, 735
- Charpy impact test, 27, 28
- Checking in steel ingots, 224
- Chemical activity, 11–17  
 corrosion, 486  
 lead, 653  
 properties, 9–15
- Chill casting, 399  
 cast iron, 171, 751
- Chippaway* steel, 769
- Chips in machining, 473
- Chisel and punch tools, silicon-man-  
 ganese, 773

- Chisel and punch tools, tungsten-alloy, 779  
*Chisel steel*, 779  
*Choice steel*, 780  
*Chromax*, 625  
*Chromel A*, 844  
   *C*, 846  
   *P*, 851  
 Chromium coatings, electroplated, 510, 511, 742; chromized, 515  
 die steels for hot work, 779  
 high-, high-carbon die steels, 777  
 irons, 25–30%, 611  
 -nickel-iron alloys 29:9, 623; 25:20, 625; 15:35, 625  
 -nickel-molybdenum type stainless steel, 622  
 plate, hard, for wear resistance, 742; hard, matte for bearing surface, 742  
 structural steel, 669  
 tool steels, 775  
 -tungsten die steels for hot work, 783  
*Chromoco steel*, 777  
*Cimet*, 612  
*Circle C steel*, 790  
*Clarite High Speed steel*, 784  
 Clean steel, 205, 206, 224  
 Cleavage in steel ingots, 224  
 Close-packed directions, 79, 80  
   hexagonal space lattice, 78  
   planes, 79  
 Cluster mill, 424  
*C. N. S. steel*, 777  
 Coarse grain, 95, 96  
 Coarsening temperature, 95  
 Cobalt-chromium-tungsten alloys, 793  
 Cobalt high-speed steel, 789  
*Cobalt steel*, 789  
*CoCo Turning steel*, 789  
 Coercive force, 56, 871  
 Cogging, 422  
 Coiling of sheet, 442  
 Coining, 440, 443  
 Cold chamber die casting process, 408  
   -forming, 440  
   cutting and forming, tools for, 769–775  
   iron in blast furnace, 165  
   -treatment tool steels, 764; high-speed steel, 788  
   work, 87–90, 419  
*Colonial No. 3 steel*, 781  
   *No. 6*, 776  
   *Colonial No. 14*, 769  
   *No. 35*, 780  
 Color, 55  
   scale of temperature, 48  
*Columbia Double Special steel*, 773  
   *Standard*, 770  
   *Standard Vanadium*, 770  
 Columbium-bearing 18:8, 619  
 Combination mill, 423  
*Comet steel*, 769  
*Commercial bronze*, 540  
   *G bronze*, 588, 822  
 Commercial heat treatments, 371–375  
 Commercial grades, aluminum, 240  
   copper, 240  
   lead, 256  
   magnesium, 135  
   nickel, 247  
   pig iron, 158  
   tin, 260  
   zinc, 260  
 Commercially pure metal, 268, 270  
 Commercial red brass, 587  
 Common high brass, 540  
*Comokut High Speed steel*, 789  
*Comol 41*, 873  
 Compacting metal powders, 450  
*Compensator Alloy*, 883  
*Compo*, 824  
 Components, 263  
*Composition brass*, 586  
*Composition G Bronze*, 588, 822  
   *M (leaded) bronze*, 588, 822  
 Composition rule for binary constitutional diagrams, 279  
 Compression test, 34  
 Concentration cells, 17  
 Condensed powder, 448  
 Condenser tubes, 490–494  
 Conductivity, 44–46  
   alloys, electrical, 833  
   bronze, 839  
*Conpernik*, 883  
 Conservation chart of aluminum die casting alloys, 564  
*Constant steel*, 776  
*Constantan*, 851  
 Constituents, 291  
 Constitutional diagrams  
   Al–Cu, 340; Al–Si, 712; Ag–Cu, 284; Ag–Cu–Zn, 866; Be–Cu, 341; commercially pure metal, 271; complete liquid solubility and com-

Constitutional diagrams (*cont'd*)

plete solid solubility, 277; complete liquid solubility, partial solid solubility, 283–285; composition rule, 279; Cu–Mg, 294; Cu–Ni, 277; Cu–Sn, 298; Cu–Zn, 297; Fe–C, 305, 312, 329, 341; Fe–Ce, 321; Fe–Cu, 321; Fe–Mo, 321; Fe–Ni, 321; for alloys susceptible to precipitation hardening, 339; for 18:8 stainless steels, effect of carbon, 614; intermetallic compound, 274; lever rule, 280; limitations in use of, 333; liquidus line, 278; mechanical mixtures, 275; Mg–Pb, 293; peritectic, 294; primary or terminal solid solution, 271; retrograde solubility, 286; Sb–Sn, 295; secondary or intermediate solid solution, 274; simple eutectic, 289; Sn–Zn, 289; solidus line, 278; solvus line, 286, 614; with one intermetallic compound, 293; with two intermetallic compounds, 294; 1:2:1 rule, 290, 291

## Constructional steels, 667

structural changes during cooling, 311–315

## Continuous casting, 403–407

machining chips, 473  
mill, 422  
rails, 745

## Controlled-expansion aluminum pistons, 661

## Controlled steel

basic open hearth, 198; Bessemer, 196, 197

## Converters

copper, Great-Falls-type, 233, 234  
copper, Peirce-Smith-type, 233, 234  
nickel, Peirce-Smith-type, 243  
iron, Bessemer, 189, 191–194

## Cooling curves, 65, 66

*Copel*, 843

## Copper, 227, 475, 538

blast furnace smelting, 231  
blister, 234  
brazing, 869  
cathodes, 237, 239  
-clad steel, 519  
converting, 233, 234  
electrical conductors, 833  
electrolytic refining, 236, 237

Copper (*cont'd*)

fire refining, 234  
free-machining, 559  
high purity, 241  
hydrometallurgy, 239  
impurities in fire refined, 235  
industrial shapes, 235, 236  
lake, 235  
minerals, 228  
O.F.H.C., 240, 241  
ores, 227, 228  
oxygen-free, 240, 241  
phosphorus deoxidized, 241  
pipe, 576  
poling, 234  
protective tariff, 229  
pyrometallurgical extraction, 229  
reverberatory furnace smelting, 232  
roasting, 229  
tough-pitch, 234  
water tubing, 577  
-weld steel, 519

## Copper alloys

-aluminum, 340, 585 (see also aluminum bronzes)  
bearing bronzes, 818–825  
beryllium-, 341, 346, 726 (see also beryllium bronzes)  
brazing alloys, 866–870  
cast, structures, 202–203  
conductivity bronze, 839  
die casting, 567  
free-machining, 558  
graphite bronze, 824  
-lead bronze, 822  
leaded nickel-bronze, 724  
magnet alloys, 875  
manganese bronze, 724  
-manganese-nickel, 728  
-nickel, 277  
nickel-antimony-lead bronze, 821  
nickel bronze, 723  
-nickel-zinc, 544, 568  
phosphor bronze, 720  
resistance alloys, 824  
sheet, 538–546  
silicon bronze, 718  
-silver, 284–288  
-tin, 298–299, 301–304  
tin bronze, 720  
-tin-lead bronze, 821  
-tin-zinc bronze, 822  
-zinc, 297; cartridge brass, 304, 336;

- Copper alloys (*cont'd*)  
 cast structures, 302, 303; change of color with composition, 301; constitutional diagram, 297, 299; die castings, 568; effect of heat-treatment on structure of 58% Cu-42% Zn alloy, 300; Muntz metal microstructure, 304; properties, 542; properties vs. composition, 299
- Copper-bearing iron and steel, 528
- Copper coatings  
 as a stop-off for carburizing, 737  
 copper-clad, 519  
 copper-weld, 518  
 electroplated, 509  
 patina, 519, 520
- Copper Ingot Iron*, 528
- Cop-R-Loy* iron, 528
- Coreless induction furnace, 120
- Core loss test, 876
- Coring in foundry practice, 392  
 from nonequilibrium solidification, 280, 281, 282  
 microstructures of cast brasses and bronzes, 303
- Corroding lead, 254
- Corrosion coatings, 513
- Corrosion, 15-17, 484-496, 627  
 fatigue, 494  
 of boiler plate, 573  
 of condenser tubes, 490  
 -resistant cast iron, 627  
 testing, 494, 495
- Corrugation for stiffening, 525
- Cor-Ten* steel, 670
- Coslettizing, 521
- Cottrell precipitators, for copper dust, 232  
 for lead, 256
- Cracks in steel ingots, 224
- Crankcase alloys, cast aluminum, 660
- Creep, 35-36, 593-598  
 stainless steels, 610  
*K42B*, 610  
 29:9 alloys, 624  
 35:15 alloys, 624
- Creepage in railroad rails, 745
- Crescent Double Special* steel, 773  
*Hot Work No. 2*, 780  
*Rim Roll*, 775  
*Special Alloy Chisel*, 779  
*Standard*, 770
- Critical cooling rate, 359
- Critical diameter, 385
- Crocar* steel, 777
- Croloy* steel, 777
- Cromansil* steel, 670
- Cromovan* steel, 777
- Cross-country mill, 423
- Crow* steel, 775
- Crown* steel, 775
- Crucible process for steelmaking, 190  
 tonnage produced since 1925, 182
- Crystallographic planes, 78
- CS-50*, 815
- CS-53*, 815
- CuAu, 272
- Cu<sub>3</sub>Au, 272
- Cu-Lead-Itc*, 823
- Cunico 21*, 875
- Cunife*, 875
- Cupola melting of cast iron, 174
- Cupping, 436
- Cupronickel, 581-583
- Cupron*, 843
- Curie point, 99
- Cusiloy*, 719
- Cutlasta*, 827
- Cutlery-type stainless steel, 607
- Cutting, and cold forming, tools for, 769-775
- Cyaniding, 735
- Cyclops Standard* steel, 770
- Cylinder-head alloys, cast aluminum, 660
- C.Y.W.* steel, 780
- Dacar* steel, 769
- Damascus steel, 514
- Damping capacity, 43
- D'Arcet's alloy*, 864
- D-B-L Regular* steel, 786
- Dead load, 664
- Debismuthizing of lead, 254
- Decarburization by water vapor, 375, 376
- Deep-drawing steels, 529  
 constitutional diagram, 341  
 property changes during precipitation hardening, 345, 346  
 killed vs. rimming steels for, 219, 220
- Deep-etch test, 767
- Defects in steel ingots, 205, 217-225
- Defiheat* steel, 612
- Defirust* steel, 607
- Deformation, 17, 31-34, 80-85  
 lines in brass, 83, 84

- Denseness, 50–52  
 Density, 50  
 Dental amalgams, 865  
 Deoxidation, 194, 211–214, 219–222  
 Deoxidized copper  
   high-conductivity, 836  
   low-conductivity, 836  
 Design factors, 399, 400, 624, 675  
 Desulfurization by manganese, 194, 213,  
   219; by calcium carbide, 211  
*Deward* steel, 775  
 Dezincification, 492  
 Dezincing of lead, 254  
 Diamagnetism, 55  
 Die-casting, 407–410  
   alloys, 560–570  
 Diescher process, 433  
 Die steels, 775–779, 779–782  
 Dies, forging, 427  
 Diffusion, 265  
   effect on bainite formation, 355  
   effect on coring, 281, 282  
   in soldering, 869  
*Di-Mol* steel, 786  
 “*D*” *Nickel*, 636  
 Direct casting (see continuous casting)  
   extrusion, 411  
 Dirty steel, 205, 206, 224  
 Disordered solid solution, 272  
 Distortion in castings, 398, 399  
*Doler-brass*, 568  
*Doler-zink*, 560  
 Double piercing, 432  
   plate gold filled wire, 520  
   refined wrought iron, 184–185  
 Dow chloride process for magnesium,  
   126–128  
 Dow sea water process for magnesium,  
   129–130  
*Downmetal C*, 717  
   *E*, 665  
   *FS-1*, 551, 714  
   *G*, 717  
   *H*, 717  
   *J-1*, 551, 714  
   *JS-1*, 551  
   *K*, 566  
   *L*, 715  
   *M*, 551, 714  
   *O-1*, 714  
   *R*, 566  
*Draco V* steel, 770  
 Draw casting, 405  
 Drawing, 388  
   tube, 438  
   rod and wire, 439–441  
   temperature, 769  
*Dreadnought High Speed* steel, 784  
*Driver-Harris* 720, 729  
 Drop forging, 427  
 Drossing furnace for lead, 253  
 Ductility, 34  
   tests, 537  
*Dumet*, 855  
 Duplexing, 181, 209  
 Duralumin-type alloys, 340–344, 347, 703.  
*Duredge Chisel* steel, 773  
*Durex*, 824  
*Durichlor*, 628  
*Duriron*, 627  
*Duro-Gloss CI* steel, 605  
   *C2*, 608  
   *C3*, 611  
   *C4*, 612  
*Duronze II*, 719  
 Dwight-Lloyd sintering machine, 250  
   for copper ores, 230  
   for lead ores, 249, 250  
*DW Metal*, 503  
*D.Y.O.* steel, 781  
*D-2*, 811  
*D-6-Co* steel, 790  
*D-29* steel, 773  
  
*Eagle B*, 827  
*Easy-Flo*, 867  
*EB Alloy* steel, 780  
*E.H.W. No. 1, No. 2 and No. 3* steels, 781  
 Elastic limit, 29  
   strain, 17  
 Eldred draw casting process, 405  
*Electrex* steel, 769  
 Electric-arc cutting, 479  
   furnace, for steelmaking, 210  
 Electrical conductivity alloys, 833–841  
 Electrical resistance alloys, 841–848  
 Electrical steel, Hadfield, 878  
 Electric furnaces, 113–120  
   steel, 210, 212; steelmaking tonnage  
   produced since 1925, 182  
*Electrite No. 1* steel, 784  
   *No. 19*, 785  
   *Uranium*, 786  
 Electrode potentials, 12  
   shapes in electrolytic refining, 237

- Electrodeposition, 504  
 barrel, 508  
 for building up sections, 453  
 of aluminum from molten salts, 137  
 of bearings, 896  
 of copper, 236–239, 509  
 of chromium, 510  
 of magnesium from molten salts, 126–130  
 of nickel, 245, 510  
 of tin, 259, 512  
 of zinc, 152, 507
- Electrolytic corrosion, 487  
 powder, 450  
 refining of aluminum, 139; of copper, 236–239; of lead, 255; of nickel, 244–246; of tin, 259; of zinc, 152
- Electrolyte, 10
- Electromagnets, 56–57, 884
- Electrometallurgical processes, 109
- Electrons, 3
- Electroplating, 504–513 (see also electro-deposition)  
 for wear resistance, 742
- Electro-sheet copper, 538
- Elektron process for magnesium, 128
- Elgiloy*, 857
- Elinvar*, 856  
*Extra*, 857
- Eloxal process, 521
- Ely process for wrought iron, 188
- Embossing, 440, 443
- Enduro AA* steel, 608  
*AA-Hi Carbon*, 608  
*F6*, 607  
*HC*, 612  
*NC-3*, 625  
*S-Hi Carbon*, 607  
*S-1*, 607  
*4-6 Cr*, 603
- Energizer in carburizing, 735
- Engine brass, 820
- Engineering metals, 5
- Epstein test, 876
- Equiaxed grains, 68
- Equicohesive temperature, 85, 87
- Equilibrium diagrams (see constitutional diagrams)
- Equilibrium state, 69–70
- Ericksen ductility test, 537
- Etching, 71, 72  
 effect on twins, 85
- Eutectic, 284  
 in iron carbon alloys, 307  
 in simple idealized diagram, 289  
 in silver-copper alloys, 284  
 in tin-zinc alloys, 289  
 occurrence of, 287  
 reaction, 285  
 typical metallographic structures, 285
- Eutectoid, 307
- Everdur*, 719
- E.V.M.* steel, 785
- Ex-B metal*, 820
- Excelo* steel, 779
- Ext-Die* steel, 776
- Explosive rivets, 452
- Extra Chrome* steel, 780  
*Special High Speed* steel, 785  
*Vanadium* steel, 770
- Extrusions, 409–417, 437  
 cable sheathing, 416  
 copper alloys, structure, 415  
 magnesium, high strength alloy, 414, 714
- E. 25* steel, 770
- Face-centered cubic space lattice, 76
- Factors of safety, 2
- Fahrte F-1* steel, 625  
*N-1*, 625  
*N-5*, 626  
*N-12*, 625  
*O-12*, 625  
*O-24*, 625  
*36-N*, 625
- Fast Finishing* steel, 773
- Fatigue, 38–41, 43
- Fecraloy*, 847
- Fernichrome*, 855
- Fernico*, 855
- Ferrite, 306  
 separation from austenite during cooling, 313
- Ferritic alloy steels, 326, 345, 605  
 malleable cast iron, 370  
 stainless steels, 608
- Ferromagnetism, 55
- Ferromanganese, 194–195, 213, 214
- Ferrosilicon in steelmaking, 195, 213, 219  
 in magnesium production, 134
- Films, effect on corrosion, 489  
 effect on quenching, 377
- Fine grain, 95, 96
- Finishing (Cr,W)* steel, 773

- Fire cracking, 438
  - of drawn tubing, 438
  - of nickel silver, 546
- Firthaloy*, 791
- Firthite*, 791
- Five Star High Speed steel*, 789
- Flame cutting, 478
  - hardening, 734
  - machining, 479
- Flash welding, 459
- Flotation, 108
- Fluxes, 110
- Forging, 426–428
- Foren process, 434
- Forging alloys
  - aluminum, 660, 707
  - magnesium, 715
  - steels, 685
- Forge welding, 454
- Forming, and cold cutting, tools for, 769–775
- Formite steel*, 781
- Foundry pig iron, 158
- Fractures
  - fatigue, 39–40
  - intercrystalline, 572
  - transcrystalline, 572
- Frary metal*, 828
- Free-machining alloys, 556–560
  - high-conductivity copper, 839
  - Monel, 638
  - 18:8, 620
- Fusible alloys, 858
- Fusion welding, 456–469
  - temperature distribution, 461
- Furnaces, 111–120
  - air, 176
  - blast, 112, 159–167, 231, 251, 257
  - cupola, 174
  - fuel-fired, 113–114
  - open hearth, 198–199
  - puddling, 182
  - reverberatory, 112
- F2 Bearing Bronze*, 821
- F-3*, 813
- F-11*, 827
- F-17 bronze*, 821
- F-23*, 812
- F-1260*, 626
- F-1824*, 625
- Galvanic action, 167, 487
  - corrosion, 487
- Galvanic action in sea water, 488
- Galvanizing, 499
  - bridge cable, 673
  - electro, 507
  - hot dip, 499, 501
- Galvanic cell, 16
- Gangue, 106
- Gaseous carburizers, 736
- Gas evolution during solidification, 217
  - water and producer, 13
  - welding, 459
- Genarco Connecting Rod*, 811
  - Tractor*, 828
- Genuine Babbitt*, 811
  - Sovereign Babbitt*, 810
- Gilding metal, 540
- Glacier Anti-Friction*, 827
- Globar* heating elements, 848
- Gold-filled wire, 520
- Gooseneck die casting process, 408
- Goss direct casting process, 404
- Government bronze, 588, 822
- Grains, 67–68
- Grain boundaries, 68
- Grain size, 68
  - A.S.T.M. standards, 73, 74, 75
  - austenitic, 73, 101
  - effect of hot work, 104
  - effect of rate of cooling on, 98
  - effect on cold working, 89
  - effect of hardenability, 363, 383
  - effect on machinability, 476
  - ferritic, 101
  - Jeffries method for measuring, 74
  - measurement, 74
  - nonferrous, 75
  - of castings, 398
  - on heating, 462
  - on welding, 462
- Grain growth, 67, 68
  - abnormal, 41
  - after recrystallization, 94, 462
  - coarsening temperature, 95
  - during welding, 462
  - effect of impurities, 95
  - effect of time on, 97
- Gramix*, 824
- Grant*, 827
- Granite City HSI and HS2 steel*, 670
- Graph-Al steel*, 790
- Graphite bronze, 264, 824
- Graphitic steels, 477, 557, 790
- Graph-M.N.S. steel*, 790



- Graph-Mo* steel, 790  
*Graph-Sil* steel, 790  
*Graph-Tung* steel, 790  
 Grating effect from etched pearlite, 308  
 Gravity casting, 392  
 Gray cast iron, 169, 329, 558, 696  
     constitution, 329, 331  
     dies, 795  
     fractures, 170–171  
     graphite flake sizes, 330  
     high strength, 696  
     microstructure, 331  
     wear resistant, 749  
*Green Label* drill rod, 769  
 Green water trouble, 578  
 Grinding, 481  
 Growth of cast iron, 631  
*G.S.N. Special* steel, 777  
 Guerin process, 797  
*Gunitite-K*, 702  
 Gun metal, 822
- Hadfield electrical steel, 878  
 Hadfield's manganese steel, 746  
*Halcut* steel, 779  
*Halcomb* steel, 790  
     *Hot Work* steel, 781  
*Haldi* steel, 777  
 Hall-Heroult process, 137  
 Hammer forging, 427  
 Hand puddling of wrought iron, 182–184  
 Hansgig process for magnesium, 132  
 Hard babbitt, 810  
 Hardenability, 363, 383–387  
 Hardenable stainless steels, 604–608  
*Hard Genuine Babbitt*, 826  
 Hard lead, 259  
     solders, 451  
 Hardness, 20–25  
 Hardware and fitting alloys, 556–570  
*Hastelloy*, 646, 651  
 Hazelett strip casting process, 407  
 Heap roasting, 229  
 Hearth-type furnace, 112  
     roasting, 229  
 Heating after cold work, 89, 90, 91–92  
 Heating curves, 65, 66  
*Heat Res. #5B*, 625  
 Heat resistance, 38  
 Heat-resisting cast iron, 631  
 Heat-treatment, 335–389  
     austempering, 350, 374  
     Heat-treatment, constant heat-treatment  
         vs. constant structure, 368  
     conventional for steel, diagram, 376  
     effect of time, 338  
     following carburizing, 738  
     involving allotropic changes, 348  
     of bridge cable, 672  
     of carbon-steel castings, 691  
     of cast irons, 698  
     of high speed steels, 787  
     of low alloy tool steels, 763  
     of magnet steels, 872  
     of rail steels, 745  
     of special magnetic alloys, 883  
     precipitation hardening, 339–348  
     recrystallization, 336  
     stress relief, 337, 373  
     (see also commercial heat treatments)  
 Heavy-duty lead-base babbitt, 811  
*Heller's Blue Label* steel, 769  
     *Brown Label*, 780  
     *Green Label*, 769  
     *Orange Label* Chisel, 779  
     *Purple Label*, 769  
     *White Label*, 769  
     *Yellow Label*, 770  
*Herculoy*, 719  
 Heroult furnace, 113  
 Heusler alloys, 875  
*Hewitts Bearing*, 827  
     *Fine*, 811  
 Hexagonal close-packed space lattice, 78  
*Hiduminium R.R.77*, 665, 705  
 High brass, 540  
     Erichsen tests on, 547  
     effect of annealing, 543  
     leaded, 559  
 High-carbon, high-chromium die steels, 777  
 High-carbon, low-tungsten tool steels, 771  
 High-conductivity copper, 833  
     deoxidized, 836  
     free-machining, 836  
 High current-density process for electro-  
     lytic deposition of zinc, 152  
 High-frequency induction furnace, 120  
*Hi-Gloss* steel, 616  
 High-purity copper, 241  
 High-silicon cast iron, 627  
 High-speed steels, 783  
 High-strength cast iron, 697  
     manganese bronze, 725  
 High temperature properties, 35–38, 593–  
     598

- High-test cast iron, 697  
 High-tin lead-base bearing alloys, 827  
*Hipernik*, 882  
*Hi-Pro* steel, 777  
*Hitenso*, 840  
*H. M. High Speed* steel, 786  
 Hollowware, sterling silver, 865  
 Honeycomb pitting, 491  
 Hooker process, 417  
 Hooke's law, 30  
 Horizontal retort process for zinc, 145  
 Horizontal-retort redistillation of zinc, 147  
*Hot Die No. 2* steel, 780  
*Hot Form* steel, 783  
 Hot-dipped coatings, 499–503  
   extrusion, 409  
   blast furnace iron, 165  
   -shortness in aluminum die castings, 563  
   tops on steel ingots, 216  
   -work, 104, 418; cartridge brass, 419; effect on grain size, 104; tools for, 779–791  
*Hoyt's CB*, 827  
   *Genuine A*, 810  
   *Reliance*, 827  
*H. R. W.* steel, 270  
*Huron* steel, 777  
*H. V. High Speed* steel, 785  
   *Blue Chip* steel, 785  
 Hybinette electrolytic process for nickel, 244, 245, 246  
 Hydrogen, solubility in iron, nickel and chromium, 217  
   embrittlement of copper, 538, 856  
 Hydrometallurgical processes, 109  
*Hyglo Lusterite* steel, 608  
 Hypereutectoid, 309  
*Hypersil*, 881  
 Hypoeutectoid, 309  
 Hysteresis, 55, 878  
   pure iron vs. Armco iron, 878
- I.A.C.S. conductivity, 833  
 Idiomorphic grains, 68  
 Ihrigizing, 515, 516  
*Illium*, 649  
 Impact extrusion, 417  
   strength, 26  
   tests, 27–29  
 Impingement corrosion, 491
- Impurities  
   effect on conductivity of copper, 834  
   in aluminum, 140  
   in bearing metals, 808  
   in rolling cartridge brass, 419  
   in electrodeposition of zinc, 152  
   in iron, 156, 208, 878  
   in tin, 260  
   removal in Bessemer process, 192, 198  
   removal in electric process, 210  
   removal in open hearth process, 200–205  
 Incendiary bomb charges, 457  
 Inclusions in steel, 205, 206, 224  
 INCO direct casting process, 405  
*Inconel*, 644  
   -clad steel, 519  
*Indilitans*, 853  
 Induction furnace, 113, 116  
 Induction hardening, 731  
 Ingot, 214–216  
   blowholes, 217, 223  
   capped, 222  
   cropping, 216  
   defects, 223, 224  
   laminations, 224  
   killed, 219, 220  
   piping in, 213, 216, 223  
   rimmed, 219, 220, 221  
   segregation, 217, 218, 223  
   semikilled, 219, 220  
   stage of steel making, 212  
   use of hot tops, 216  
   vs. casting, 391  
 Ingot iron, 208–209, 526–528, 878  
 Ingotism, 224  
*Inland Hi-Steel*, 670  
 Intermediate-alloy steel, 598  
 Intermediate solid solution (see secondary solid solution)  
 Intermetallic compounds, 268, 271  
   in bearing alloys, 804, 807, 813, 815  
   in dental amalgams, 865  
   CuAu, 272  
   Cu<sub>3</sub>Au, 272  
   Cu<sub>4</sub>Sn, 304  
   Fe<sub>3</sub>C, 272  
   Mg<sub>2</sub>Si, metallographic structure, 273  
 Internal stresses, 337  
   general effect on corrosion, 17  
   in drawn steel rod, 442  
   in tubing, from sinking vs. drawing, 439

- International Tin Cartel, 257  
 Internal surfaces, effects on solid state reactions, 339  
 Interrupted quenching, 379  
 Interstitial solid solution, 269  
*Interurban No. 27*, 811  
*Invar*, 853  
   for controlling-expansion of aluminum pistons, 662  
   *Cast Iron*, 854  
*Invaro Oil Hardening steel*, 776  
 Inverted extrusion, 411  
 Investment casting, 401  
 Iron, 99, 155  
   allotropic recrystallization, 101  
   allotropy, 99-100  
   cemented, 180  
   ingot, 208  
   pure, 877  
   reduction, 157  
   transformation nomenclature, 100  
   wrought, 180  
 Iron alloys  
   aluminum-iron, transformer alloys, 881  
   binary alloys, constitutional diagrams (see constitutional diagrams); effects of carbon, 322, 324  
   -carbon alloys, 305, 312, 329, 341;  
     application of 1:2:1 rule, 306;  
     constitutional diagram, 305, 312;  
     effects of alloying elements on eutectoid composition, 325; effects of alloying elements on eutectoid temperature, 325; effect of carbon content on hardness of tempered steels, 361, 362; effects of chromium on limits of austenite, 323; effects of manganese on limits of austenite, 323; effects of molybdenum on limits of austenite, 323; effects of silicon on limits of austenite, 323; iron-graphite, 329; metallographic structures, 307-310; property changes vs. percentage carbon, 318-320; reaction of constituents to etching, 310; structural changes during cooling, 311-315; transformation nomenclature, 311  
   carbide (see cementite)  
   -cerium, 321  
   -cobalt-tungsten tool, 798  
   Iron alloys (*cont'd*)  
     -copper, 321  
     for powder bearings, 832  
     magnet, 873  
     -molybdenum, 321  
     -nickel, 321, 881  
     resistance alloys, 847  
     -silicon electrical, 878  
     stainless, 604, 608  
     -tungsten-molybdenum tool, 798  
     (see also steels, cast iron, ingot iron)  
   *Iso-elastic Alloy*, 857  
   Isotope, 3  
   Izett steel, 535  
   Izod impact test, 27, 28  
  
*Jal-Ten*, 670  
*Jessop Special Oil Hardening steel*, 775  
*J Hot Working Die steel*, 780  
*Johnson Bronze Babbitt No. 10*, 810  
   *Babbitt No. 11*, 811  
   *Graphited Bearings*, 824  
 Joints, welded, 469  
   riveted, 453  
 Jominy test, 385, 386  
*J.S. Punch & Chisel steel*, 779  
 Journal brass, 824  
  
 Kalunite process for metal grade alumina, 139-140  
*Kanthal*, 847  
*Kennametal*, 791  
*Ketos steel*, 776  
*Keystone Alloy Chisel steel*, 779  
   *Copper Steel*, 528  
 Killed steel, 219, 220  
 Kiln roasting, 229  
*Kirksite*, 797  
*Kiski steel*, 776  
*K-L steel*, 783  
*K-M steel*, 783  
 "K" *Monel*, 641, 665  
*Konal*, 649  
*Konik*, 670  
*Kovar*, 855  
*K-R steel*, 783  
*Krovan steel*, 775  
 Krupp analysis, 757  
*K-S steel*, 783  
*Kunial*, 582  
*Kutkwik steel*, 784  
*K42B*, 650

- Labelle No. 89 steel*, 780  
 Lake copper, 833  
 Laminations, 224  
 Lang process, 698  
 Lap welding, 430, 459  
 Latent heat of transformation, 64  
     fusion, 64  
     vaporization, 64  
*Latimo steel*, 786  
*Latrobe Double Six steel*, 787  
*LB-142*, 827  
 Leaching, 108  
     copper ores, 239  
 Lead, 247  
     Betts electrolytic process, 255  
     blast furnace smelting, 251  
     cable sheathing, extrusion of, 414  
     coatings, 503  
     commercial grades, 256  
     corroding, 254  
     debismuthizing, 254  
     dezincing, 254  
     drossing, 252, 253  
     Dwight-Lloyd roasting, 244, 250  
     hydrometallurgical processes, 255  
     impurities in, 256  
     ores, 249  
     Parkes desilverizing, 254  
     softening, 252  
     roasting or sintering, 249  
     treatment of sulfide ores, 248, 249  
     volatilization processes, 256  
     Waelz process, 256  
 Lead alloys, 553  
     antimonial, 655  
     bearings, 826-829  
     calcium, 655  
     chemical, 653  
     chemical resistance, 653  
     solders, 862  
     tellurium, 654  
 Leaded babbitts, 825  
     brass, 475, 558  
     copper, 839  
     manganese bronze, 725  
     nickel-bronze castings, 724  
     phosphor bronze, 722  
*Lead Sealed*, 503  
 Le Chatelier's principle, 122  
 Lectromelt electric furnace, 115  
 Ledeburite, 308  
*Ledloy steel*, 557  
*Lehigh Die and Tool "H" Temper steel*, 777  
     "*S*" Temper, 777  
*Lesco "H" steel*, 611  
     "*HH*," 612  
     *L and LS*, 607  
     18-8, 616  
 Leveling, 442, 446  
 Lever rule for binary constitutional diagrams, 280  
*Liberty steel*, 773  
 Life test for resistance alloys, 842  
 ✓ Light metal alloys for strength, 703-718  
 Lime-sinter process for metal grade alumina, 139, 142  
 Limiting solid solution, 286  
 Lindberg-Fisher furnace, 118-119  
*Lion steel*, 769  
*Lipowitz alloy*, 864  
 Liquid carburizers, 735  
 Liquid solutions, 262  
*L.M.W. steel*, 786  
 "*L*" Nickel, 635  
*LoCro 46 steel*, 603  
 Lo-Ex alloy, 659  
*Lohm*, 843  
 Looping mill, 423, 424  
 Lorentz law, 45  
 Lost wax process, 401  
*Lotus*, 827  
 Low-alloy steels, wrought, 669; cast, 693  
     brass, 540  
     -carbon steel, 598  
     -conductivity deoxidized copper, 836  
     current-density process for electrolytic deposition of zinc, 152  
     expansion alloys, 852  
     -frequency induction furnace, 117  
     melting solders, 863  
     temperatures, effect on mechanical properties of 18:8 stainless steel, 678; of Monel metal, 640  
     -tin lead-base bearing alloys, 827  
     -tungsten, high-carbon tool steels, 771  
 Ludlum-type electric furnace, 113  
 Lueder's lines, 442, 534  
 Luerssen-Greene impact test, 28, 29  
*Lumdie steel*, 783  
*Lumen Alloy No. 4*, 821  
     *Alloy No. 33*, 823  
     *Bronze*, 816  
 Lump brazing solder, 868

- Lurgimetall*, 828  
*LXX* steel, 784  
*L100*, 828
- MacDougall roasting furnace, 230  
 Machinability, 472–477  
 Machinable alloys, 474–477, 556, 560  
 Machining, 472
  - flame-machining, 479
- Magnaflux, 53, 54, 471  
 Magnaglow, 53, 54  
 Magnesium, 125–135
  - alloys, casting, 717; die casting, 566; forging, 715; high-strength extrusions, 714; sheet, 551; (see also *Dowmetal* and *Mazlo*)
  - commercial specifications, 135
  - Dow chloride process, 126–128
  - Dow sea water process, 129–130
  - Elektron process, 128–129
  - Ferrosilicon process, 134–135
  - Hansgirg process, 132–134
  - M.E.L. process, 128
  - methods of reduction, 126
  - ores, 125, 126
  - oxide process, 130–132
  - Pidgeon process, 134–135
- Magnetic concentration, 108
  - materials, 870–876
  - properties, 55–56
- Magnet steels, 871  
*Magnolia Bearing Bronze*, 821
  - Defender*, 828
- Majestic Babbitt*, 826  
 Malleable cast iron, 177, 370, 699  
 Malleability, 34  
*Mallix*, 702  
*M & E Imperial*, 828  
 Manganese bronze, 724
  - die castings, 569
  - nondeforming die steel, 775
  - steel, austenitic, 746–748
  - structural, 668
- Manganin*, 843  
*Mangano Special* steel, 776  
 Mannesmann process, 431  
*Mansil Oil Hardening* steel, 776  
*Man-Ten* steel, 670  
*Marathon* steel, 777  
*Marine Babbitt*, 826  
 Martempering, 380  
 Martensite, 353, 356–357, 360–364, 381
- Martensitic malleable cast iron, 702  
*Marvel* steel, 781  
*Matrix* alloy, 865  
 Matte, copper, 231
  - lead, 252
  - nickel, 243
- Maxite Super High Speed* steel, 785, 789  
*Mayari R* steel, 670  
 Mazlo alloys,
  - AM3S*, 551, 714
  - AM52S*, 551, 714
  - AM57S*, 551, 714
  - AM58S*, 714
  - AM65S*, 715
  - AM230*, 566
  - AM240*, 717
  - AM260*, 717
  - AM263*, 566
  - AM265*, 717
  - AM403*, 717
- McQuaid-Ehn test, 739  
 Measurement of grain size, 74  
 Mechanical mixtures of solid phases, 275–280
  - properties of basic open hearth vs. acid Bessemer steels, 207, 208; of heat-treated S.A.E. steels, 687
  - puddling of wrought iron, 188
  - twinning, 83
- Medart straightening, 444, 447
  - effect on internal stresses in brass, 493
- Medium-manganese cast steels, 695  
*Meehanite*, 699, 702  
 Melting temperatures of engineering metals and alloys, 48–49  
 M.E.L. process for magnesium, 128  
 Melting of metal, 393  
 Merchant mill, 423
  - bar, 184–185
- Mercurous nitrate test, 494  
 Metals, 3–8, 106, 64, 99
  - arc welding, 466
  - clad coatings, 517–520
  - grade alumina, 137–139
  - ion concentration cell, 17
  - spraying, 453
  - working dies, 775–779, 795
- Metallography, 1  
 Metallurgy, scope, 1  
 Microbearings, 805, 812  
*Midohm*, 843  
*Midvaloy 13-00* steel, 607
  - 13-00A*, 607

- Midvaloy 17-00*, 608  
   26-02, 612  
 Mild steel, 529, 575  
   -alloy structural, 669  
   Olsen tests on, 537  
 Milled powder, 448  
 Minerals, 106  
*Miner's Drill* steel, 769  
*Minovar*, 854  
*M.L.* steel, 785  
*Misco Metal*, 625  
*Mo-Cut* steel, 786  
 Modified cutlery type stainless steel, 607  
   structures in aluminum-silicon alloys,  
   713  
   *Wood's metal*, 865  
   18:8 alloys, 620  
*Mogul* steel, 786  
 Modulus of elasticity, 30-34, 665  
*Mohawk Babbitt*, 828  
*Mohican* steel, 786  
 Molding metal powders, 450  
 Molds, foundry, 392, 394  
   ingot, 214  
*Molite 5* steel, 786  
   8, 786  
 Molybdenum cast steels, 696  
 Molybdenum heating units, 846  
 Molybdenum high-speed steels, 787  
*Mo-Max* steel, 786  
 Mond process for nickel, 246, 248  
*Monel* metal, 243, 270, 554, 637  
   -clad steel, 519  
   for ball bearings, 757  
*More Jones Crescent*, 827  
   *Improved*, 828  
   *Hoo Hoo*, 810  
   *Nickel*, 811  
 Morgan mill, 422  
 Mottled cast iron, 171  
*Mo-Tung* steel, 786  
*Mo Van No. 2* steel, 786  
 Moving mold direct casting, 405  
 Mt. Hope Bridge failure, 672  
 Muffle-type furnace, 113  
 Multiple system of copper refining, 236, 238  
   hearth roasting, 230  
*Multole Punch* steel, 773  
*Mumetal*, 882  
 Muntz metal, 578  
   for water pipe, 576  
   structure in extruded shapes, 415  
 National Emergency steels, 688  
 Naval brass, 581  
   metallographic structure of extruded  
   shapes, 415  
*Navy Antifriction Metal Grade 1*, 810  
   *Grade 2*, 811  
   *Grade 6*, 828  
   *Grade 7*, 827  
*N-A-X-High Tensile* steel, 670  
*NCT-3*, 625  
 N.E. steels, 688  
 Neumann bands, 83-84  
*Newton's alloy*, 864  
*Nicaloi*, 882  
 Nicarb process, 737  
 Nichols-Herreshoff roasting furnace, 230  
*Nichrome*, 625, 846  
   II, 845  
   V, 844  
 Nickel, 270, 633, 241  
   -clad steel, 519  
   commercial grade, 247  
   converting, 243  
   effect on gray cast iron structure, 173  
   Hybinette electrolytic process, 244-  
   246  
   Mond process, 246, 248  
   ores, 241  
   Orford process, 243, 244  
   tops-and-bottoms process, 243, 244  
   treatment of silicate ores, 242  
   treatment of sulfide ores, 243  
   washed sulfide, 245  
 Nickel alloys  
   "A" *Nickel*, 633  
   -antimony-lead bronze, 821  
   -bronze castings, 723  
   carbon-free nickel, 635  
   cast *H Monel*, 638  
   cast *Monel*, 643  
   cast nickel, 633  
   cast *S Monel*, 638  
   cast steels, 694  
   nickel coatings, electroplated, 510;  
   nickel-clad steel, 519; to prevent  
   nitriding, 741  
   "D" *Nickel*, 636  
   *Hastelloy*, 646  
   *Illium*, 649  
   *Inconel*, 644  
   "K" *Monel*, 641  
   *Konal*, 650  
   "KR" *Monel*, 642  
   *K42B*, 650

- Nickel alloys (*cont'd*)  
 "L" Nickel, 635  
 low expansion alloys, 852  
 magnetic alloys, 882  
 -manganese steel, 748  
 Monel metal, 243, 637  
 nickel, 633  
 vs. nickel-molybdenum couple, 851  
 resistance alloys, 843-846  
 "R" Monel, 638  
 nickel silver, 544  
 structural steel, 668  
 "Z" Nickel, 636  
 Ni-Hard, 754  
 Nilox, 853  
 Nilvar, 853  
 Ni-Resist, 628  
 Nirosta KA2 steel, 616  
 Ni-Span-C, 857  
 Ni-Span-Hi, 856  
 Ni-Span-Lo, 854  
 Nital, 309  
 Ni-Tensyl iron, 698  
 Nitralloy, 741  
 Nitriding, 741  
   cast steels, 694  
 Nivan steel, 775  
 Noble metals, 5, 8  
 Noble metal 'ouples, 851  
 Nonaging steel, 535  
 Non-Bessemer iron ores, 164  
 Nondeforming die steels, manganese, 775  
 Nonsparking tools, 797  
 Normal vs. abnormal steels, 739  
 Normalizing, 372  
 Normal structures,  
   aluminum-silicon, 713  
 Norton damping capacity tester, 42  
 Notch sensitivity, magnesium alloys, 717  
 No. 1 manganese bronze, 725  
 No. 4 steel, 773  
 No. 11 Special steel, 769  
 No. 57 Hot Work steel, 781  
 No. 58 alloy, 841  
 No. 67 Chisel steel, 779  
   Tap, 772  
 No. 71 steel, 773  
 No. 445 Hot Work steel, 780  
 Nut Piercer steel, 781  
 N 30, 883  
 Ohmaloy, 605  
 O.F.H.C. copper, 835, 837  
 Ohio Die steel, 777  
 Ohmax, 847  
 Oilite, 824  
 Oilless bearings, 265, 807  
 Oil quenching, 379  
 Oil-refinery tubes, 598  
   cast iron, 576  
   low-carbon, 598  
   4-6% chromium, 599  
 Olsen ductility test, 537  
 Olympic bronze, 719  
 Omega steel, 773  
 One Star High Speed steel, 786  
 Ontario steel, 777  
 Open hearth process for steel, 182, 198  
 Orange peel surface, 85, 86, 675, 531, 537  
 Ordered solid solution, 272  
 Ores, 106  
   aluminum, 136, 139  
   beneficiation, 108  
   Bessemer, 164  
   copper, 227, 228  
   impurities in, 107, 156  
   iron, 155  
   lead, 249  
   magnesium, 125, 126  
   nickel, 241  
   non-Bessemer, 164  
   tin, 257  
   zinc, 143  
 Orford process for nickel, 243, 244  
 Orion steel, 775  
 Otiscoloy steel, 670  
 Otisel K-4 steel, 603  
 Ounce metal, 586  
 Oxidation, 9  
   and chemical activity, 14  
   and purification, 14  
   corrosion, 486  
 Oxide process for magnesium, 130-132  
 Oxyacetylene welding, 459  
   flame, 460  
 Oxygen concentration cell, 17  
   -free copper, 240; metallographic  
   structure, 241  
 Oxyhydrogen welding, 459  
   flame, 460  
 Pack carburizing, 735  
 Painting, 523  
 Paramagnetism, 55  
 Para steel, 773  
 Paragon Oil Hardening steel, 775

- Par Exc* steel, 779  
 Parkes process for desilverizing lead, 254  
 Parkerizing, 521  
 Passivation, 522  
 Patterns, 391, 392  
 Patent leveling, 442, 446  
 Patina, 519, 520, 538  
 Patterns, 391  
 Pay load, 664  
 Pearlite, 308, 350–353, 363
  - effect of cooling rate on structure, 380, 381
  - grating effect by etching, 308
  - microstructure, 309, 316, 352, 363, 381
  - nodular, 352, 360, 363
  - possible modes of formation, 354
  - properties, 357
  - property changes during spheroidizing, 361
  - properties of lamellar vs. spheroidal structures, 362
- Pearlitic malleable cast iron, 701  
 Peening, 464  
*Peerless A, B, C, and D* steels, 781  
 Percentage distribution of metals in earth's crust, 106  
*Perduro*, 702  
 Periodic table, 4  
 Peritectic, 294–296, 306  
*Permalloy*, 882  
 Permanent magnet, 56, 57
  - steels, 871
- Permeability, 55, 881–884  
*Permendur*, 882  
*Perminvar*, 883  
 Pewter, 569
  - solders for, 863
- P-F test for hardenability, 384  
 Phases, 266, 268  
*Phoenix*, 810  
*Phoenix* steel, 780  
*Phonoelectric bronze*, 840  
*Phosnic* bronze, 841  
 Phosphor bronze, 720  
 Phosphorus prints, 219
  - deoxidized copper, 240, 241
  - segregation in steel, 219
- Photoelectric control in Bessemer process, 196  
 Pickling, 371  
 Picral, 309  
 Pidgeon process for magnesium, 134  
 Piercing, 431  
 Pig iron, 157–158, 168  
 Pilger process, 433  
 Pinch effect, 117  
 Pipe, manufacture of, 403, 416, 429–438
  - to resist water corrosion, 572–586
- Piping, extrusion defect, 412
  - in ingots, 214, 216, 223
- Piston alloys, aluminum, controlled expansion, 661
  - cast aluminum, 656
  - forged aluminum, 660
- Pitting, 491  
 Planes, crystallographic, 78
  - close-packed, 79
- Plastic strain, 17  
*Plate-loy*, 503  
 Plating (see electrodeposition and electroplating)  
*Platinite*, 855  
 Plug rolling mill, 433  
 Plumber's brass, 588  
 Poland draw-casting process, 405  
 Poling in copper refining, 234
  - in tin refining, 259
- Pompton Standard* steel, 770  
 Porcelain enameling, 524  
 Powder metallurgy, 263, 444–451
  - aluminum bearings by, 818
  - bearings, 808
  - bonding of bearings to backing, 806
  - bushings, 807
  - magnet alloys, 873
  - production of powder, 448
- Power*, 828  
 Precipitation from solid solution
  - general types, 342, 343
- ✓ Precipitation hardening, 339–348
  - aluminum-copper alloys, 347
  - constitutional diagrams of alloy susceptible to, 339, 340
  - copper-beryllium alloys, 346
  - deep-drawing steels, 346
  - microstructure of typical slowly cooled alloys, 342
  - future importance, 348
  - magnet alloys, 872
  - rate vs. temperature, 347
  - solution annealing, 373
  - 18:8 type stainless steels, 621
- Precipitation in solid state, 288
  - general types, 342, 343
  - in alloy steels, 345



- Precipitation in aluminum-copper alloys, 342, 344  
 metallographic structures, 288  
 of carbides in stainless steels, 288, 345, 609, 614  
 property changes incident to, 345-347
- Precision casting, 401
- Preece test, 501
- Premium High Speed* steel, 828
- Press forging, 428
- Pressurdie* steel, 783
- Pressure casting (see die casting)
- Prevention of sensitization in 18:8 stainless steel, 616
- Primary solid solution, 268  
 constitutional diagram, 277  
 cooling curve typical of, 277  
 metallographic structure, 270  
 properties vs. composition, 169
- P. R. Mallory & Co. aluminum bearings, 818
- Process annealing, 373
- Proeutectoid, 309, 319
- Projection welding, 459
- Proof strength, 31
- Proportional limit, 30
- Protective coatings, 498  
 cemented, 513  
 electroplated, 504  
 hot dipped, 499  
 metal clad, 517  
 metal sprayed, 515  
 paint, 523  
 protective film type, 519  
 vitreous enameling, 524
- Pseudoeutectic in babbitt metals, 808
- Puddling of wrought iron, 182-184
- Punch and chisel tools, silicon-manganese, 773  
 tungsten-alloy, 779
- Puron*, 877, 882
- Pyro (Hot Die)* steel, 775
- Pyrometallurgical processes, 109
- Quenching, 375-379  
 effect of rate on structure, 380, 381
- Radiohm*, 847
- Railroad rail steel, 743-746  
 rolling, 423
- Random solid solution, 272
- Reaction tendency, factors affecting, 335
- Recalcescence, 100
- Recarburizing in Bessemer process, 194  
 open-hearth process, 204
- Recovery after cold work, 91
- Recrystallization, 89-94, 336  
 allotropic, 101  
 effect of rate of cooling after, 98  
 following cold work, 336  
 of cast structure, 92  
 strain-, 92
- Recuperative preheating system, 167
- Red Star Tool* steel, 769  
*Tungsten*, 772
- R.D.S.* steel, 775
- Red brass pipe, 576
- Red Cut Cobalt* steel, 789  
*Superior*, 784
- Redrawing, 443
- Red Tiger* steel, 785
- Red Streak* steel, 784
- Reduced powder, 448
- Reduction, 9  
 and chemical activity, 11  
 by carbon, 121  
 effect of temperature, 11, 13, 14  
 endothermic, 124  
 exothermic, 125  
 of iron oxides by CO, 122  
 of metal oxides by carbon, 124  
 of iron ore, blast furnace, 157;  
*Sieurin* process, 157
- Reeling, 434, 436
- Refining, 109
- Refractories, 110-111
- Regenerative preheating system, 167  
 process, 190, 200
- Regular S.S.* steel, 607
- Relative modulus of elasticity, 665  
 stiffness, 664  
 strength, 667
- Relaxation, 37
- Remanence, 56
- Republic Double Strength* steel, 670
- Residual or permanent magnetism, 871
- Resistance, heat, 38; electrical, 43  
 welding, 458
- Retrograde solubility, 286
- Reverberatory furnace, 112  
 air furnace, 176  
 copper, 232  
 lead dressing furnace, 253  
 tin, 258
- Rexalloy*, 793

- Rex AA steel**, 784  
*Champion*, 785  
*MM*, 786  
*-T-Mo*, 786  
*Supervan*, 785  
*VM*, 786  
 95, 790  
**Rezistal steel**, 620  
*KA2*, 616  
*2C*, 620  
*#7*, 625  
*#329*, 613  
*#330*, 625  
**Rich low brass**, 540  
**Rimmed steel**, 219, 220, 221  
**Riveting**, 452  
     grade structural steel, 669  
**"R" Monel**, 638  
**Roasting**, 108, 229–231  
     of copper ores, 229  
     of lead ores, 249  
**Rocking arc furnace**, 115  
**Rockwell hardness test**, 20, 21  
**Rod drawing**, 439  
     residual stresses in Bessemer steel, 442  
**Roe process for wrought iron**, 188  
*Rogers Special Engine*, 827  
**Rolled gold plate**, 519  
**Rolled zinc**, 554, 665  
**Roller bearings**, 756  
**Rolling**, 419, 421–425  
**Rolling mills**, 424–426  
*Roman Bronze*, 581  
*Roofloy*, 554  
*Rose's metal*, 864  
**Rotary rolling mill**, 433  
*R.T. Steel*, 773  
**Rules for binary diagrams**  
     composition, 279  
     Lever, 280  
     1:2:1, 290  
**Rustless 12 steel**, 607  
*13-C-35*, 607  
*17*, 608  
*17-C-60*, 608  
*17-C-80*, 608  
*17-C-100*, 608  
*21*, 611  
**S.A.E. numbering system**, 326, 327  
     steels, 530, 679–688  
**Safety system alloys**, 864  
**Saggers in malleablizing**, 177  
**Sampson metal**, 816  
**Sanderson Double Special steel**, 773  
     *Standard*, 770  
**Sandwich bearings**, 805  
**Saratoga steel**, 776  
**Saturn steel**, 773  
**Scabs in steel ingots**, 225  
**Scalping**, 412  
**Scleroscope**, 23  
**S-curve**, 351  
**Seam welding**, 459  
**Season cracking**, 493  
     of drawn tubing, 438  
**Seamless pipe and tubing**, 411, 416, 430–438  
**Secondary solid solution**, 268  
**Segregation**, 217–223  
**Selective carburizing**, 737  
**Selenium copper**, 839  
**Semikilled steel**, 219, 220  
*Seminole steel*, 779  
**Semired brass**, 587  
**Sensitization of 18:8 stainless steel**, 616  
     during welding, 679  
**Series system of copper refining**, 237  
*Service D Babbitt*, 826  
**Shaft-type furnace**, 112  
**Shapes made by extrusion**, 413  
**Shatter cracks, in rail steels**, 744  
**Sherardizing**, 515  
**Shielded arc welding**, 467  
**Shore scleroscope hardness test**, 23  
**Shorterizing**, 734  
**Shorter process**, 734  
**Shot welding**, 674, 679–680  
*Silchrome steel*, 611  
*Sicromo steel*, 603  
**Siemens-Martin process**, 181, 198  
**Sieurin process for sponge iron**, 157  
*Sil-Fos*, 867  
**Silico-ferrite**, 628  
**Silicon bronze**, 665, 718; fusion welding, 463  
     carbide heating elements, 848  
     cast iron, 627  
     effect on gray cast iron structure, 173  
     electrical steel, 878  
     -manganese punch and chisel tools, 773  
     structural steel, 669  
**Siliconizing**, 515, 516

- Silman* steel, 773  
*Simanal*, 875  
 Silver for electrical conductors, 833  
     alloys; bearings, 825; brazing, 451,  
     866; magnet, 875; solders, 451  
     brazing, 451  
     -clad iron, 520  
*Silver Star* steel, 769  
 Simple cubic space lattice, 76  
 Single-refined wrought iron, 184-185  
 Sinking, 435, 438  
 Sintered carbides, 791  
 Sintering of metal powder compacts, 451  
     of ores (see roasting)  
 Sizing of tubing, 434, 436  
 Skelp, 429  
 Slag, 109  
     blast furnace, 168  
     copper converter, 234  
     copper smelting, 232  
     from blast furnace making basic pig  
     iron, analysis, 158  
     lead blast furnace, 252  
     nickel converter, 243  
     steel open hearth, 202, 203  
     tin, 259  
     wrought iron, 187  
 Slip, 80, 81  
     lines, 81, 82  
 Slitting, 419  
 Smelting, 109  
     blast furnace, 231, 251, 257  
     reverberatory, 232, 258  
*S-Metal*, 812  
*Smith No. 10*, 847, 848  
 Sodium picrate, alkaline, 309  
 Soft babbitt, 810  
 Softening of lead, 252  
 Soft solders, 858  
     cored, extruded, 416  
     low melting, 863  
     substitute, 862  
 Soft spots from quenching, 398  
*Solar* steel, 773  
 Soldering, 451-452  
 Solder, brazing, 868  
     extrusion of, 416  
     gold, 866  
     silver, 866  
     soft, 858  
     spelter, 868  
     wire, manufacture, 416  
 Solid carburizers, 735  
 Solidification of liquids, 214-218, 223,  
     225, 397  
 Solid solution, 268-272  
     nonequilibrium solidification, 28  
     281, 282  
     equilibrium solidification, 277  
 Solution annealing, 373  
 Solvus, 286, 614  
 Sonims, 205, 206, 224  
 Sorbite, 365, 366  
 Sorbitic malleable cast iron, 702  
 Soro process, 403  
 Soundness, 395, 219-225  
 Space lattice, 65, 76-78  
 Spark test, 480  
*Special Alloy 51V* steel, 773  
 Special brasses  
     for resisting water corrosion, 579  
*Special High Speed* steel, 784  
*Special 1*, 828  
 Specifications, 61, 62  
 Specific gravity, 49  
 Specific heat, 54  
 Specimen size, effect on tensile properties,  
     34  
*Speed Star Molybdenum* steel, 786  
 Speed of testing, effect on tensile prop-  
     erties, 34  
 Speiss, 252  
 Spelter solders, 868  
 Sperry electrical test, 744  
 Spheroidized cementite (see spheroidite)  
 Spheroidite, 365  
     properties vs. lamellar structures, 36  
 Spinning, 442, 444  
 Sponge iron, 157  
     balls of wrought iron, 189  
 Spot welding, 458  
 Spiegeleisen, 195  
 Spring materials  
     beryllium copper, 726, 728  
     copper-nickel-manganese, 729  
     phosphor bronze, 720  
     steels, 687  
     stiffness vs. temperature relationship,  
     857  
 Sprinkler system fusible alloys, 864  
 Stabilized 18:8 stainless steel, 619  
*Sta-Gloss A* steel, 607  
     *B*, 608  
 Stainless-clad steel, 517, 518  
*Stainless "B," "BH," and "BHH"* steel,  
     608

- Stainless "C-2" steel*, 608  
     *"I,"* 607  
     *"N,"* 616  
     *#W,* 621  
     *#20,* 611  
     irons, ferritic type, 608; hardenable type, 604  
     less steel, 538, 603-625, 674  
     mping, 440  
     mping dies  
         cast iron, 795  
         steel, 775-779  
         zinc-alloy, 795  
     nnum, 811  
     *Max steel,* 786  
     *Mo steel,* 787  
     *Zenith steel,* 784  
     tionary mold direct casting, 404  
     adite, 331  
     nickel rolling process, 424, 426  
     *Steel-back Cleveite,* 823  
     steel bearing backings, 805  
     steel-core conductors, 838  
     steelmaking  
         acid Bessemer, 191  
         acid open hearth, 205  
         basic Bessemer, 198  
         basic electric steel, 210  
         basic open hearth, 198  
         clean steel, 205, 206  
         crucible, 190  
         deoxidation, 213  
         dirty steel, 205, 206  
         ingot stage, 212  
         solidification, 215  
         onnage produced since 1925, 182  
         blue brittle range, 420  
         carburizing, 681, 682  
         castings, 4-6% chromium, 599; hardenable type stainless, 608  
         electrical, 878  
         heat-treating, S.A.E. grades, 685  
         magnet, 870  
         N.E., 688  
         S.A.E., 326, 327, 679-688  
         screw machine stock, 556  
         spring, 687  
         structural, 665-669  
         tool, 761-791  
     *Tellite,* 612, 793  
         *No. 21,* 651  
     *Steator steel,* 775  
     Sterling silver, 286  
     *Sterling V steel,* 769  
         *XX,* 769  
     Stethoscope test for soundness, 53  
     Step-bar test for cast iron, 173  
     Stiefel process, 431  
     Stiffening castings with ribs, 401  
     Stiffness vs. temperature for spring materials, 857  
     St. Joseph Lead Company's electrothermic process for zinc, 150  
     *S.T.M. steel,* 786  
     Stoves, 167  
     Straightening, 442-447  
     Strain, 17  
     Strain aging  
         in mild steel, 532  
     Strain recrystallization, 92-94  
         effect of rate of cooling on grain size, 98  
     Strategic metals, 7  
     Strauss solution, 616  
     *Street's No. 4,* 828  
     Strength properties, 26-38  
     Stress corrosion, in brazing, 868  
         cracking of 18:8 vs. 17:7, 621  
         cracking of drawn tubing, 438  
         cracking, 493  
         of boiler plate, 573  
     Stress relief annealing, 337, 373  
         of welds, 470  
     Stretcher leveling, 442, 446  
     Stretcher strains, 442, 534  
     Strip casting, 406  
     Structural steel, carbon, 665, 667  
         chromium, 669  
         medium manganese, 668  
         mild-alloy, 665, 669  
         nickel, 668  
         riveting grade, 669.  
         silicon, 669  
         welding grade, 669  
     Submerged melt welding, 469  
     Substitute solders, 862  
     Substitutional solid solution, 268  
     Sulfur control, in blast furnace, 164; with calcium carbide in electric steelmaking, 211; with manganese in steelmaking, 205, 213, 219  
         copper, 839  
         prints, 218  
         segregation in steel, 218  
     *Sumet Bronze,* 823

- Super Cobalt steel*, 789
- Supercooling, 66
- Super Dreadnought High Speed steel*, 785
- Super-heat-resistant alloys, 651
- Super Invar*, 854
- Superior No. 1 steel*, 777
  - No. 3, 777
- Supernickel*, 581
- Super Nilvar*, 854
- Super Panther steel*, 785
- Super Steel*, 785
- Supervan Dreadnought High Speed steel*, 785
- Supremus steel*, 784
  - Extra steel, 785
- Surface hardening, 733
- Swaging, 428
- Swedish iron, 157
- Swindell-Dressler electric furnace, 115
- S-588 steel, 653
- S-590 steel, 653
- S-816 steel, 651
  
- Tailings, 107
- Tainton process for electrolytic deposition
  - of zinc, 152
- T-Alloy steel, 781
- Tap Die steel, 772
- Tapered hardenability test bar, 385, 386
- Tee-fittings for copper water tubing, 577
- Tellurium copper, 559, 839
  - lead, 654
- Temperature coefficient
  - of chemical reaction, 16
  - of corrosion, 489
  - of resistance, 46
  - of thermal expansion, 47
- Temperature, color scale of, 48
- Temper colors, 770-771
- Tempering, 388
- Tensile test, 29-35
  - impact, 27, 28
- Terminal solid solution (see primary solid solution)
- Terne plate, 503
- Testing, bearing metals, 803
  - creep, 35, 593-598
  - damping capacity, 43
  - ductility, 537
  - effect of speed of, 34
  - fatigue, 38-39
  - hardness, 20-25
  - Testing, impact, 27-29
    - nondestructive, for soundness, 50-54
    - radiographic, 50-52, 395
    - relaxation, 37
    - tensile, 29-35
    - time for rupture, 36
    - tool steels, 767-768
    - welds, 471
  - Thermal analysis, 65
    - conductivity, 45
    - expansion, 47
  - Thermalloy "50,"* 625
    - "72," 626
  - Thermit welding, 456
  - Thermocouples, 850
  - Thermoelectric materials, 850-852
  - Thermoid steel*, 783
  - Thickness of brazed joint vs. strength, 452
  - Three Star High Speed steel*, 789
  - Throwing power, 508
  - Time, effect in heat treatment, 338
    - quenching, 379
  - Time for rupture test, 36, 37
- Tin
  - blast-furnace smelting, 257
  - commercial grades, 260
  - electrolytic refining, 259
  - impurities in ores, 257
  - International Tin Cartel, 257
  - liquating, 258
  - ores, 257
  - pyrometallurgical refining, 258, 259
  - sweating, 258
  - reverberatory-furnace smelting, 258
- Tin alloys, 569
  - babbitts, 807
  - bearings, 807
  - lead babbitts, 825
  - pewters, 569
  - solders, 859
- Tinicosil*, 568
- Tin plate, 502
- Tin plating to prevent nitriding, 512, 741
- Tisco 109*, 625
- Titanium-bearing 18:8, 619
- Titus steel*, 775
- T-K steel, 781
- Tobin Bronze*, 581
- Tocco process, 732
- Toncan Iron*, 528
- Tool Room Oil Hardening steel*, 775
- Tool steel, 761-791
  - effect of alloying elements, 761

- Tool steel, heat-treatment, 763  
     cold-treatment, 764  
     metallography, 764-765  
     historical, 767  
     testing, 767-768  
     carbon, structural changes during  
         cooling, 315-317  
*Tophet A*, 844  
     *C*, 846  
*Top Notch* steel, 779  
     tops-and-bottoms process for nickel, 243,  
         244  
 Total life of resistance alloys, 842  
*Tough "H" Temper* steel, 775  
     "*M*" *Temper*, 775  
     "*S*" *Temper*, 775  
 Tough-pitch copper, 234, 241, 539, 833  
     metallographic structure, 241  
 Transformations in iron, 101  
 Transformer steel, 878, 879  
 Transverse fissures, in rail steels, 744  
     flexure test for cast iron, 172  
 Trimetal bearings, 805  
*Triple Die* steel, 777  
 Triplex bearings, 805  
 Triplexing, 181, 209  
 Troosite, 365, 366  
*Truform* steel, 776  
 Tube drawing, 438  
     extrusion, 411, 416, 437  
     rolling, 432  
 Tubing manufacture, 411, 416, 429-438  
     to resist water corrosion, 572-586  
*Tungo* steel, 779  
     tungsten-alloy chisel and punch steels,  
         779  
     tungsten-chromium die steels for hot-  
         work, 783  
     tungsten die steels for hot-work, 781  
     tungsten heating units, 846  
     tungsten, low-high-carbon tool steels, 771  
*Twin-Mo* steel, 787  
 Twinning, 80-86  
*Twinvan* steel, 785  
*Two Star High Speed* steel, 784  
*Type "A" Stainless* steel, 607  
     "*M*" *Stainless*, 608  
     "*T*" *Stainless*, 607  
 Ultimate strength, 33  
*Ultra Cobalt* steel, 789  
*Ultradie No. 1* steel, 777  
     *No. 2*, 777  
*Uniloy 4-6* steel, 603  
     1409, 607  
     1435, 607  
     1809, 608  
     18100-1860, 608  
     2009, 611  
     2825, 612  
 Unionmelt process, 469  
 United States production and consump-  
     tion of metals since 1925, 6  
 Universal rolling mill, 424  
*U.S.S. Copper Steel*, 528  
     4-6, 603  
     5, 603  
     12, 607  
     18.8, 616  
*Utica* steel, 773  
 Valve composition, 587  
*Vanite High Speed* steel, 785  
 Van't Hoff's law of mobile equilibrium,  
     122  
 Vapocarb process, 736  
*Vascoloy-Ramet* alloy, 791  
*V-Chrome* steel, 603  
*Vectolite 61*, 873  
*Venango* steel, 773  
 Vertical redistillation process for zinc, 149  
 Vertical-retort process for zinc, 147  
*Vibro* steel, 779  
*Vicalloy*, 875  
 Vickers hardness test, 22  
*Vinco* steel, 784  
*Vitallium*, 651  
 Vitreous enameling, 524  
*V.L.M.* steel, 786  
*V.M. Dreadnought High Speed* steel, 786  
 Volatilization processes for lead, 256  
*Vulcan Crucible* steel, 770  
     *Hardrite*, 773  
     *TM-5*, 786  
*Vul-Mo* steel, 786  
 Waelz process  
     for lead ores, 256  
     for zinc ores, 151  
*Wando* steel, 776  
 Washington steel, 769  
*Water Die* steel, 775  
 Water quenching, 378  
 Wear-resistant alloys, 731-759  
 Wedge roasting furnace, 230

- Welding, 429, 452-471  
     bronze, 870  
     grade of structural steel, 669  
     silicon bronze, 719  
     steel rails, thermit, 745  
     4-6% chromium steels, 601  
*Wemco* iron, 877  
*Westinghouse Alloy*, 883  
 White martensite, 364  
     cast iron, 170, 332; for malleabilizing,  
         369, 701; *Ni-Hard* type, 170; wear-  
         resistant, 750  
     metal bearings for heavy duty, 810-  
         818  
     metal bearings for light duty, 825  
     metal in copper converting, 234  
     slag, 211  
*Widia*, 791  
 Widmannstaetten structure, 585, 692  
 Wiedemann-Franz law, 45  
 Williams direct casting process, 404  
 Winged ingots, 215  
*Wings Coin Babbitt*, 828  
 Wiping solders, 859  
 Wire  
     bridge, 672  
     drawing, 439-441  
     extrusion, 411  
     solder, extrusion, 416  
*Wolfram* steel, 784  
*Wood's metal*, 864  
 Work-hardening, 17  
 Working, 418-440  
 World production of metals since 1925, 6  
 Wrought *Illium R*, 649  
 Wrought iron, 180-190, 574-575  
     bell welding of pipe, 429  
     chain, 454  
     forge welded, 454, 455  
     lap welding of pipe, 430  
 Wrought *Inconel*, 644  
 Wrought manganese bronze, 724  
 Wrought *Monel* metal, 638  
*Wyndalloy 720*, 729  
  
*X-B*, 625  
*X.L. Chisel* steel, 779  
 X-ray testing, 50-52  
  
 "Y" Alloy, 658  
 Yellow brass (2 and 1) pipe, 576  
     plug-type dezincification, 492  
 Yellow brass die castings, 568  
  
 Yield point, 32  
     point effect in mild steel, 534  
     strength, 31  
*Yoloy* steel, 670  
 Yonghans-Rossi direct casting process,  
     405  
  
*Zamak*, 561, 797  
*Zilloy*, 554  
 Zinc, 143  
     Belgian-type distillation furnace, 145  
     commercial specifications for, 153  
     continuous vertical-retort process,  
         147  
     distillation process, 144  
     high current-density deposition, 152  
     high grade, 153  
     horizontal retort process, 144  
     horizontal-retort redistillation, 147  
     low current density deposition, 152  
     ores, 143  
     prime western, 153  
     remelting of cathodes, 153  
     St. Joseph Lead Company's electro-  
         thermic process, 150  
     Tainton process, 152  
     vertical redistillation, 149  
     Waelz process, 151  
 Zinc alloys  
     bearings, 816-817  
     die castings, 560-563  
     rolled, 554  
     stamping dies, 795  
 Zinc bronze, 588  
 Zinc coatings  
     galvanized, 501  
     electrozinc, 507  
     Sherardized, 515  
*Z-Metal*, 702  
 "Z" Nickel, 636  
*ZN* steel, 775  
*Zorite*, 625  
*Zyglo*, 53, 54  
  
*1:1:1* tool steel, 779  
 1:2:1 rule, 290  
     application to simple binary dia-  
         grams, 291  
*139B* steel, 775  
 15:35 heat-resisting alloys, 625  
 17:7 stainless steel, 677-678  
 18:8 stainless steel, 538, 613, 665, 674-679  
 2 and 1 brass, 576

- .2B Hot Working Die steel*, 781
- 25:20 alloys heat-resisting alloys, 625
- 25-30% chromium irons, 611
- 2907, 652
- 29:9 heat-resisting alloys, 623
- 3C steel, 777
- 3124, 652
- 35:15 heat-resisting alloys, 625
  - electrical resistance vs. temperature 845
- 4-6% chromium steel, 599
  - castings, heat treatment, 601
- 446 alloy, 855
- 50:50 *Permendur*, 882
- 55 alloy, 855
- 66 *High Speed steel*, 787
- 67 steel, 773
- 610 *Air Hardening steel*, 777
- 6-6-2 steel, 787
- 72% Be-28% Al alloy, 665
- 812 *Die steel*, 777
- 85:5:5:5, 586
- 89 *MC steel*, 775
- 946 alloy, 839
- 96 *KC steel*, 775
- 999 *High Speed steel*, 790





